



US00D792609S

(12) **United States Design Patent** (10) **Patent No.:** **US D792,609 S**
Smith et al. (45) **Date of Patent:** **** Jul. 18, 2017**

(54) **CASING BEAD WITH METAL LATH ATTACHMENT FEATURE**

FOREIGN PATENT DOCUMENTS

(71) Applicant: **CLARKWESTERN DIETRICH BUILDING SYSTEMS LLC**, West Chester, OH (US)

BE 1019998 A3 3/2013
CA 93969 S 11/2001
(Continued)

(72) Inventors: **Jeremy Ryan Smith**, Carrollton, VA (US); **Nick Joseph Apanovich**, Tampa, FL (US); **Erenio Reyes**, Miami, FL (US); **Christopher K. Little**, Suwanee, GA (US)

OTHER PUBLICATIONS

““F” Beads,” Vinyl Corp., 2015, 1 pg. downloaded Jan. 28, 2016 from <http://www.vinylcorp.com/products/drywall-veneer/beads-trims/f-beads>.

(73) Assignee: **Clarkwestern Dietrich Building Systems LLC**, West Chester, OH (US)

Primary Examiner — Cynthia Ramirez
Assistant Examiner — Gino Colan

(**) Term: **15 Years**

(74) *Attorney, Agent, or Firm* — Frost Brown Todd LLC

(21) Appl. No.: **29/537,809**

(57) **CLAIM**

(22) Filed: **Aug. 28, 2015**

The ornamental design for a casing bead with metal lath attachment feature, as shown and described.

(51) **LOC (10) Cl.** **25-01**

(52) **U.S. Cl.**
USPC **D25/119**

DESCRIPTION

(58) **Field of Classification Search**
USPC D25/119–125, 69, 56, 48.8, 47, 49, 60, D25/141, 138, 58, 38.1, 135, 136, 35, 61; 52/179, 506.06, 506.07, 716.1, 579, 578, 52/506.05, 489.1, 309.14, 518, 555, 52/204.59, 204.5, 255, 254, 293.1, 202, 52/408, 302.6, 443, 831; 40/658, 666, 40/426, 549, 761
CPC ... E04F 13/06; E04F 13/068; E04F 2013/065; E04F 13/047
See application file for complete search history.

FIG. 1 is a front perspective view of a casing bead with metal lath attachment feature, showing our new design; FIG. 2 is a front elevational view thereof; FIG. 3 is a rear elevational view thereof; FIG. 4 is a left elevational view thereof; FIG. 5 is a right elevational view thereof; FIG. 6 is a top plan view thereof; and, FIG. 7 is a bottom plan view thereof.

The broken lines in FIGS. 1, 6, and 7 are included for purposes of illustrating portions of the casing bead with metal lath attachment feature that form no part of the claimed design. The casing bead with metal lath attachment feature is shown with a symbolic break in its length. The appearance of any portion of the casing bead with metal lath attachment feature between the break lines forms no part of the claimed design.

(56) **References Cited**

U.S. PATENT DOCUMENTS

2,679,156 A 5/1954 McFarland
3,412,512 A 11/1968 Hollister
3,754,367 A 8/1973 O’Konski et al.

(Continued)

1 Claim, 5 Drawing Sheets

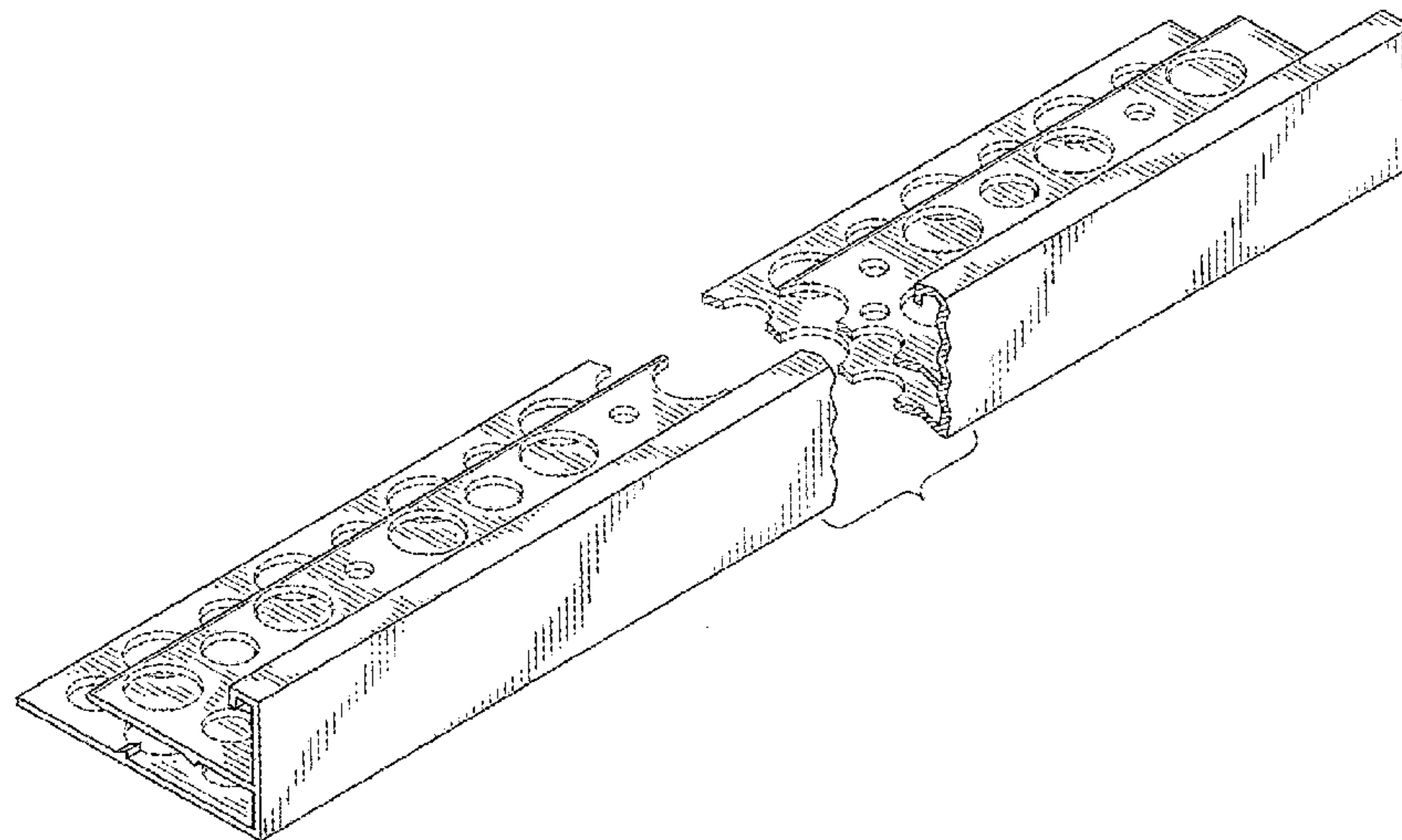

(56)

References Cited

U.S. PATENT DOCUMENTS

5,699,638	A	12/1997	Maylon	
5,946,870	A *	9/1999	Bifano	E04B 1/765 52/254
6,293,064	B1	9/2001	Larson	
6,298,609	B1 *	10/2001	Bifano	E04B 1/765 52/101
D459,007	S	6/2002	Campacci	
6,470,638	B1 *	10/2002	Larson	E04B 1/765 52/254
D471,991	S *	3/2003	Maylon	D25/119
6,609,341	B2	8/2003	Maylon et al.	
D503,227	S	3/2005	Rodolfo et al.	
D503,469	S	3/2005	Rodolfo et al.	
D656,603	S	3/2012	Egan et al.	
D703,306	S	4/2014	Little et al.	
D703,307	S	4/2014	Little et al.	
8,869,491	B2 *	10/2014	Little	E04F 13/06 52/255
8,875,468	B2	11/2014	Dhinjan	
8,910,437	B2	12/2014	Robertson	
9,303,413	B2	4/2016	Koenig, Jr. et al.	
D761,971	S *	7/2016	Apanovich	D25/119
D762,310	S *	7/2016	Apanovich	D25/119
D767,111	S *	9/2016	Glick, Jr.	D23/386
2012/0110936	A1	5/2012	Egan et al.	

FOREIGN PATENT DOCUMENTS

CA	107604	S	12/2005
CA	107605	S	12/2005
CA	107606	S	12/2005
CA	107607	S	12/2005
CA	2816036	A1	5/2012
CA	158042	S	6/2015
EP	0473393	A1	3/1992
WO	WO 2007/012897	A1	2/2007
WO	WO 2014/023620	A1	2/2014

OTHER PUBLICATIONS

““J” Beads,” Vinyl Corp., 2015, 1 pg. downloaded Jan. 28, 2016 from <http://www.vinylcorp.com/products/drywall-veneer/beads-trims/j-beads>.

““L” Beads (L-Bead Perforated),” Vinyl Corp., 2015, 1 pg. downloaded Jan. 28, 2016 from <http://www.vinylcorp.com/products/drywall-veneer/beads-trims/l-beads-l-bead-perforated>.

“#66N Short Flange Casing Bead”, ClarkDietrich, 2015, 1 pg., downloaded Nov. 16, 2015 from <http://www.clark.com/products/metal-corner-casing-beads/66n-short-flange-casing-bead>.

“#Zinc Short Flange Casing Bead”, ClarkDietrich, 2015, 1 pg., downloaded Nov. 16, 2015 from <http://www.clarkdietrich.com/products/zinc-corner-casing-beads/66n-zinc-short-flange-casing-bead>.

“#66X Expanded Flange Casing Bead”, ClarkDietrich, 2015, 1 pg., downloaded Nov. 16, 2015 from <http://www.clarkdietrich.com/products/metal-corner-casing-beads/66x-expanded-flange-casing-bead>.

“#66X Zinc Expanded Flange Casing Bead”, ClarkDietrich, 2015, 1 pg., downloaded Nov. 16, 2015 from <http://www.clarkdietrich.com/products/zinc-corner-casing-beads/66x-zinc-expanded-flange-casing-bead>.

“#701A/#801A Zinc J-Trim,” ClarkDietrich, 2015, 1 pg., downloaded Jan. 28, 2016 from <http://www.clarkdietrich.com/products/zinc-veneer-plaster-beads-trims/701a-801a-zinc-j-trim>.

“#701A/#801A J-Trim,” ClarkDietrich, 2015, 1 pg., downloaded Feb. 16, 2016 from <http://www.clarkdietrich.com/products/metal-veneer-plaster-beads-trims/701a-801a-j-trim>.

“#701B/#801B L-Trim,” ClarkDietrich, 2015, 1 pg., downloaded Feb. 16, 2016 from <http://www.clarkdietrich.com/products/metal-veneer-plaster-beads-trims/701b-801b-l-trim>.

“#701B/#801B Zinc L-Trim,” ClarkDietrich, 2015, 1 pg. downloaded Jan. 28, 2016 from <http://www.clarkdietrich.com/products/zinc-veneer-plaster-beads-trims/701b-801b-zinc-l-trim>.

“2” J-Weep Low Back ,” ClarkDietrich, 2015, 1 pg. downloaded Jan. 28, 2016 from <http://www.clarkdietrich.com/products/metal-weep-sill-screeds/2-j-weep-low-back>.

“3½” J-Weep High Back ,” ClarkDietrich, 2015, 1 pg. downloaded Jan. 28, 2016 from <http://www.clarkdietrich.com/products/metal-weep-sill-screeds/3-1-2-j-weep-high-back>.

“Adjustable Corner Trim,” Vinyl Corp., 2015, 1 pg. downloaded Jan. 28, 2016 from <http://www.vinylcorp.com/products/drywall-veneer/beads-trims/adjustable-corner-trim>.

“Angled Casing Beads”, Vinyl Corp., 2015, 1 pg., downloaded Nov. 16, 2015 from <http://www.vinylcorp.com/products/stucco-plaster/casing-beads/angled-casing-beads>.

“Archmaker™ Casing Beads”, Vinyl Corp., 2015, 1 pg., downloaded Nov. 16, 2015 from <http://www.vinylcorp.com/products/stucco-plaster-casing-beads/archmaker-casing-beads>.

“Archmaker™ /Bandmaker™ Casing Beads”, Vinyl Corp., 2015, 1 pg., downloaded Nov. 16, 2015 from <http://www.vinylcorp.com/products/stucco-plaster/casing-beads/archmaker-bandmaker-casing-beads>.

“Bandmaker Series Casing Beads”, Vinyl Corp., 2015, 1 pg. downloaded Nov. 16, 2015 from <http://www.vinylcorp.com/products/stucco-plaster/casing-beads/bandmaker-series-casing-beads>.

“BM 66 Series 1-Piece Bandmaker”, Vinyl Corp., 2015, 1 pg., downloaded Nov. 16, 2015 from <http://www.vinylcorp.com/products/stucco-plaster/casing-beads/bm-66-series-1-piece-bandmaker>.

“Bullnose Casing Beads”, Vinyl Corp., 2015, 1 pg., downloaded Nov. 16, 2015 from <http://www.vinylcorp.com/products/stucco-plaster/casing-beads/bullnose-casing-beads>.

“Casing Beads (with Weep Holes for ½” Sheathing)”, Vinyl Corp., 2015, 1 pg., downloaded Nov. 16, 2015 from <http://www.vinylcorp.com/products/stucco-plaster/casing-beads/casing-beads-weep-holes-12-sheathing>.

“Casing Beads / Plaster Stops”, Vinyl Corp., 2015, 1 pg., downloaded Nov. 16, 2015 from <http://www.vinylcorp.com/products/stucco-plaster/casing-beads-plaster-stops>.

“Casing Beads with Reveal”, Vinyl Corp., 2015, 1 pg., downloaded Nov. 16, 2015 from <http://www.vinylcorp.com/products/stucco-plaster/casing-beads/casing-beads-reveal>.

“Casing Beads with Weep Holes”, Vinyl Corp., 2015, 1 pg., downloaded Nov. 16, 2015 from <http://www.vinylcorp.com/products/stucco-plaster/casing-beads-casing-beads-weep-holes>.

“Ceiling Trim Surface Mount (L-Bead Perforated),” Vinyl Corp., 2015, 1 pg. downloaded Jan. 28, 2016 from <http://www.vinylcorp.com/products/drywall-veneer/beads-trims/ceiling-trim-surface-mount-l-bead-perforated>.

“Ceiling Trims (L-Bead Perforated),” Vinyl Corp., 2015, 1 pg. downloaded Jan. 28, 2016 from <http://www.vinylcorp.com/products/drywall-veneer/beads-trims/ceiling-trims-l-bead-perforated>.

“D-66 Drop Plaster Stop”, Vinyl Corp., 2015, 1 pg., downloaded Nov. 16, 2015 from <http://www.vinylcorp.com/products/stucco-plaster/casing/beads/d-66-drop-plaster-stop>.

“DEFS 45 Degree L-Bead,” Vinyl Corp., 2015, 1 pg. downloaded Jan. 28, 2016 from <http://www.vinylcorp.com/products/eifs-defs/defs-1-beads/defs-45-degree-1-bead>.

“DEFS Casing Beads (w-Drip),” Vinyl Corp., 2015, 1 pg. downloaded Jan. 28, 2016 from <http://www.vinylcorp.com/products/eifs-defs/defs-casing-beads/defs-casing-beads-w-drip>.

“DEFS Casing Beads (w-Weep),” Vinyl Corp., 2015, 1 pg. downloaded Jan. 28, 2016 from <http://www.vinylcorp.com/products/eifs-defs/defs-casing-beads/defs-casing-beads-w-weep>.

“DEFS Casing Beads,” Vinyl Corp., 2015, 1 pg. downloaded Jan. 28, 2016 from <http://www.vinylcorp.com/products/eifs-defs/defs-casing-beads/defs-casing-beads>.

“DEFS L Stop Casing Beads (w-Splice),” Vinyl Corp., 2015, 1 pg. downloaded Jan. 28, 2016 from <http://www.vinylcorp.com/products/eifs-defs/defs-l-beads/defs-l-stop-casing-beads-w-splice>.

“DEFS L Stop Casing Beads,” Vinyl Corp., 2015, 1 pg. downloaded Jan. 28, 2016 from <http://www.vinylcorp.com/products/eifs-defs/defs-l-beads/defs-l-stop-casing-beads>.

(56)

References Cited

OTHER PUBLICATIONS

“DEFS Weeped Starter Strip/Casing Beads (w-Drip),” Vinyl Corp., 2015, 1 pg., downloaded Feb. 16, 2016 from <http://www.vinylcorp.com/products/eifs-defs/defs-starter-strip/defs-weeped-starter-strip-casing-beads>.

“Double Ground (Bandmaker™ Series),” Vinyl Corp., 2015, 1 pg., downloaded Nov. 16, 2015 from <http://www.vinylcorp.com/products/stucco-plaster/casing-beads/double-ground-bandmaker-series>.

“Drip Casing Bead,” Vinyl Corp., 2015, 1 pg. downloaded Jan. 28, 2016 from <http://www.vinylcorp.com/products/eifs-defs/eifs-casing-beads/drip-casing-bead>.

“Female Casing Expansion Joint,” ClarkDietrich, 2015, 1 pg. downloaded Jan. 28, 2016 from <http://www.clarkdietrich.com/products/vinyl-expansion-control-joints/female-casing-expansion-joint>.

“Long Flange Casing Beads/Plaster Stops,” Vinyl Corp., 2015, 1 pg., downloaded Nov. 16, 2015 from <http://www.vinylcorp.com/products/stucco-plaster/casing-beads/long-flange-casing-beads-plaster-stops>.

“Muddable “J” Beads (with removable leg),” Vinyl Corp., 2015, 1 pg. downloaded Jan. 28, 2016 from <http://www.vinylcorp.com/products/drywall-veneer/beads-trims/muddable-j-beads-removable-leg>.

“Muddable “J” Beads,” Vinyl Corp., 2015, 1 pg. downloaded Jan. 28, 2016 from <http://www.vinylcorp.com/products/drywall-veneer/beads-trims/muddable-j-beads>.

“Muddable “J” Beads,” Vinyl Corp., 2015, 1 pg. downloaded Jan. 28, 2016 from <http://www.vinylcorp.com/products/eifs-defs/defs-j-beads/muddable-j-beads>.

“PB Header Weeped Starter Strip,” Vinyl Corp., 2015, 1 pg., downloaded Feb. 16, 2016 from <http://www.vinylcorp.com/products/eifs-defs/eifs-starter-strips/pb-header-weeped-starter-strip>.

“PB Standard Starter Strip/Casing Beads (3/32" Finish),” Vinyl Corp., 2015, 1 pg., downloaded Feb. 16, 2016 from <http://vinylcorp.com/products/eifs-defs/eifs-starter-strips/pb-standard-starter-strip-casing-beads-332-finish>.

“PB Starter Strip (Back Weep Holes 3/32" Finish),” Vinyl Corp., 2015, 1 pg., downloaded Feb. 16, 2016 from <http://vinylcorp.com/products/eifs-defs/eifs-starter-strips/pb-starter-strip-back-weep-332-finish>.

“PB Starter Strip (Front & Back Weep Holes 3/32" Finish),” Vinyl Corp., 2015, 1 pg., downloaded Feb. 16, 2016 from <http://vinylcorp.com/products/eifs-defs/eifs-starter-strips/pb-starter-strip-front-back-weep-332-finish>.

“PB Starter Strip (Front Weep Holes 3/32" Finish),” Vinyl Corp., 2015, 1 pg., downloaded Feb. 16, 2016 from <http://vinylcorp.com/products/eifs-defs/eifs-starter-strips/pb-starter-strip-front-weep-332-finish>.

“PB Starter Strip/Casing Beads (1/16" Finish),” Vinyl Corp., 2015, 1 pg., downloaded Feb. 16, 2016 from <http://vinylcorp.com/products/eifs-defs/eifs-starter-strips/pb-starter-strip-casing-beads-116-finish>.

“PB Starter Strip/Casing Beads (w-Drip & Weep 1/16" Finish),” Vinyl Corp., 2015, 1 pg., downloaded Feb. 16, 2016 from <http://vinylcorp.com/products/eifs-defs/eifs-starter-strips/pb-starter-strip-casing-beads-w-drip-weep-116-finish>.

“PB Starter Strip/Casing Beads (w-Drip 1/16" Finish),” Vinyl Corp., 2015, 1 pg., downloaded Feb. 16, 2016 from <http://vinylcorp.com/products/eifs-defs/eifs-starter-strips/pb-starter-strip-casing-beads-w-drip-116-finish>.

“PM Casing Bead,” Vinyl Corp., 2015, 1 pg. downloaded Jan. 28, 2016 from <http://www.vinylcorp.com/products/eifs-defs/eifs-casing-beads/pm-casing-beads>.

“PM Starter Strip (Reinforced),” Vinyl Corp., 2015, 1 pg., downloaded Feb. 16, 2016 from <http://vinylcorp.com/products/eifs-defs/eifs-starter-strips/pm-starter-strip-reinforced>.

“PM Starter Strip/Casing Beads (w-Front Weep Holes),” Vinyl Corp., 2015, 1 pg., downloaded Feb. 16, 2016 from <http://www.vinylcorp.com/products/eifs-defs/eifs-starter-strips/pm-starter-strip-casing-bead-w-front-weep-holes>.

“PM Starter Strip/Casing Beads,” Vinyl Corp., 2015, 1 pg., downloaded Feb. 16, 2016 from <http://vinylcorp.com/products/eifs-defs/eifs-starter-strips/pm-starter-strip-casing-bead>.

“Step Bead,” Vinyl Corp., 2015, 2 pgs., downloaded Nov. 16, 2015 from <http://www.vinylcorp.com/products/stucco-plaster/casing-beads/step-bead>.

“Vinyl Casing Bead/Plaster Stop,” ClarkDietrich, 2015, 1 pg., downloaded Nov. 16, 2015 from <http://www.clarkdietrich.com/products/vinyl-corner-casing-beads/vinyl-casing-bead-plaster-stop>.

“XL Long Flange Casing Beads/Plaster Stops,” Vinyl Corp., 2015, 1 pg., downloaded Nov. 16, 2015 from <http://www.vinylcorp.com/products/stucco-plaster/casing-beads/xl-long-flange-casing-beads-plaster-stops>.

Design U.S. Appl. No. 29/537,816, filed Aug. 28, 2015.

US Office Action, Non-Final, dated Nov. 29, 2016 for U.S. Appl. No. 29/537,816, 19 pgs.

“BackerBead™,” Vinyl Corp., 2015, 1 pg., downloaded Dec. 6, 2016 from <http://www.vinylcorp.com/products/stucco-plaster/casing-beads/backerbead%E2%84%A2>.

* cited by examiner

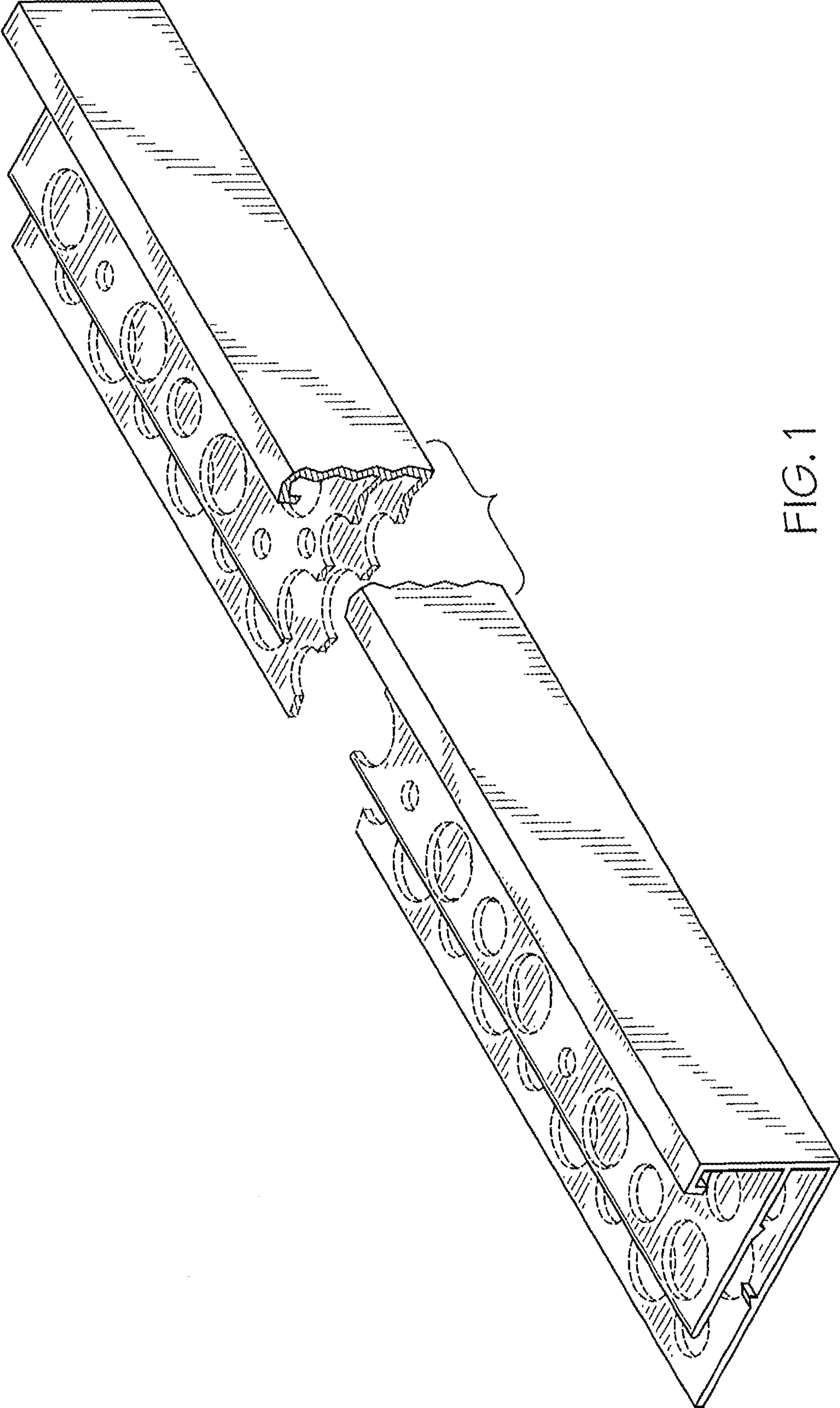

FIG. 1

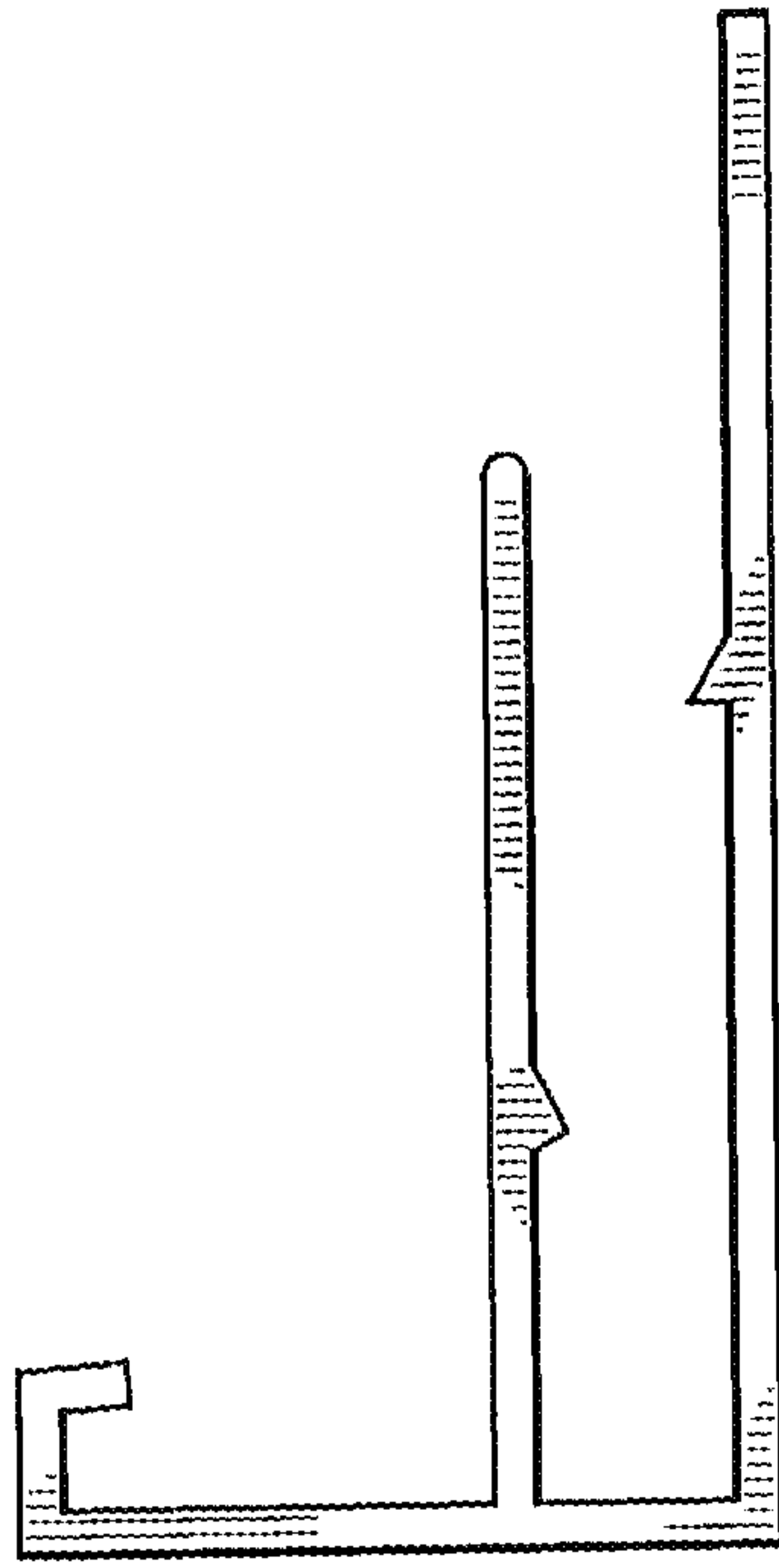

FIG. 3

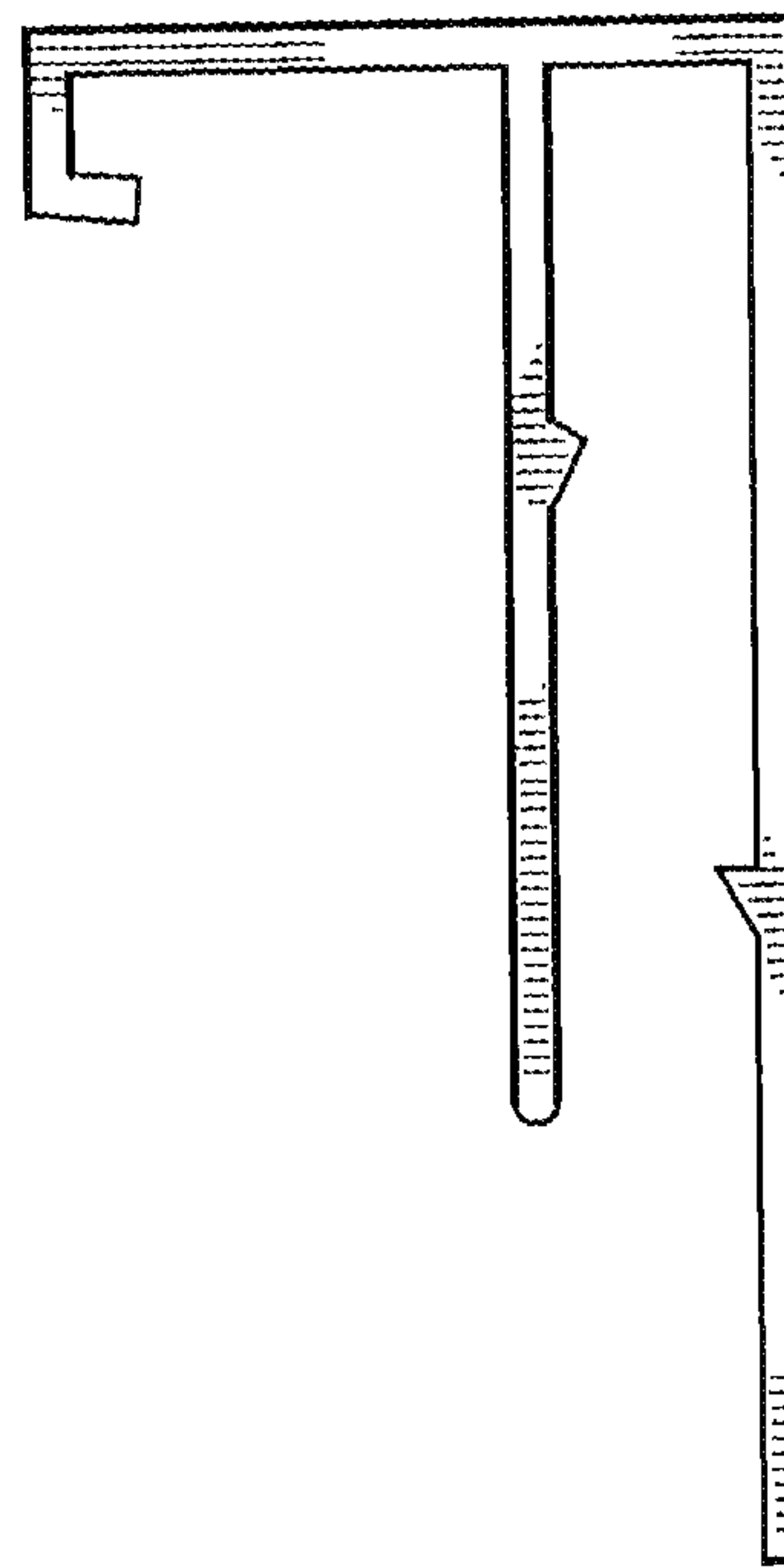

FIG. 2

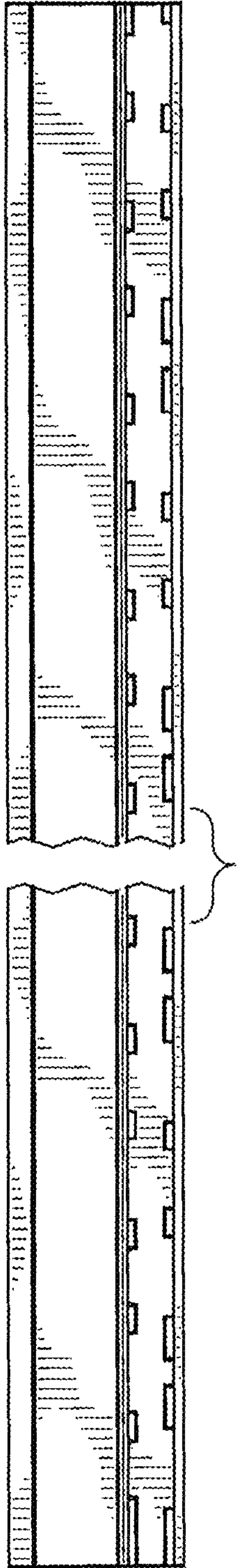

FIG. 4

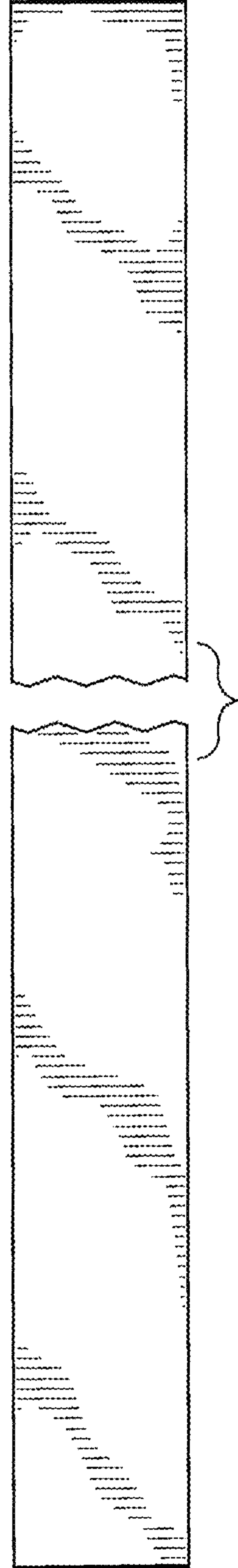

FIG. 5

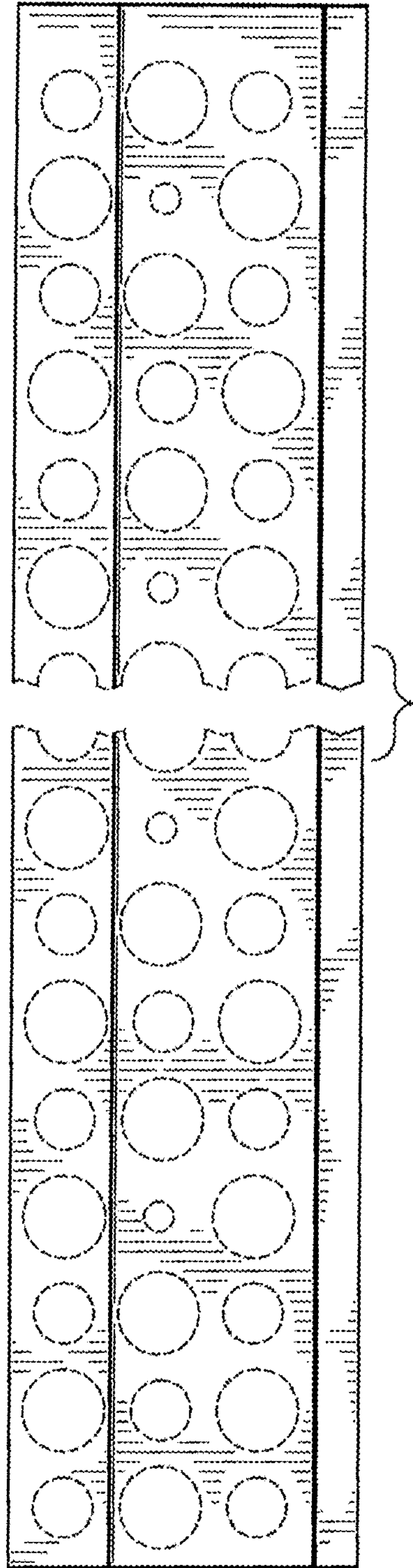

FIG. 6

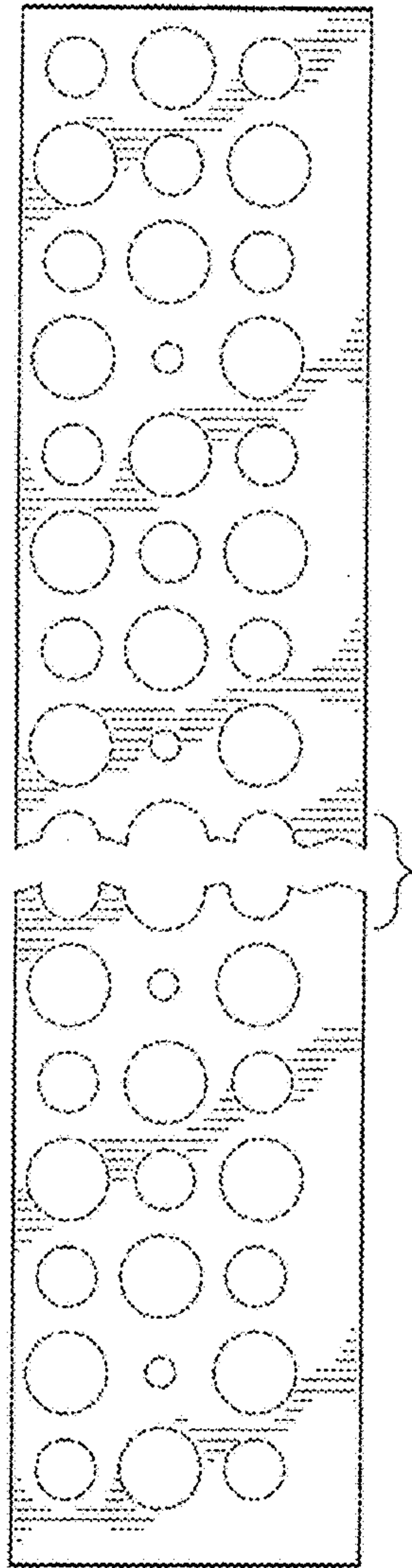

FIG. 7

UNITED STATES PATENT AND TRADEMARK OFFICE
CERTIFICATE OF CORRECTION

PATENT NO. : D792,609 S
APPLICATION NO. : 29/537809
DATED : July 18, 2017
INVENTOR(S) : Jeremy Ryan Smith et al.

Page 1 of 1

It is certified that error appears in the above-identified patent and that said Letters Patent is hereby corrected as shown below:

On the Title Page

DESCRIPTION, Lines 12-13, read “The casing bead with metal lath attachment feature is shown...”; which should be deleted and replaced with “The casing bead with metal lath attachment feature is shown....”

DESCRIPTION, Lines 13-15, read “The appearance of any portion of the casing bead with metal lath attachment feature...”; which should be deleted and replaced with “The appearance of any portion of the casing bead with metal lath attachment feature...”

Signed and Sealed this
Fifth Day of December, 2017



Joseph Matal

*Performing the Functions and Duties of the
Under Secretary of Commerce for Intellectual Property and
Director of the United States Patent and Trademark Office*