



US00D791680S

(12) **United States Design Patent** (10) **Patent No.:** **US D791,680 S**
Chin (45) **Date of Patent:** **** Jul. 11, 2017**

(54) **MOTORCYCLE BAG**

(71) Applicant: **Debra Chin**, Los Gatos, CA (US)

(72) Inventor: **Debra Chin**, Los Gatos, CA (US)

(**) Term: **15 Years**

(21) Appl. No.: **29/532,902**

(22) Filed: **Jul. 10, 2015**

(51) **LOC (10) Cl.** **12-16**

(52) **U.S. Cl.**
USPC **D12/409; D3/231**

(58) **Field of Classification Search**
USPC D12/409, 407, 114; D3/231, 232, 233,
D3/242, 214, 216, 226, 321, 324, 258
CPC A45C 15/00; A45C 13/02; A45C 9/00;
A45C 3/00
See application file for complete search history.

(56) **References Cited**

U.S. PATENT DOCUMENTS

D268,713 S *	4/1983	Pelavin	D3/287
D281,645 S *	12/1985	Bomes	D3/287
D288,146 S *	2/1987	Cathcart	D3/299
D326,772 S *	6/1992	Kennedy	D3/233
D344,184 S *	2/1994	Barker	224/42.11
D346,489 S *	5/1994	Bean	D12/407
D348,041 S *	6/1994	Lovett	D12/409
D360,182 S *	7/1995	Lovett	D12/409
D390,352 S *	2/1998	Lane	D3/216
D419,763 S *	2/2000	Wiebe	D3/232
6,298,993 B1 *	10/2001	Kalozdi	A45C 3/00 150/106
D479,648 S *	9/2003	De Lathouwer	D3/216
D530,081 S *	10/2006	Moon	D3/232
D674,183 S *	1/2013	Iacchetti	D3/216
D685,180 S *	7/2013	Baekgaard	D3/232
D706,535 S *	6/2014	Noer	D3/231
D712,652 S *	9/2014	Gonzales	D3/232
D714,544 S *	10/2014	Matheson	D3/232
D715,046 S *	10/2014	Stewart	D3/232
D725,900 S *	4/2015	McCue	D3/232

(Continued)

Primary Examiner — George D. Kirschbaum

Assistant Examiner — Clese Moore, Jr.

(74) *Attorney, Agent, or Firm* — Eric Karich; Karich & Associates

(57) **CLAIM**

The ornamental design for a “motorcycle bag,” as shown and described.

DESCRIPTION

FIG. 1 is a perspective view of a motorcycle bag, showing my new design;
 FIG. 2 is a front elevational view thereof;
 FIG. 3 is a rear elevational view thereof;
 FIG. 4 is a left side elevational view thereof
 FIG. 5 is a right side elevational view thereof;
 FIG. 6 is a top plan view thereof; and
 FIG. 7 is a bottom plan view thereof.
 FIG. 8 is a perspective view of the motorcycle bag illustrated in FIG. 1, with its tote handles extending from the top of the motorcycle bag;
 FIG. 9 is a front elevational view thereof;
 FIG. 10 is a rear elevational view thereof;
 FIG. 11 is a left side elevational view thereof
 FIG. 12 is a right side elevational view thereof;
 FIG. 13 is a top plan view thereof; and
 FIG. 14 is a bottom plan view thereof.
 FIG. 15 is a perspective view of the motorcycle bag illustrated in FIG. 1, with its backpack straps extending from the rear of the motorcycle bag;
 FIG. 16 is a front elevational view thereof;
 FIG. 17 is a rear elevational view thereof;
 FIG. 18 is a left side elevational view thereof
 FIG. 19 is a right side elevational view thereof;
 FIG. 20 is a top plan view thereof; and,
 FIG. 21 is a bottom plan view thereof.

1 Claim, 13 Drawing Sheets

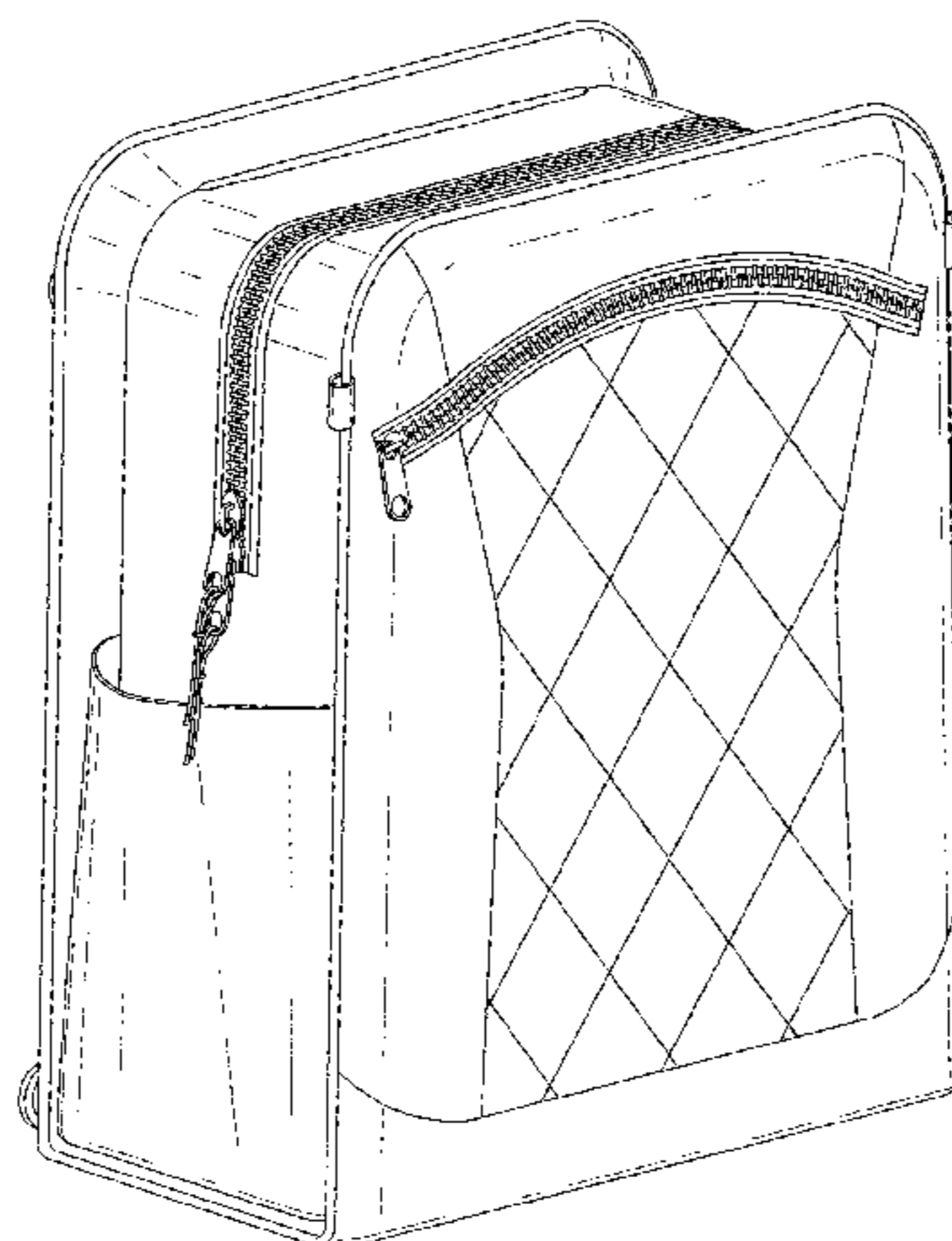

(56)

References Cited

U.S. PATENT DOCUMENTS

D727,617	S	*	4/2015	Chehebar	D3/233
D758,717	S	*	6/2016	Joo	D3/232
D767,880	S	*	10/2016	Fricano	D3/232
D770,764	S	*	11/2016	de Campos	D3/232
D776,921	S	*	1/2017	Bennetts	D3/232
2003/0201292	A1	*	10/2003	Lovett	A45C 15/00 224/585
2004/0011840	A1	*	1/2004	Lovett	A45C 13/30 224/584
2005/0194413	A1	*	9/2005	Baker	A45C 3/14 224/153
2006/0076392	A1	*	4/2006	Wilson	A45C 13/02 229/67.1

* cited by examiner

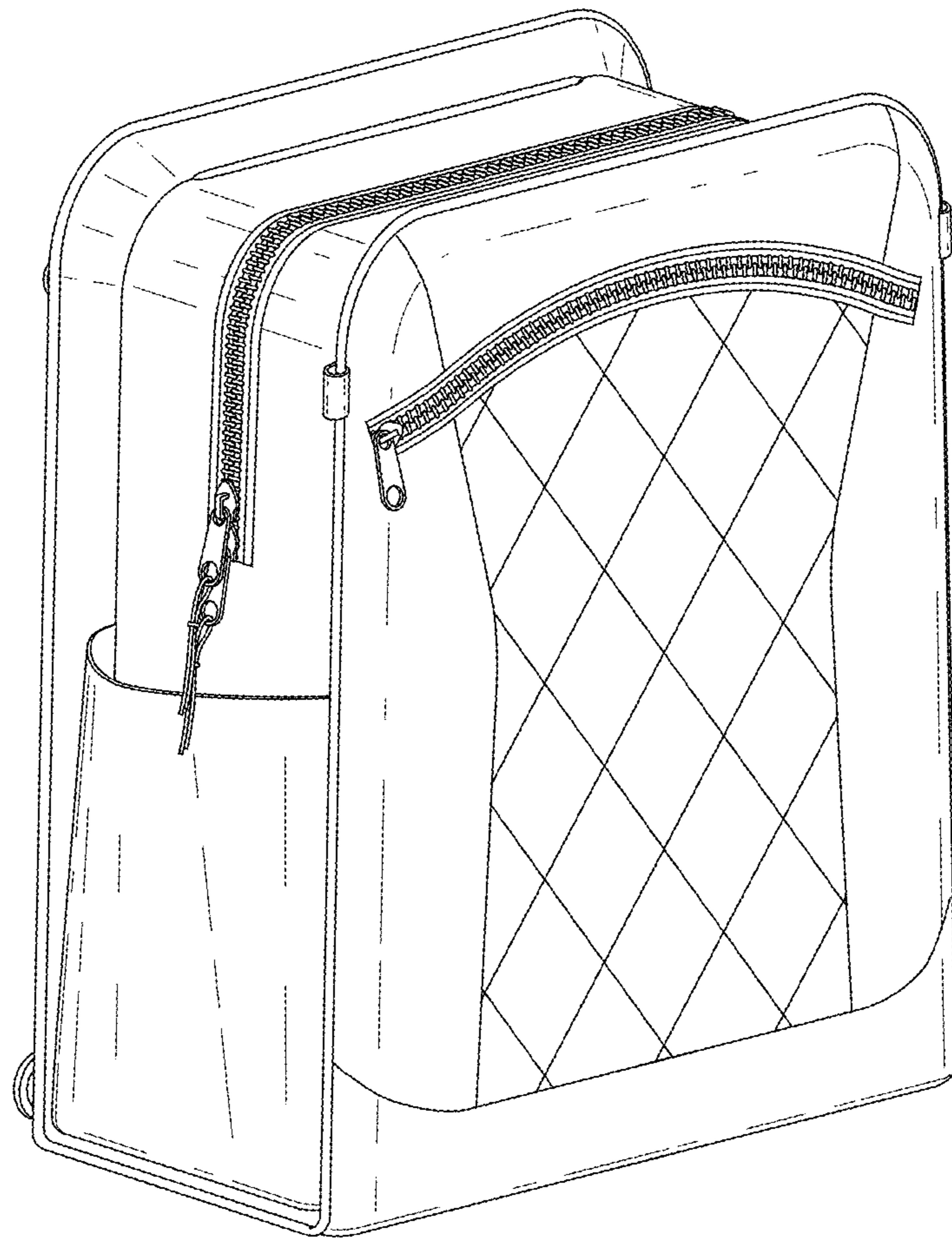

Fig. 1

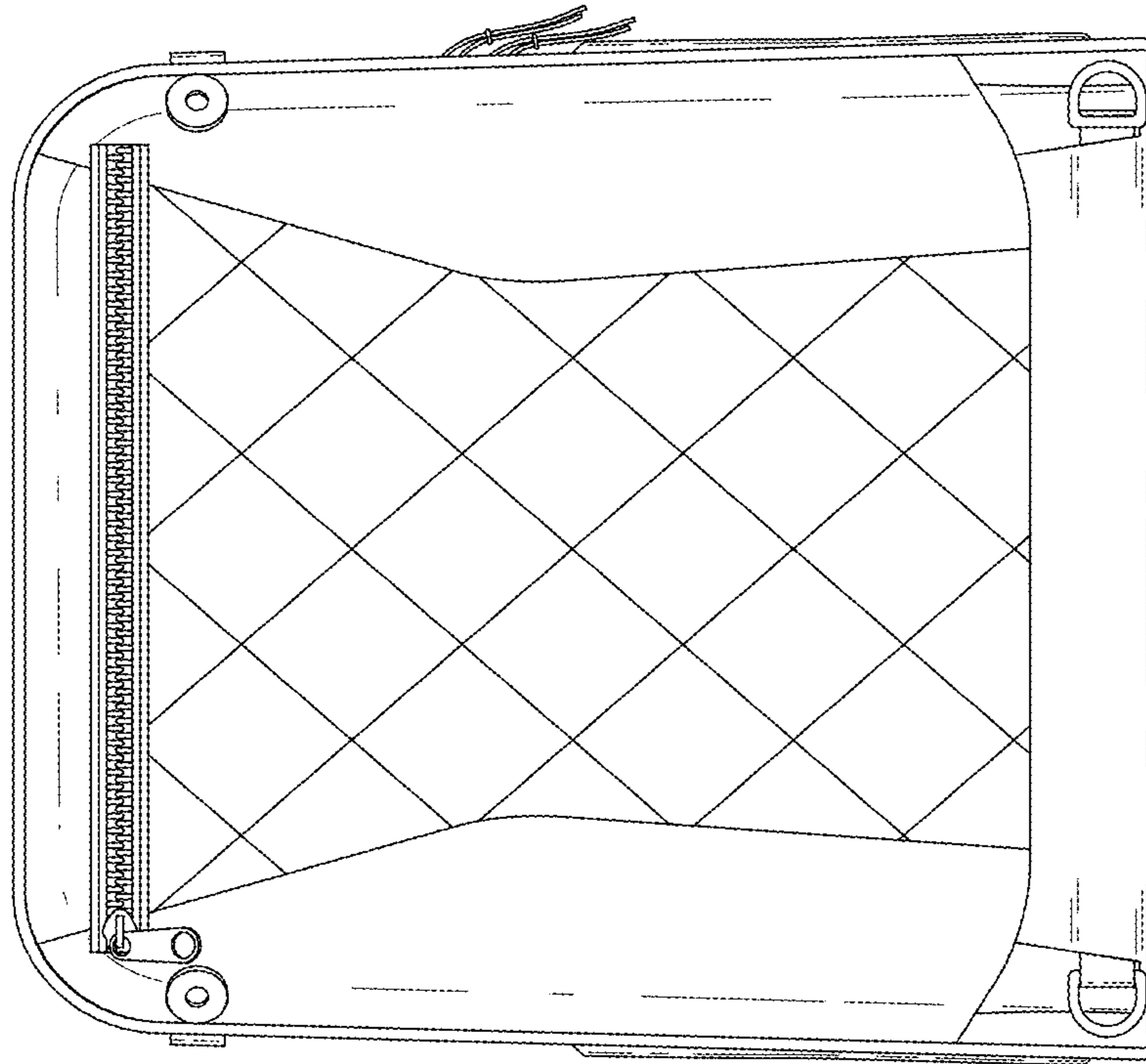

Fig. 2

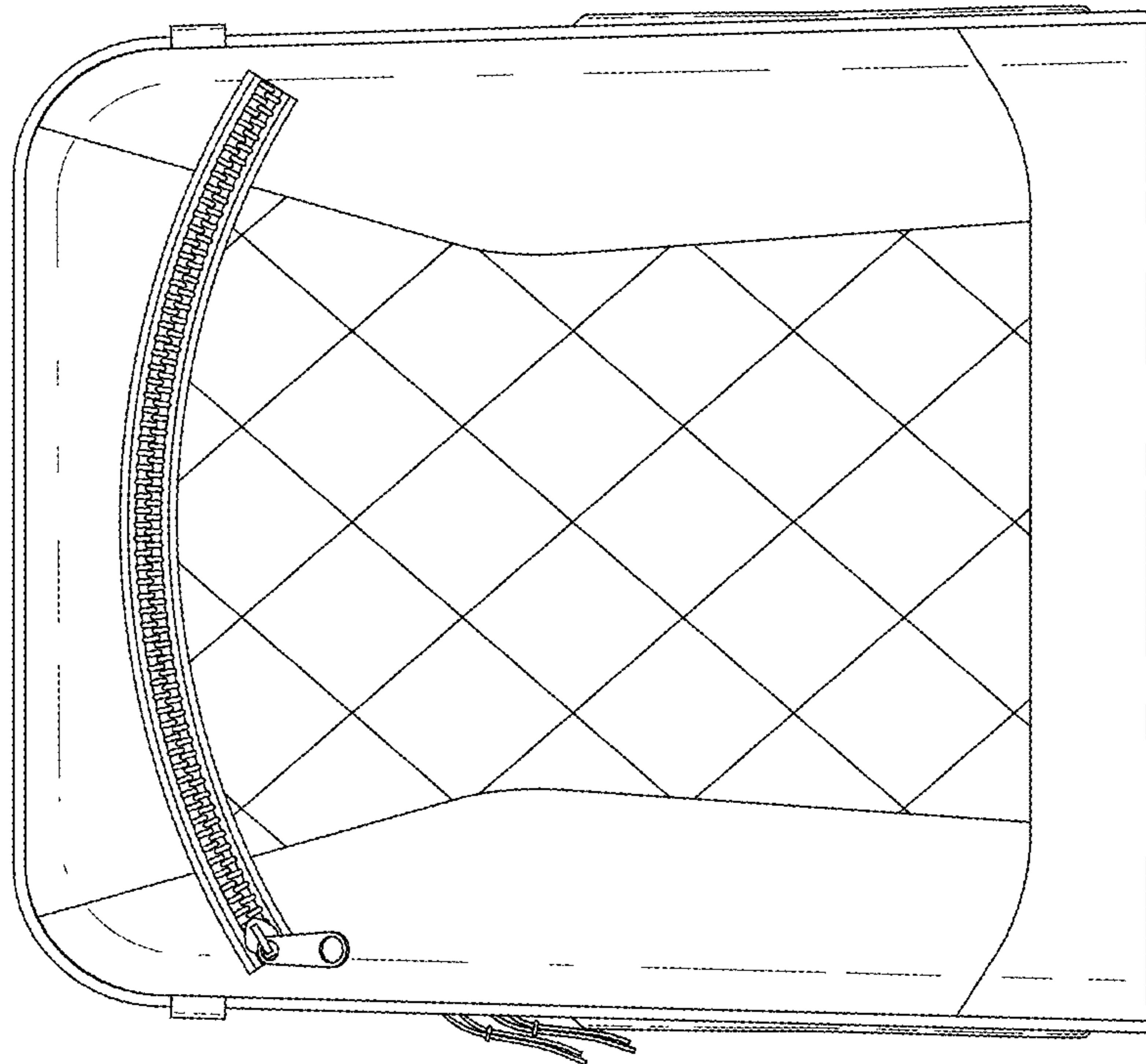

Fig. 3

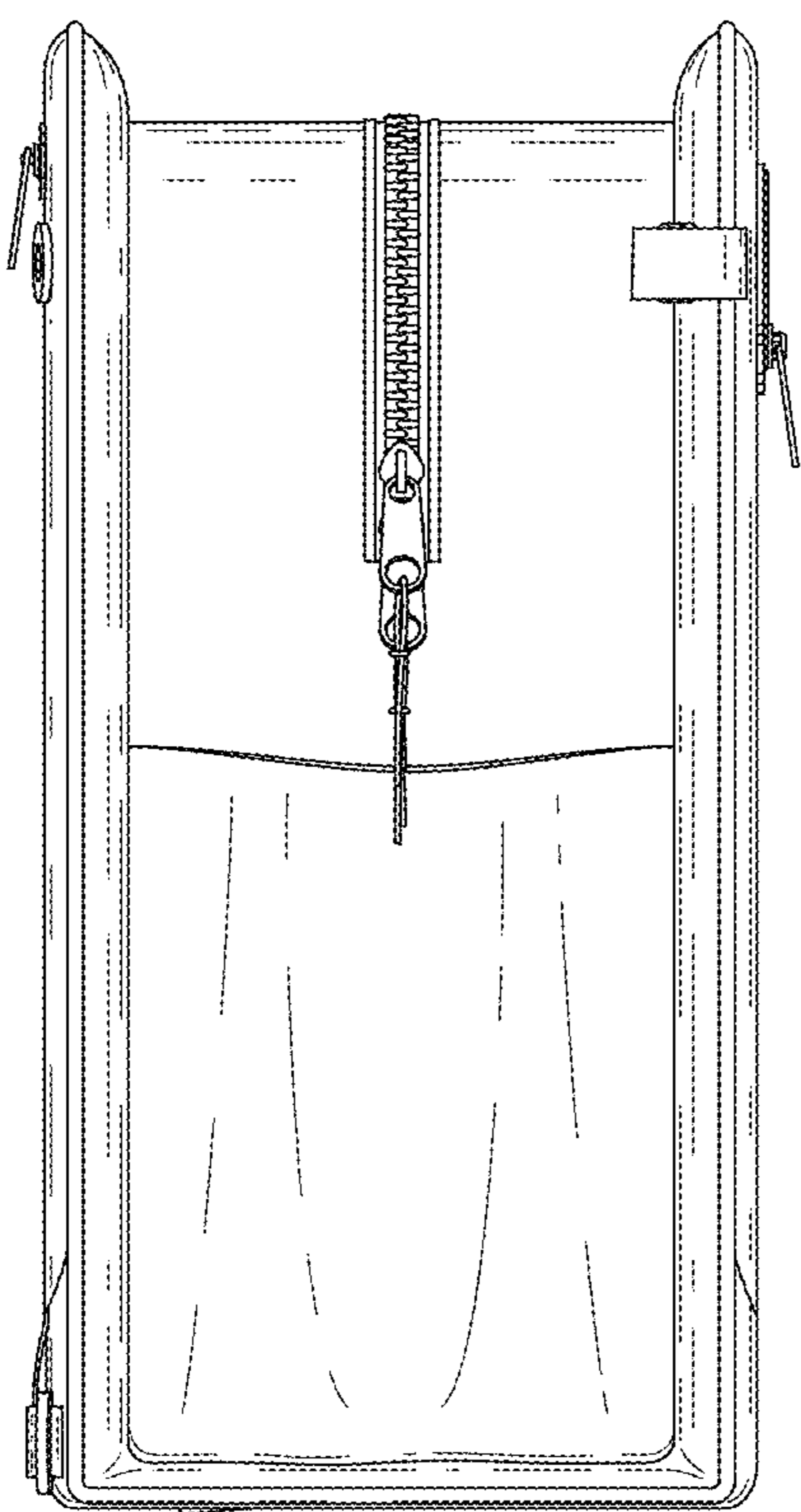

Fig. 4

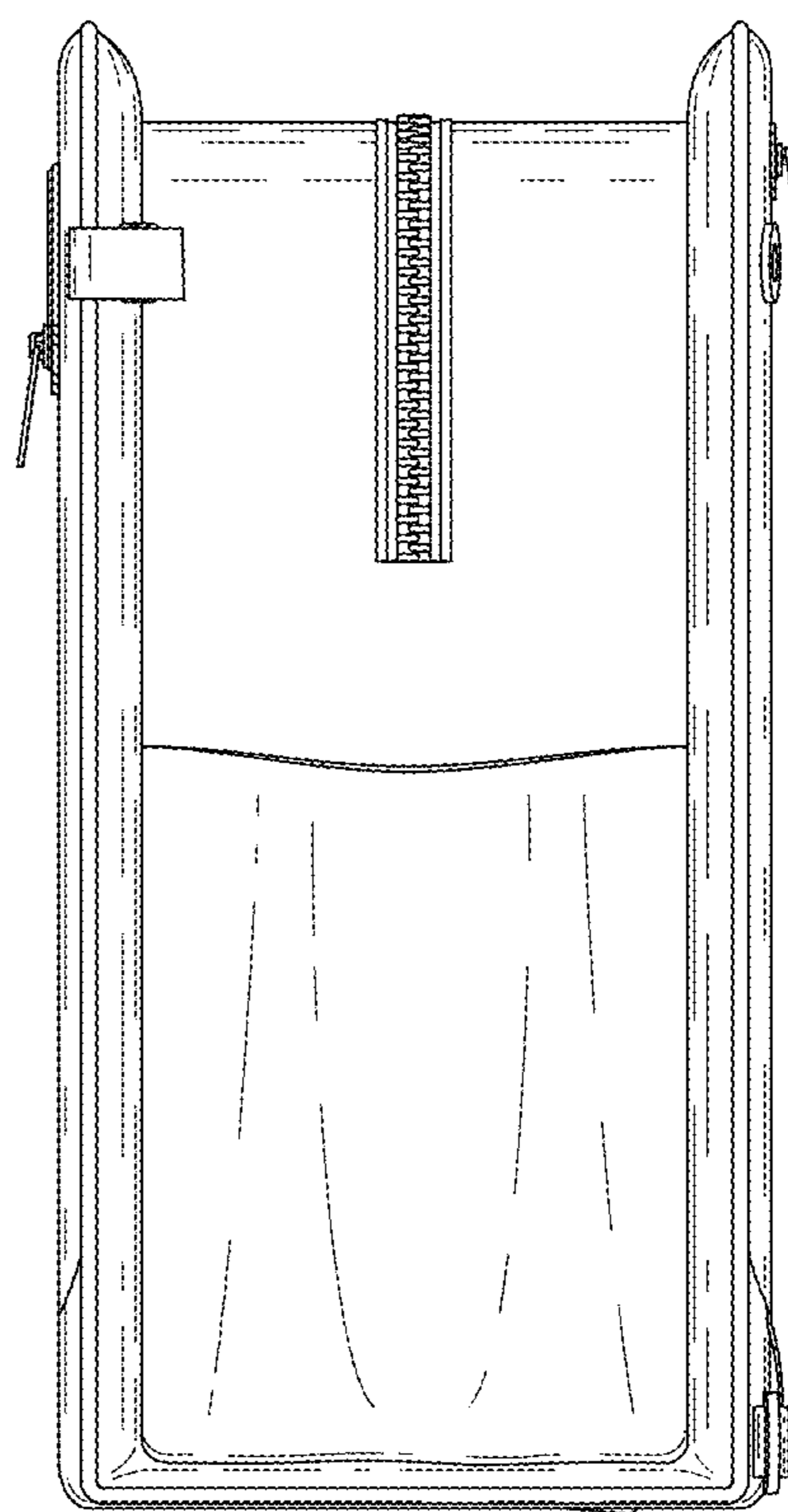

Fig. 5

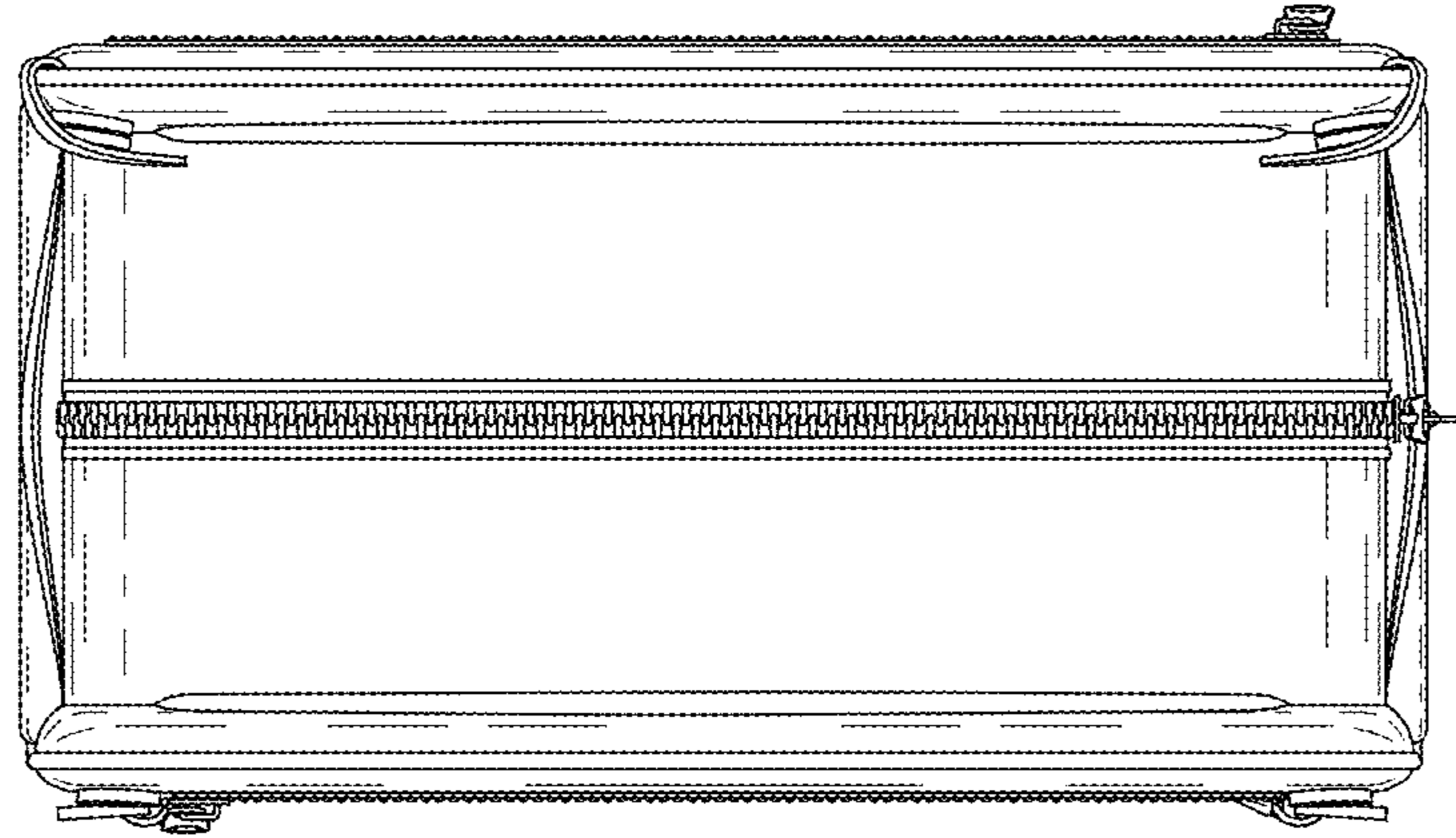

Fig. 6

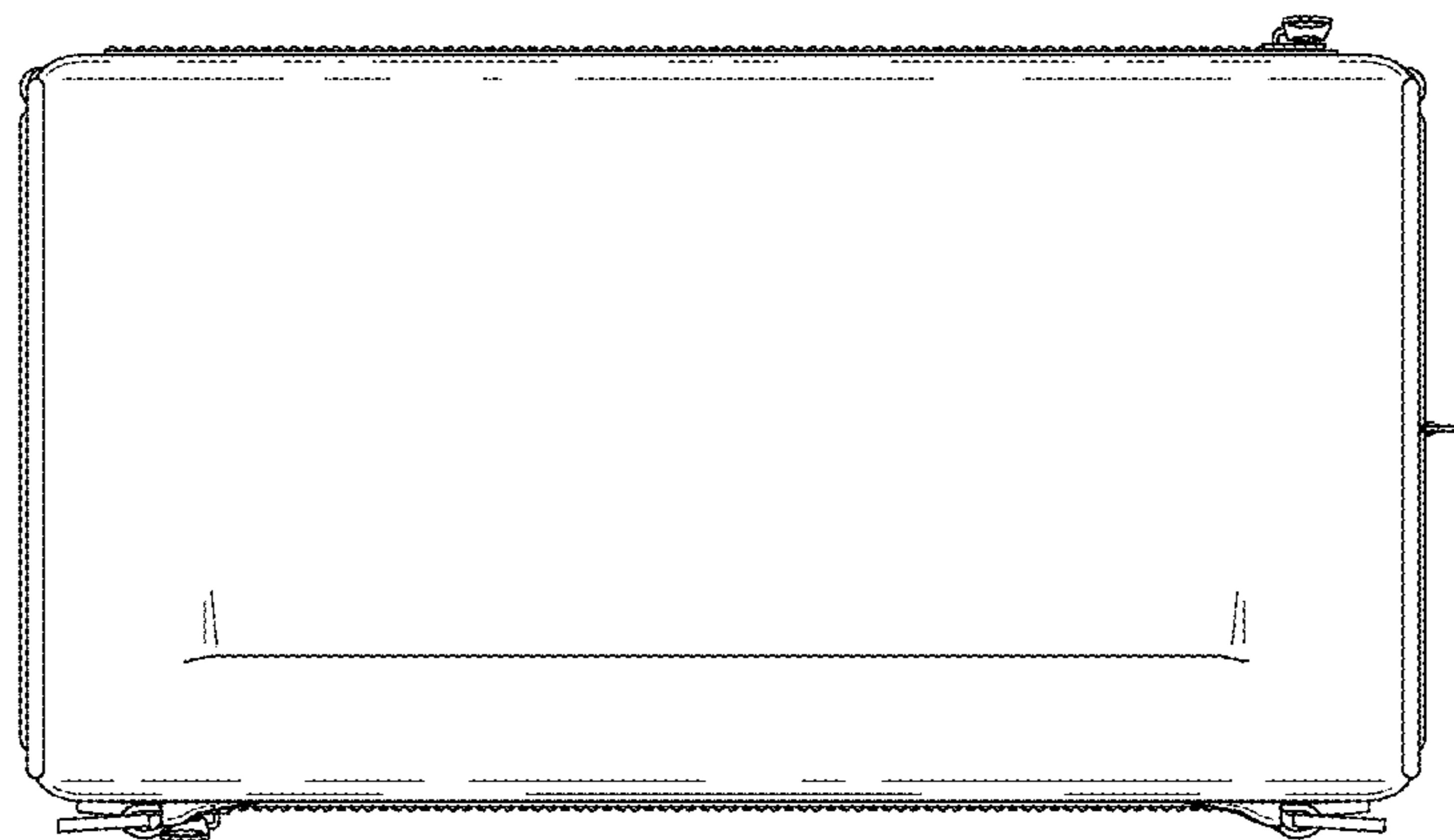

Fig. 7

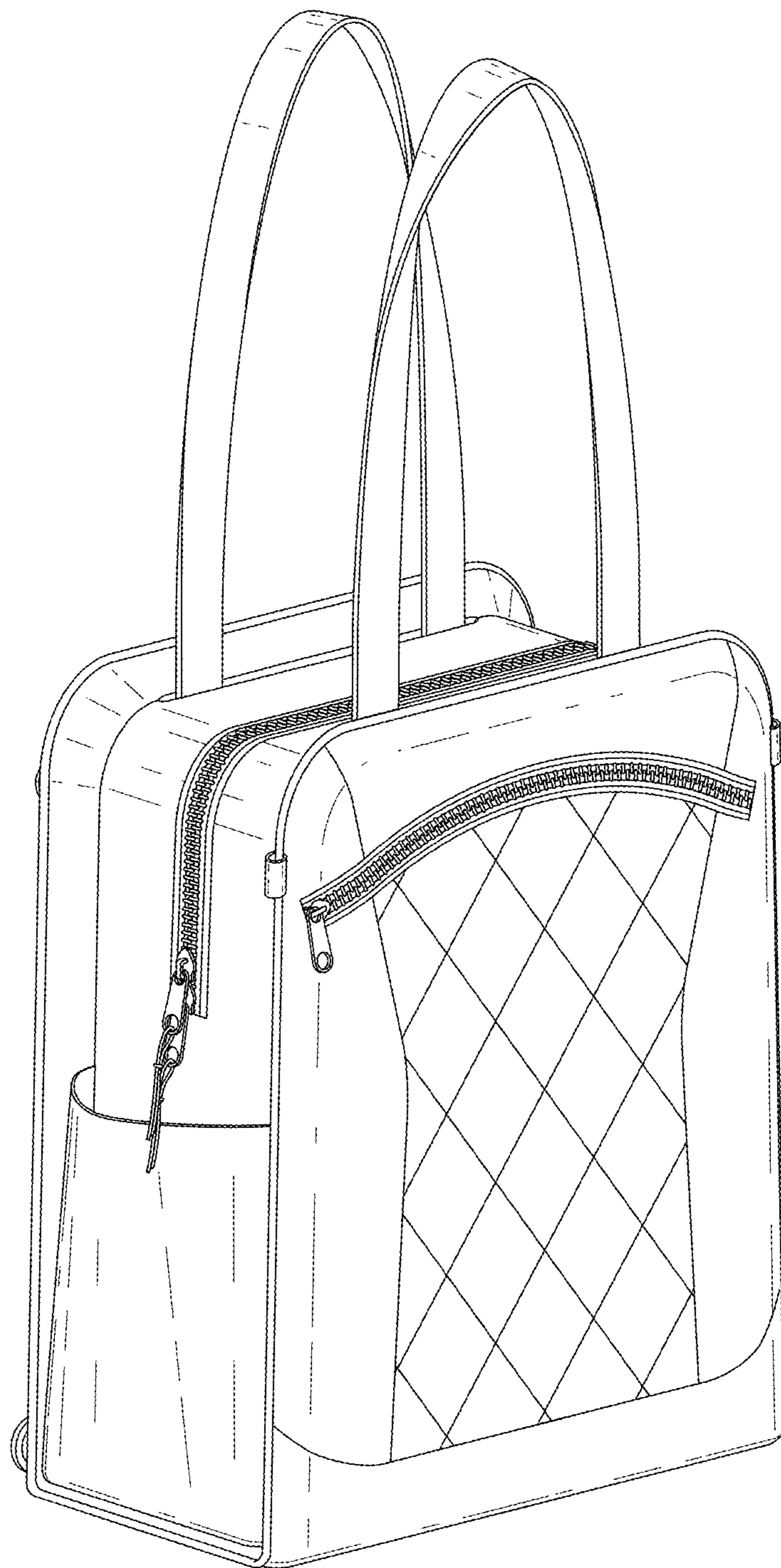

Fig. 8



Fig. 9



Fig. 10

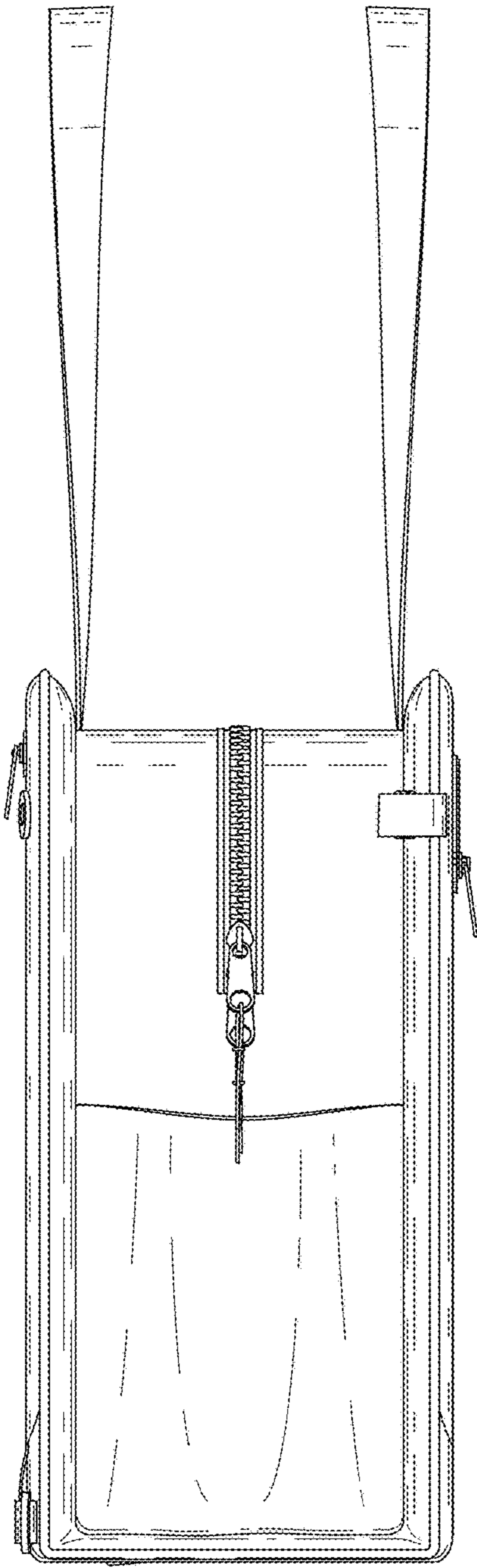

Fig. 11

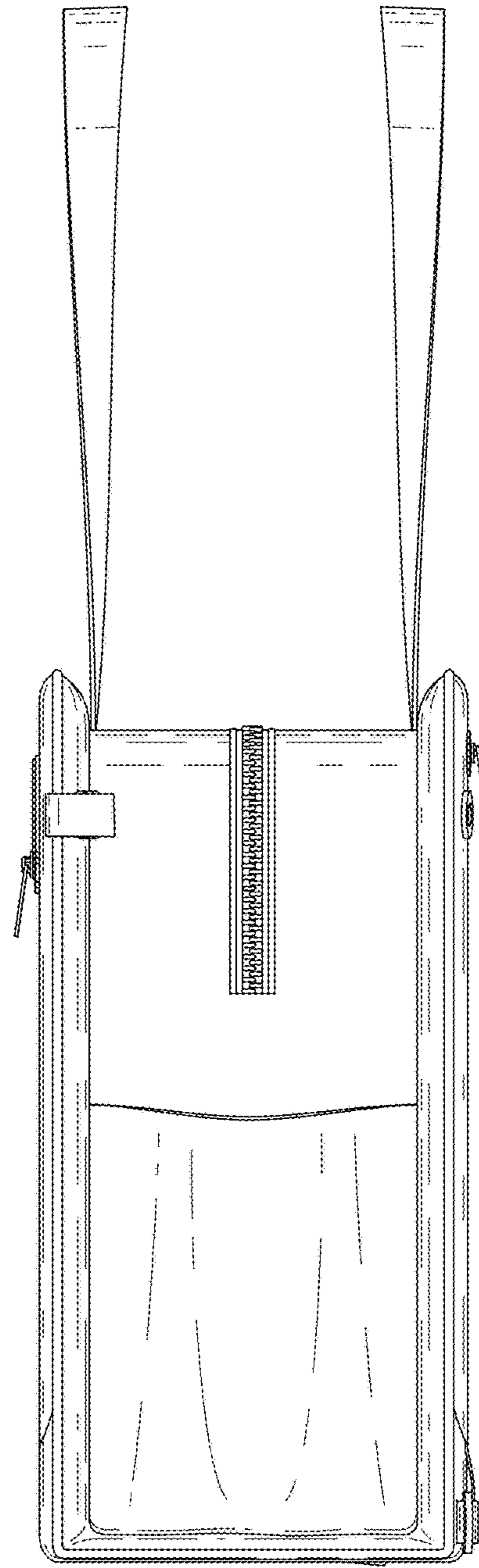

Fig. 12

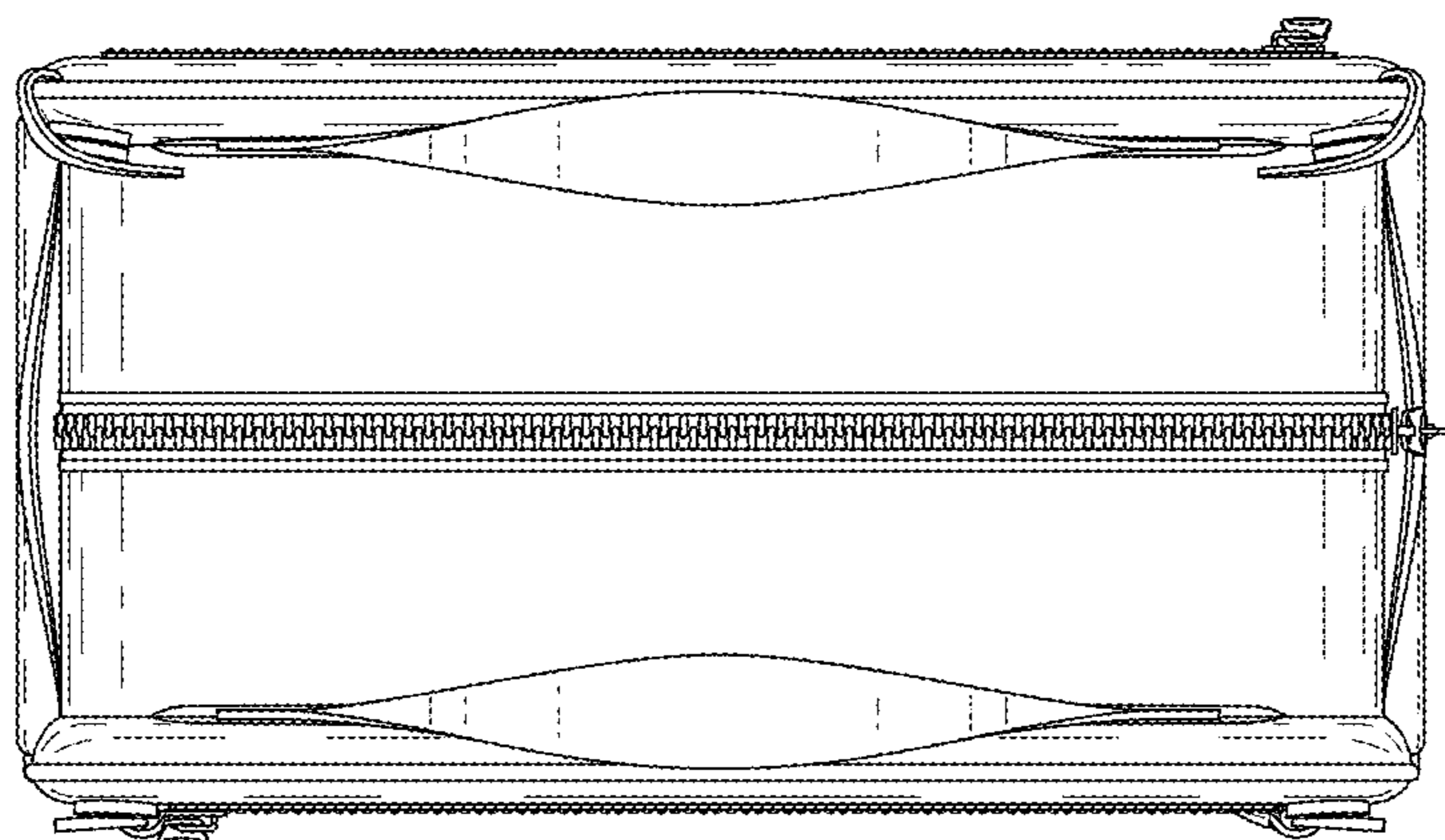

Fig. 13

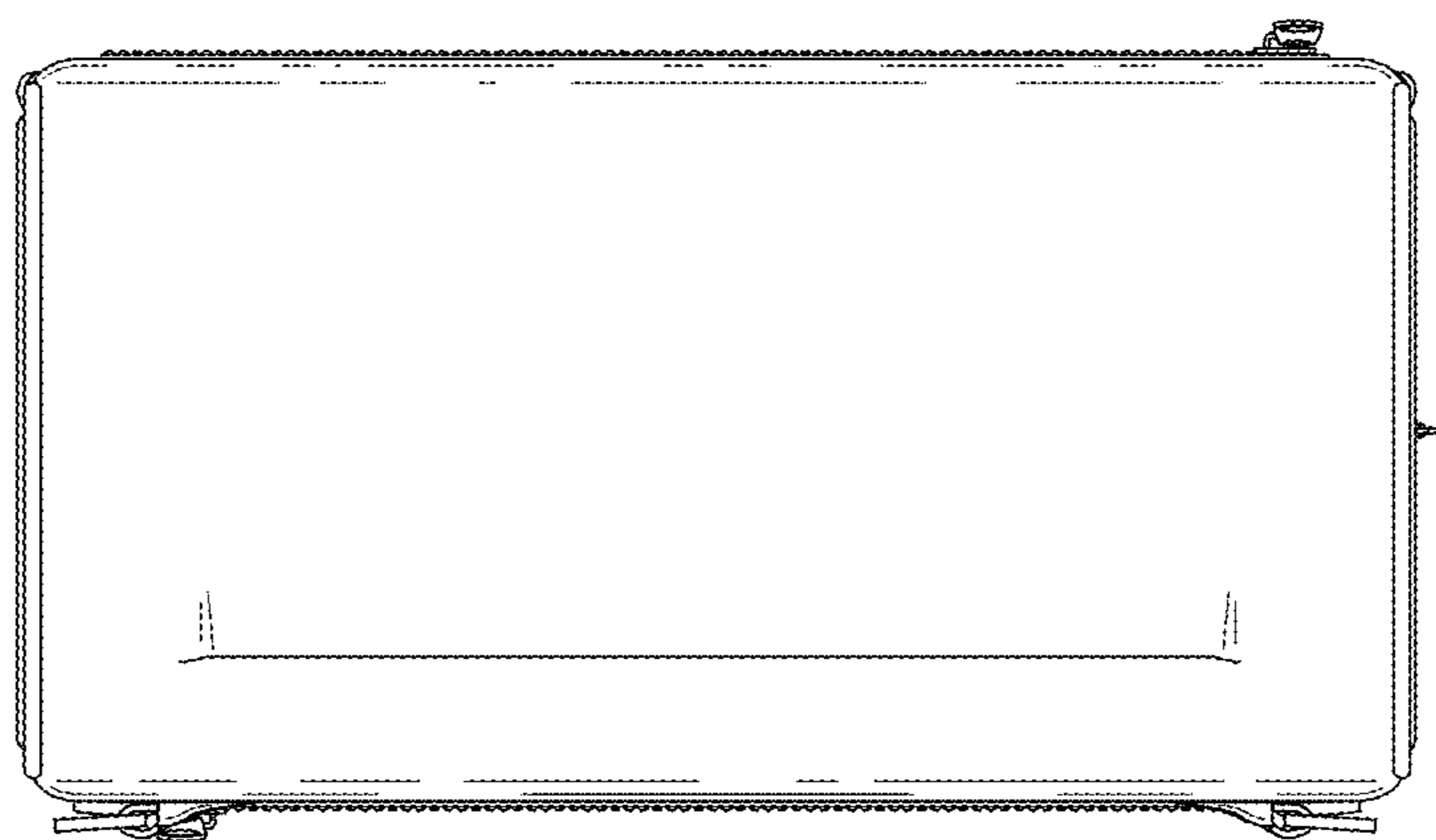

Fig. 14

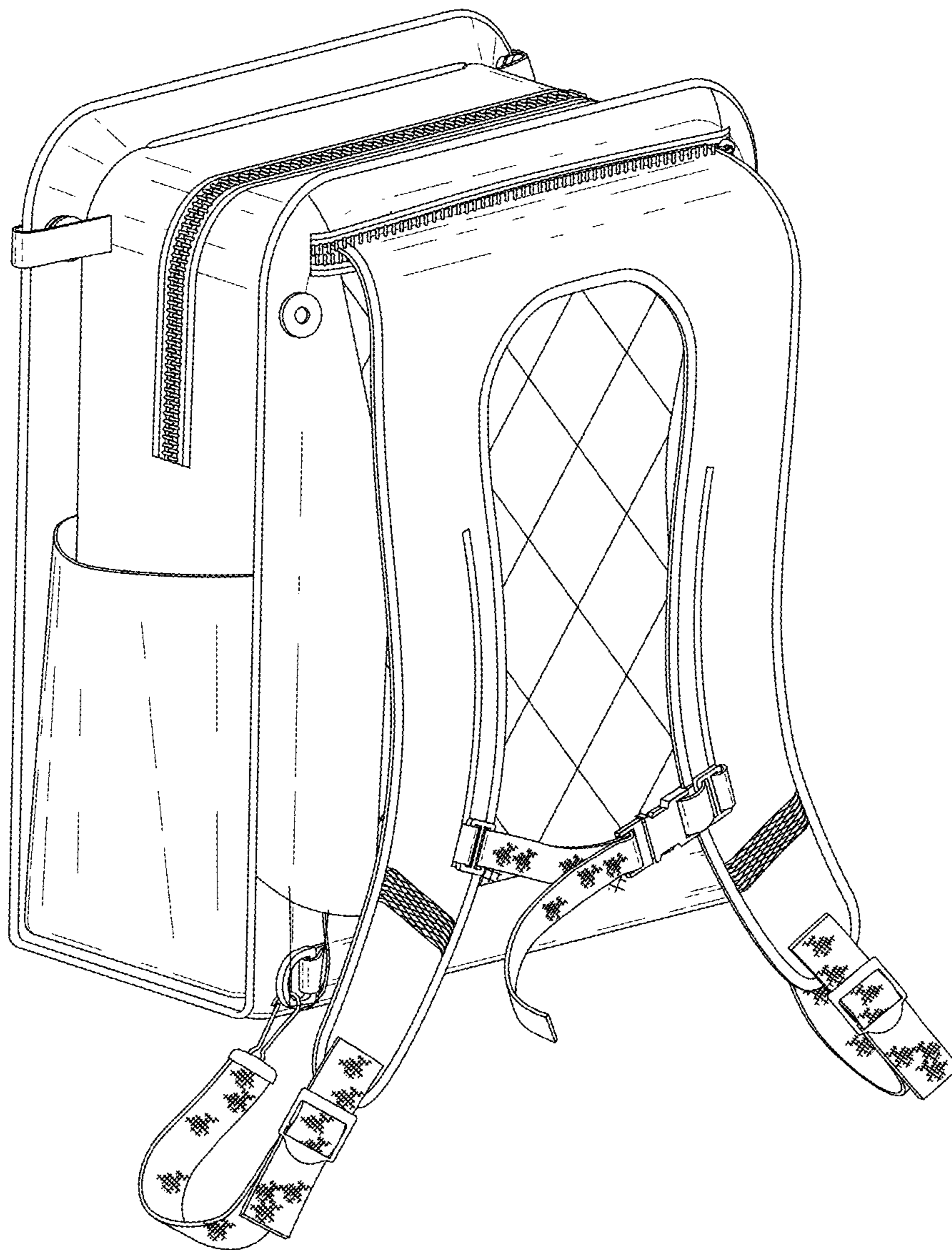

Fig. 15

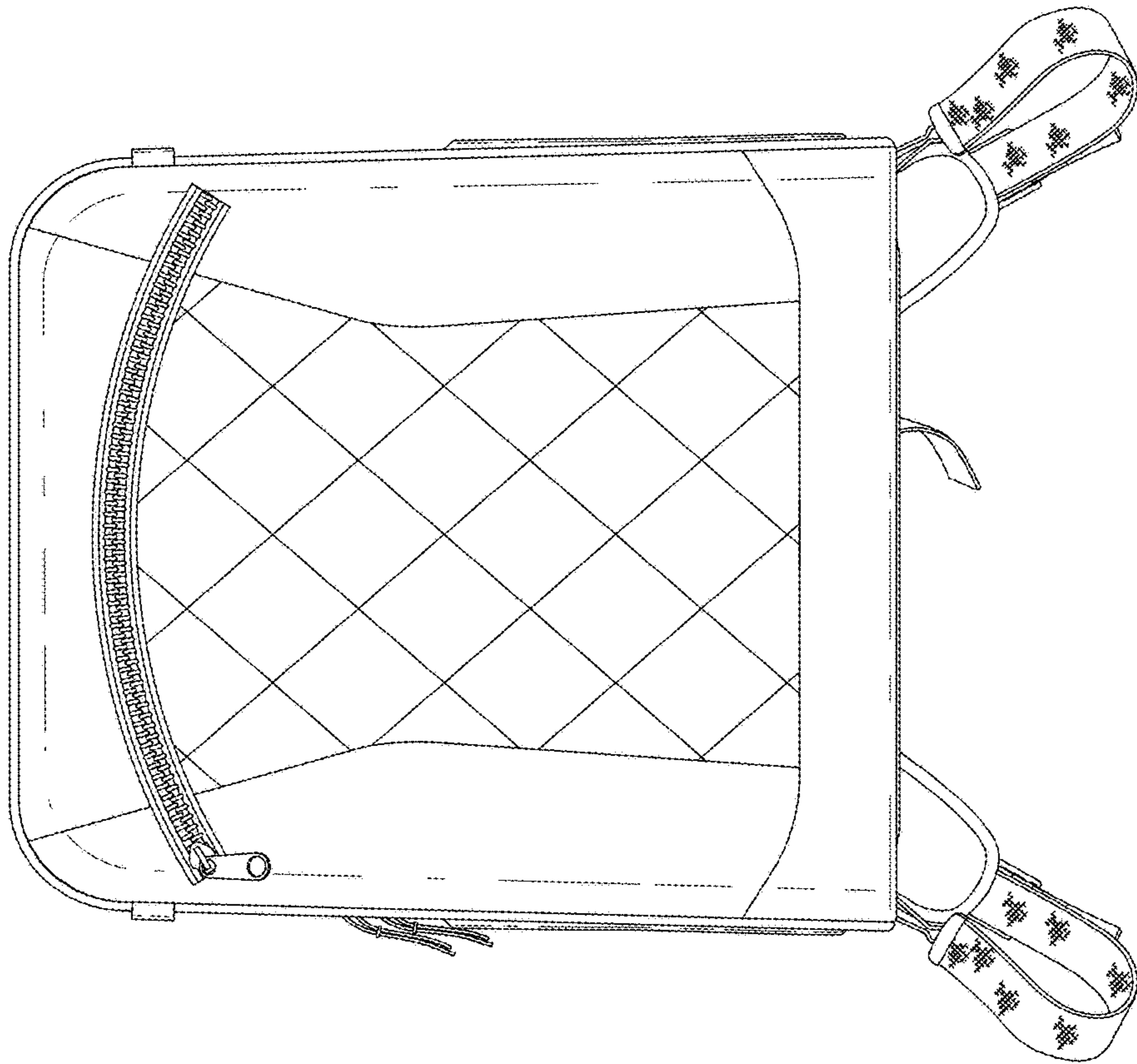

Fig. 16

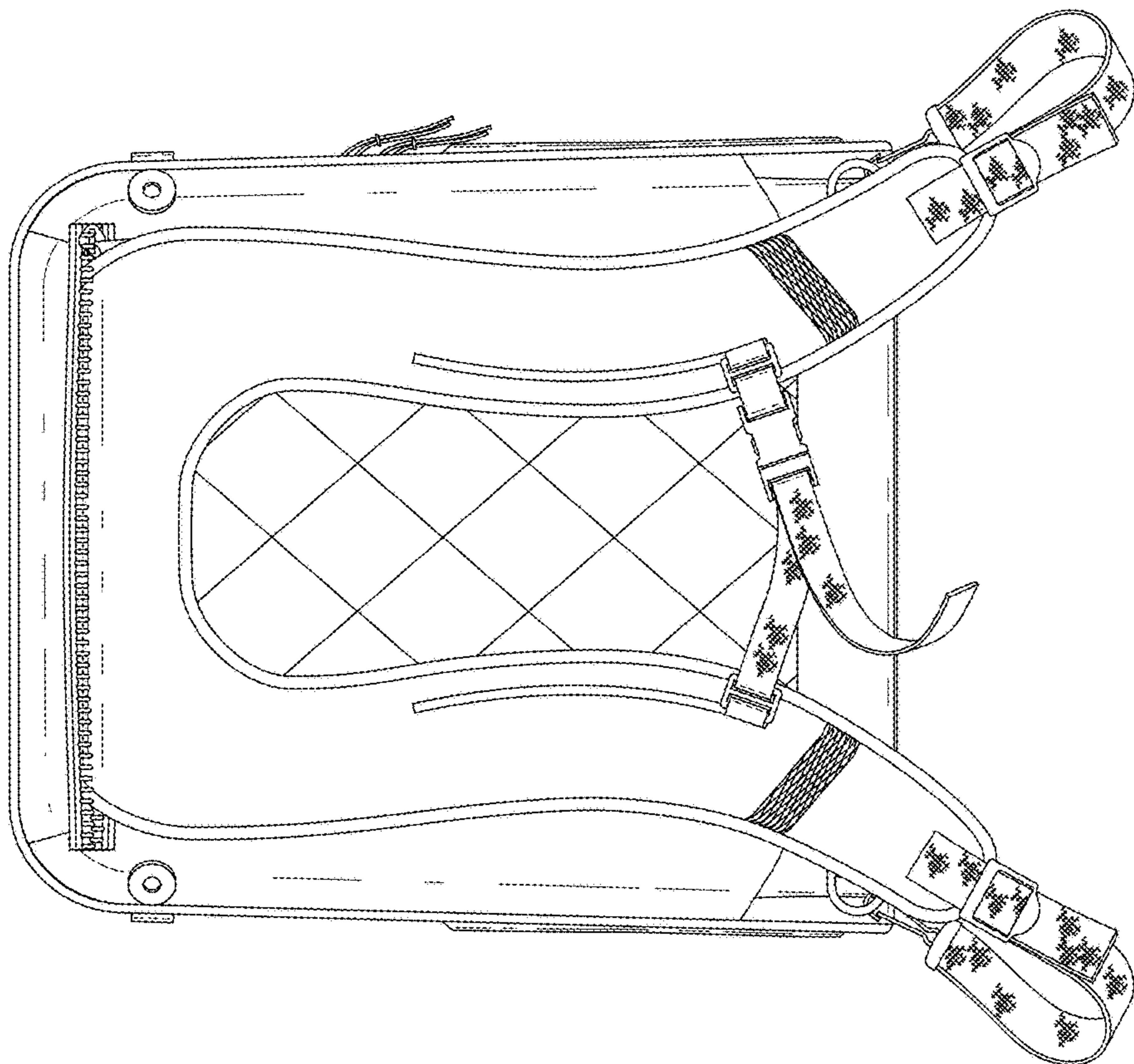

Fig. 17

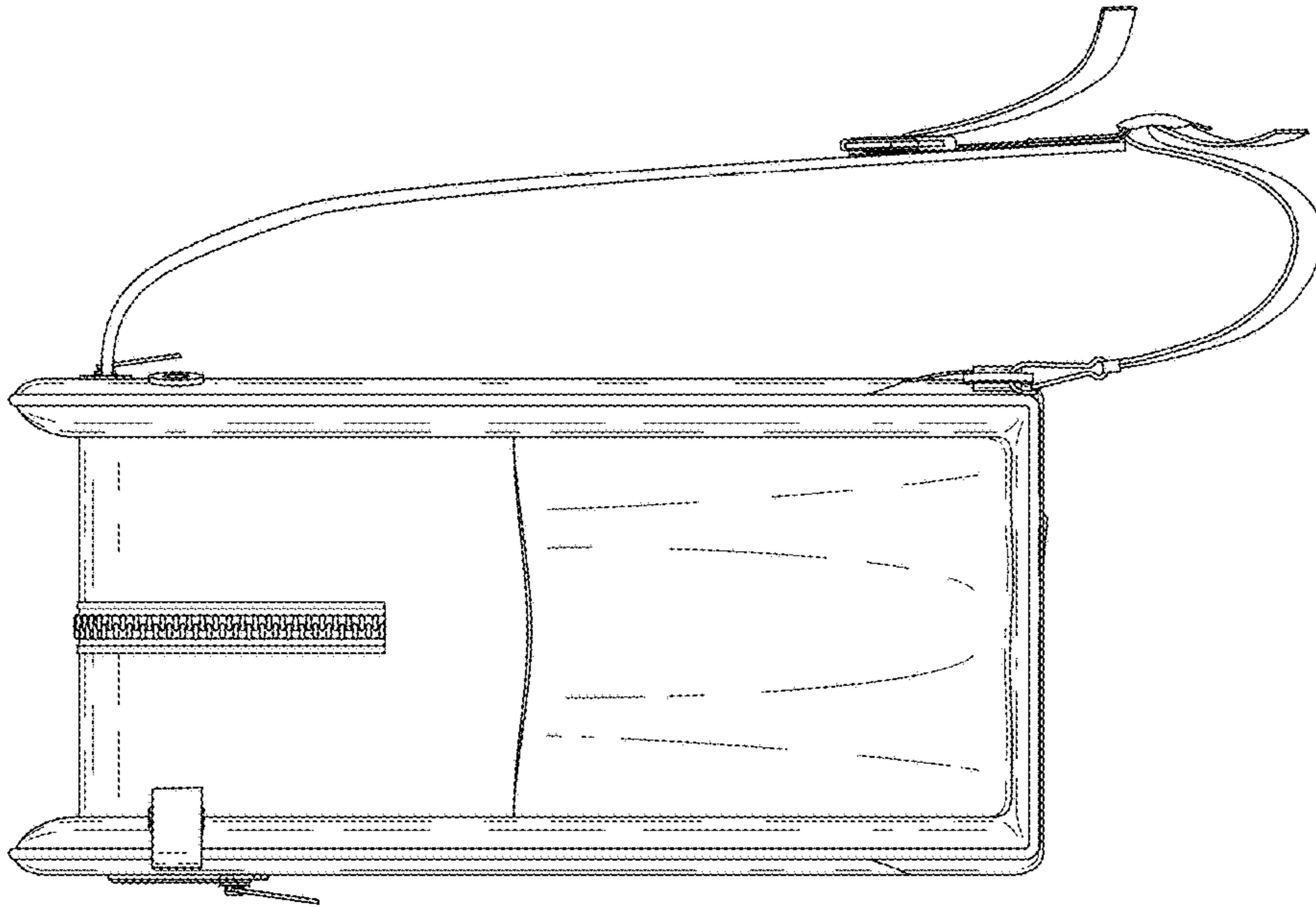

Fig. 18

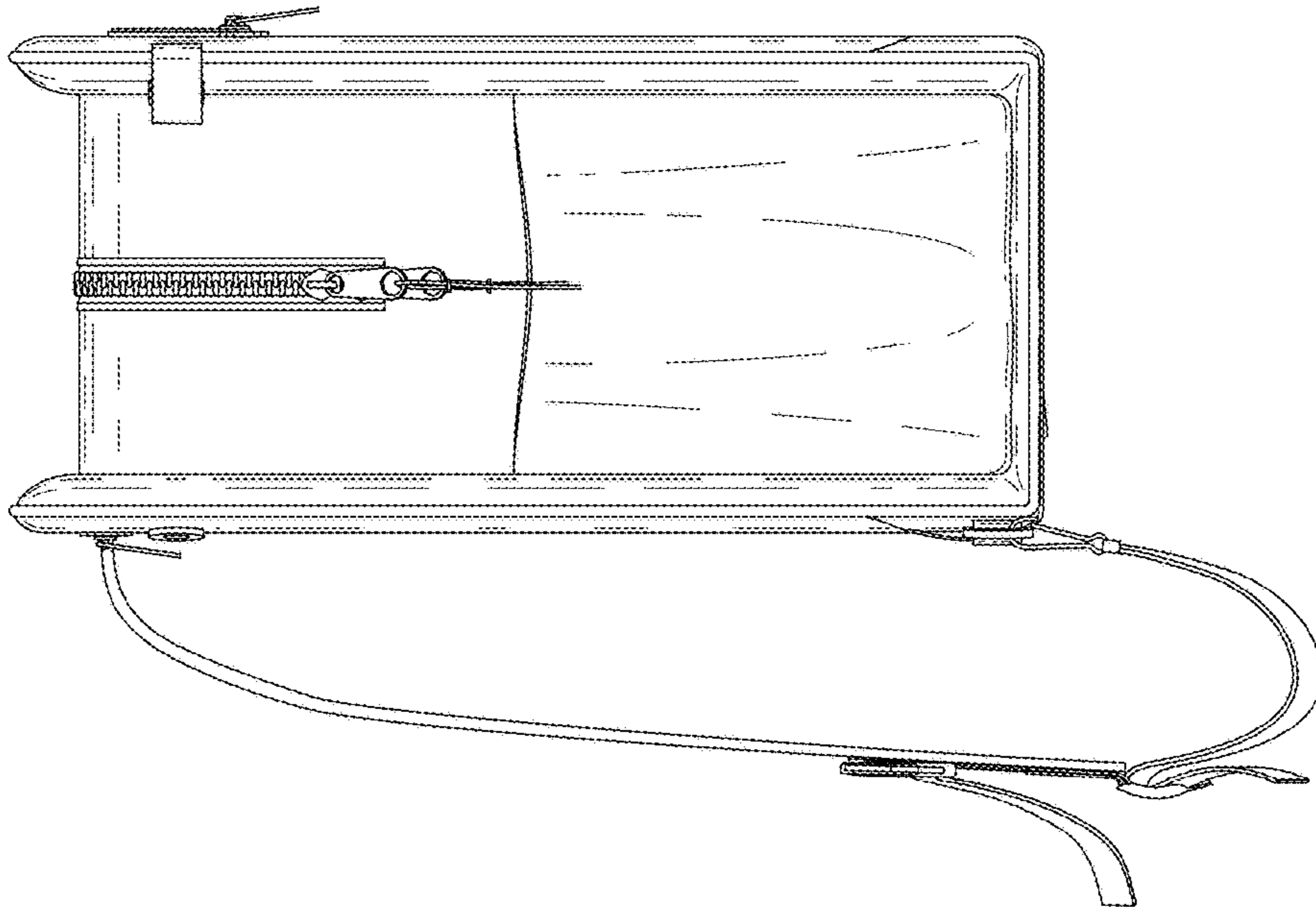

Fig. 19

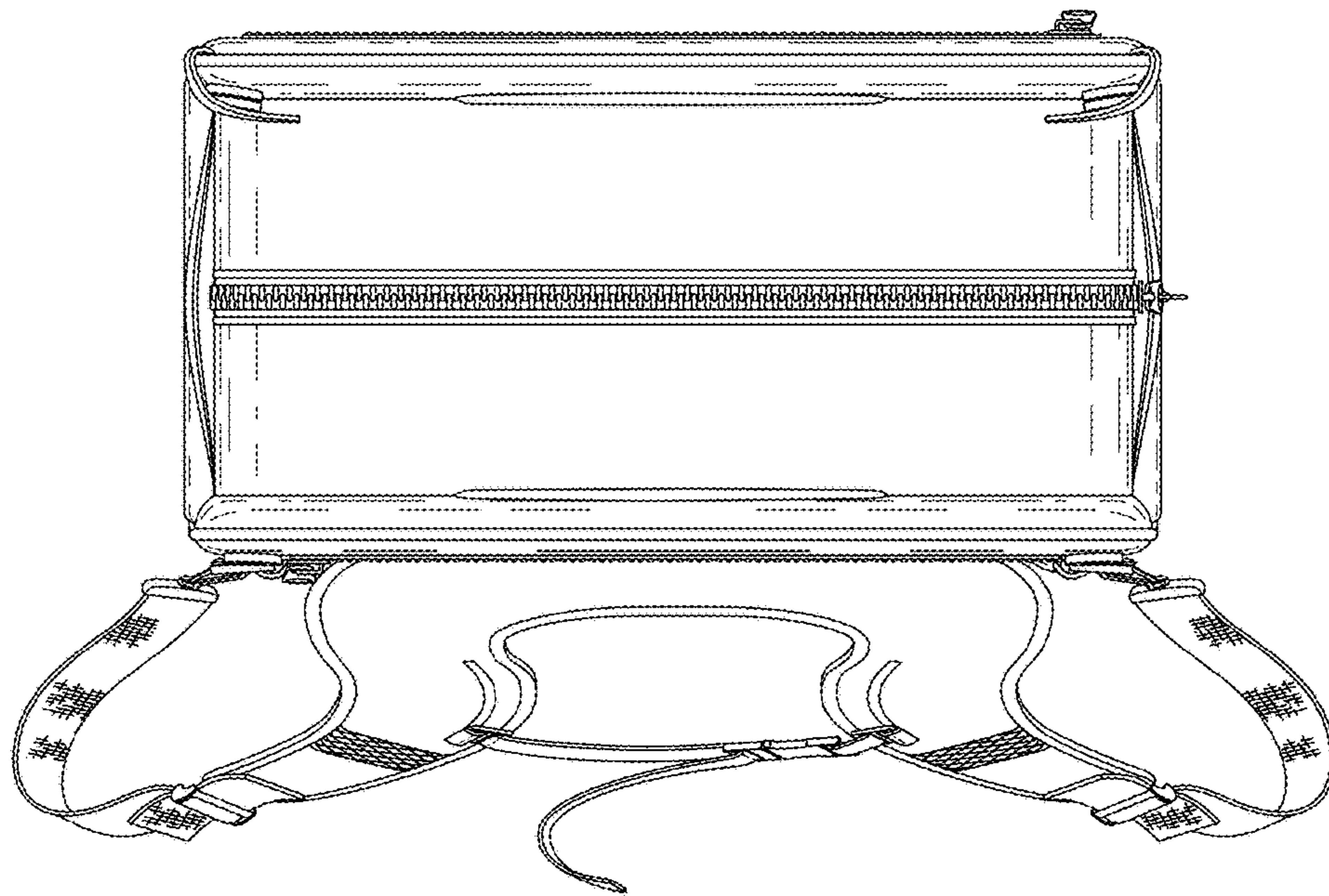

Fig. 20

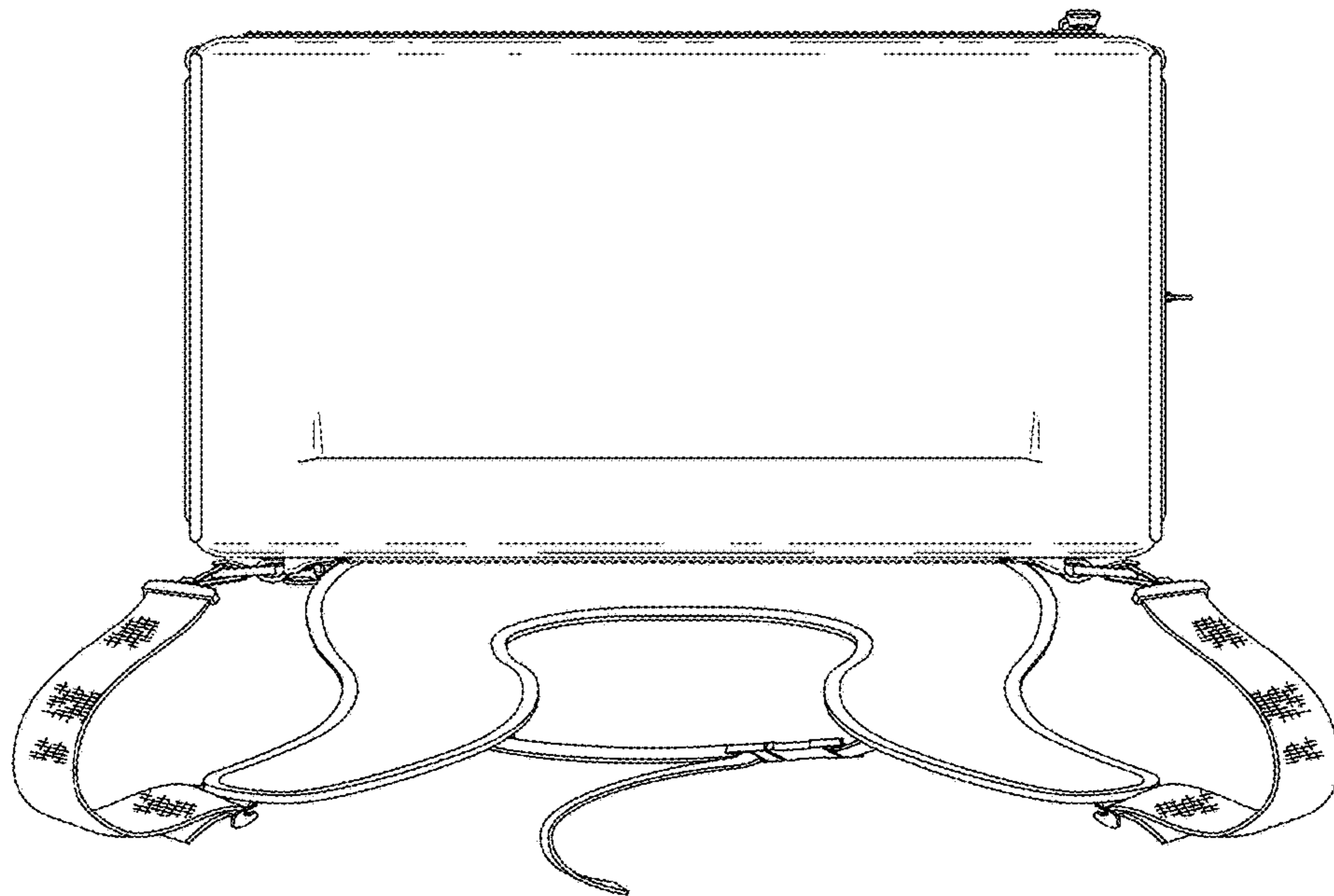

Fig. 21