



US00D791675S

(12) **United States Design Patent**
Guo

(10) **Patent No.:** **US D791,675 S**
(45) **Date of Patent:** **** Jul. 11, 2017**

(54) **VEHICLE WHEEL RIM**

(71) Applicant: **Euro Racing Wheels, LLC**, San Francisco, CA (US)

(72) Inventor: **Yong Gang Guo**, Temple City, CA (US)

(73) Assignee: **TXW WHEELS INC**, Walnut, CA (US)

(**) Term: **15 Years**

(21) Appl. No.: **29/568,824**

(22) Filed: **Jun. 21, 2016**

(51) **LOC (10) Cl.** **12-16**

(52) **U.S. Cl.**
USPC **D12/211**

(58) **Field of Classification Search**
USPC D12/204–213
CPC B60B 7/00; B60B 7/02; B60B 7/04; B60B 7/01; B60B 7/06; B60B 3/02; B60B 3/04; B60B 3/06; B60B 3/10; B60B 1/00; B60B 1/08; B60B 1/10; B60B 1/12
See application file for complete search history.

(56) **References Cited**

U.S. PATENT DOCUMENTS

D417,427 S * 12/1999 Brown D12/211
D579,845 S * 11/2008 Chung D12/209
D582,829 S * 12/2008 Musser D12/211

D625,242 S * 10/2010 Zhao D12/211
D633,028 S * 2/2011 Kim D12/211
D649,101 S * 11/2011 Hale, Jr. D12/209
D675,971 S * 2/2013 Lee D12/209
D691,543 S * 10/2013 Gordon D12/209
D695,193 S * 12/2013 Kong D12/211
D702,172 S * 4/2014 Chung D12/211
D704,118 S * 5/2014 Chung D12/209
D704,124 S * 5/2014 Hale, Jr. D12/211
D717,224 S * 11/2014 Kim D12/211
D719,893 S * 12/2014 Kim D12/211
D726,630 S * 4/2015 Kong D12/211
D741,770 S * 10/2015 Kim D12/209
D746,753 S * 1/2016 Johnson D12/209
D764,375 S * 8/2016 Chung D12/211

* cited by examiner

Primary Examiner — Stacia Cadmus

(74) *Attorney, Agent, or Firm* — Michael F. Fedrick; Loza & Loza, LLP

(57) **CLAIM**

The ornamental design for a vehicle wheel rim, as shown and described.

DESCRIPTION

FIG. 1 is a front view of the vehicle wheel rim of the present invention;
FIG. 2 is a front, left side perspective view thereof;
FIG. 3 is a front, right side perspective view thereof;
FIG. 4 is a front, bottom perspective view thereof; and,
FIG. 5 is a side view thereof.

1 Claim, 5 Drawing Sheets

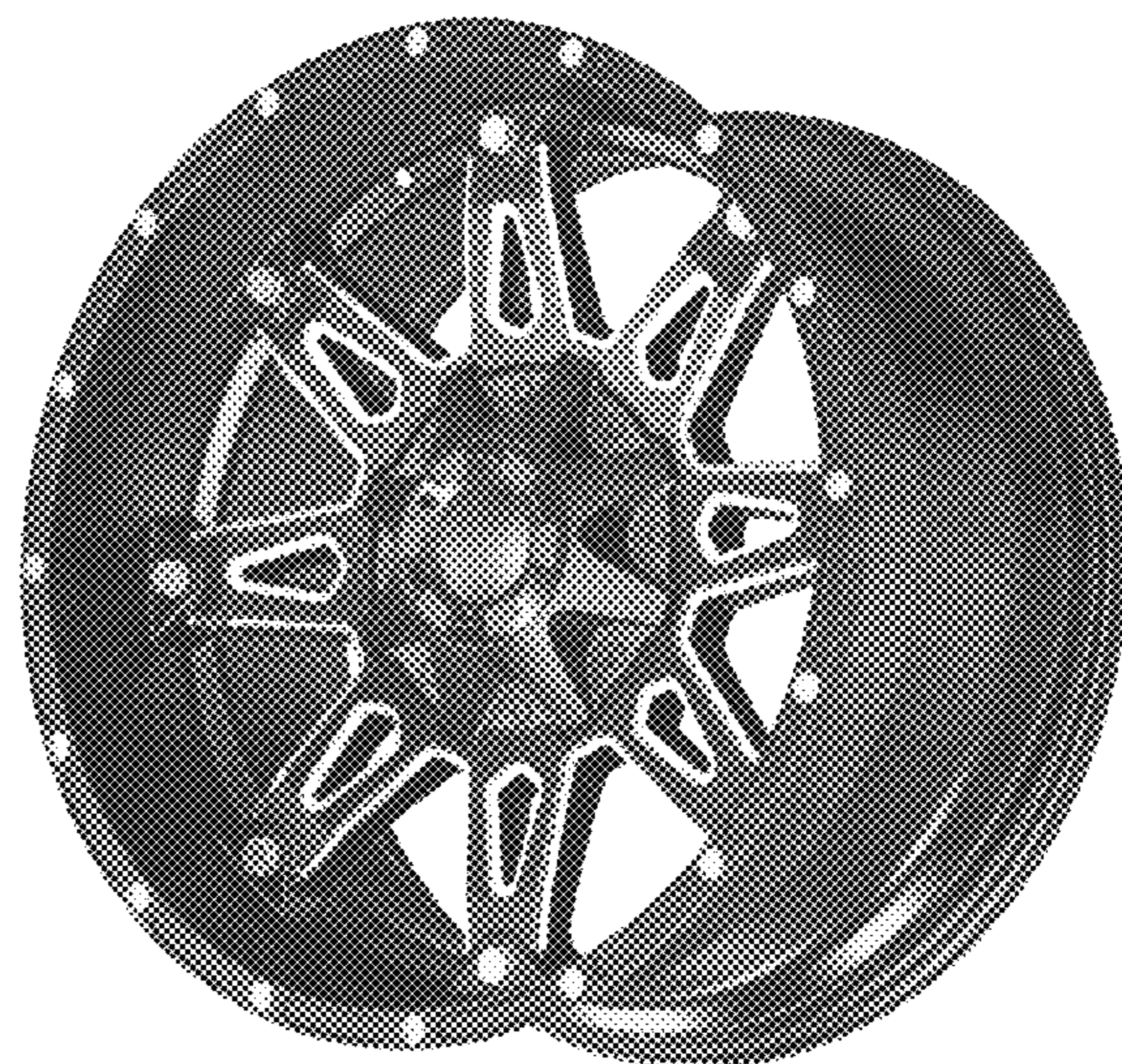
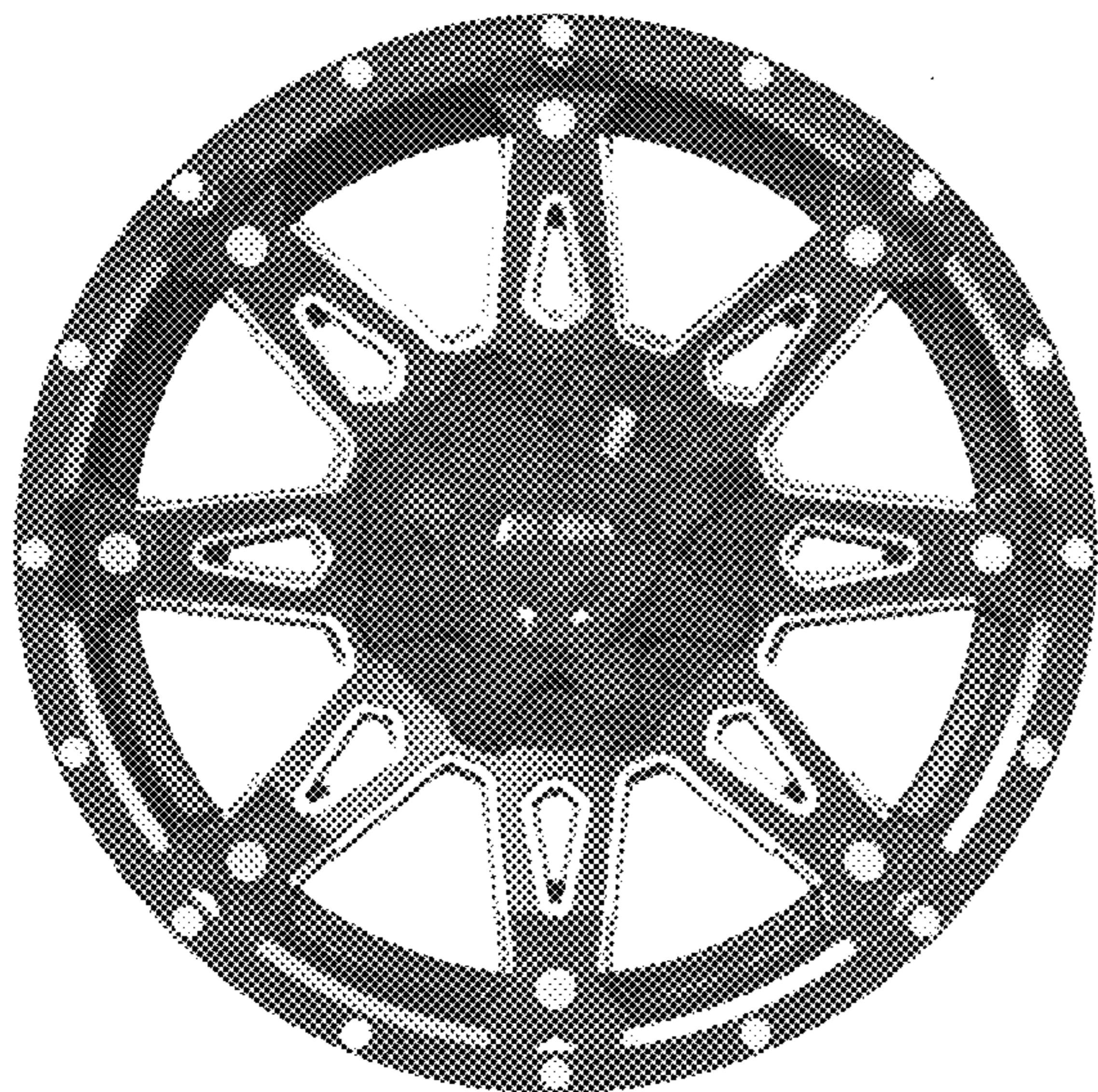

Figure 1



Figure 2



Figure 3



Figure 4



Figure 5

