



US00D791629S

(12) **United States Design Patent**  
**Haworth et al.**

(10) **Patent No.:** **US D791,629 S**

(45) **Date of Patent:** **\*\* Jul. 11, 2017**

(54) **FLUID LEVEL INDICATOR**

(71) Applicants: **Jon Haworth**, Hendersonville, TN (US); **Houston Hatchett**, Franklin, TN (US); **Keith Mawdsley**, Hendersonville, TN (US)

(72) Inventors: **Jon Haworth**, Hendersonville, TN (US); **Houston Hatchett**, Franklin, TN (US); **Keith Mawdsley**, Hendersonville, TN (US)

(73) Assignee: **Des-Case Corporation**, Goodlettsville, TN (US)

(\*\*) Term: **15 Years**

(21) Appl. No.: **29/542,778**

(22) Filed: **Oct. 16, 2015**

(51) **LOC (10) Cl.** ..... **10-04**

(52) **U.S. Cl.**  
USPC ..... **D10/101; D10/102; D16/134; D23/249**

(58) **Field of Classification Search**  
USPC ..... **D10/56, 101, 102; D16/134, 135; D23/249**

CPC ..... **G01F 23/02; G01N 1/10**  
See application file for complete search history.

(56) **References Cited**

**U.S. PATENT DOCUMENTS**

D243,172 S *	1/1977	Uetake	.....	D16/134
D606,439 S *	12/2009	Yan	.....	D10/101
D742,265 S *	11/2015	Harck	.....	D10/103
D758,229 S *	6/2016	Cardinal	.....	D10/106.2
2014/0238156 A1 *	8/2014	Aljohani	.....	G01N 1/10 73/864.63

**OTHER PUBLICATIONS**

“Inspection for Success with Visual Oil Analysis” from Uptime Magazine, Oct./Nov. 14, written by Mark Barnes.

“Oil Inspection Sigh Glasses” from Clean Lube Solutions. Luneta Sight Glass, at <http://www.luneta.com/products/sight-glass?variant=2645650435>.

U.S. Appl. No. 29/542,772, filed Oct. 16, 2015.

U.S. Appl. No. 29/542,777, filed Oct. 16, 2015.

U.S. Appl. No. 29/542,775, filed Oct. 16, 2015.

\* cited by examiner

*Primary Examiner* — Antoine D Davis

(74) *Attorney, Agent, or Firm* — Patterson Intellectual Property Law, P.C.; Ryan D. Levy

(57) **CLAIM**

The ornamental design for a fluid level indicator, as shown and described.

**DESCRIPTION**

FIG. 1 is a side perspective view of an embodiment of the fluid level indicator of Applicants’ invention.

FIG. 2 is a side view of an embodiment of the fluid level indicator of Applicants’ invention.

FIG. 3 is a bottom perspective view of an embodiment of the fluid level indicator of Applicants’ invention.

FIG. 4 is a top view of an embodiment of the fluid level indicator of Applicants’ invention.

FIG. 5 is a side view of an embodiment of the fluid level indicator of Applicants’ invention.

FIG. 6 is a bottom view of an embodiment of the fluid level indicator of Applicants’ invention.

FIG. 7 is a side view of an embodiment of the fluid level indicator of Applicants’ invention.

FIG. 8 is a side view of an embodiment of the fluid level indicator of Applicants’ invention; and,

FIG. 9 is a cut-a-way side view of a portion of an embodiment of the fluid level indicator of Applicants’ invention.

The broken lines depict portions of the fluid level indicator that form no part of the claimed design.

**1 Claim, 1 Drawing Sheet**

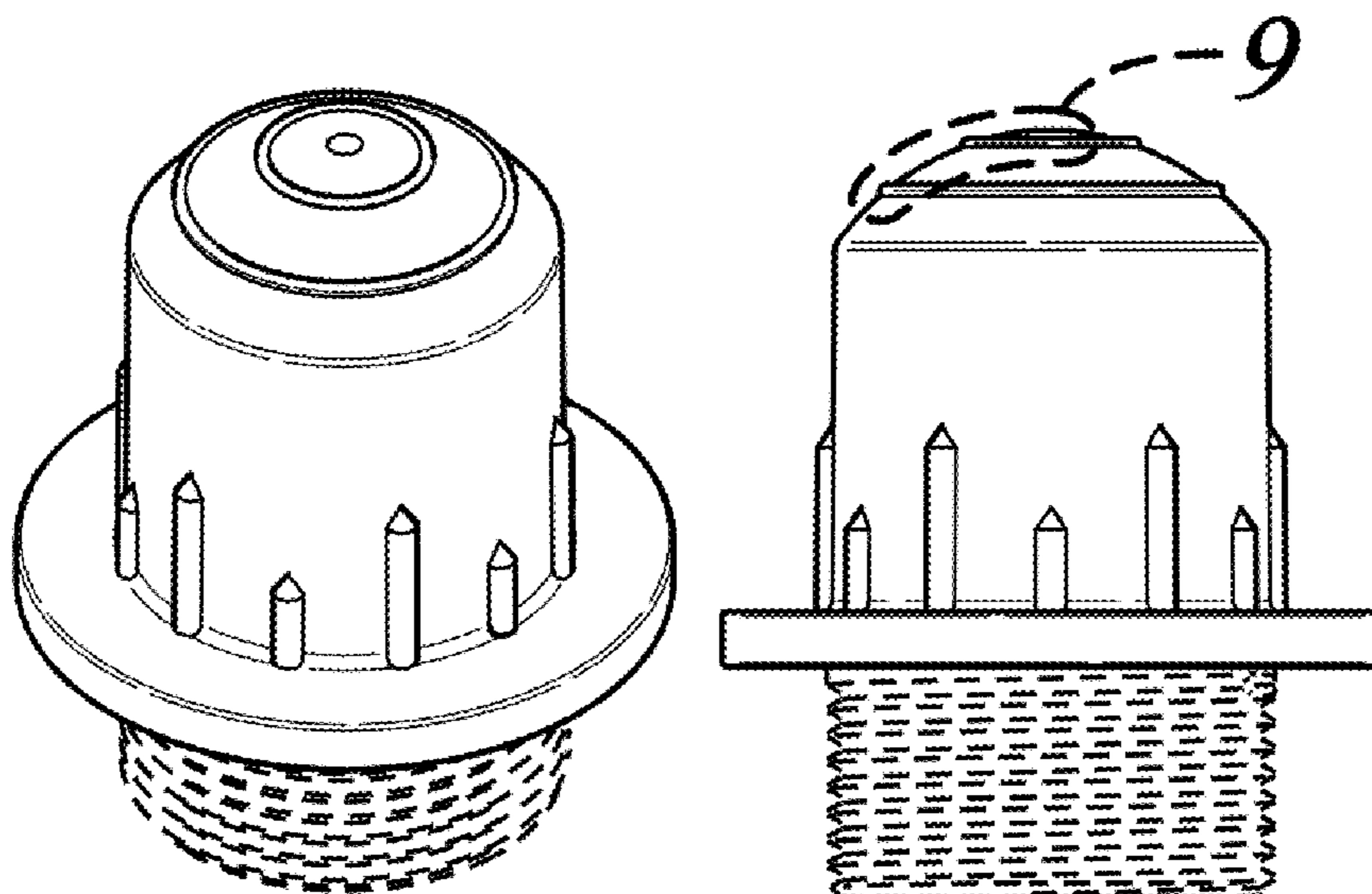

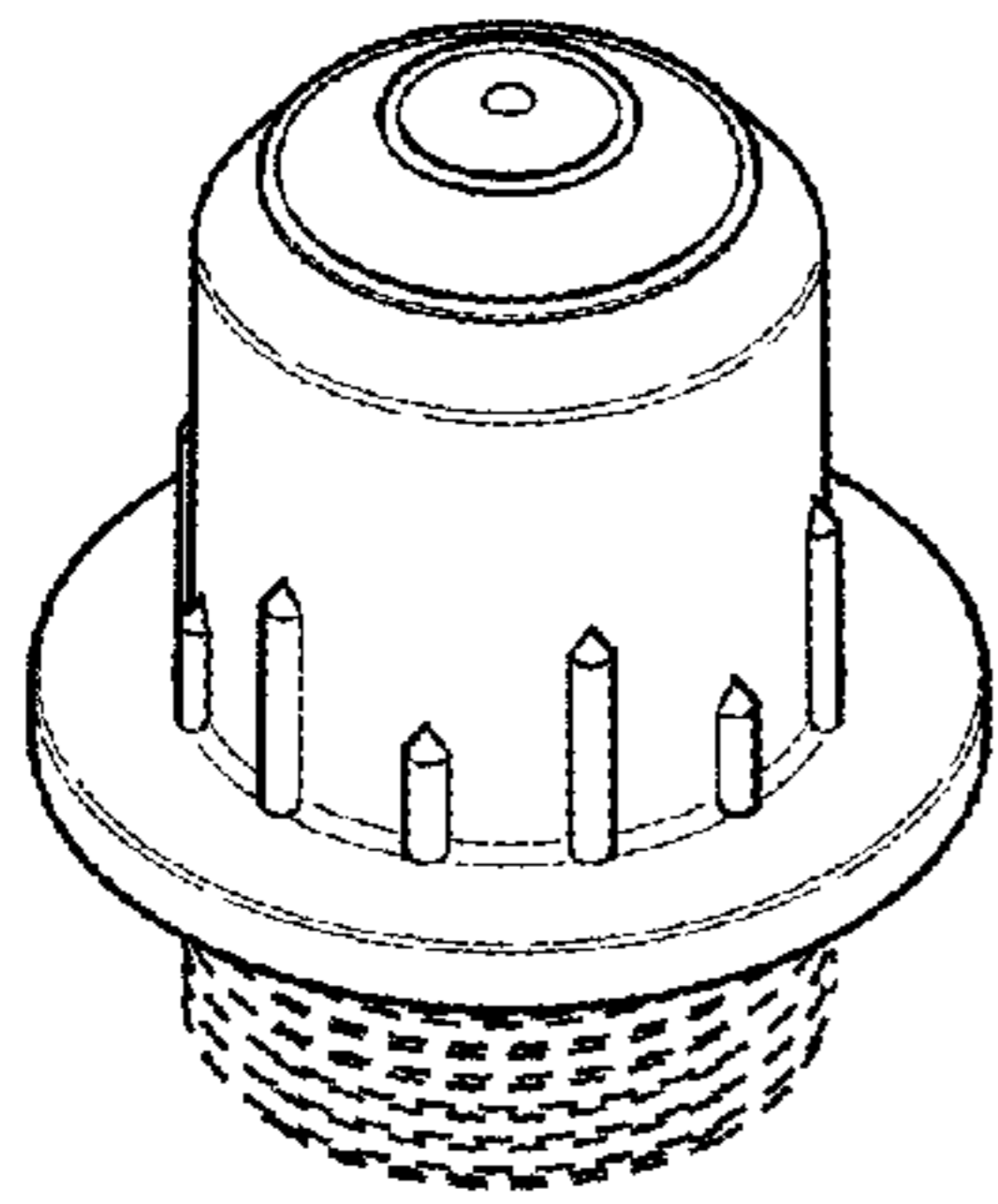

FIG. 1

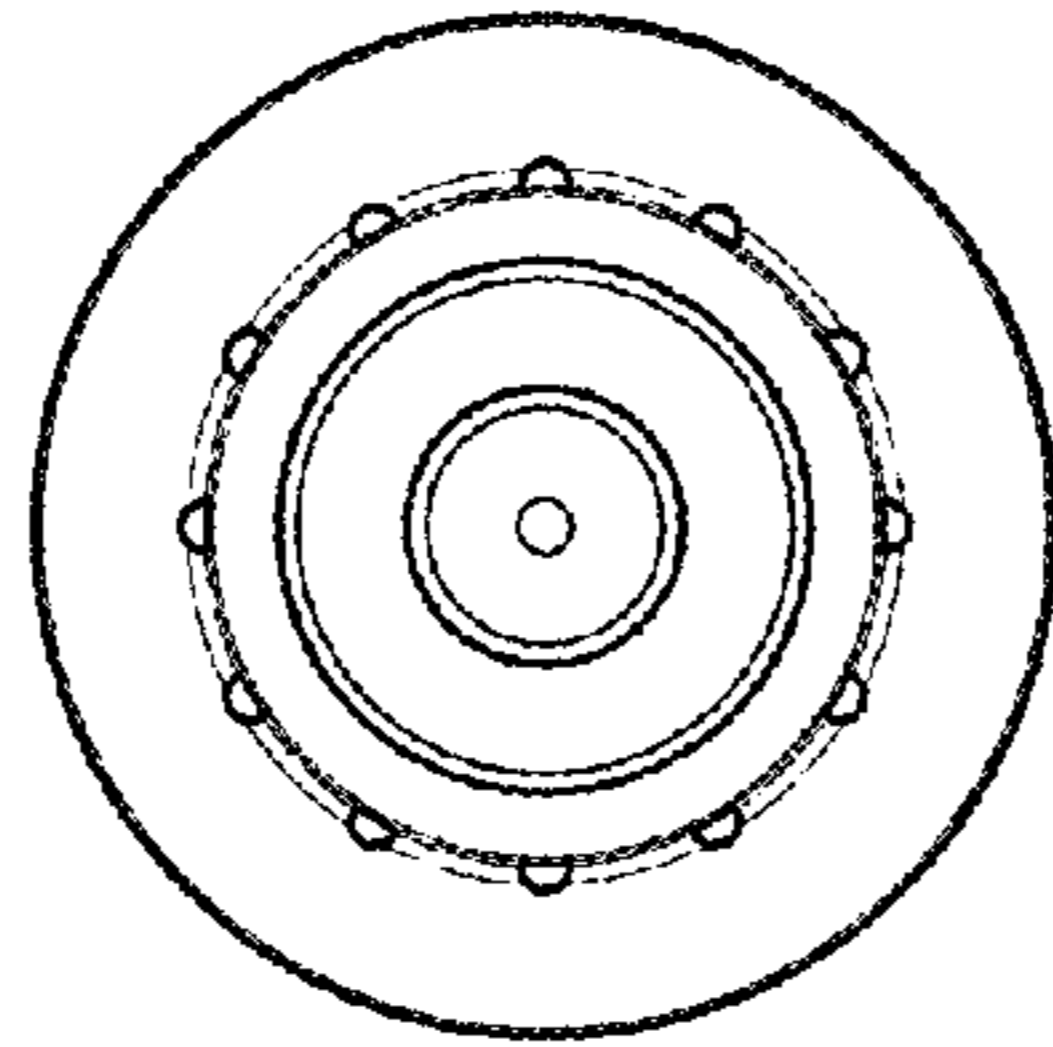

FIG. 4

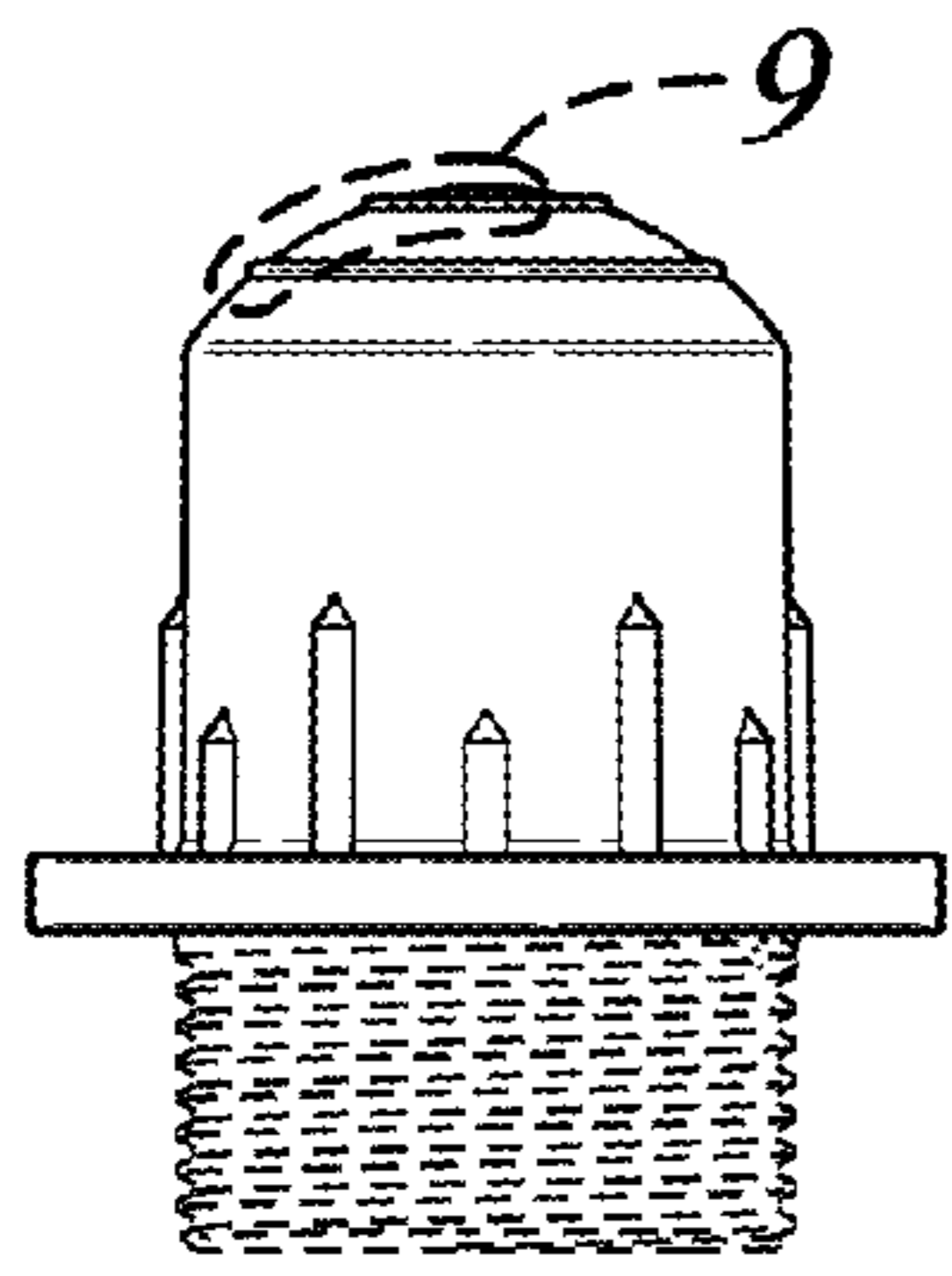

FIG. 2

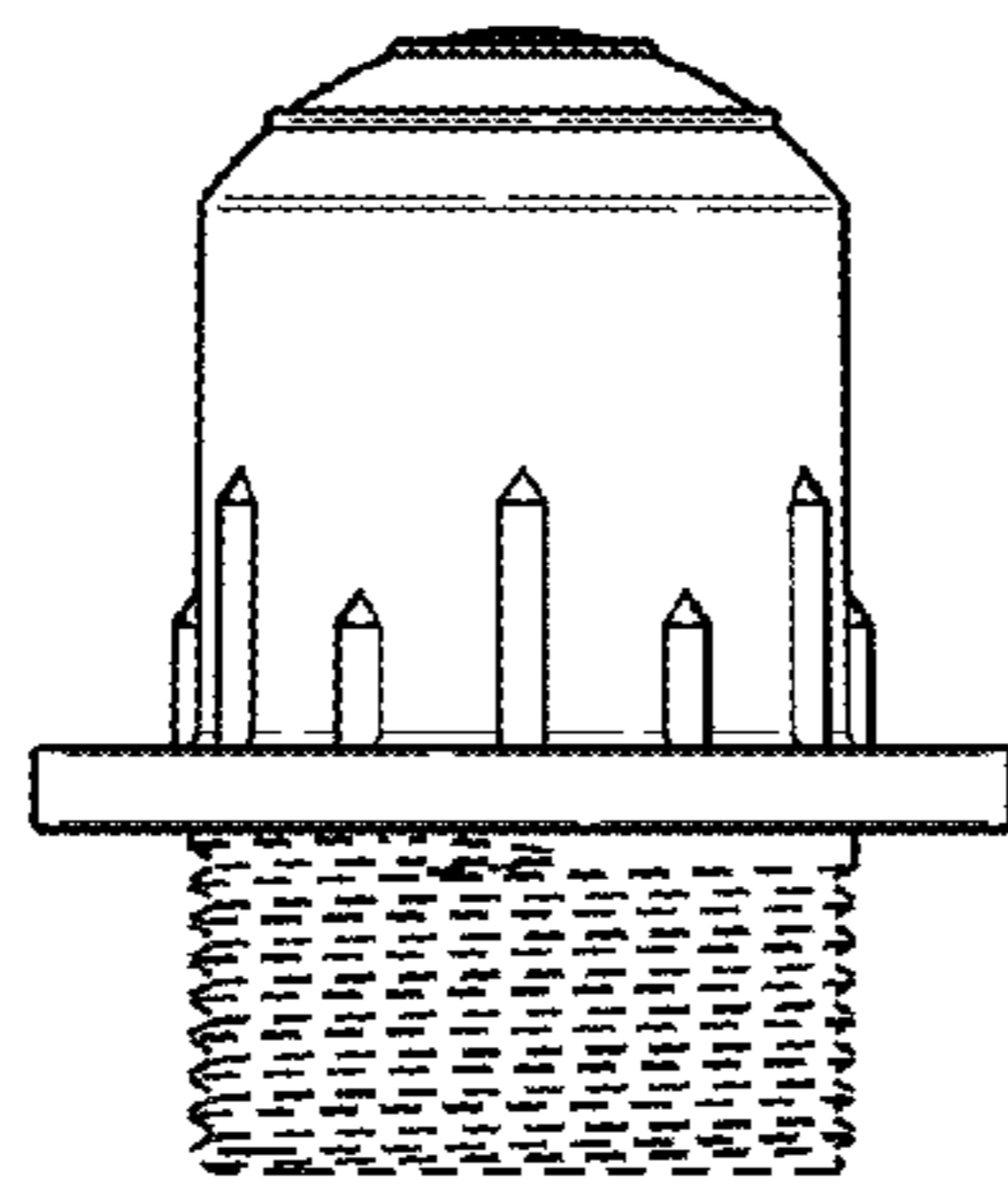

FIG. 5

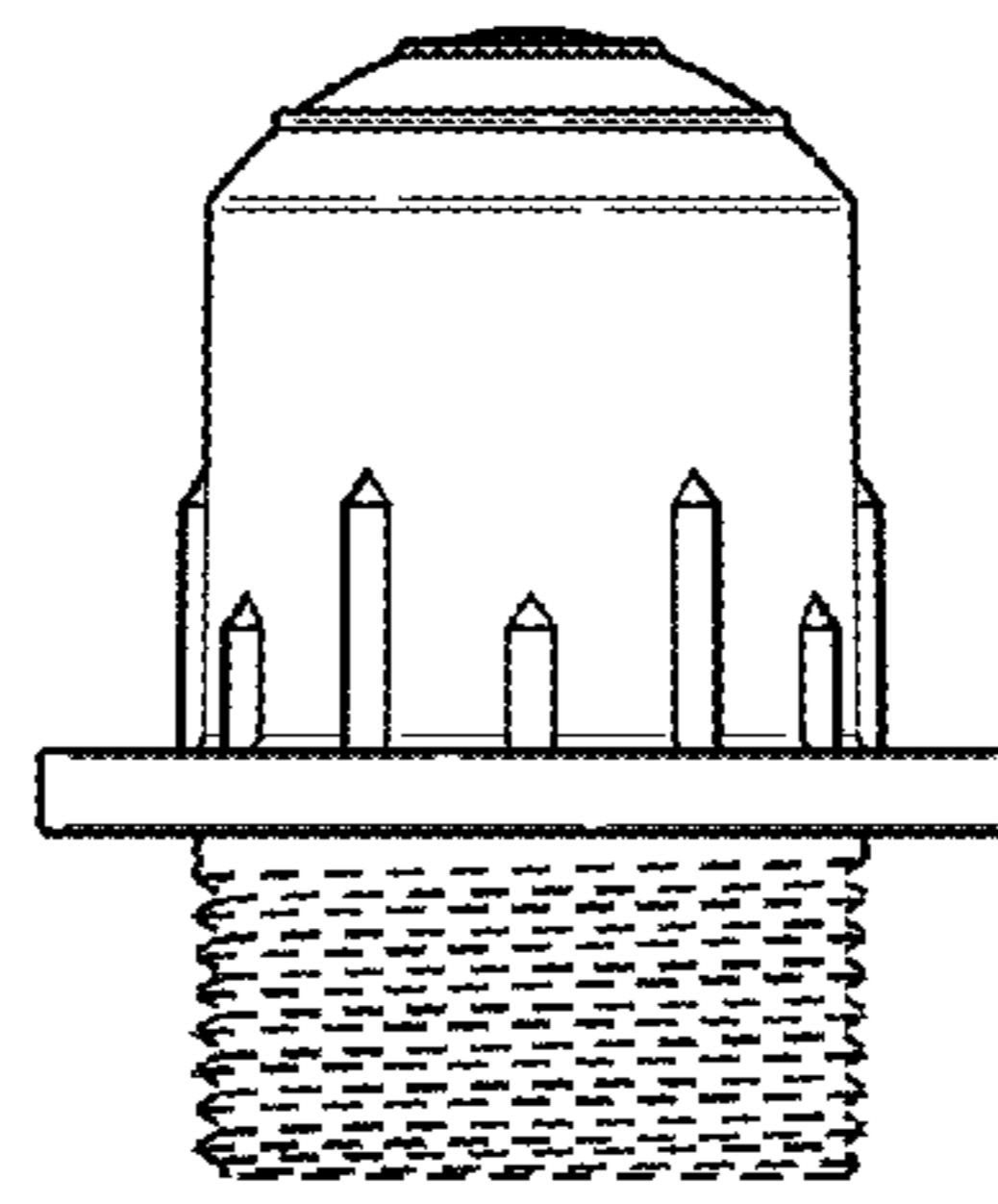

FIG. 7

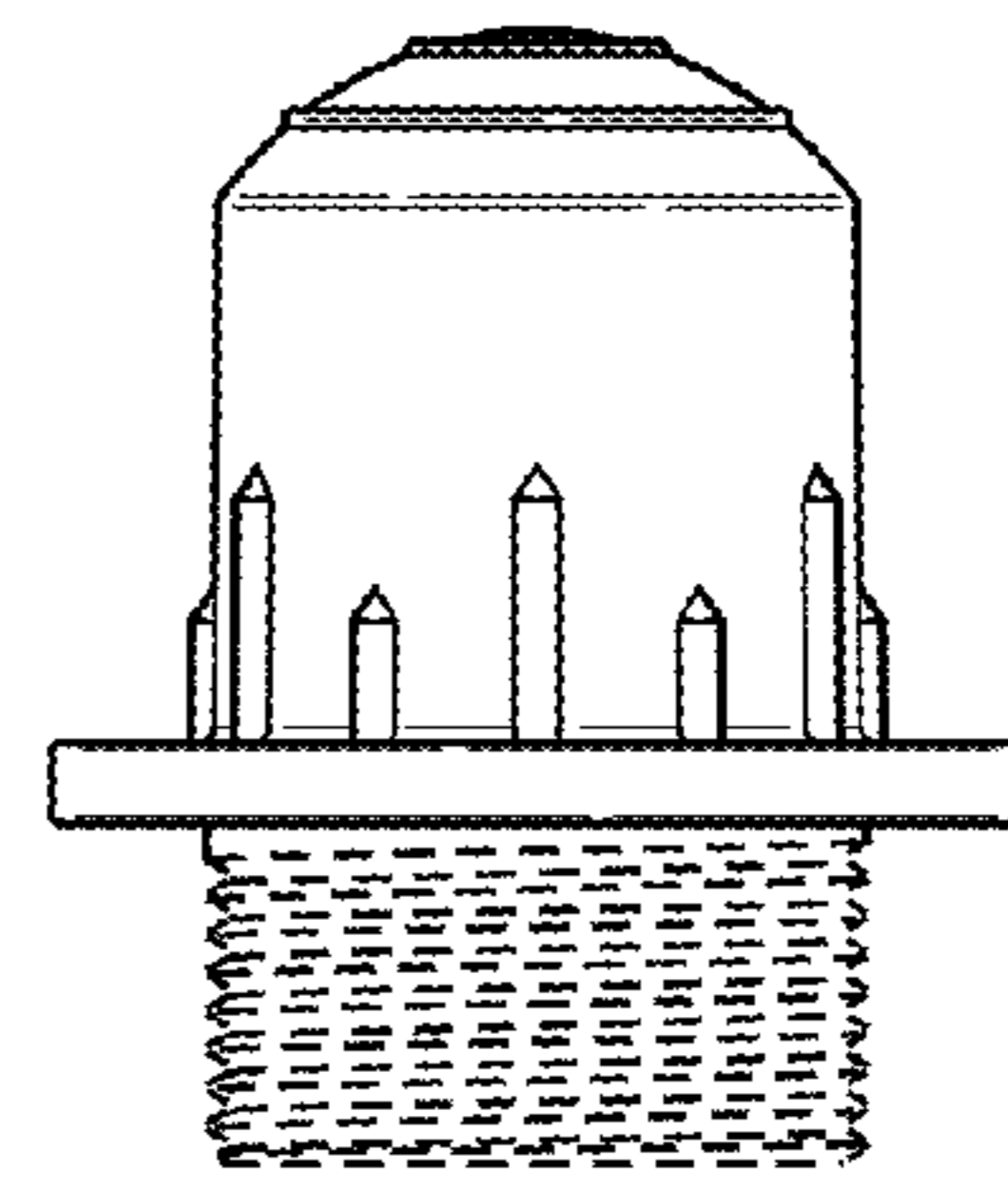

FIG. 8

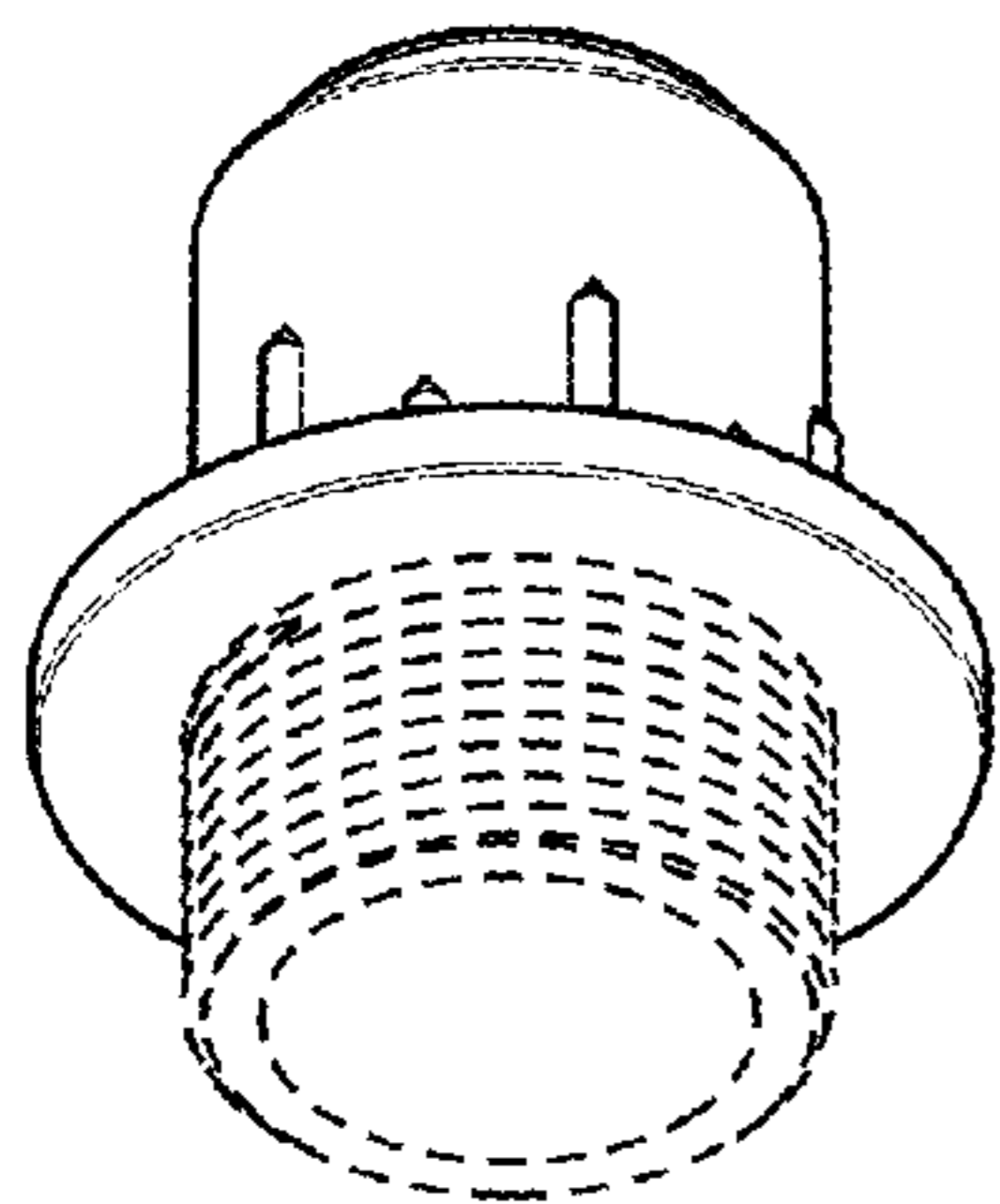

FIG. 3

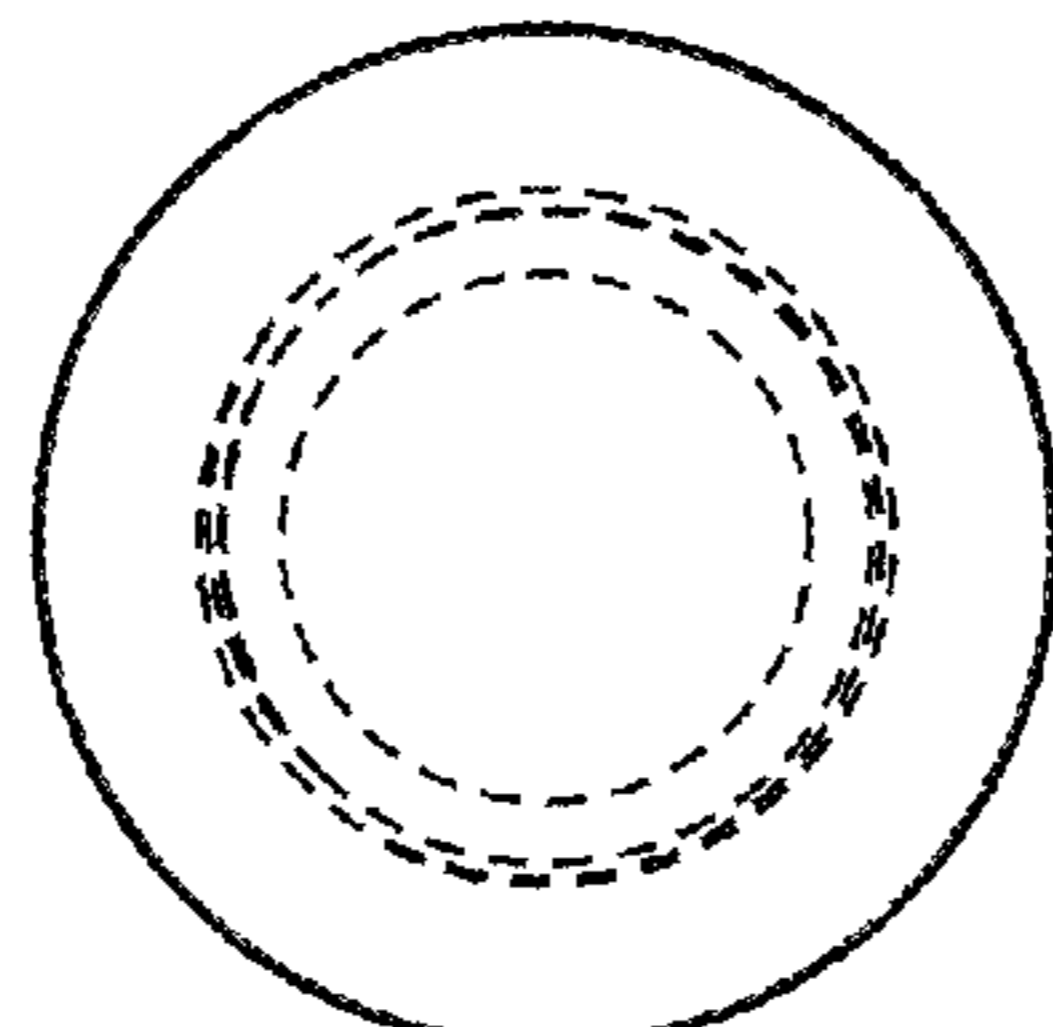

FIG. 6

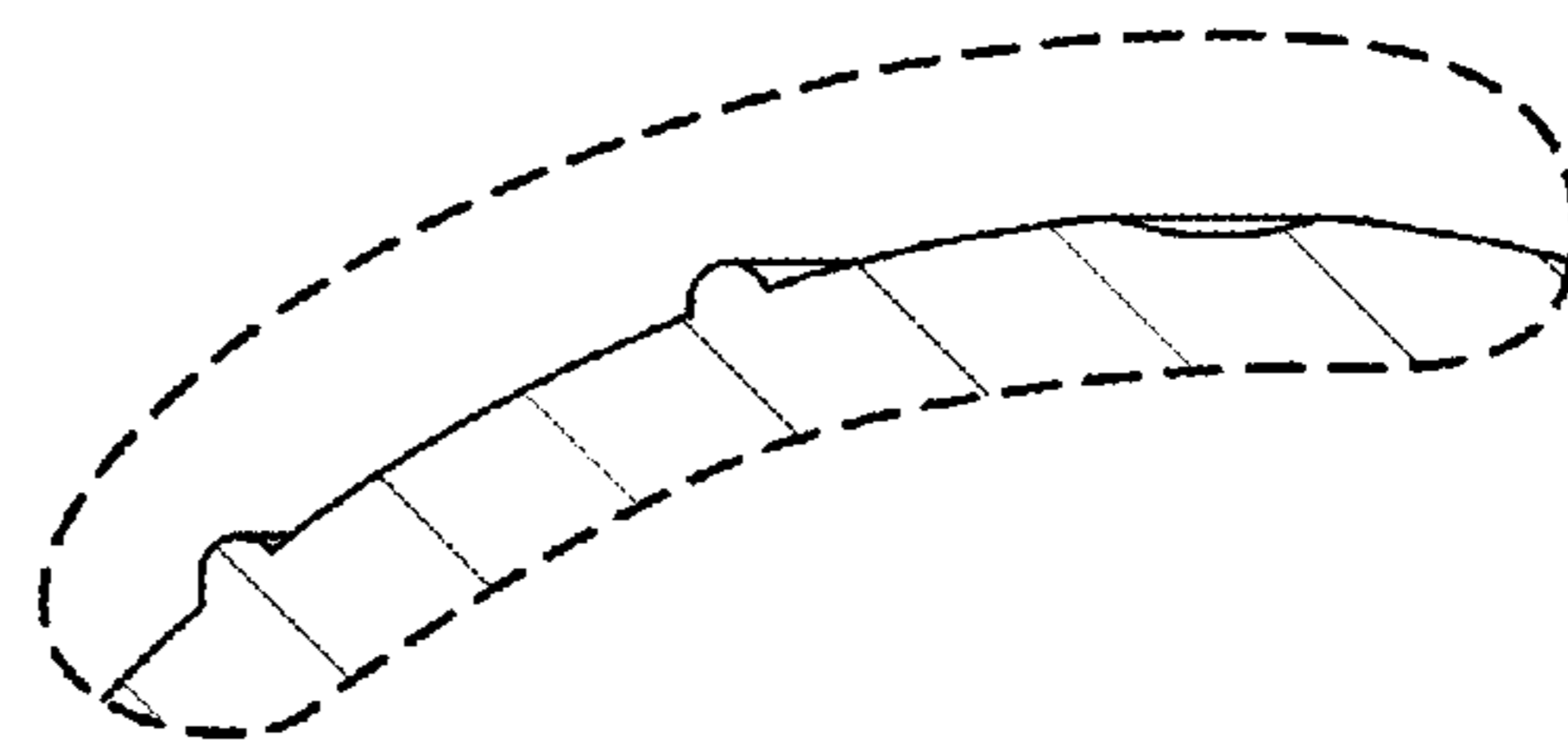

FIG. 9