



US00D791221S

(12) **United States Design Patent**
Slaton

(10) **Patent No.:** **US D791,221 S**

(45) **Date of Patent:** **** Jul. 4, 2017**

(54) **GUITAR TUNER**

(71) Applicant: **Guitar Center, Inc.**, Westlake Village,
CA (US)

(72) Inventor: **Robin Richard Slaton**, Fort Collins,
CO (US)

(73) Assignee: **Guitar Center, Inc.**, Westlake Village,
CA (US)

(**) Term: **15 Years**

(21) Appl. No.: **29/545,153**

(22) Filed: **Nov. 10, 2015**

(51) **LOC (10) Cl.** **17-03**

(52) **U.S. Cl.**
USPC **D17/20**

(58) **Field of Classification Search**
USPC D17/20, 21, 99; D9/643, 738, 781;
D8/105, 306, 310, 323, 352, 382, 392,
(Continued)

(56) **References Cited**

U.S. PATENT DOCUMENTS

892,105 A * 6/1908 White F16L 3/202
122/510
3,059,948 A * 10/1962 Thompson F16C 11/106
384/170

(Continued)

OTHER PUBLICATIONS

Clay King, Potter Sponges at Discount Prices, no post date,
webarchive on Dec. 11, 2012, [online], [site visited on Sep. 19,
2016]. Available from Internet, <URL: <https://web.archive.org/web/20121211134548/http://www.clay-king.com/spongelist.htm>>.*

(Continued)

Primary Examiner — Sheryl Lane
Assistant Examiner — Samantha Wood

(74) *Attorney, Agent, or Firm* — Craig R. Miles; CR
MILES P.C.

(57) **CLAIM**

I claim the ornamental design for a guitar tuner, as shown
and described.

DESCRIPTION

FIG. 1 is a front and right side perspective view of a guitar
tuner, embodying our new design;
FIG. 2 is a front elevation view thereof;
FIG. 3 is a rear elevation view thereof;
FIG. 4 is a right side elevation view thereof;
FIG. 5 is a left side elevation view thereof;
FIG. 6 is a top plan view thereof;
FIG. 7 is a bottom plan view thereof;
FIG. 8 is a front and right side perspective view thereof,
whereby the guitar tuner is pivotally coupled to and out-
wardly extending from a first mounting element;
FIG. 9 is a front and right side perspective view thereof,
whereby the guitar tuner is pivotally coupled to and nested
within the first mounting element;
FIG. 10 is a front elevation view thereof, whereby the guitar
tuner is pivotally coupled to and nested within the first
mounting element;
FIG. 11 is a rear elevation view thereof, whereby the guitar
tuner is pivotally coupled to and nested within the first
mounting element;
FIG. 12 is a right side elevation view thereof, whereby the
guitar tuner is pivotally coupled to and nested within the first
mounting element;
FIG. 13 is a left side elevation view thereof, whereby the
guitar tuner is pivotally coupled to and nested within the first
mounting element;
FIG. 14 is a top plan view thereof, whereby the guitar tuner
is pivotally coupled to and nested within the first mounting
element;
FIG. 15 is a bottom plan view thereof, whereby the guitar
tuner is pivotally coupled to and nested within the first
mounting element;
FIG. 16 is a front and right side perspective view thereof,
whereby the guitar tuner is pivotally coupled to a second
mounting element;

(Continued)

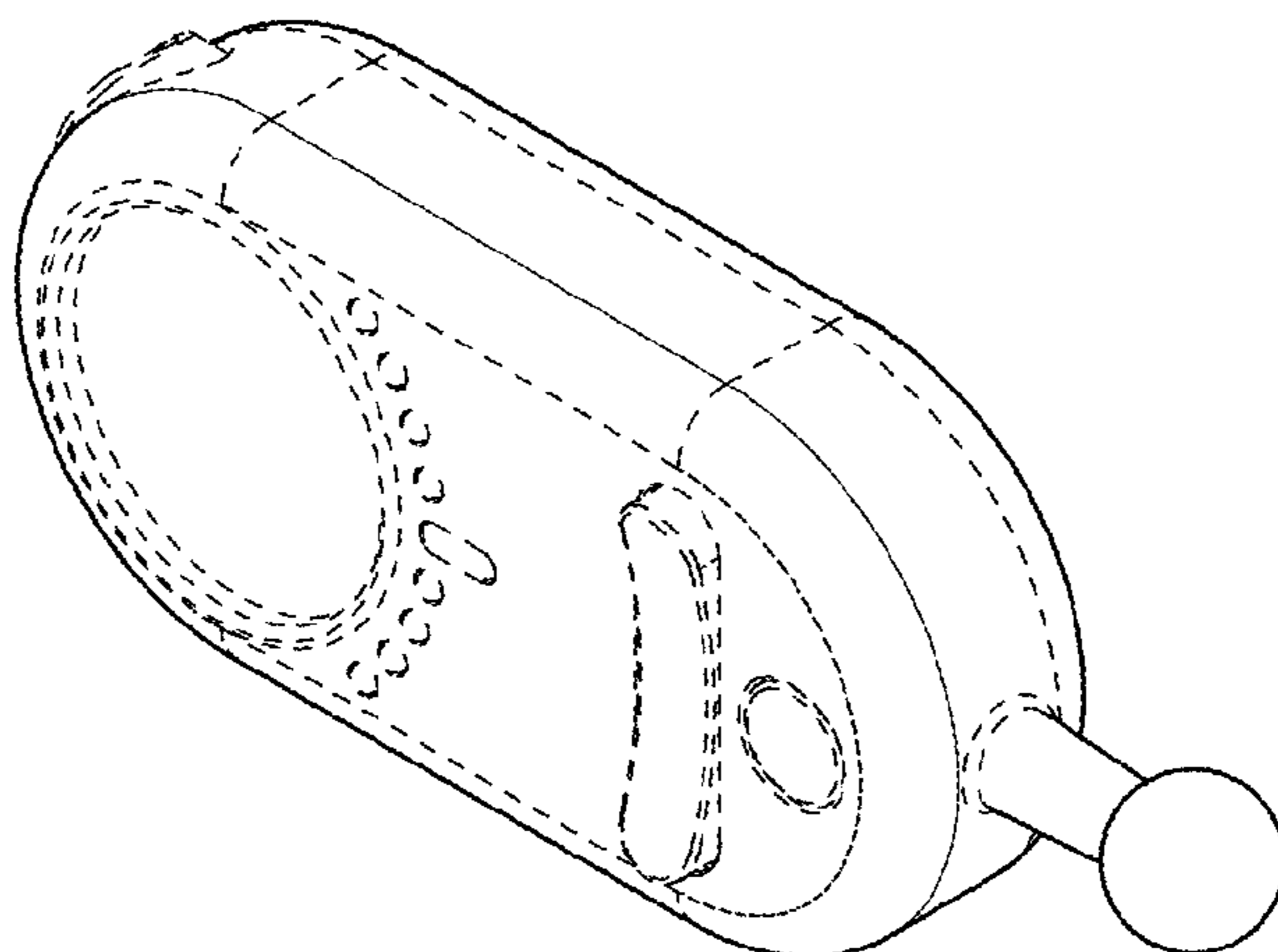

FIG. 17 is a front elevation view thereof, whereby the guitar tuner is pivotally coupled to the second mounting element; FIG. 18 is a rear elevation view thereof, whereby the guitar tuner is pivotally coupled to the second mounting element; FIG. 19 is a right side elevation view thereof, whereby the guitar tuner is pivotally coupled to the second mounting element; FIG. 20 is a left side elevation view thereof, whereby the guitar tuner is pivotally coupled to the second mounting element; FIG. 21 is a top plan view thereof, whereby the guitar tuner is pivotally coupled to the second mounting element; and, FIG. 22 is a bottom plan view thereof, whereby the guitar tuner is pivotally coupled to the second mounting element. The broken lines shown are included for the purpose of illustrating the unclaimed portions of the article and form no part of the claim.

1 Claim, 9 Drawing Sheets

(58) **Field of Classification Search**

USPC D8/394, 396; D14/188, 191, 217, 218, D14/230, 238, 265, 299, 474, 483, 496
 CPC B65D 73/00; B65D 25/205; B65D 43/164; B65D 81/3453; A45C 11/20; G10D 3/14; G10D 13/00; G10D 13/026; G10H 1/0066; G10H 1/32; G10G 7/00; G10G 7/02; F16M 11/041; F16M 11/14
 See application file for complete search history.

(56) **References Cited**

U.S. PATENT DOCUMENTS

D319,250 S * 8/1991 Iinuma D10/46
 5,168,677 A * 12/1992 Pronsato A63F 9/1208
 52/81.1
 5,170,001 A * 12/1992 Amendola G10D 13/003
 84/422.4
 5,284,659 A * 2/1994 Cherukuri A23G 3/2061
 424/435
 D353,748 S * 12/1994 Ferris D3/276
 5,427,265 A * 6/1995 Cautereels A45C 11/20
 16/260

D378,683 S * 4/1997 Ridinger D10/102
 5,712,767 A * 1/1998 Koizumi H01L 23/04
 257/E23.17
 D392,555 S * 3/1998 Glickman D8/382
 D444,169 S * 6/2001 Behringer D14/217
 D483,281 S * 12/2003 Cobigo D10/104.1
 D489,704 S * 5/2004 Kim D14/188
 D496,345 S * 9/2004 Shively D14/188
 D519,489 S * 4/2006 Joseph D14/191
 D528,708 S * 9/2006 Eustace D30/149
 D548,728 S * 8/2007 Yoshiyama D14/218
 D550,512 S * 9/2007 Delsol D7/615
 D555,171 S * 11/2007 Dai D14/496
 D560,684 S * 1/2008 Skurdal D14/496
 D560,810 S * 1/2008 Hennessy D24/214
 D563,434 S * 3/2008 Dai D14/496
 D584,739 S * 1/2009 Ahlgren D14/496
 D650,268 S * 12/2011 Gibson D9/420
 D673,848 S * 1/2013 Bailey D9/428
 D674,688 S * 1/2013 Loftin D9/428
 D675,516 S * 2/2013 Horton D9/424
 D706,516 S * 6/2014 Caglia D1/105
 D709,935 S * 7/2014 Stevens D15/199
 D715,154 S * 10/2014 Kalyanpur D9/682
 D722,107 S * 2/2015 Magnusson D17/20
 D743,381 S * 11/2015 Pi D14/218
 D746,620 S * 1/2016 King D6/682
 D747,958 S * 1/2016 Hyakutake D8/382
 D748,408 S * 2/2016 Toumazou D6/544
 9,299,327 B1 * 3/2016 Steinberger G10D 3/18
 D762,003 S * 7/2016 Lomeli D27/163
 D777,241 S * 1/2017 Costa D16/245
 2005/0064917 A1 * 3/2005 Peng H04M 1/021
 455/575.1
 2007/0234880 A1 * 10/2007 Adams G10H 1/0066
 84/601
 2012/0266735 A1 * 10/2012 Dunlop F16M 11/041
 84/329

OTHER PUBLICATIONS

Fender, FCT-12 Clip-on Tuner, no post date, [online], [site visited on Apr. 19, 2017]. Available from Internet, <URL: <http://shop.fender.com/en-US/accessories/digital-tuners/fender-fct-12-color-clip-on-tuner/0239978100.html>>.*
 G Musik Shop, Jual Tuner Jepit Cherub WST-26, posted Jul. 5, 2014, [online], [site visited on Apr. 19, 2017]. Available from Internet, <URL: <http://gmusikshop.com/jual-tuner-jepit-cherub-wst-26/>>.*

* cited by examiner

FIG. 1

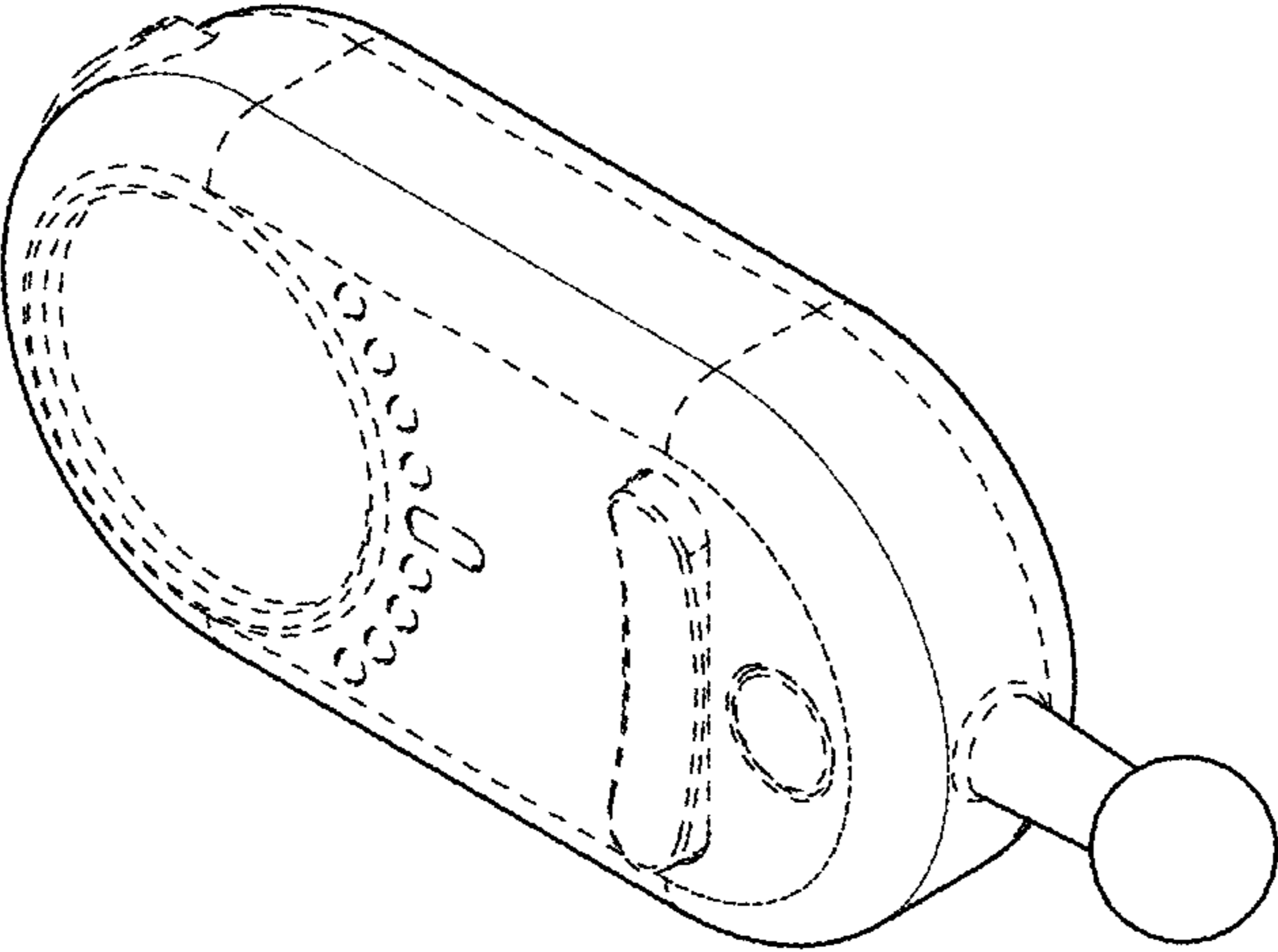

FIG. 2

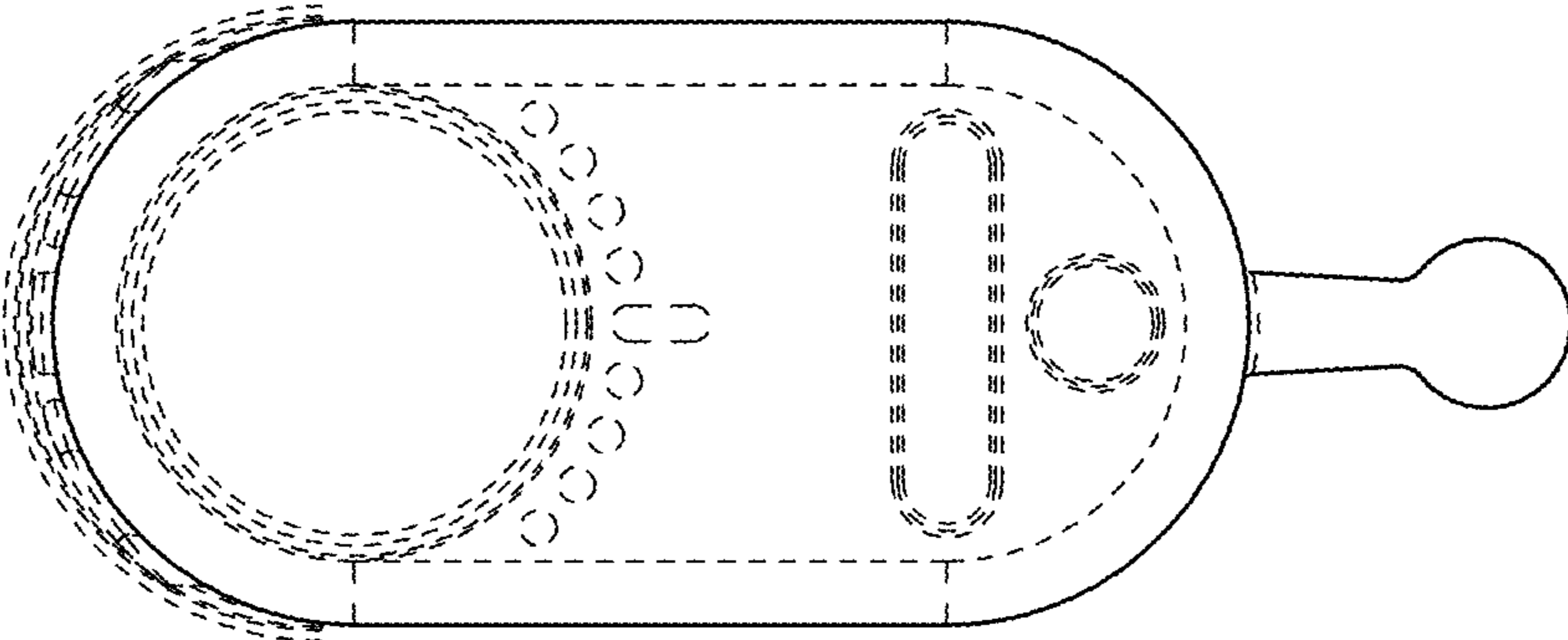

FIG. 3

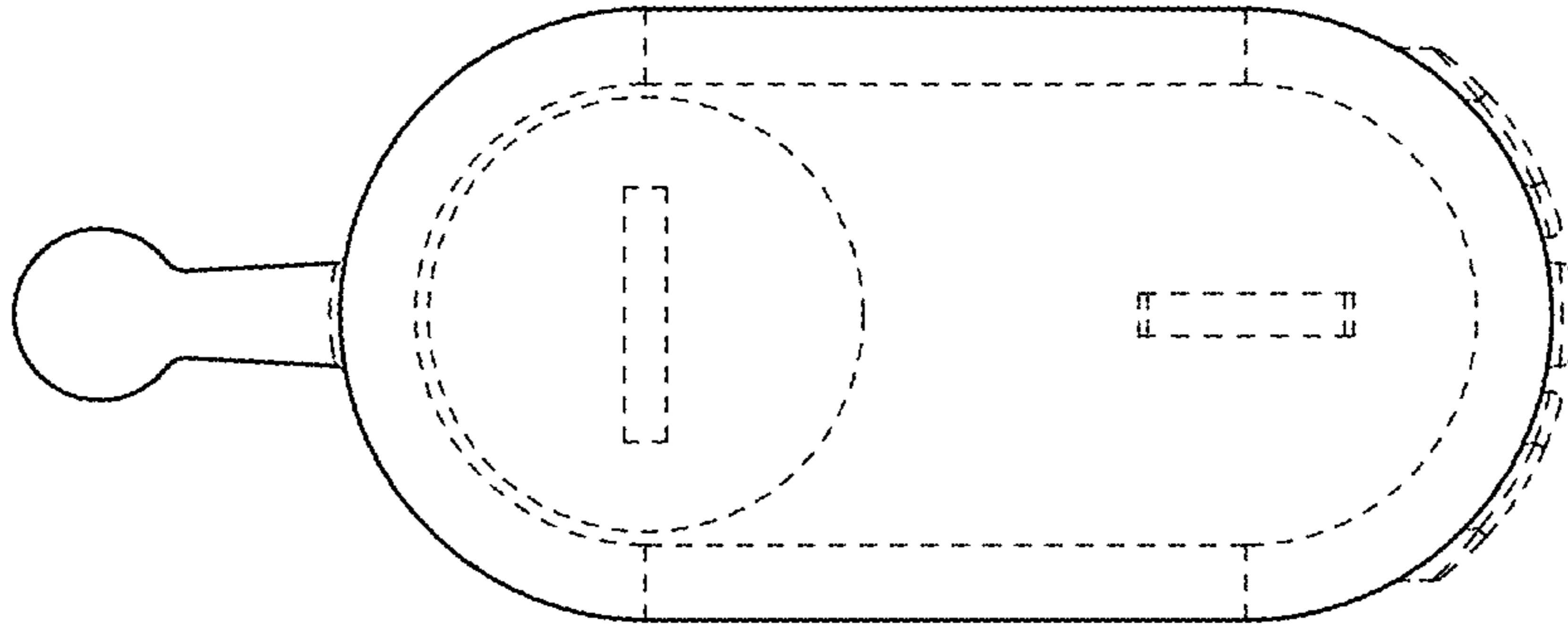

FIG. 4

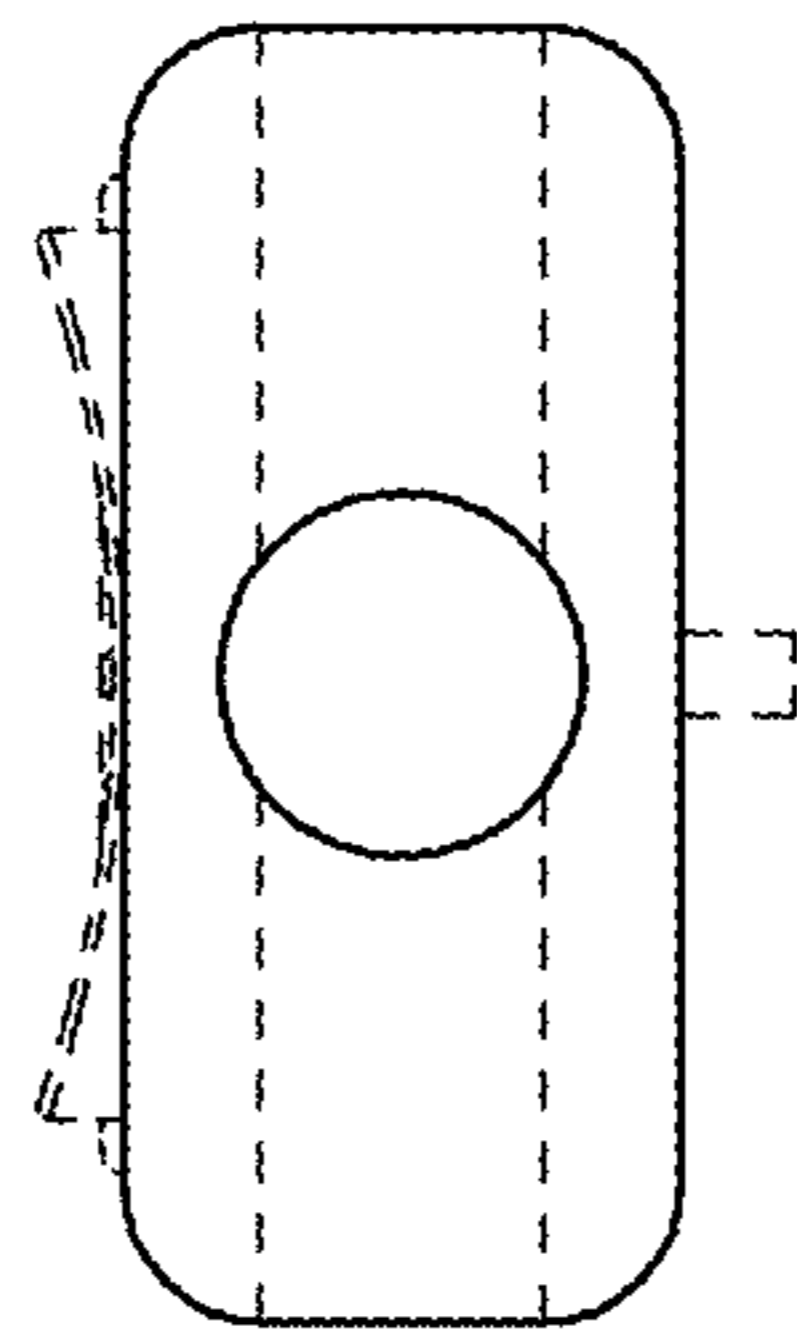

FIG. 5

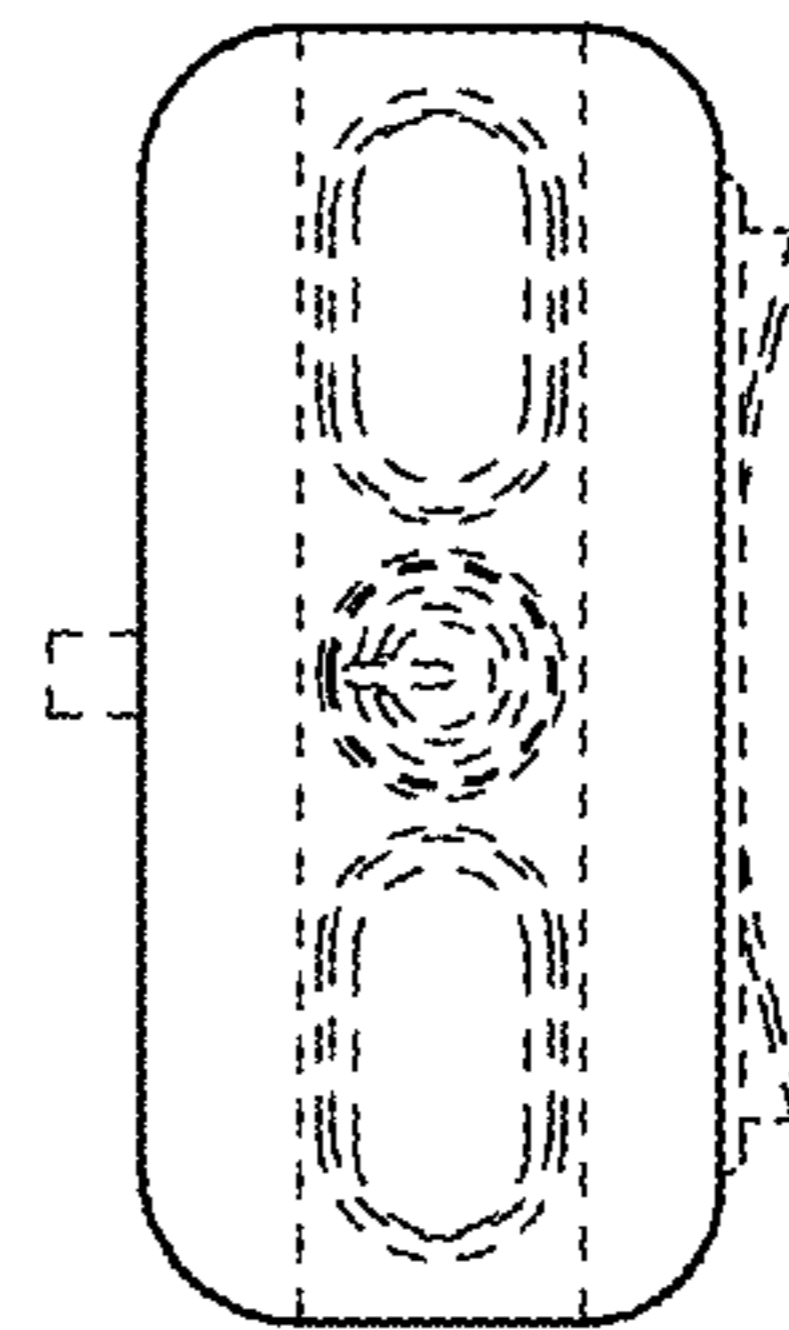

FIG. 6

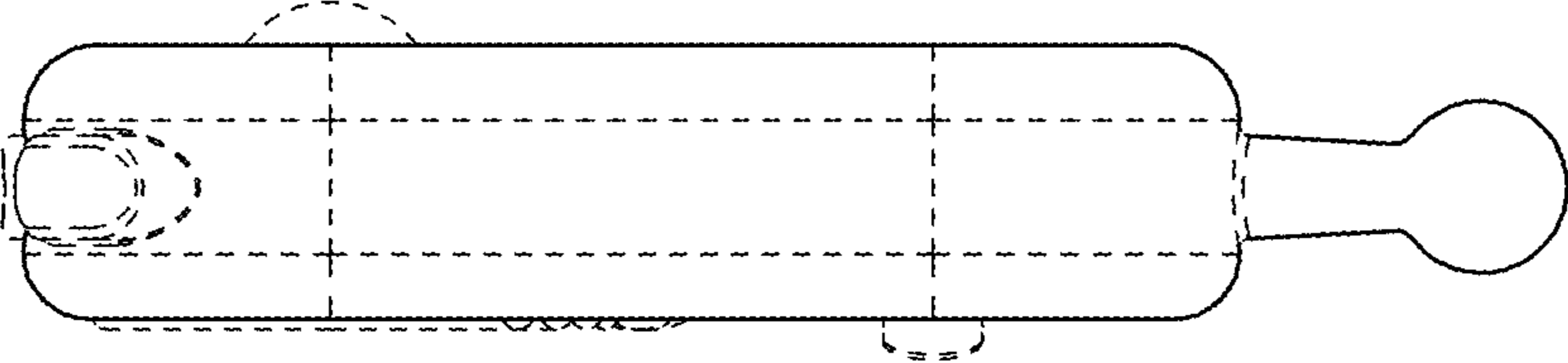

FIG. 7

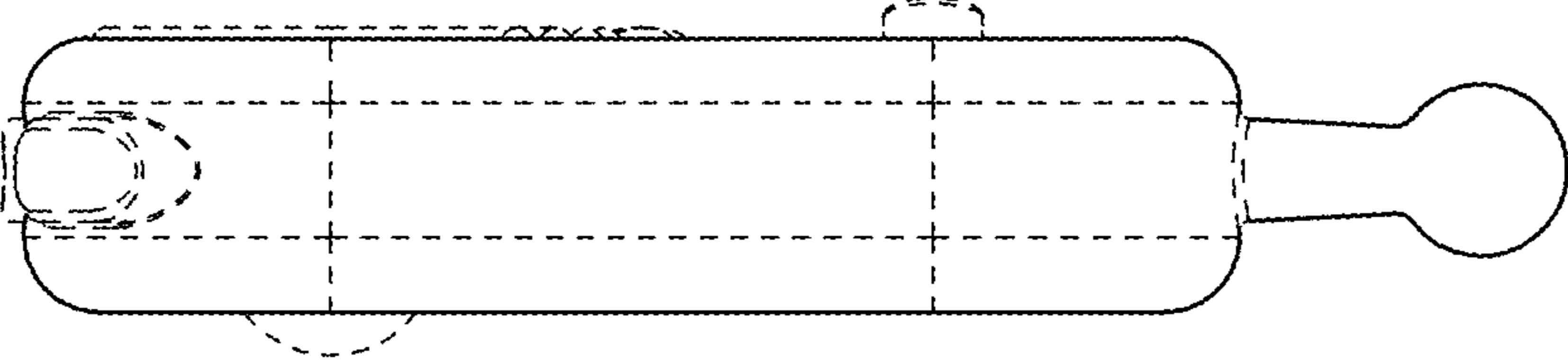

FIG. 8

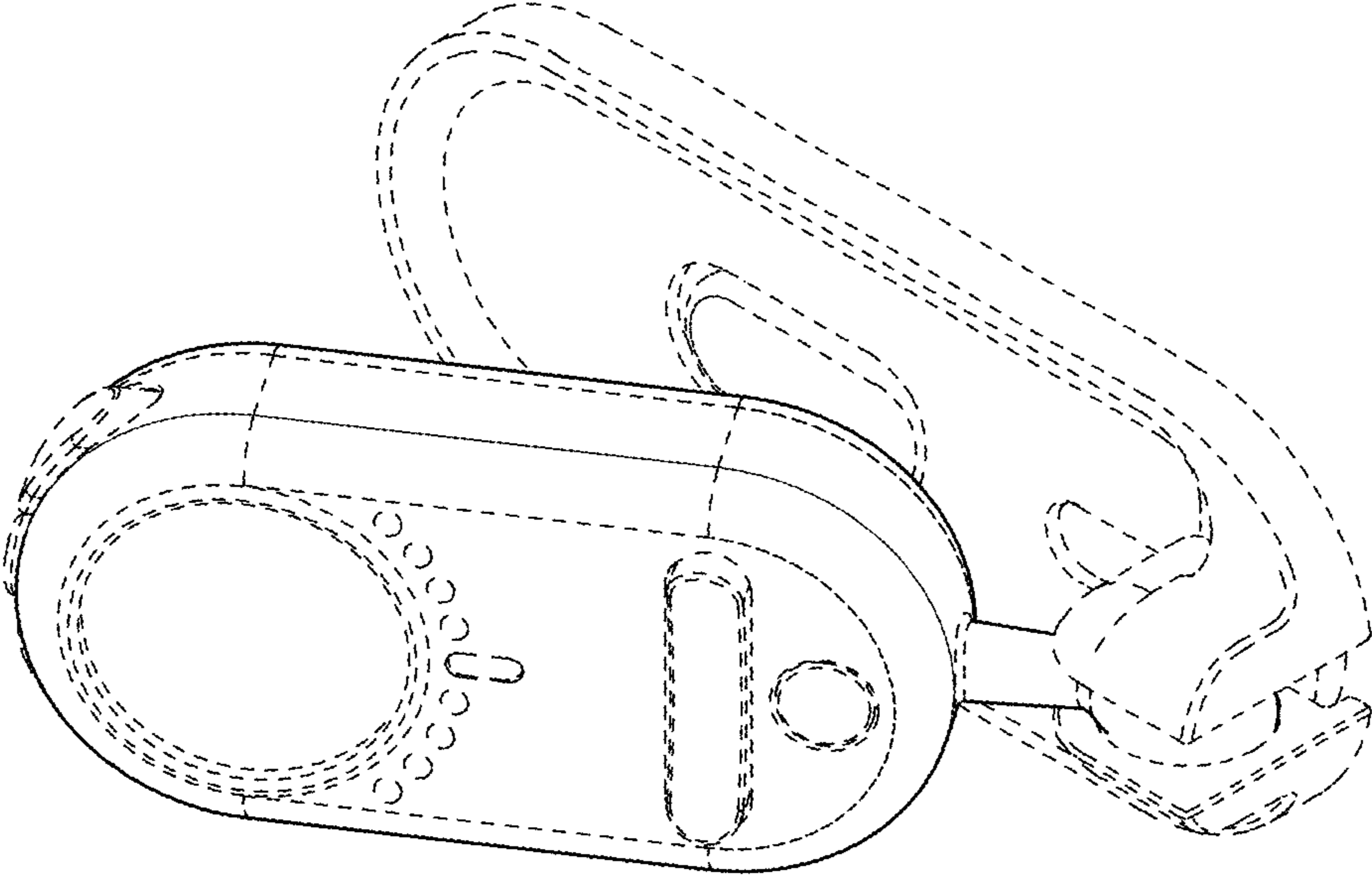

FIG. 9

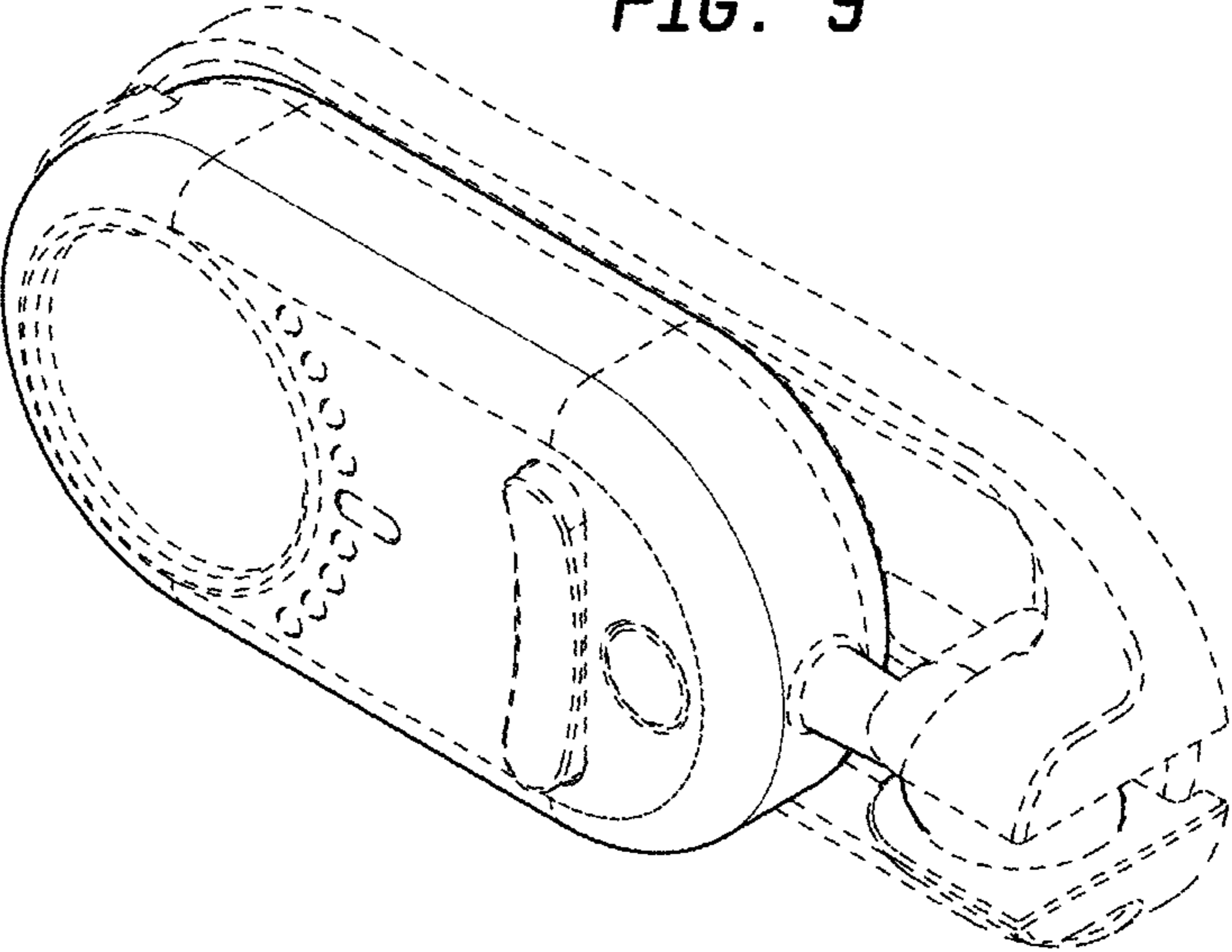

FIG. 10

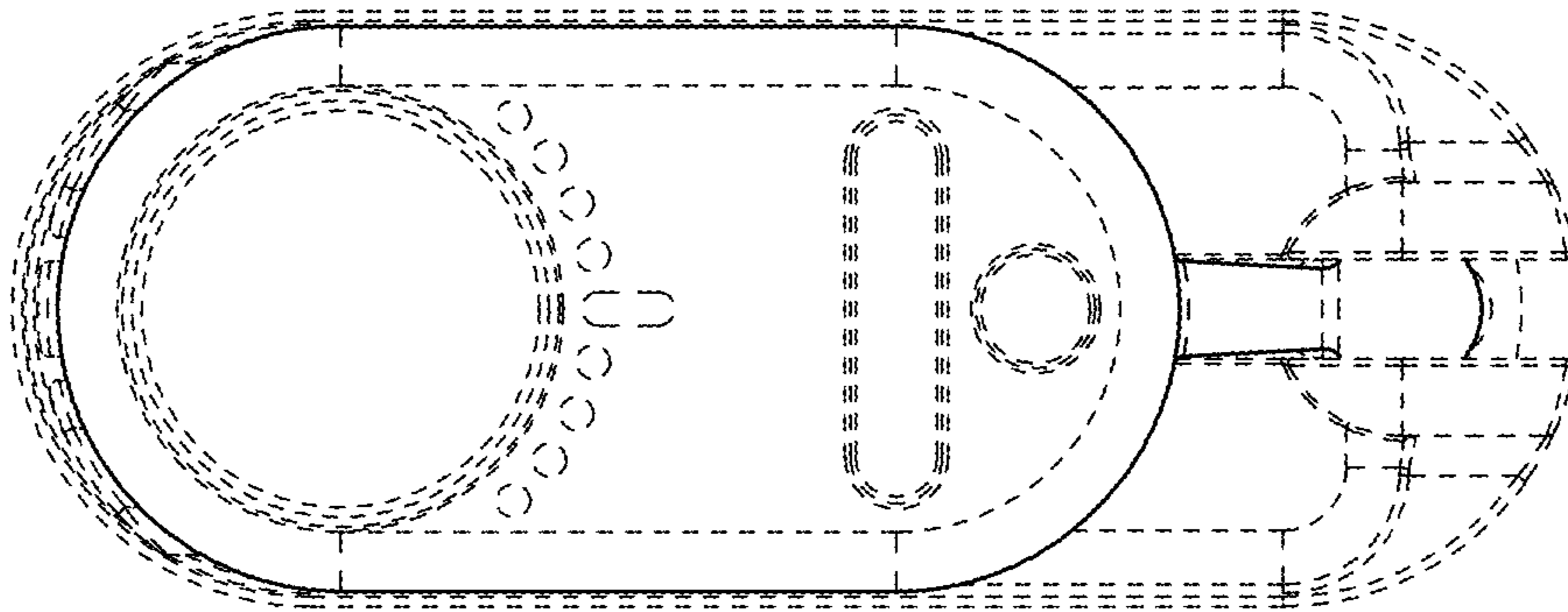

FIG. 11



FIG. 12

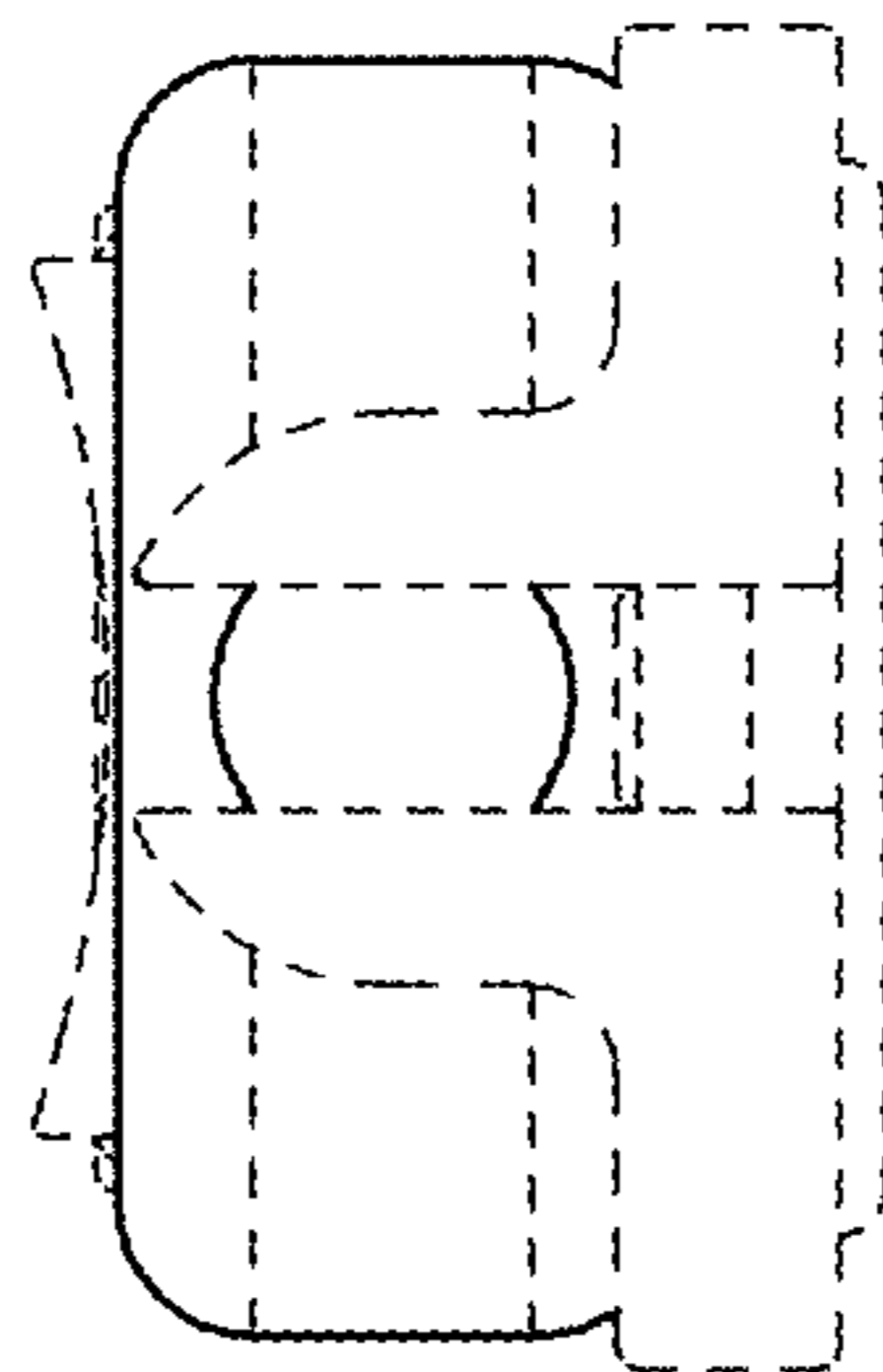

FIG. 13

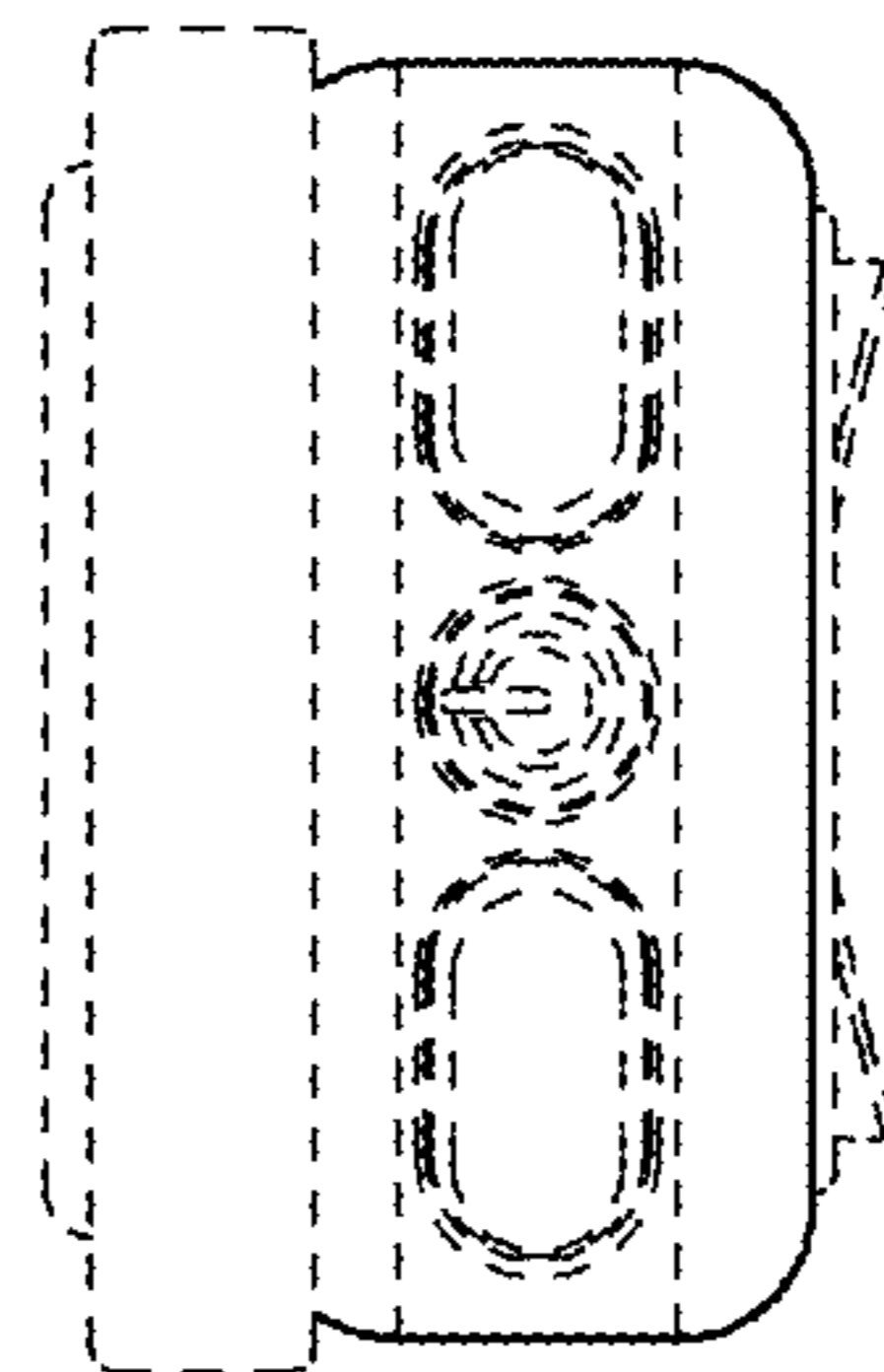

FIG. 14

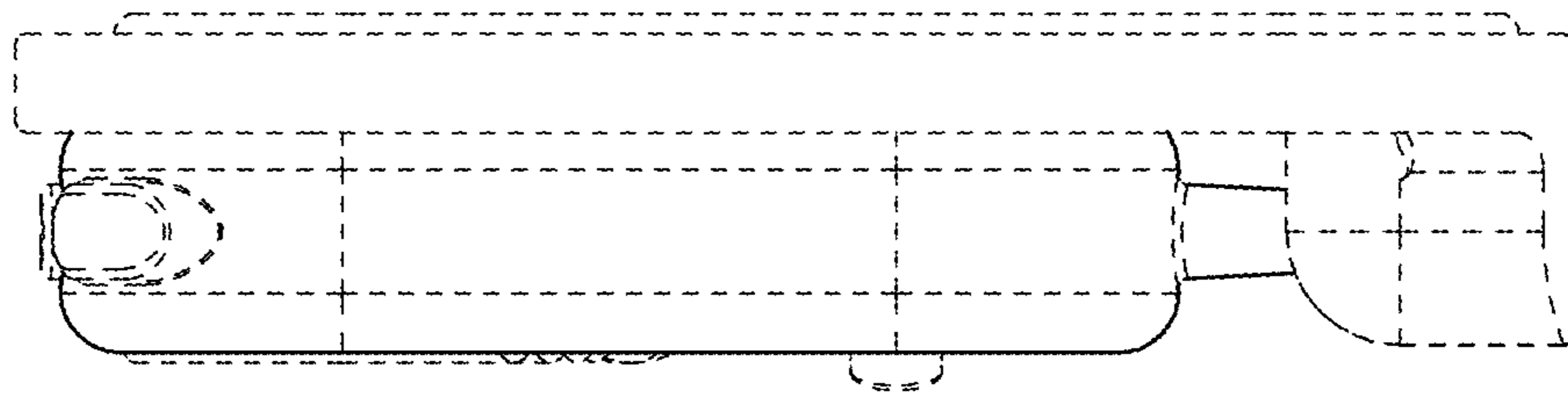

FIG. 15

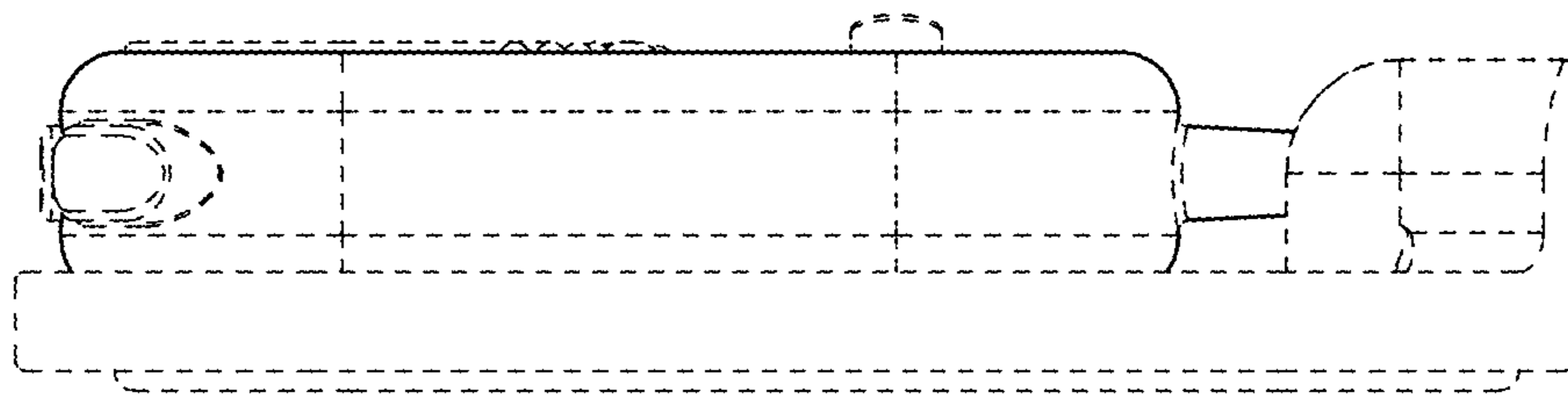

FIG. 16

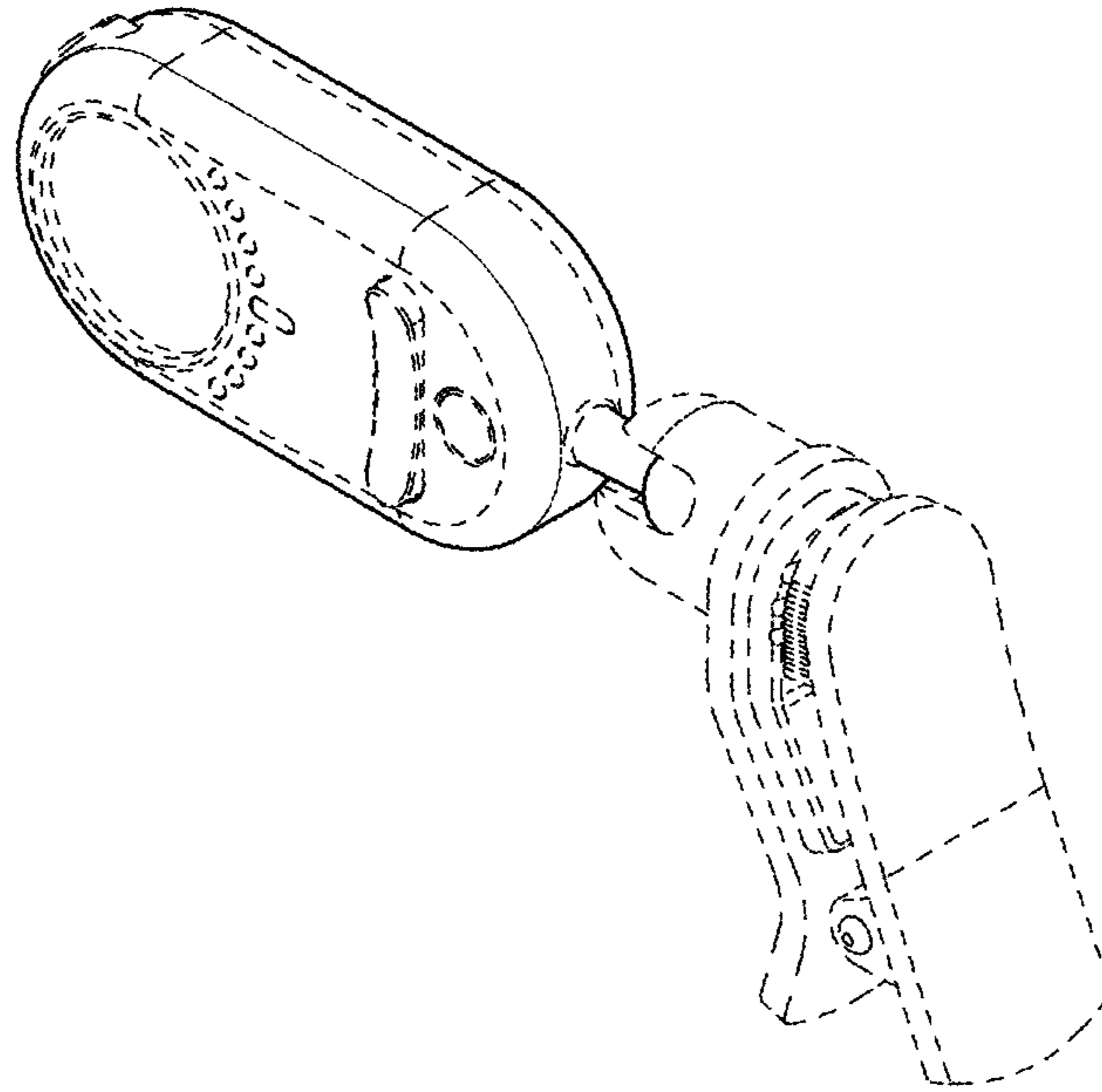

FIG. 17

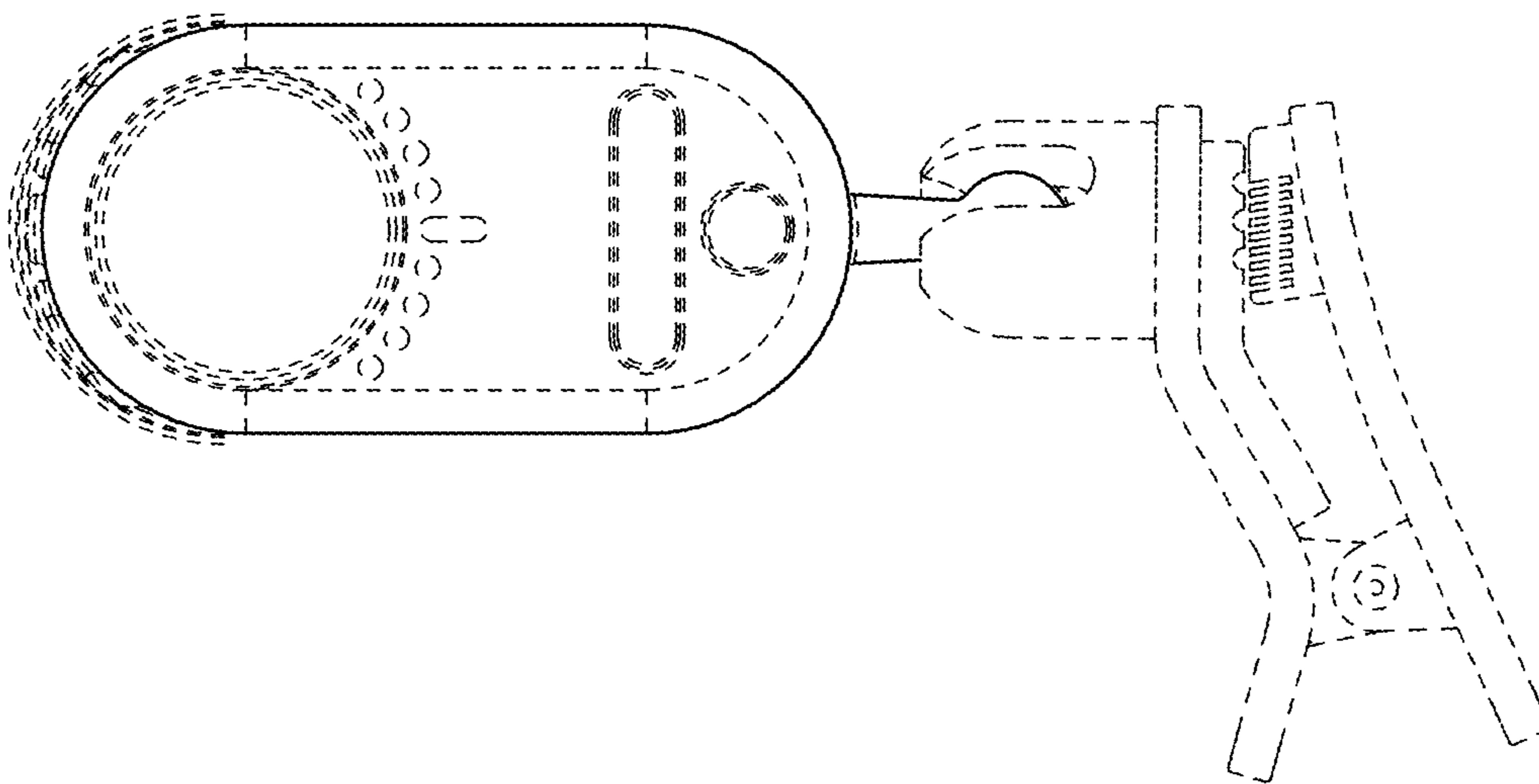

FIG. 18

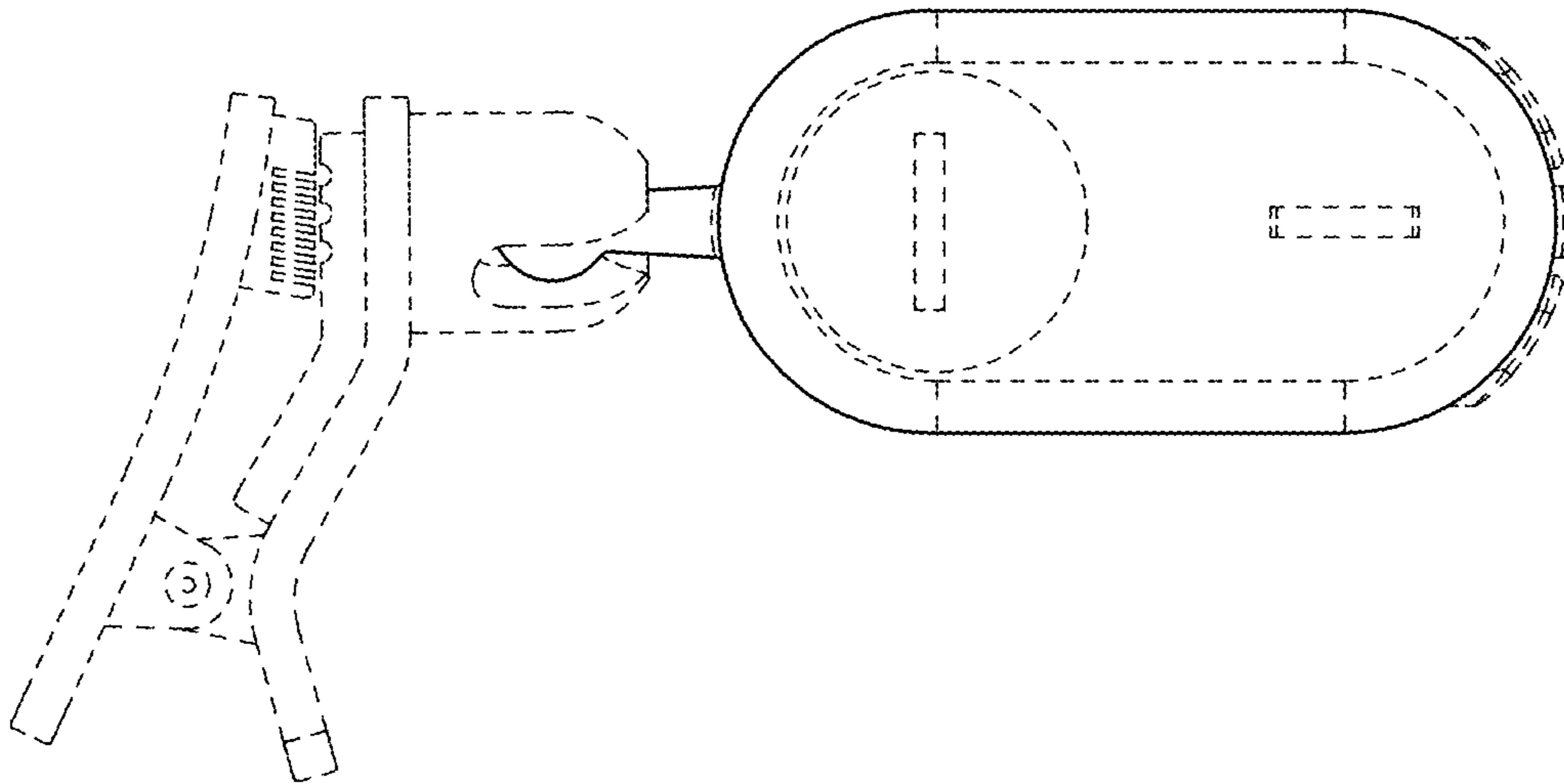

FIG. 19

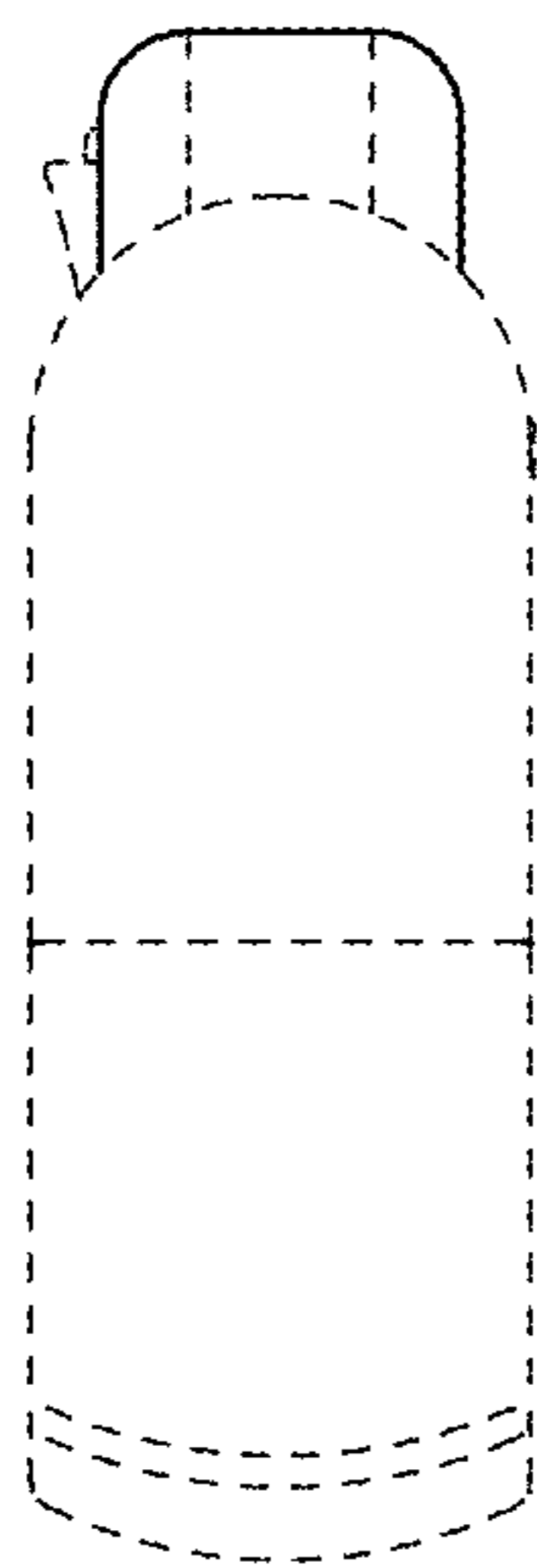

FIG. 20

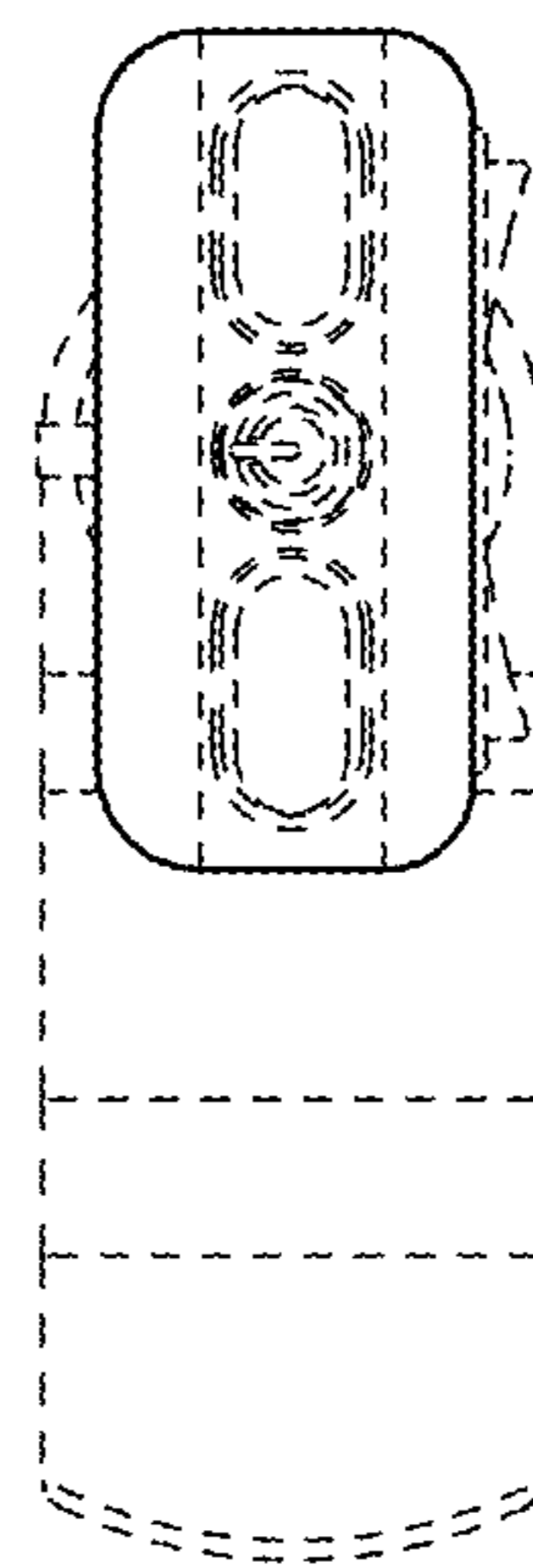

FIG. 21

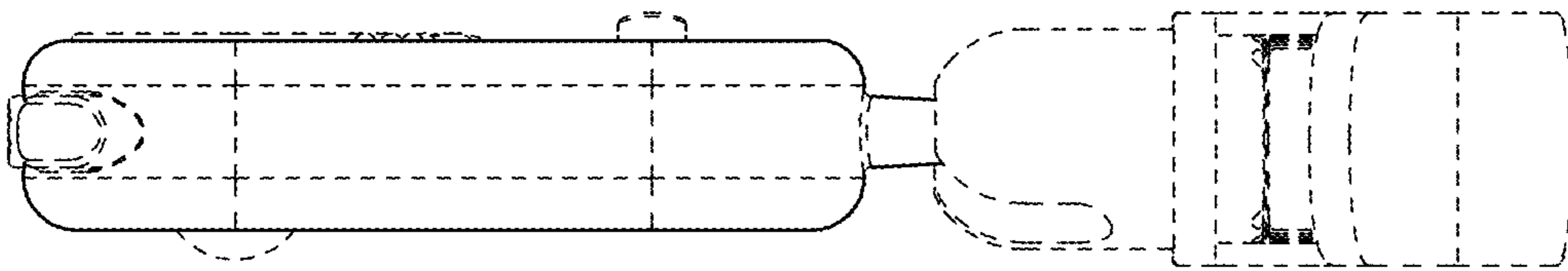

FIG. 22

