



US00D791109S

(12) **United States Design Patent** (10) **Patent No.:** **US D791,109 S**
Wallace et al. (45) **Date of Patent:** **** Jul. 4, 2017**

(54) **NAVIGATION SATELLITE SYSTEM ANTENNA**

5,740,048 A 4/1998 Abel et al.
D401,288 S * 11/1998 Dunipace D21/443
D401,592 S * 11/1998 Nishimura D14/230

(71) Applicant: **Trimble Navigation Limited**, Sunnyvale, CA (US)

(Continued)

(72) Inventors: **Gregory Craig Wallace**, Arvada, CO (US); **Michael Sanders**, Ilam (NZ); **Shawn D. Weisenburger**, Denver, CO (US)

FOREIGN PATENT DOCUMENTS

EP 0508405 10/1992
EP 2275778 A1 1/2011

(Continued)

(73) Assignee: **Trimble Inc.**, Sunnyvale, CA (US)

OTHER PUBLICATIONS

(**) Term: **15 Years**

“Timble Zephyr Geodetic Antenna,” [online], retrieved Jul. 27, 2016, retrieved from <<http://www.trimble.com/gnss-inertial/zephyr-geodetic-antennas.aspx?dtID=overview>>.*

(21) Appl. No.: **29/527,030**

(Continued)

(22) Filed: **May 14, 2015**

(51) **LOC (10) Cl.** **14-03**

(52) **U.S. Cl.**
USPC **D14/233**

(58) **Field of Classification Search**
USPC D14/203–238; D21/300–304, 324–325, D21/402–403, 443, 447, 471, 479, 487, D21/503
CPC H04B 7/0617; H04B 7/0634; H04B 13/00; H04B 1/001; H04M 1/026; H01Q 3/005; H01Q 3/34; G06F 1/18; H05K 1/00

See application file for complete search history.

Primary Examiner — Karen Kearney
Assistant Examiner — Debra Callahan

(74) *Attorney, Agent, or Firm* — Kilpatrick Townsend & Stockton LLP

(57) **CLAIM**

We claim the ornamental design for a navigation satellite system antenna, as shown and described.

DESCRIPTION

FIG. 1 is a top front perspective view of a navigation satellite system antenna showing our new design; FIG. 2 is a front elevational view thereof; FIG. 3 is a right elevational view thereof; FIG. 4 is a rear elevational view thereof; FIG. 5 is a left elevational view thereof; FIG. 6 is a top plan view thereof; and, FIG. 7 is a bottom plan view thereof.

The broken lines in the figures illustrate portions of the navigation satellite system antenna that form no part of the claimed design.

1 Claim, 4 Drawing Sheets

(56) **References Cited**

U.S. PATENT DOCUMENTS

D225,221 S * 11/1972 Sikorski D10/109.1
D227,785 S * 7/1973 Kaysen D14/233
D327,690 S * 7/1992 Ogawa D14/230
D361,569 S * 8/1995 Jarvis D14/230
D362,470 S * 9/1995 Smith D21/443
D363,935 S * 11/1995 McGreevy D14/230
5,471,217 A 11/1995 Hatch et al.
5,477,228 A 12/1995 Tiwari et al.
5,621,416 A 4/1997 Lennen
D379,992 S * 6/1997 Aldama D14/230

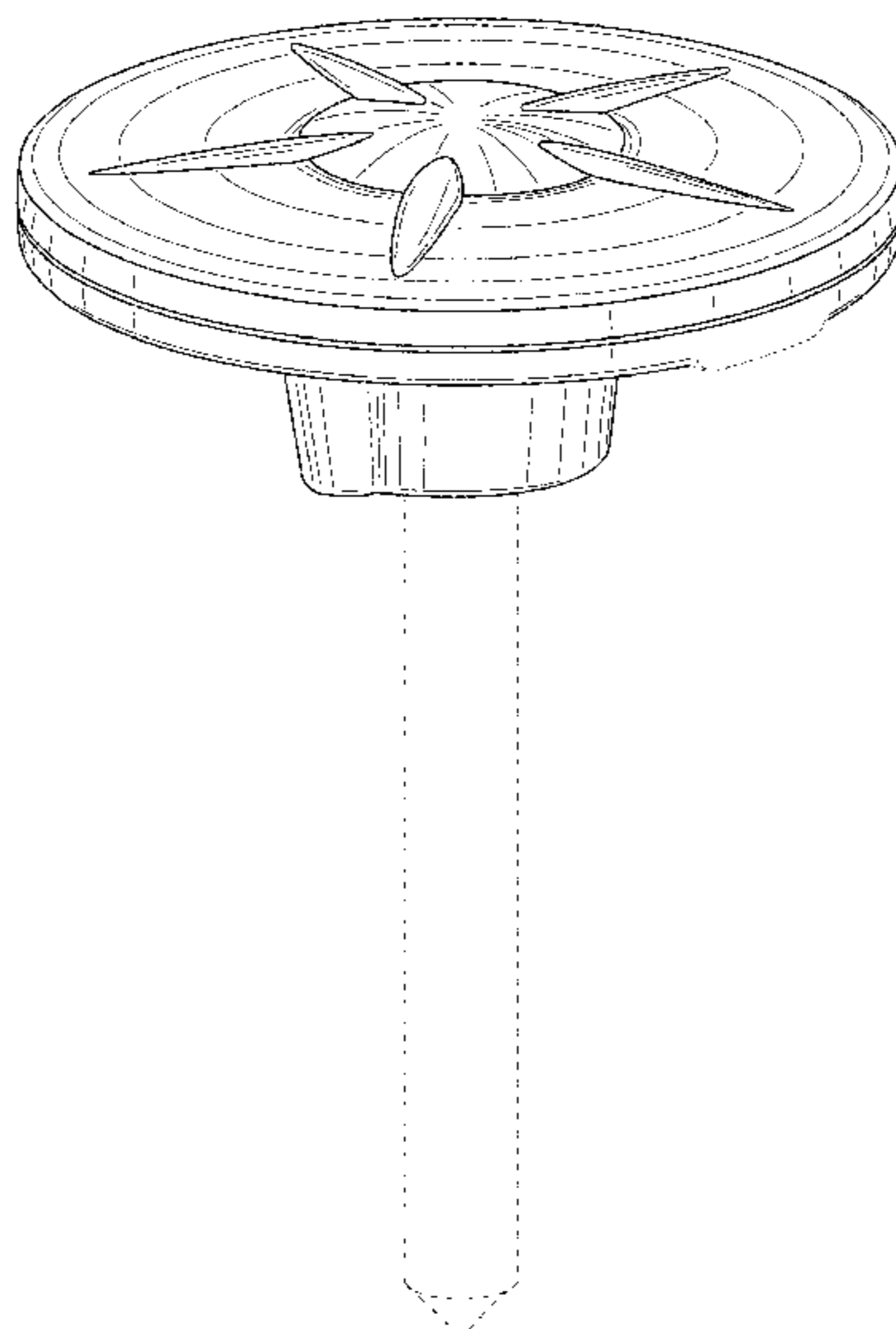

(56)

References Cited

U.S. PATENT DOCUMENTS

5,899,957 A 5/1999 Loomis
 5,913,170 A 6/1999 Wortham
 D421,439 S * 3/2000 Giuntoli D14/230
 D426,827 S * 6/2000 Tsai Wang D14/230
 D442,168 S * 5/2001 Warner D14/231
 6,249,245 B1 6/2001 Watters et al.
 6,324,473 B1 11/2001 Eschenbach
 6,408,178 B1 6/2002 Wickstrom et al.
 6,429,808 B1 8/2002 King et al.
 D467,242 S * 12/2002 Warner D14/230
 6,510,387 B2 1/2003 Fuchs et al.
 D471,539 S * 3/2003 Warner D14/231
 6,565,144 B1 5/2003 Crean
 6,590,525 B2 7/2003 Yule et al.
 6,853,909 B2 2/2005 Scherzinger
 7,151,489 B2 12/2006 Pande et al.
 D543,540 S * 5/2007 Westerling D14/230
 D557,260 S * 12/2007 Westerling D14/230
 7,480,511 B2 1/2009 O'Meagher
 7,541,974 B2 6/2009 Scherzinger
 7,570,204 B1 8/2009 McGraw et al.
 D613,275 S * 4/2010 Omori D14/230
 D631,873 S * 2/2011 Jin D14/231
 7,908,106 B2 3/2011 Cho et al.
 7,961,141 B2 6/2011 Dai et al.
 8,078,192 B2 12/2011 Wirola et al.
 8,134,497 B2 3/2012 Janky et al.
 8,136,545 B2 3/2012 Jablonski
 8,447,519 B2 5/2013 Basnayake et al.
 D695,725 S * 12/2013 Taeger D14/230
 D698,765 S * 2/2014 Bremaud D14/231
 8,699,409 B2 4/2014 Aryan et al.
 8,719,188 B2 5/2014 Kuhn et al.
 D718,389 S * 11/2014 Pilot D21/302
 D729,214 S * 5/2015 Beaudoin D14/230
 9,037,527 B2 5/2015 Kuhn et al.
 D744,986 S * 12/2015 Huerta D14/230
 D746,798 S * 1/2016 Grundy D14/230
 D750,602 S * 3/2016 Yang D14/230
 2001/0017599 A1 8/2001 Yule et al.
 2002/0072854 A1 6/2002 Fuchs et al.
 2003/0114984 A1 6/2003 Scherzinger
 2005/0064878 A1 3/2005 O'Meagher et al.
 2005/0104774 A1 5/2005 Pande et al.
 2006/0146136 A1 7/2006 Cho et al.
 2007/0139262 A1 6/2007 Scherzinger
 2008/0319664 A1 12/2008 Kremin et al.
 2009/0024325 A1 1/2009 Scherzinger
 2009/0083430 A1 3/2009 Edge et al.
 2009/0093959 A1 4/2009 Scherzinger et al.
 2009/0189804 A1 7/2009 Ashjaee et al.
 2009/0262016 A1 10/2009 Wirola et al.
 2010/0057359 A1 3/2010 Caballero et al.
 2010/0079333 A1 4/2010 Janky et al.
 2010/0141510 A1 6/2010 Dai et al.
 2010/0260150 A1 10/2010 Aryan et al.
 2011/0018761 A1 1/2011 Walley et al.
 2011/0163914 A1 7/2011 Seymour et al.
 2011/0187590 A1 8/2011 Leandro
 2011/0195687 A1 8/2011 Das et al.
 2011/0285587 A1 11/2011 Vollath et al.
 2012/0116676 A1 5/2012 Basnayake et al.
 2013/0027246 A1 1/2013 Hadeif
 2014/0081571 A1 3/2014 Briggs et al.
 2014/0184442 A1 7/2014 Large et al.
 2014/0187193 A1 7/2014 Rudow et al.
 2014/0240170 A1 8/2014 Rudow et al.
 2014/0253375 A1 9/2014 Rudow et al.
 2014/0292569 A1 10/2014 Wallace et al.
 2014/0292570 A1 10/2014 Wallace et al.
 2014/0375493 A1 12/2014 Weisenburger et al.
 2014/0378170 A1 12/2014 Rudow et al.
 2014/0378171 A1 12/2014 Rudow et al.

2015/0009067 A1 1/2015 Rudow et al.
 2015/0043012 A1 2/2015 Rudow et al.
 2015/0045058 A1 2/2015 Rudow et al.
 2015/0045059 A1 2/2015 Rudow et al.
 2015/0050907 A1 2/2015 Rudow et al.
 2015/0057028 A1 2/2015 Rudow et al.
 2015/0289097 A1 10/2015 Rudow et al.

FOREIGN PATENT DOCUMENTS

EP 2 722 647 A1 4/2014
 KR 101241171 B1 3/2013
 WO 2005/045458 5/2005
 WO 2009074654 A1 6/2009
 WO 2011120141 A1 10/2011

OTHER PUBLICATIONS

"UNAVCO resources: GNSS Station Monumentation," [online], posted Feb. 24, 2010, retrieved Jul. 27, 2016, retrieved from <<http://kb.unavco.org/kb/article.php?id=104>>.*
 "PCT/US2015/035328 International Search Report", Oct. 15, 2015, pp. 1-13.
 "PCT/US2015/035346 International Search Report", Oct. 13, 2015, pp. 1-12.
 AFZAL, "Design Methodology for a Dual Frequency Configurable GPS Receiver", Proceedings of the 23rd International Technical Meeting of the Satellite Division of the Institute of Navigation (ION GNSS 2010), Sep. 24, 2010, pp. 2892-2900.
 Guixens, et al., "System Aspects and Practical Results for Precise Car Navigation with Modern Civil Signals Using a Software Receiver", Proceedings of the 21st International Technical Meeting of the Satellite Division of the Institute of Navigation (ION GNSS 2008), Sep. 19, 2008, pp. 2280-2292.
 Haak, "A Multi-Purpose Software GNSS Receiver for Automotive Applications", Proceedings of the 23rd International Technical Meeting of the Satellite Division of the Institute of Navigation (ION GNSS 2010), Sep. 24, 2010, pp. 1869-1874.
 Ruegamer, et al., "A Flexible and Portable Multiband GNSS Front-end System", Proceedings of the 25th International Technical Meeting of the Satellite Division of the Institute of Navigation (ION GNSS 2012), Sep. 21, 2012, pp. 2378-2389.
 "Comparison of Photogrammetry Software", http://en.wikipedia.org/wiki/Comparison_of_photogrammetry_software, Jul. 8, 2015, 4 pages.
 "Photogrammetry", <http://en.wikipedia.org/wiki/Photogrammetry>, Jun. 25, 2015, 5 pages.
 "Pi Pelican Imaging: Life in 3D", <http://www.pelicanimaging.com>, 2015, 3 pages.
 Church, "Close Range Photogrammetry vs. 3D Scanning of Archeological Documentation", <http://ncptt.nps.gov/blog/close-range-photogrammetry-vs-3d-scanning-for-archaeological-documentation/>, Nov. 6, 2012, 10 pages.
 Grussenmeyer, et al., "A comparison of photogrammetry software packages for the documentation of buildings", http://halshs.archives-ouvertes.fr/docs/00/28/12/54PDF/grussenmeyer_alkhalil_FIG2000.PDF, May 21, 2008, 9 pages.
 Hatch, "The Synergism of GPS Code and Carrier Measurements", Proceedings of the Third International Geodetic Symposium on Satellite Doppler Positioning, 1982, 1213-1232.
 Landau, et al., "Virtual Reference Stations Versus Broadcast Solutions in Network RTK", GNSS 2003, Graz, Austria, Apr. 2003, 15 pages.
 Thipparthi, "Improving Positional Accuracy Using Carrier Smoothing Techniques in Inexpensive GPS Receivers", MSEE Thesis, New Mexico State University, Las Cruces, NM, Feb. 2004, 101 pages.
 International Search Report of the International Searching Authority for PCT Application No. PCT/US2015/052370 mailed Jan. 8, 2016, 6 pages.

* cited by examiner

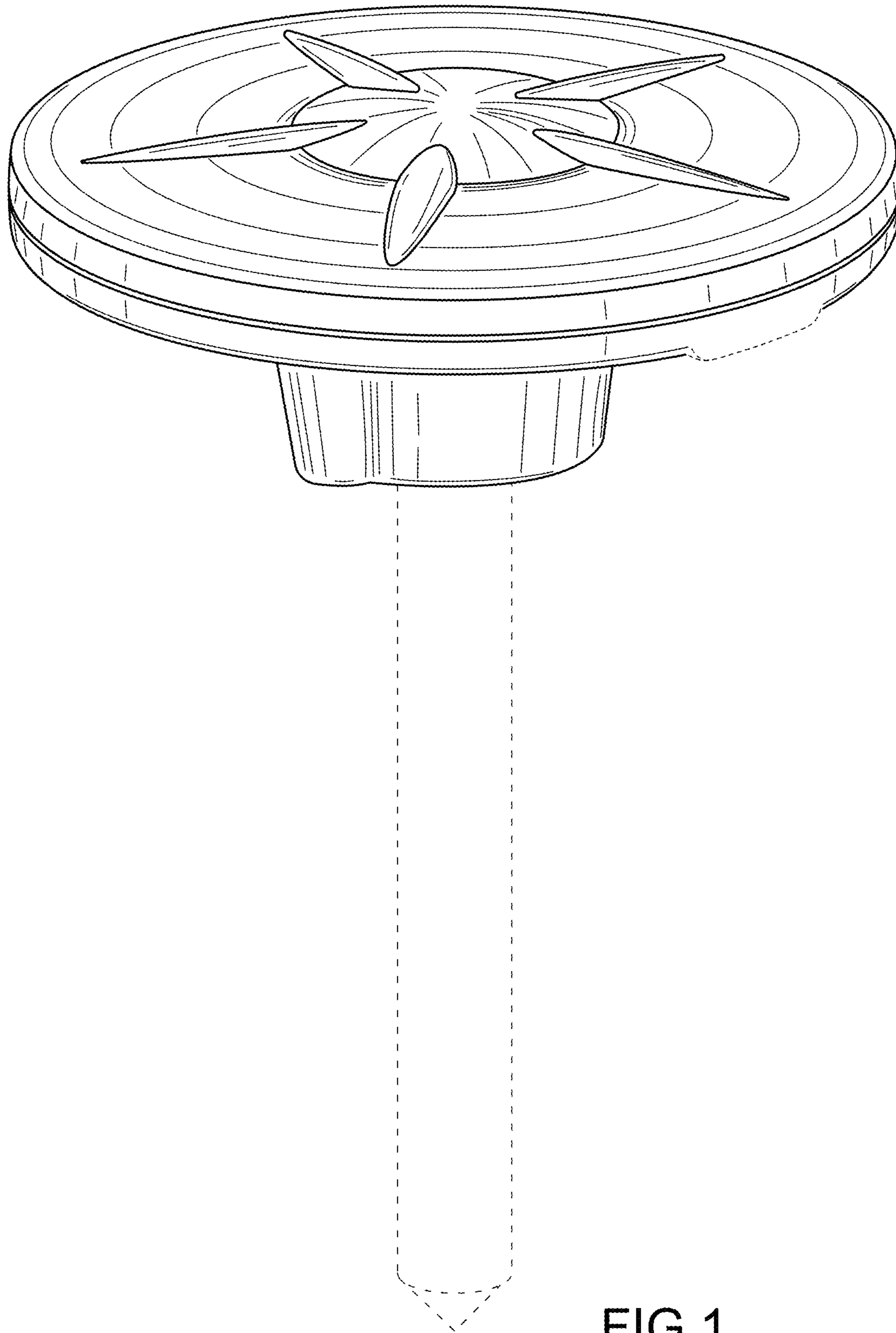

FIG. 1

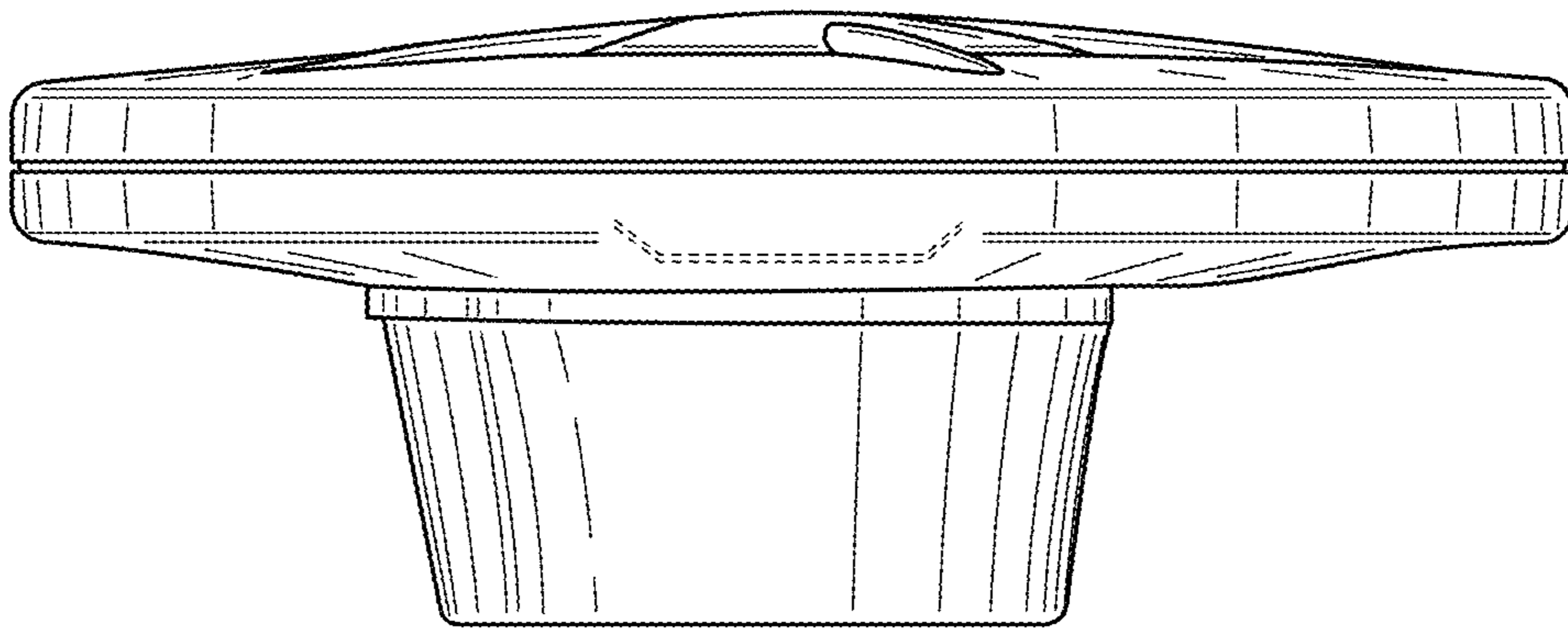

FIG. 2

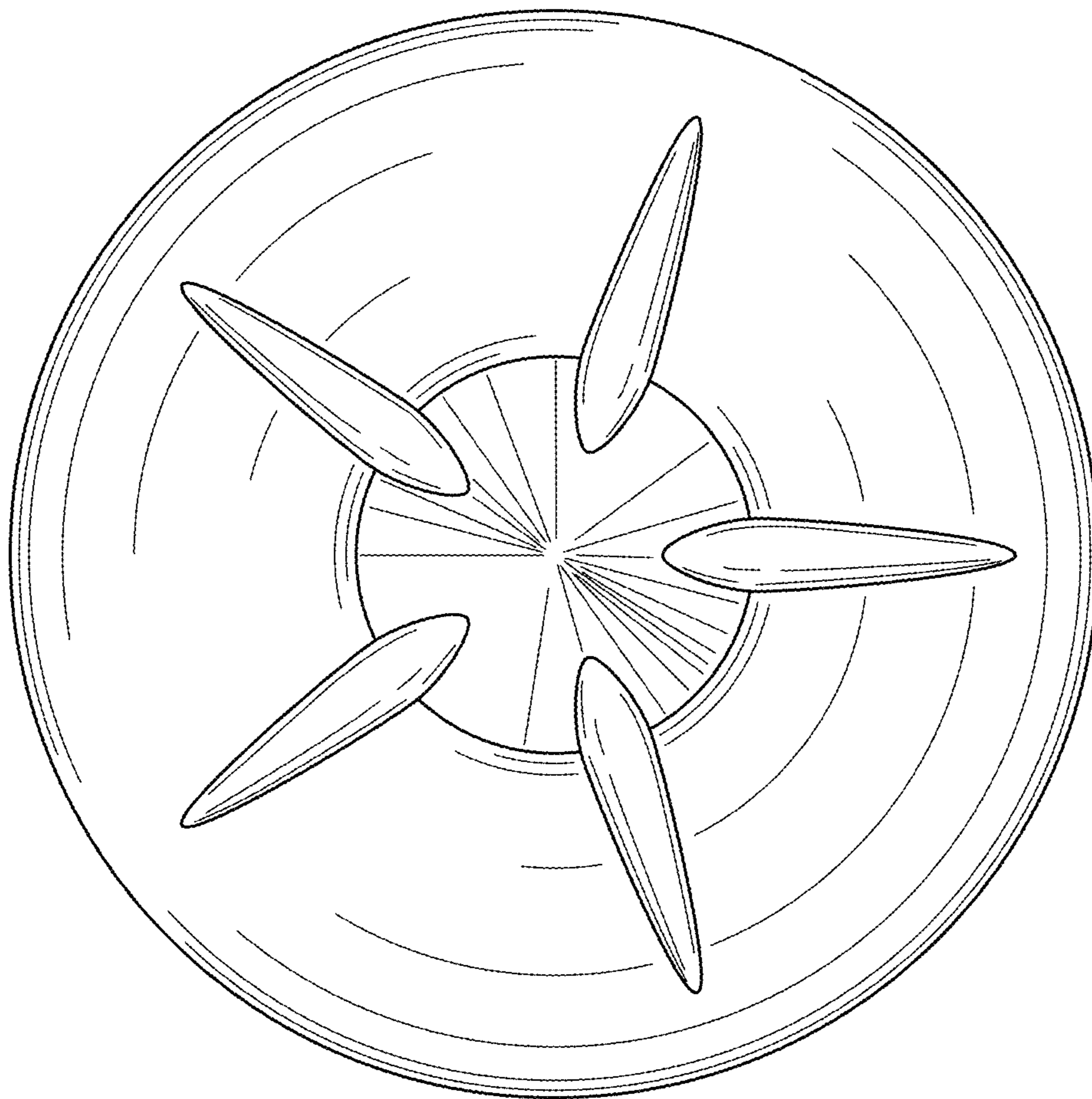

FIG. 6

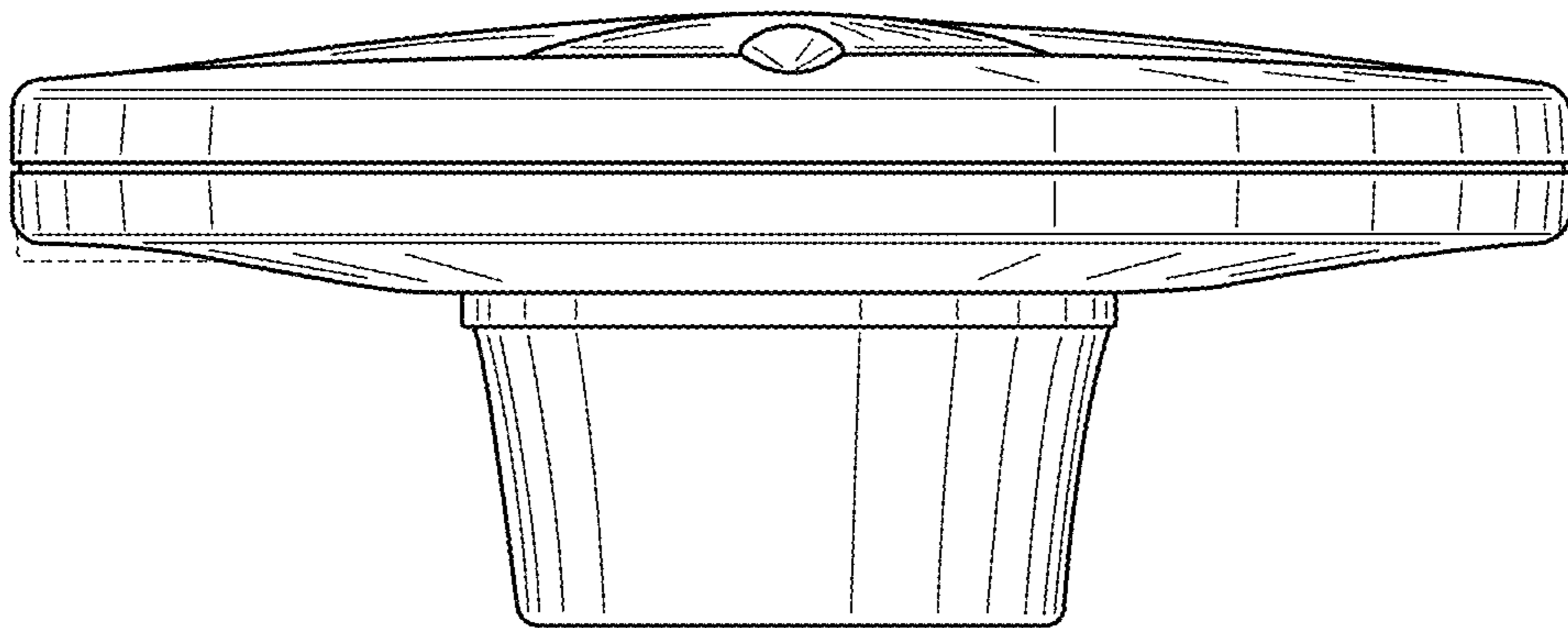

FIG. 3

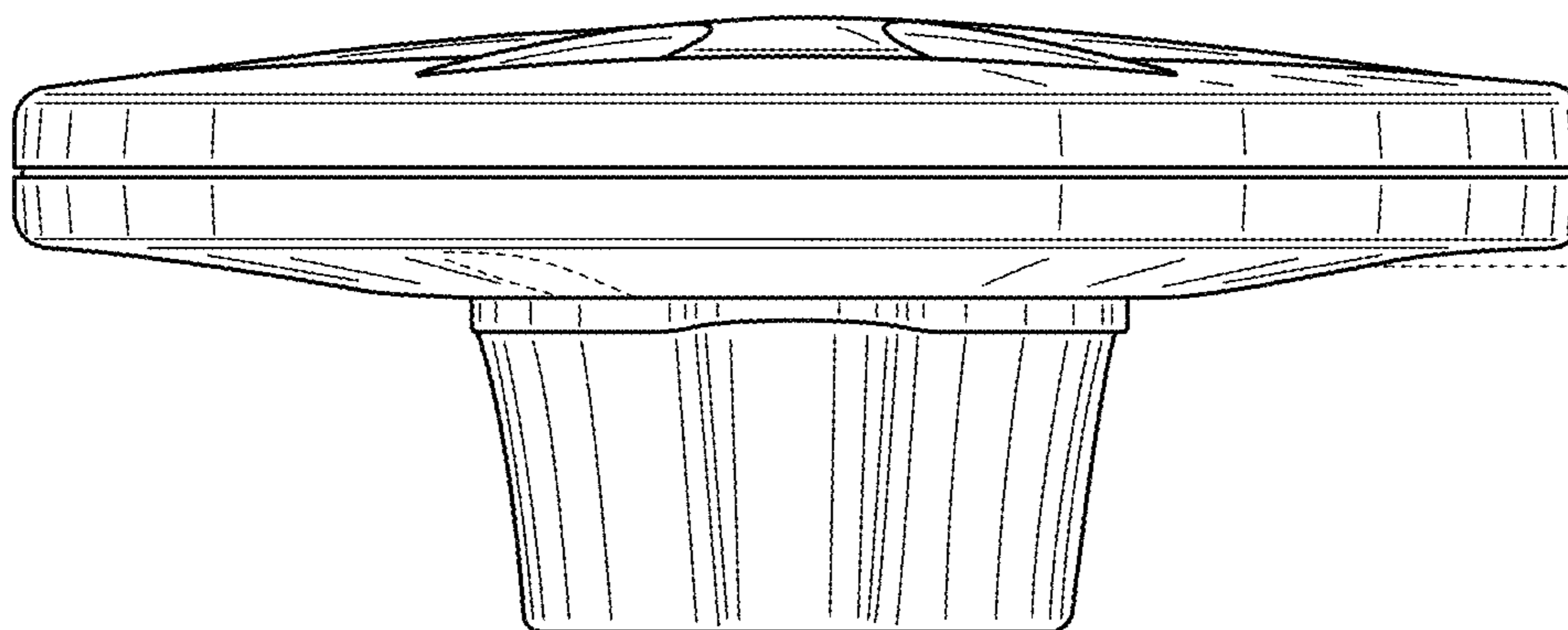

FIG. 5

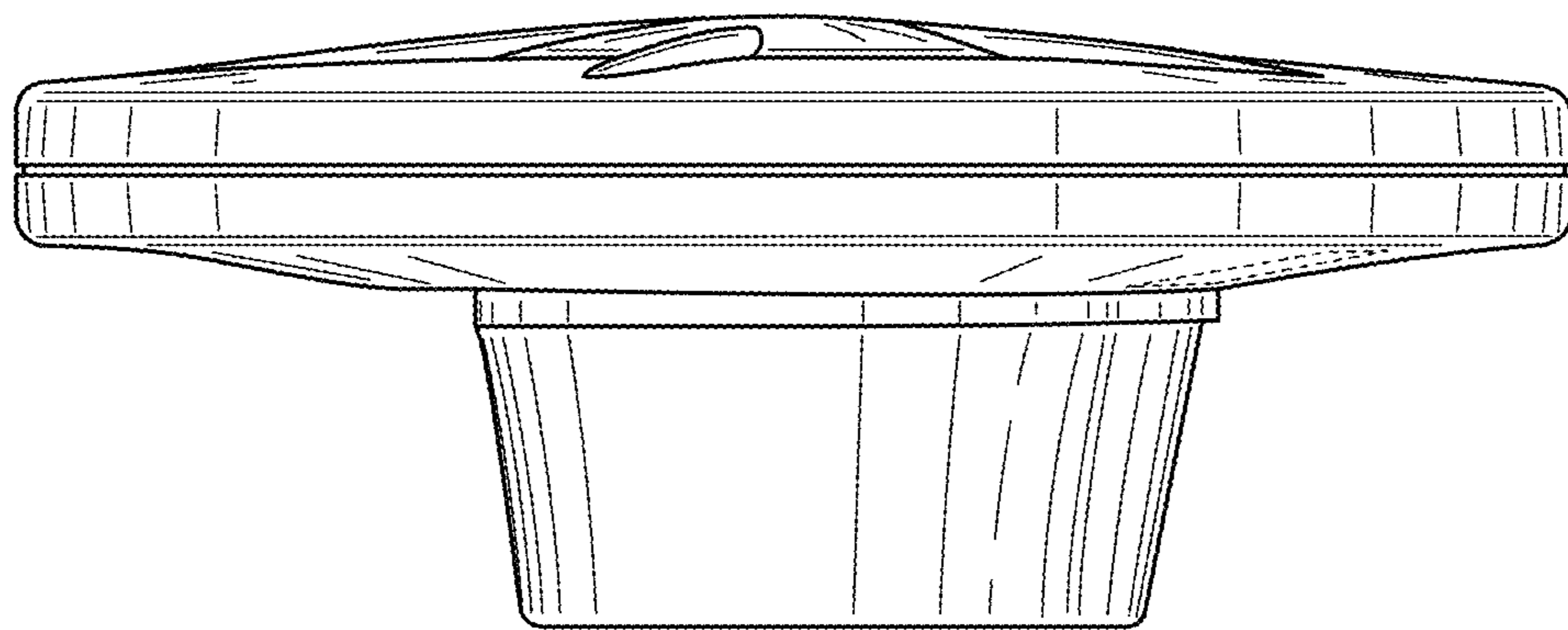

FIG. 4

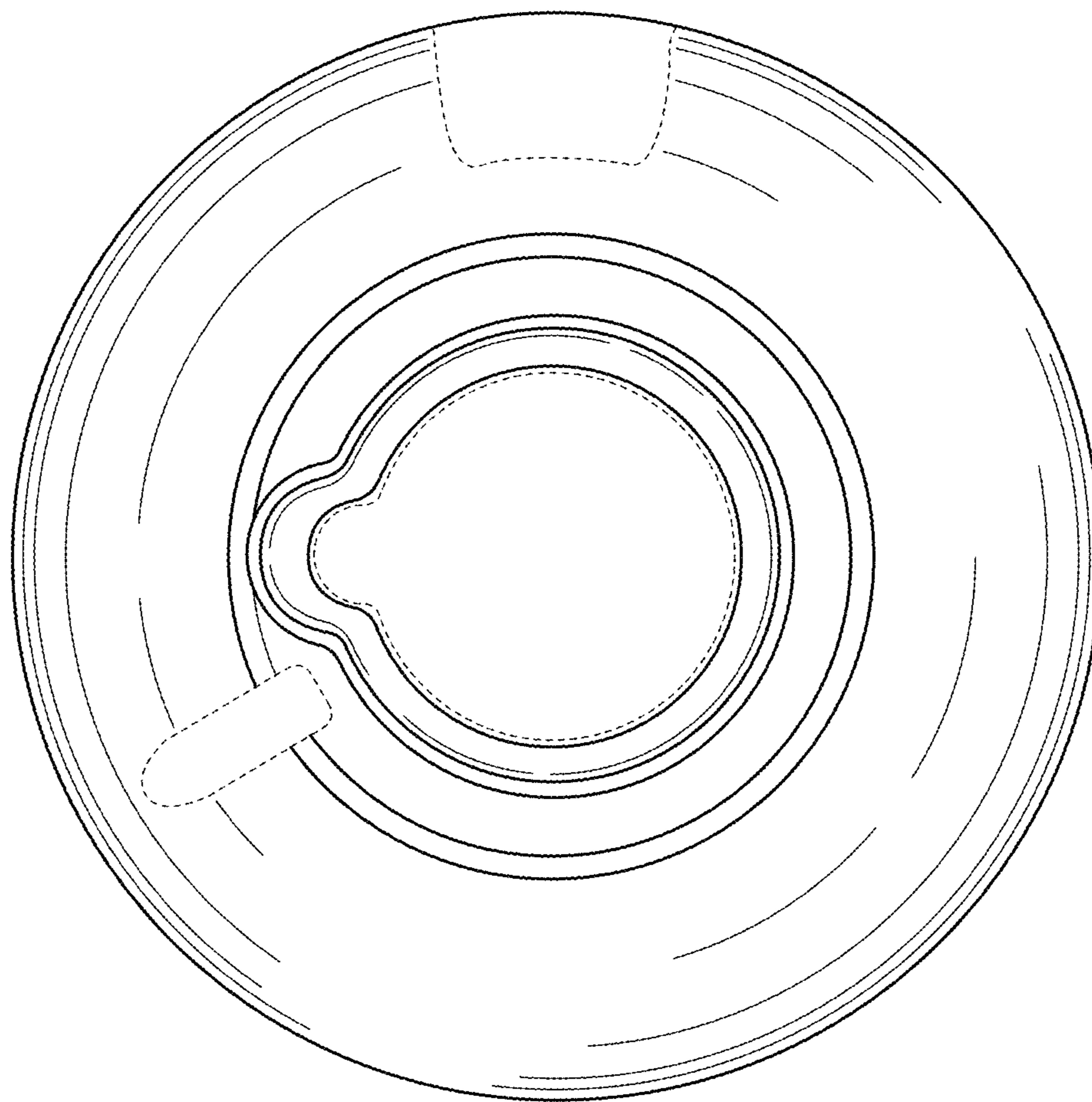

FIG. 7