



US00D791031S

(12) **United States Design Patent**
Lindsey

(10) **Patent No.:** **US D791,031 S**

(45) **Date of Patent:** **** *Jul. 4, 2017**

(54) **RIGHT DOOR SECTION FOR A CAR BODY**

(71) Applicant: **Robert Lindsey**, Braselton, GA (US)

(72) Inventor: **Robert Lindsey**, Braselton, GA (US)

(73) Assignee: **DELTAWING TECHNOLOGY GROUP, INC.**, Braselton, GA (US)

(*) Notice: This patent is subject to a terminal disclaimer.

(**) Term: **15 Years**

(21) Appl. No.: **29/539,072**

(22) Filed: **Sep. 10, 2015**

(51) **LOC (10) Cl.** **12-16**

(52) **U.S. Cl.**
USPC **D12/196**

(58) **Field of Classification Search**
USPC D12/86, 90-92, 190, 196
CPC B60R 13/04; B60R 19/54; B62D 25/12;
B62D 27/026; B62D 35/005; B60J
5/0412
See application file for complete search history.

(56) **References Cited**

U.S. PATENT DOCUMENTS

D55,441 S *	6/1920	Smith	D12/92
D82,044 S *	9/1930	Martin	D12/91
D469,387 S *	1/2003	Ramaciotti	D12/88
D507,992 S *	8/2005	Stephenson	D12/92
D528,945 S *	9/2006	Petrota	D12/92
D551,121 S *	9/2007	Schreyer	D12/92
D554,023 S *	10/2007	Davidson	D12/92
D588,958 S *	3/2009	Zheng	D12/92

D607,782 S *	1/2010	Yamazaki	D12/92
D614,535 S *	4/2010	Park	D12/92
D680,908 S *	4/2013	Cook	D12/92
D730,774 S *	6/2015	Bruce	D12/86
D753,549 S *	4/2016	Manzoni	D12/88

OTHER PUBLICATIONS

<http://www.tuvie.com/renault-e0-car-concept-with-solar-panel-roof/>—Downloaded May 9, 2016.*

<http://www.dezeen.com/2015/03/10/six-best-electric-hybrid-car-designs-geneva-motor-show/>—Published Mar. 10, 2015.*

* cited by examiner

Primary Examiner — Manpreet Matharu

Assistant Examiner — Mojtaba Tehrani

(74) *Attorney, Agent, or Firm* — Withers & Keys, LLC

(57) **CLAIM**

The ornamental design for a right door section for a car body, as shown and described.

DESCRIPTION

FIG. 1 is a front right perspective view of the right door section for a car body;

FIG. 2 is a front left perspective view thereof;

FIG. 3 is a front view thereof;

FIG. 4 is a rear view thereof;

FIG. 5 is a top view thereof;

FIG. 6 is a bottom view thereof;

FIG. 7 is a right view thereof; and,

FIG. 8 is a left view thereof.

The evenly broken line in the figure drawings represents unclaimed environment only and forms no part of the claimed design. The dash-dot broken line represents the boundaries and forms no part of the claimed design.

1 Claim, 8 Drawing Sheets

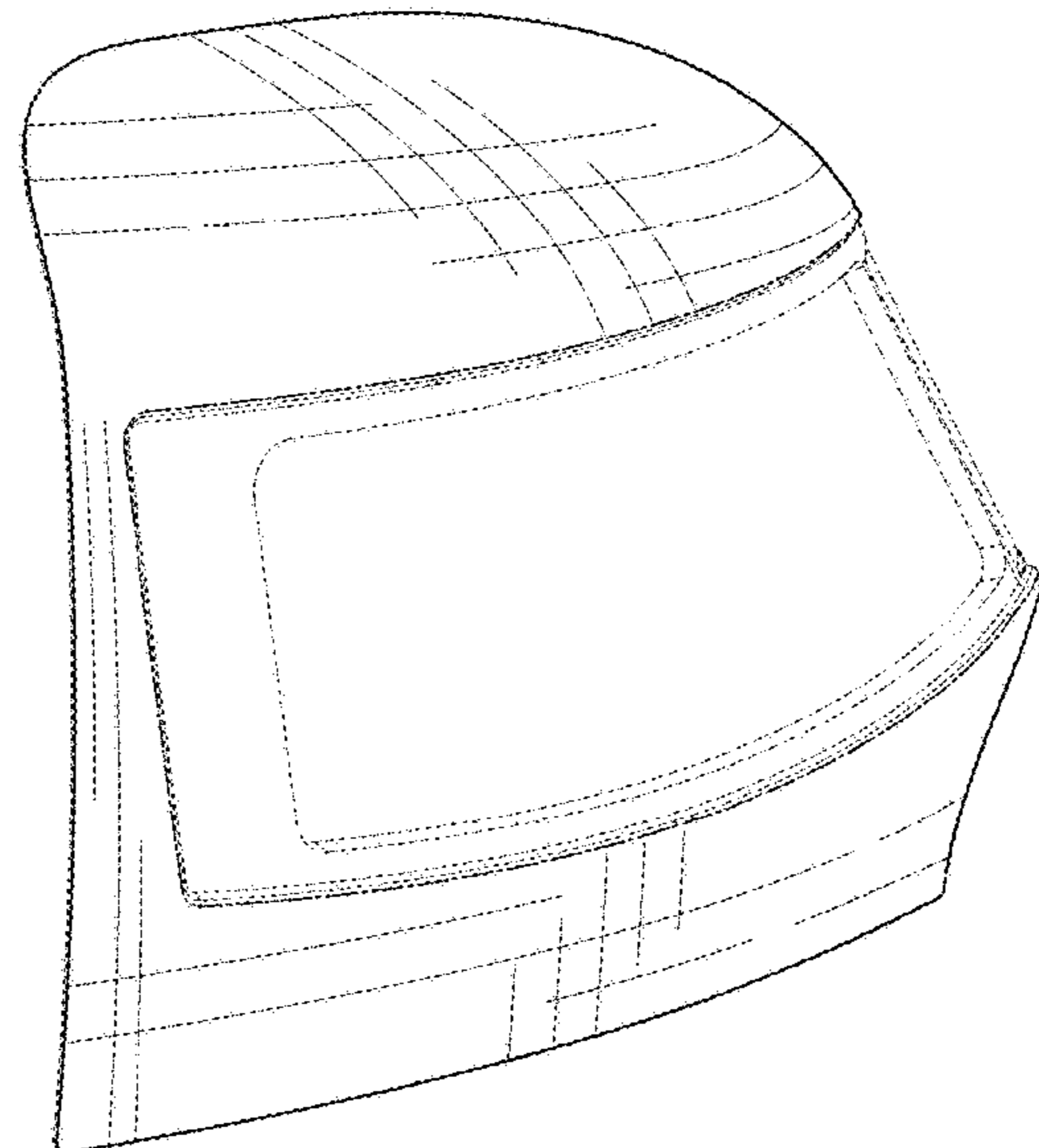
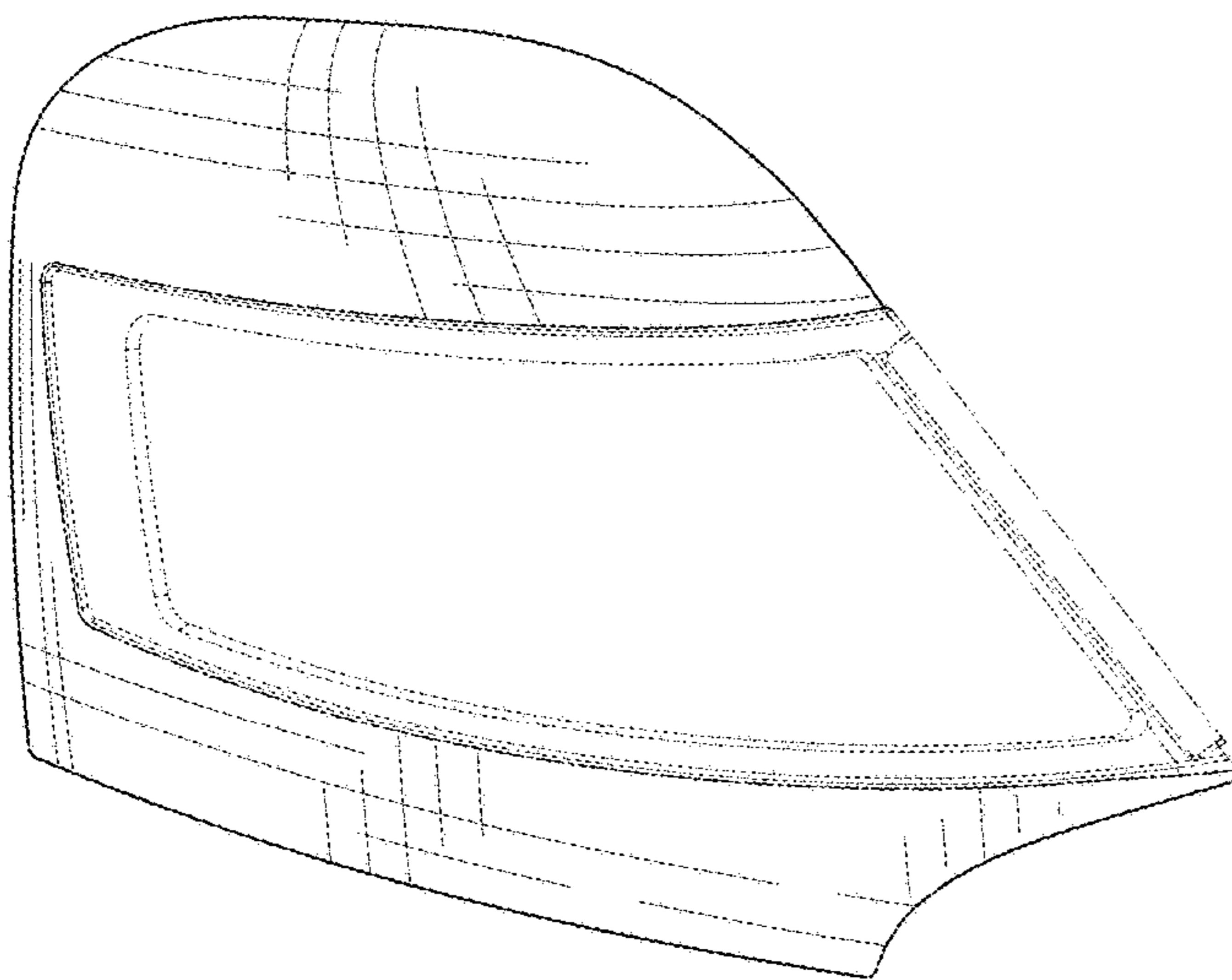

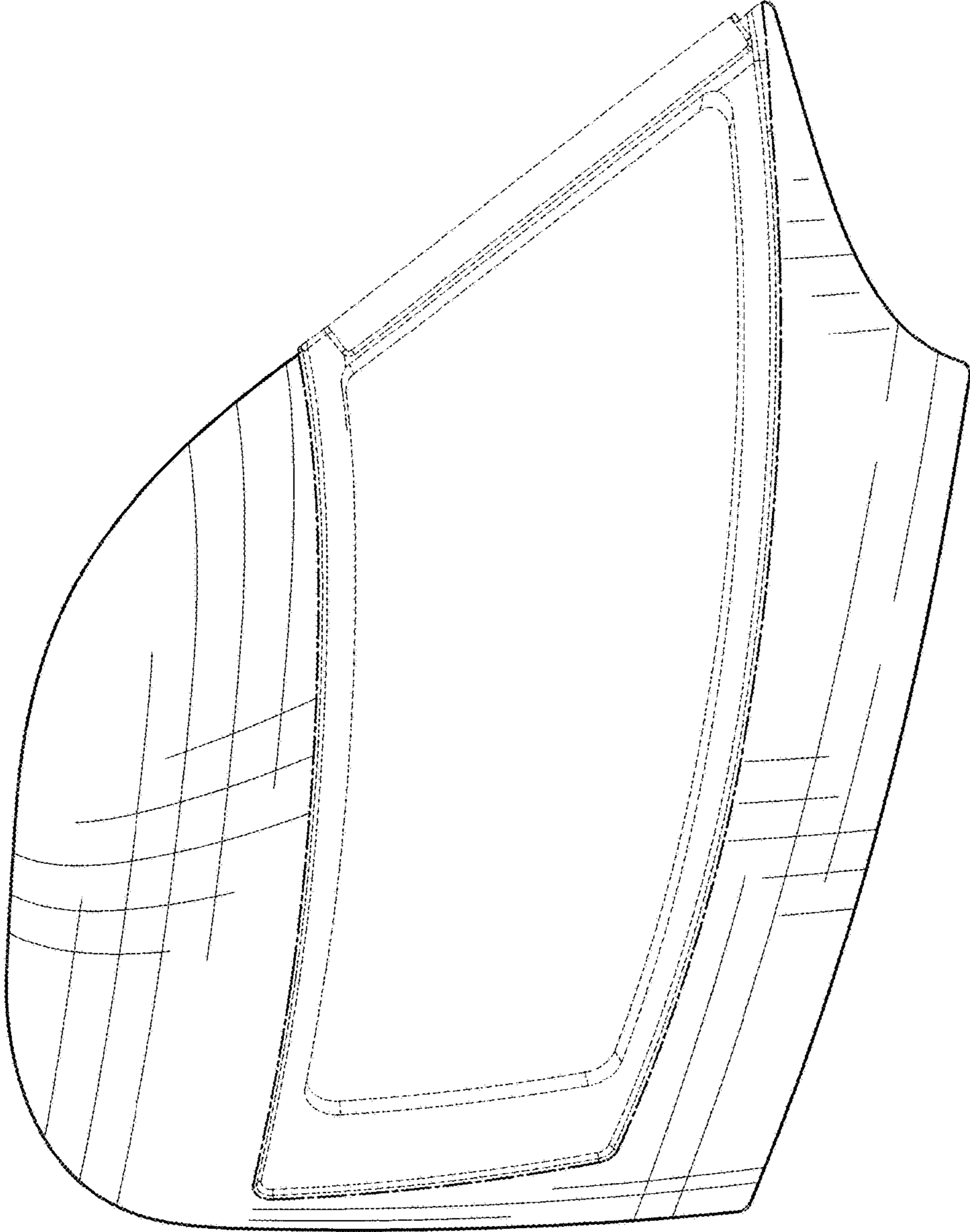

FIG. 1

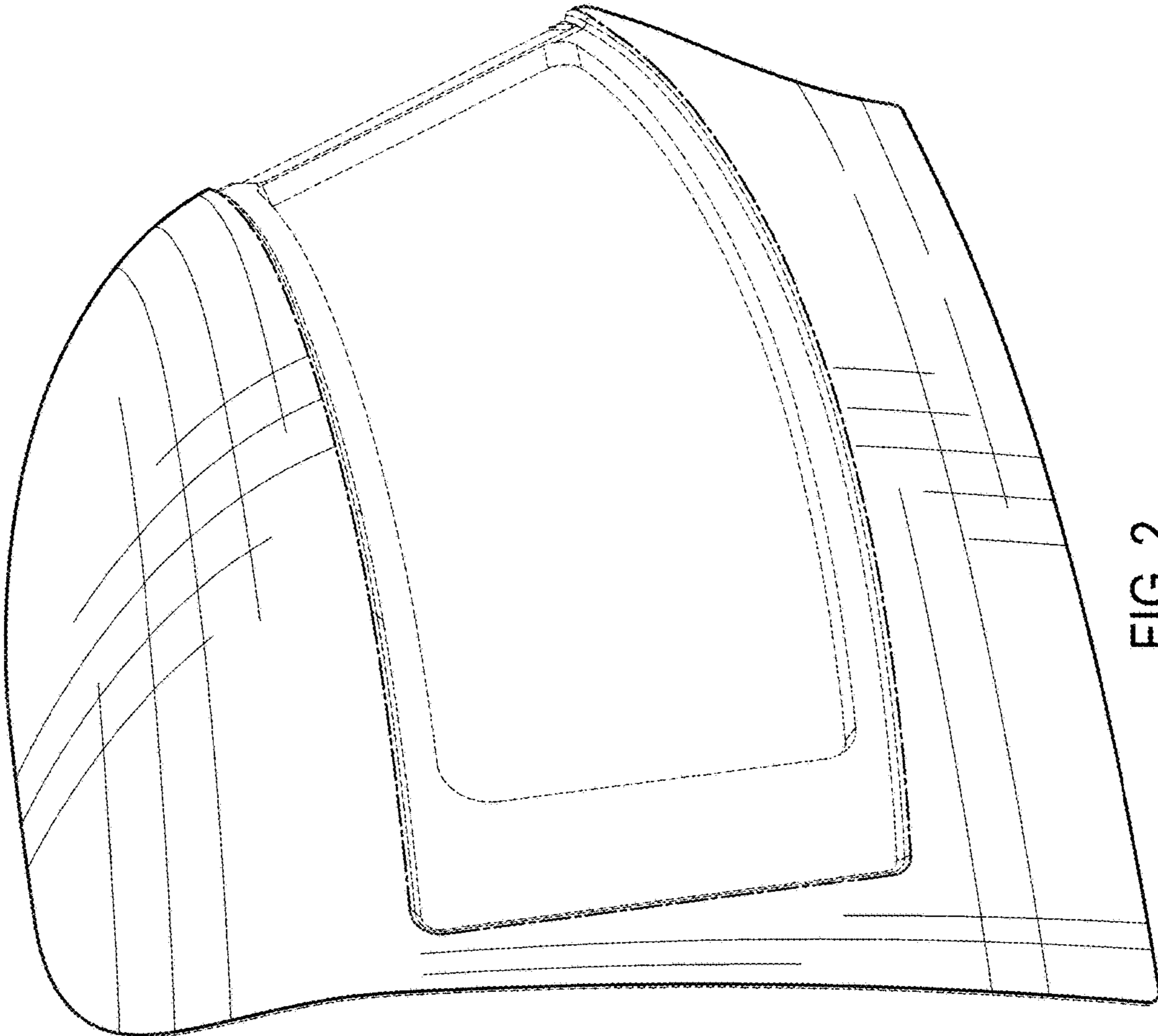

FIG. 2

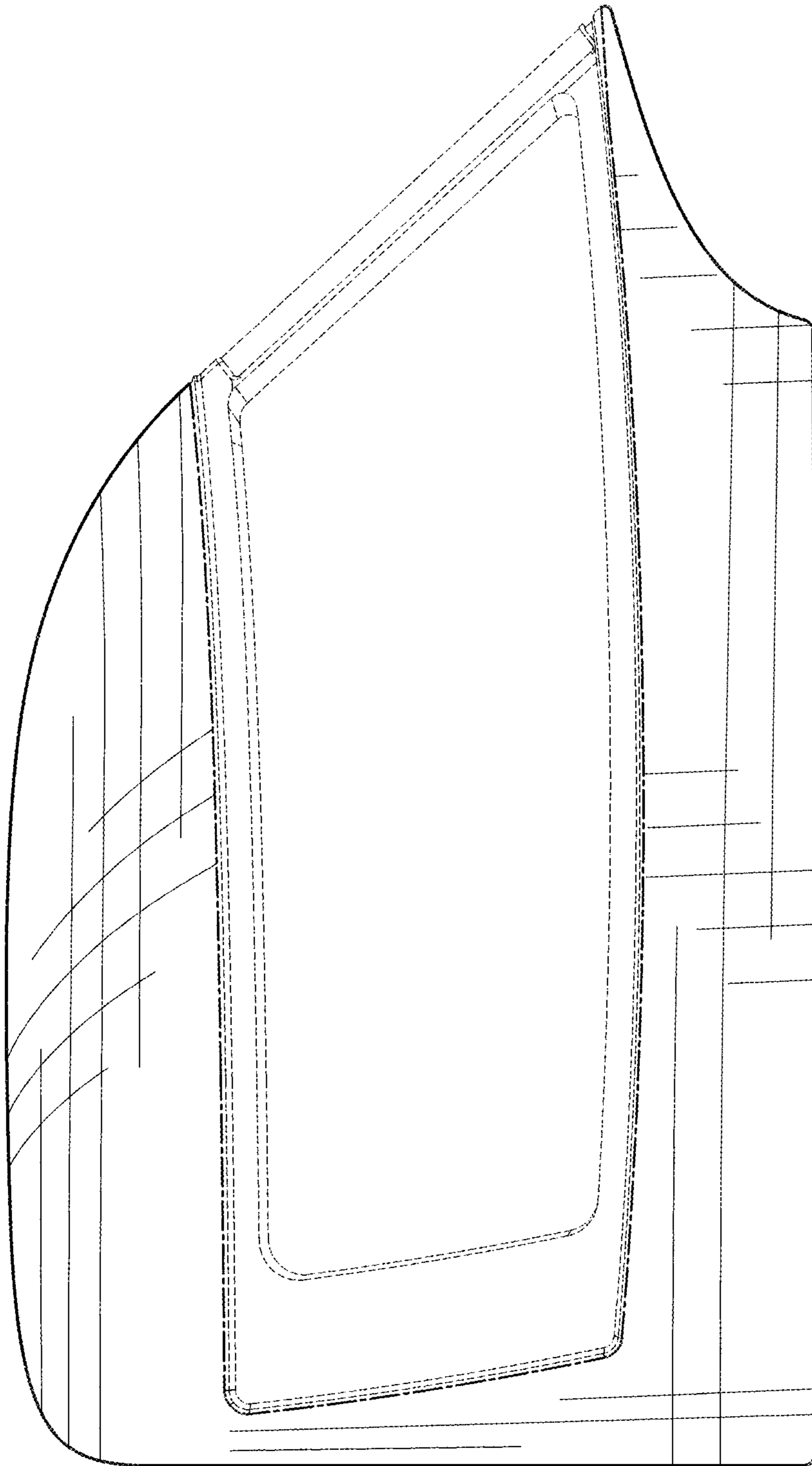

FIG. 3

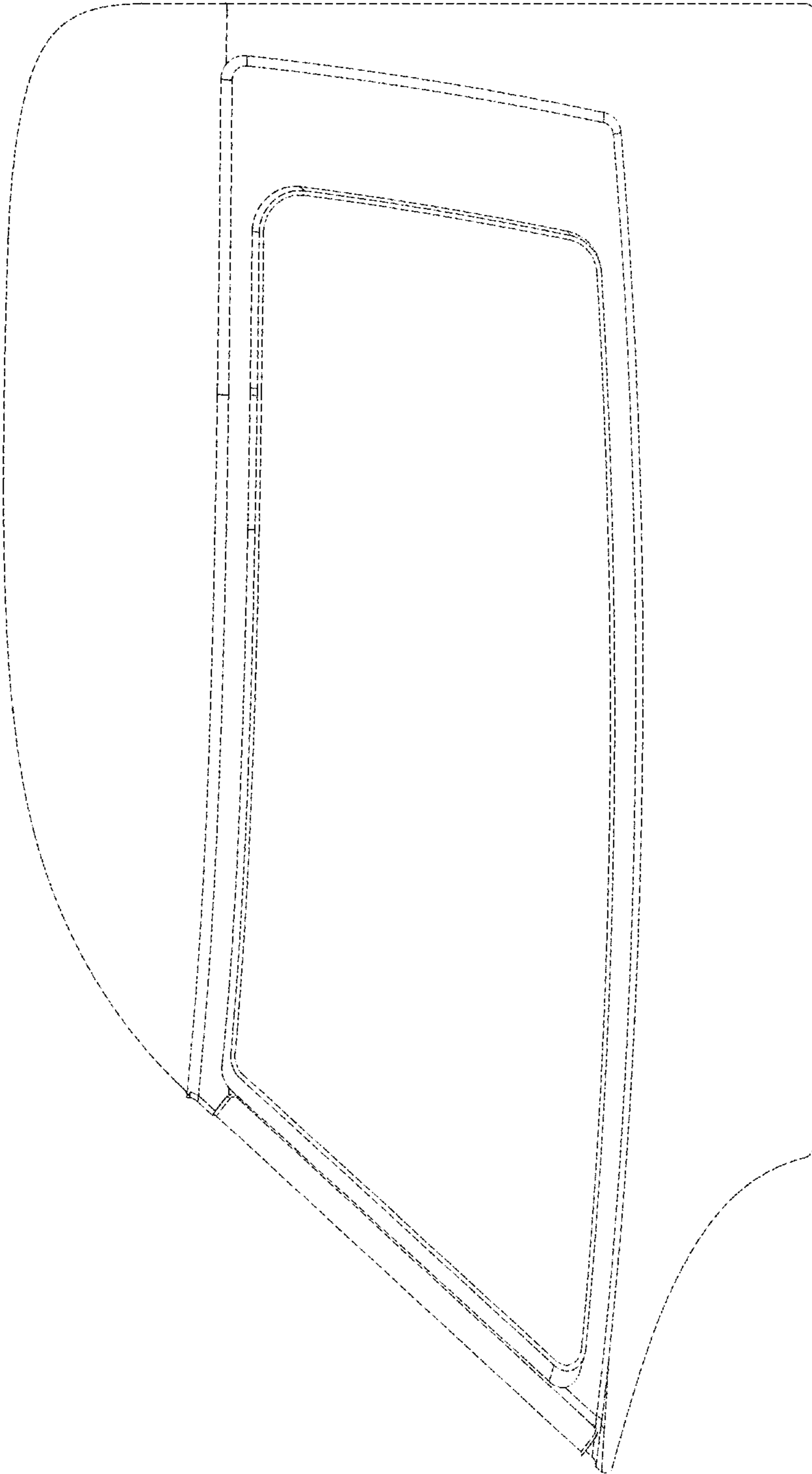

FIG. 4

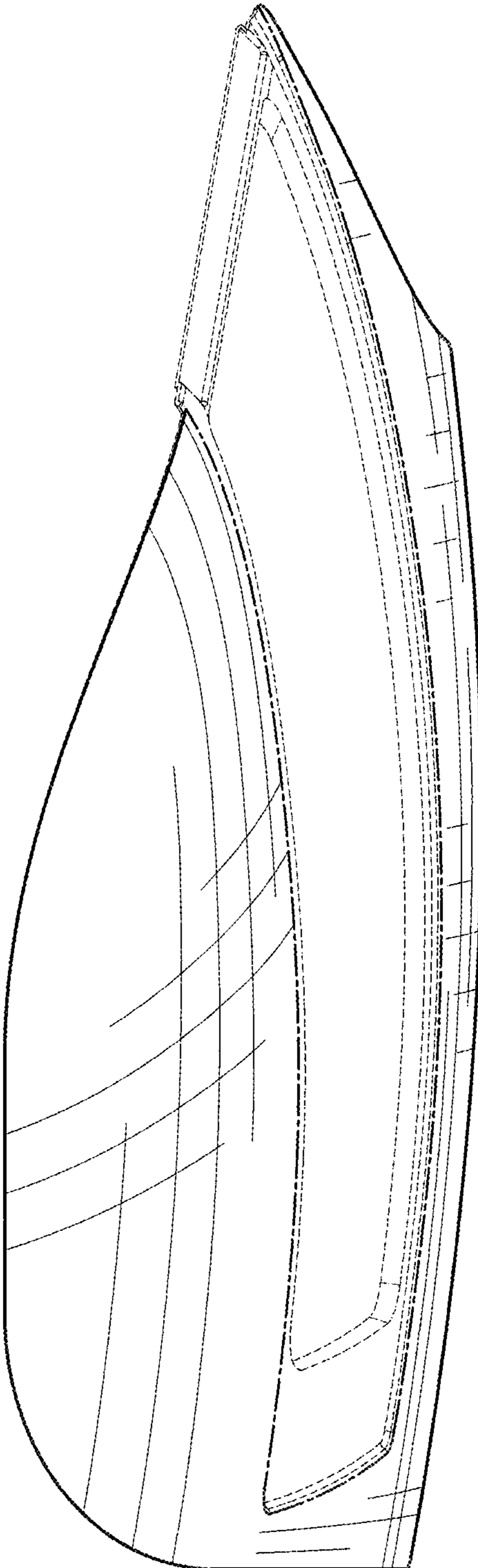

FIG. 5

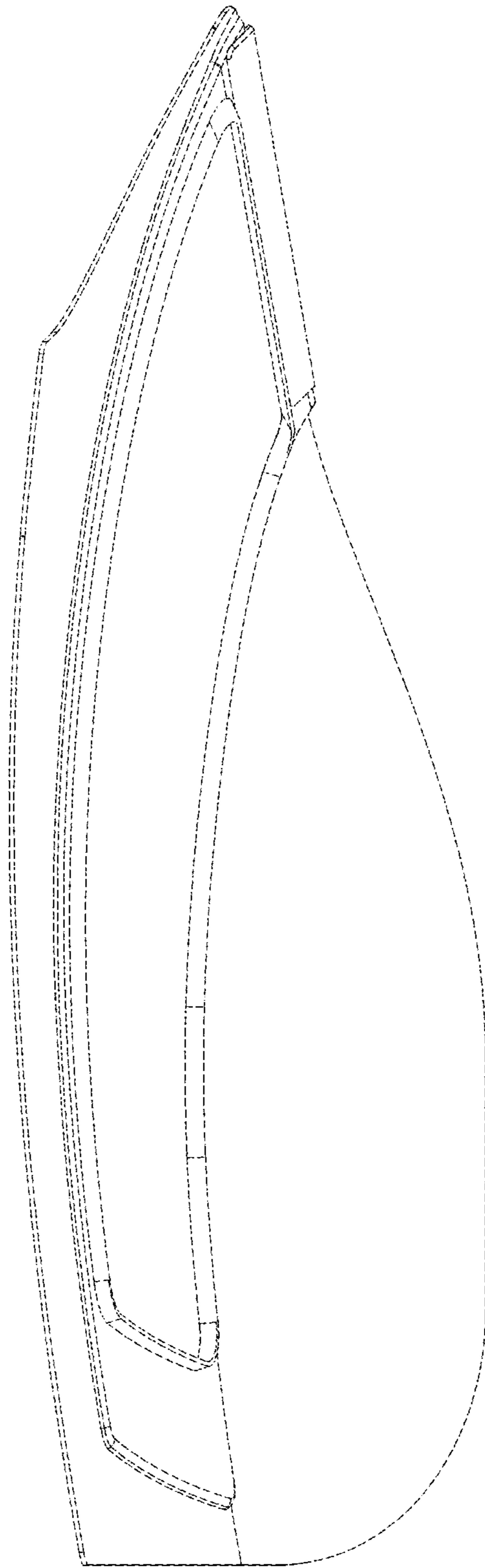

FIG. 6

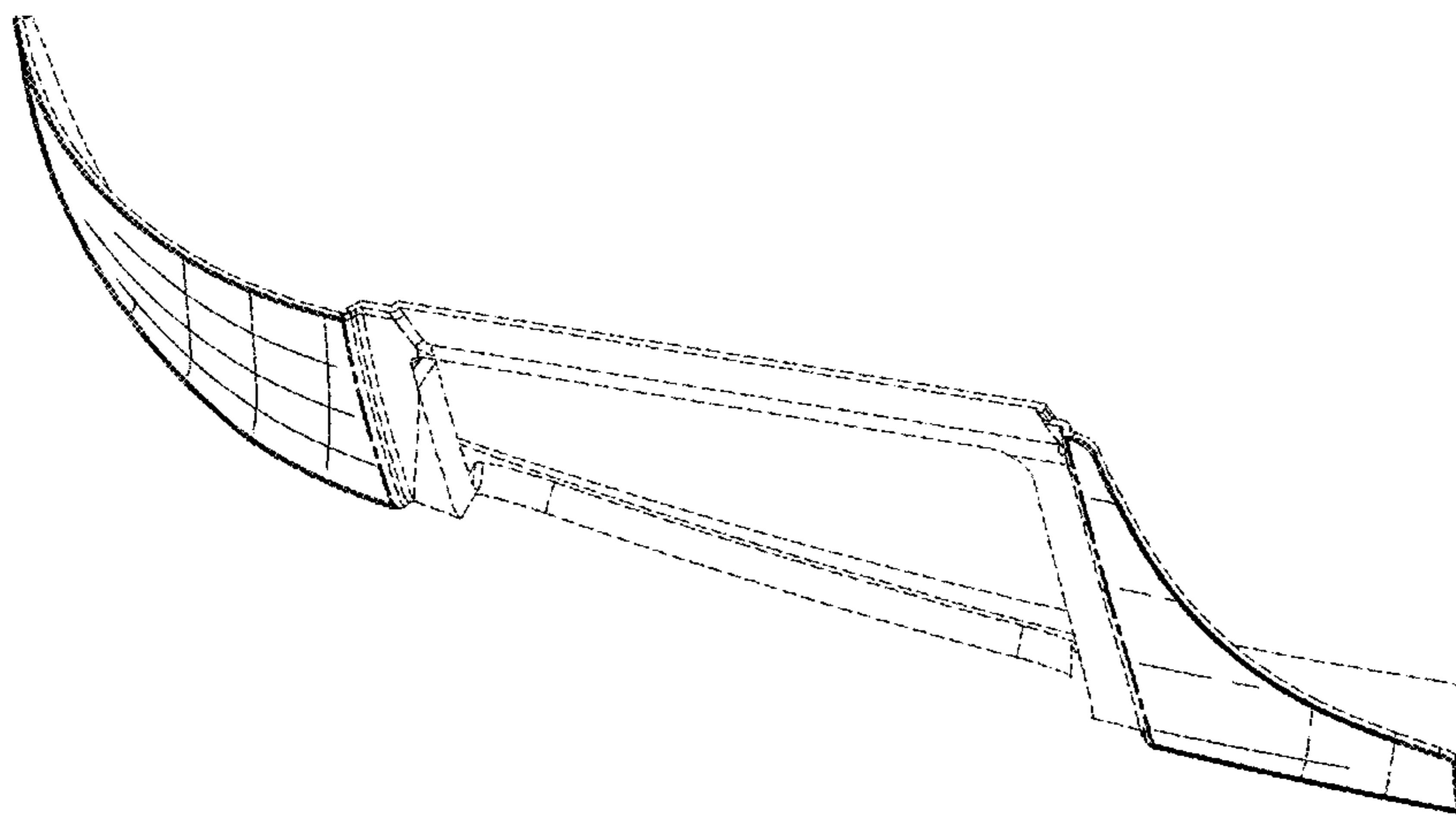

FIG. 7

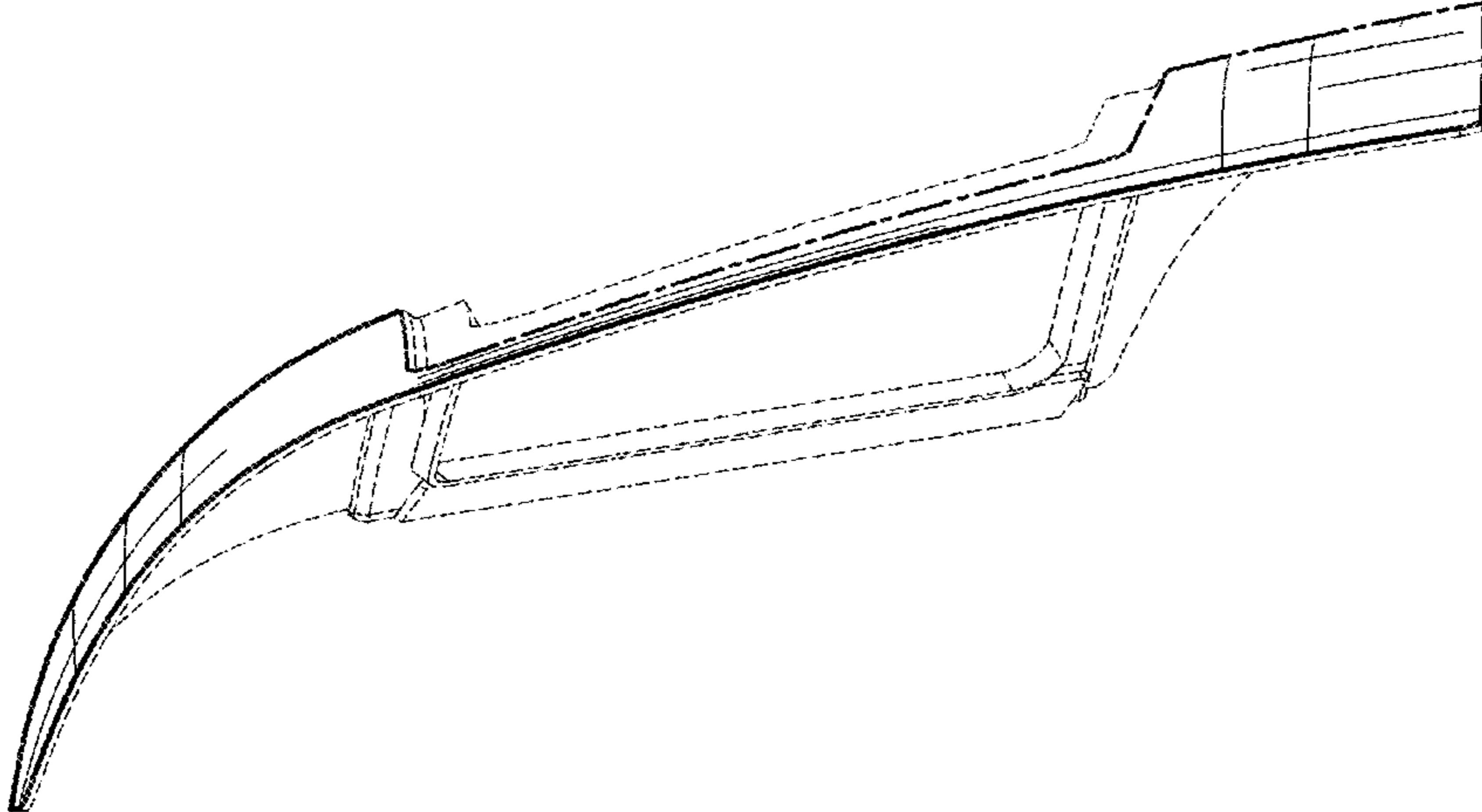

FIG. 8