



US00D790947S

(12) **United States Design Patent**
Key et al.

(10) **Patent No.:** **US D790,947 S**

(45) **Date of Patent:** **** Jul. 4, 2017**

(54) **CABINET HANDLE**

D773,919 S * 12/2016 Carlino D8/315
D773,920 S * 12/2016 Funnell, II D8/315
D776,854 S * 1/2017 Baumeister D26/76

(71) Applicant: **METALIA INC.**, Chambly (CA)

(72) Inventors: **Serge Key**, Boloeil (CA); **Kevin Key**,
Otterburn Park (CA); **Jacques**
Desbiens, Montreal (CA)

FOREIGN PATENT DOCUMENTS

CA D161829 11/2015

(73) Assignee: **METALIA INC.**, Chambly (CA)

OTHER PUBLICATIONS

(**) Term: **15 Years**

Ergonomic Drawer Handle With Patented Design: Announced 2016
[online], site visited Mar. 30, 2017. Available from Internet URL:
<http://www.metalia.com/explorer-modular-cabinets#slide10>.*

(21) Appl. No.: **29/557,479**

* cited by examiner

(22) Filed: **Mar. 9, 2016**

Primary Examiner — Caron D Veynar

(51) **LOC (10) Cl.** **08-06**

Assistant Examiner — Melvin Davis

(52) **U.S. Cl.**

(74) *Attorney, Agent, or Firm* — Gwendoline Bruneau

USPC **D8/315**

(58) **Field of Classification Search**

(57) **CLAIM**

USPC D8/302, 305, 311, 319; D26/89

The ornamental design for a cabinet handle, as shown and
described.

CPC E05B 1/0015; E05B 1/00

See application file for complete search history.

DESCRIPTION

(56) **References Cited**

FIG. 1 is a perspective view of the cabinet handle;
FIG. 2 is side view of the cabinet handle of FIG. 1, with the
other side being a mirror thereof;
FIG. 3 is a top view of the cabinet handle of FIG. 1;
FIG. 4 is a front view of the cabinet handle of FIG. 1;
FIG. 5 is a bottom view of the cabinet handle of FIG. 1; and,
FIG. 6 is a rear view of the cabinet handle of FIG. 1.
The broken lines shown in the figures are included for the
purpose of illustrating environment and form no part of the
claimed design.

U.S. PATENT DOCUMENTS

D246,949 S * 1/1978 Davis D8/300
D451,359 S * 12/2001 DePass D8/302
D562,361 S * 2/2008 Kwak D15/89
D588,172 S * 3/2009 Yang D15/89
D610,594 S * 2/2010 Martin D15/89
D709,636 S * 7/2014 Murata D26/72
D711,938 S * 8/2014 Boo D15/89
D729,423 S * 5/2015 Noh D26/24
D763,656 S * 8/2016 Lee D8/317
D764,890 S * 8/2016 Shoemaker D15/89

1 Claim, 2 Drawing Sheets

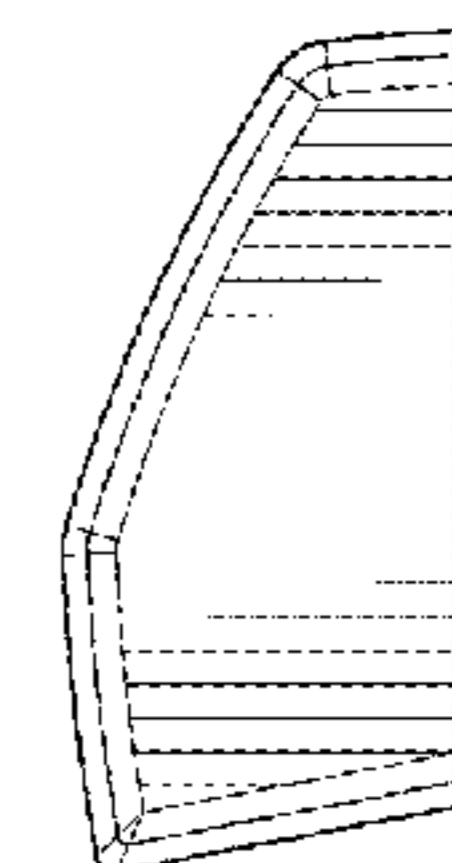
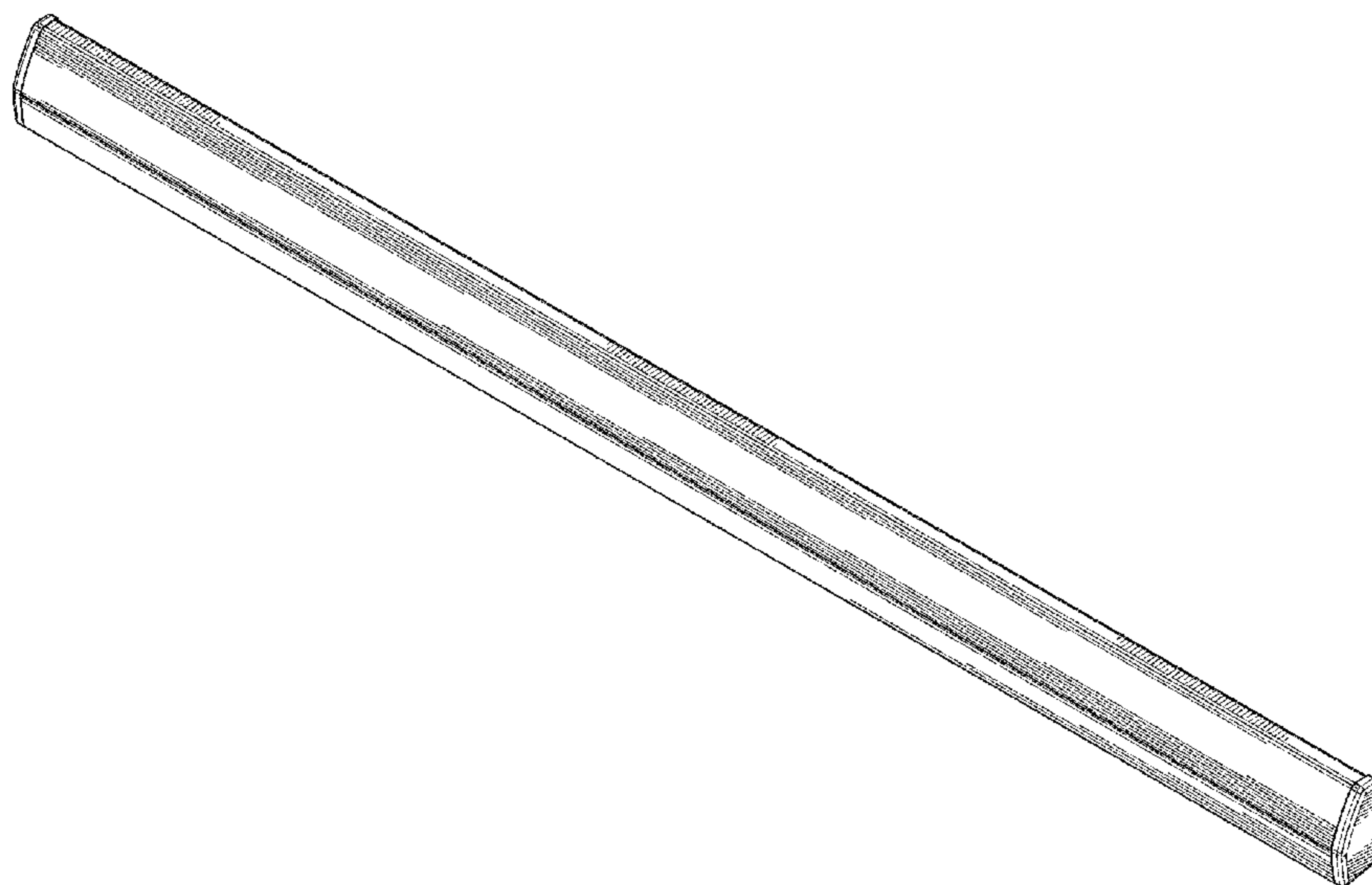

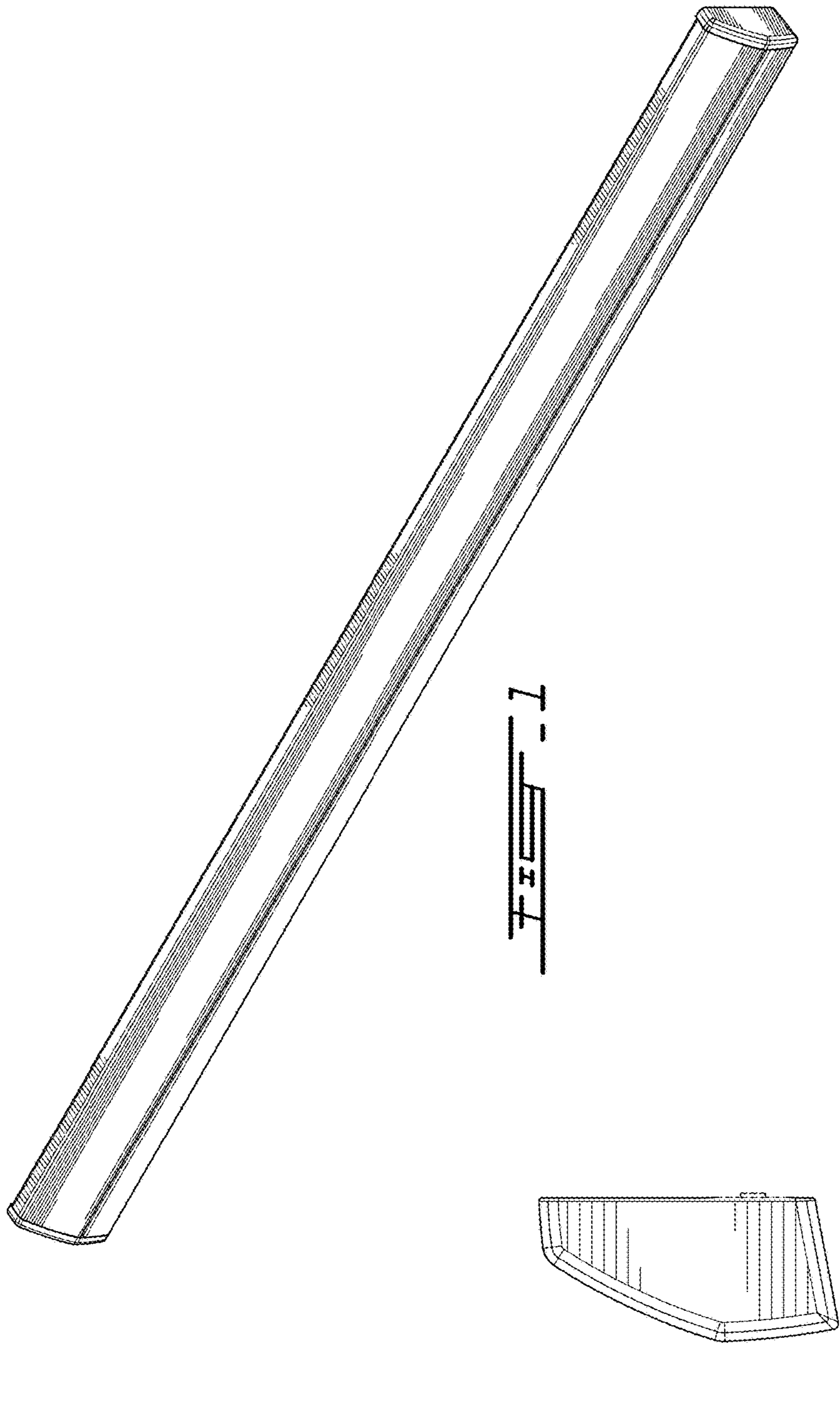



FIG. 3

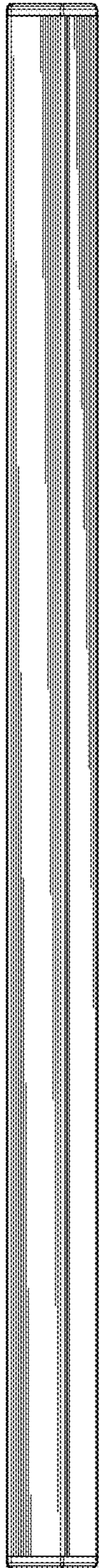

FIG. 4

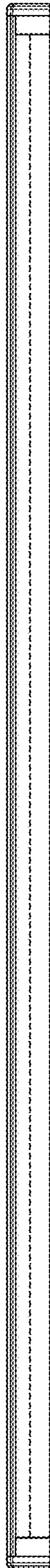

FIG. 5

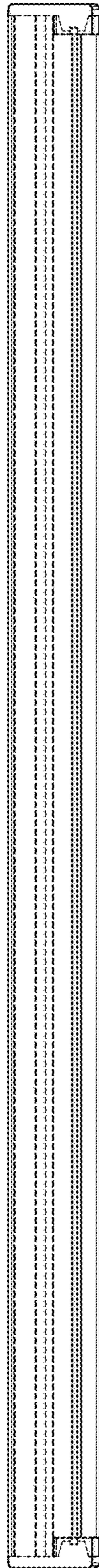

FIG. 6