



US00D790614S

(12) **United States Design Patent**  
**Haimer**

(10) **Patent No.:** **US D790,614 S**  
(45) **Date of Patent:** **\*\* Jun. 27, 2017**

- (54) **HEAT SHRINKING MACHINE**
- (71) Applicant: **Haimer GmbH**, Hollenbach-Igenhausen (DE)
- (72) Inventor: **Franz Haimer**, Igenhausen (DE)
- (73) Assignee: **Haimer GmbH**, Hollenbach-Igenhausen (DE)
- (\*\*) Term: **15 Years**
- (21) Appl. No.: **29/554,088**
- (22) Filed: **Feb. 8, 2016**

5,322,586	A *	6/1994	McLean	.....	B29C 65/18
					100/50
5,894,709	A *	4/1999	Fosshage	.....	B65B 9/067
					493/191
5,930,983	A *	8/1999	Terminella	.....	B65B 9/20
					53/133.4
6,332,305	B1 *	12/2001	Takahashi	.....	B29C 65/18
					493/271
6,689,180	B1 *	2/2004	Liao	.....	B65B 53/063
					34/211
6,761,016	B1 *	7/2004	Soleri	.....	B65B 9/023
					53/552
6,854,242	B2 *	2/2005	Stork	.....	B65B 9/067
					209/203

(Continued)

(30) **Foreign Application Priority Data**

Aug. 6, 2015 (EM) ..... 002750588-0013

(51) **LOC (10) Cl.** ..... **15-99**

(52) **U.S. Cl.**  
USPC ..... **D15/146**

(58) **Field of Classification Search**  
USPC ..... D15/122, 145, 146  
CPC ..... B65B 9/067; B65B 59/00; B65B 57/12  
See application file for complete search history.

(56) **References Cited**

**U.S. PATENT DOCUMENTS**

3,392,506	A *	7/1968	Haines	.....	B29C 65/18
					53/329.3
4,001,066	A *	1/1977	Channing	.....	B29C 65/02
					156/152
4,176,507	A *	12/1979	Mancini	.....	B65B 7/2878
					53/282
4,418,513	A *	12/1983	Plahm	.....	B65B 31/042
					53/373.2
D277,386	S *	1/1985	Yamada	.....	D15/146
D285,799	S *	9/1986	Yamada	.....	D15/146
D289,054	S *	3/1987	Coleby	.....	D15/127
5,152,806	A *	10/1992	Piper	.....	B29C 65/78
					29/623.1

**OTHER PUBLICATIONS**

Non-final Office Action issued in connection with U.S. Appl. No. 29/554,084, dated Dec. 21, 2016.

(Continued)

*Primary Examiner* — Patricia Palasik  
(74) *Attorney, Agent, or Firm* — Meunier Carlin & Curfman LLC

(57) **CLAIM**

The ornamental design for a heat shrinking machine, as shown and described.

**DESCRIPTION**

FIG. 1 is a perspective view of my new design;  
FIG. 2 is a front view thereof;  
FIG. 3 is a rear view thereof;  
FIG. 4 is a top view thereof;  
FIG. 5 is a bottom view thereof;  
FIG. 6 is a right-side view thereof; and,  
FIG. 7 is a left-side view thereof.  
The broken lines in the drawings depict unclaimed environmental subject matter.

**1 Claim, 7 Drawing Sheets**

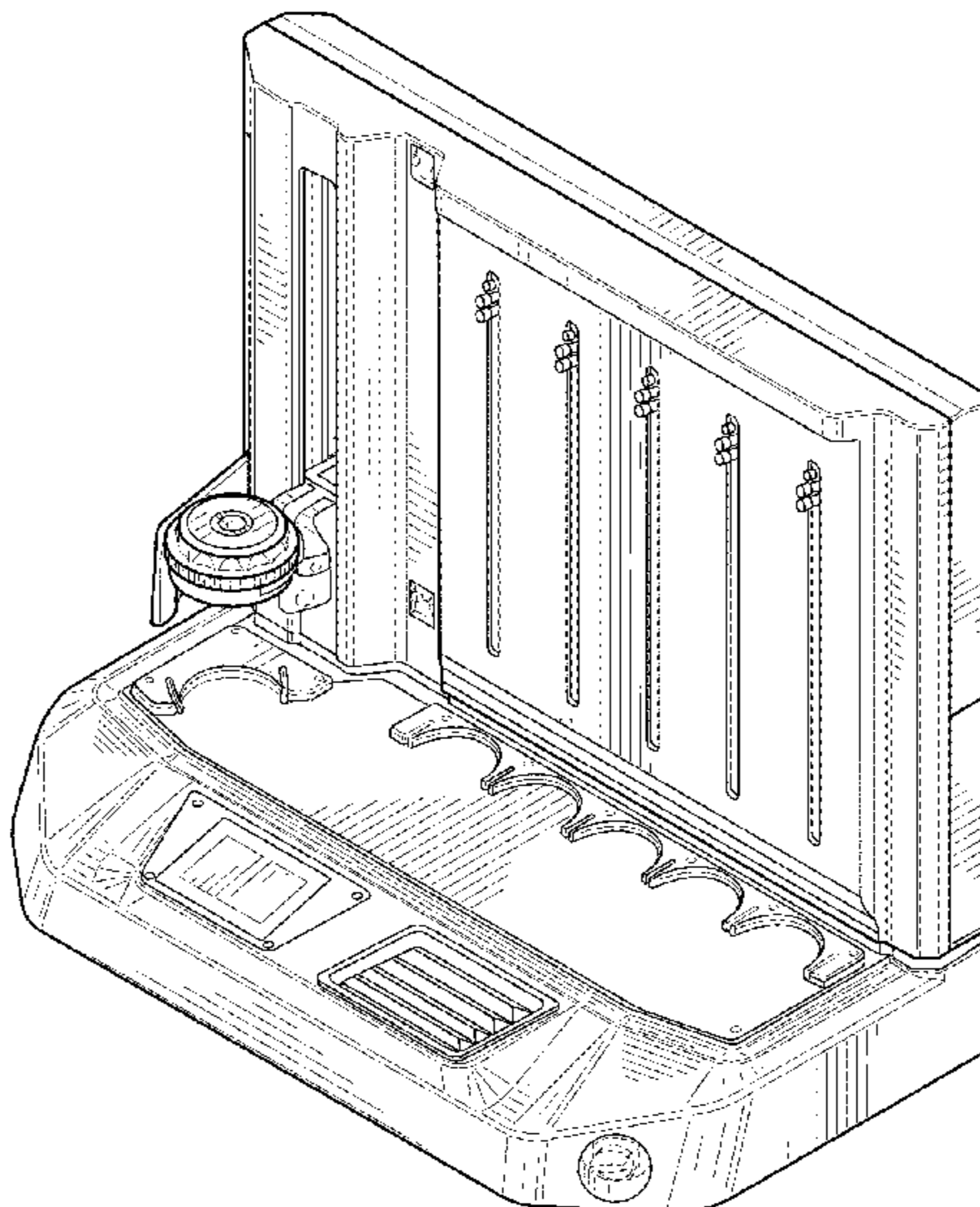

(56)

**References Cited**

U.S. PATENT DOCUMENTS

7,325,374 B2 \* 2/2008 Chrisman ..... B65B 9/02  
53/203  
8,051,629 B2 \* 11/2011 Pazdernik ..... B65B 53/063  
219/388  
8,087,220 B2 \* 1/2012 Uttaro ..... B26D 1/565  
53/374.6  
8,631,555 B1 \* 1/2014 Favale ..... B65B 53/063  
29/525.01  
2002/0055803 A1 \* 5/2002 Stork ..... B65B 9/067  
700/112  
2004/0128957 A1 \* 7/2004 Guzman ..... B29C 66/73715  
53/550  
2004/0256058 A1 \* 12/2004 Irwin ..... B29C 65/18  
156/580  
2006/0272291 A1 \* 12/2006 Koke ..... B65B 31/024  
53/432

2010/0263336 A1 \* 10/2010 Uttaro ..... B26D 1/565  
53/550  
2011/0076079 A1 \* 3/2011 Robinson ..... B30B 15/028  
400/76  
2014/0196407 A1 \* 7/2014 Ghirardello ..... B65B 55/103  
53/426  
2016/0200470 A1 \* 7/2016 Zoboli ..... B65B 35/36  
53/441  
2016/0332755 A1 \* 11/2016 Yasuda ..... B29C 65/743

OTHER PUBLICATIONS

Non-final Office Action issued in connection with U.S. Appl. No.  
29/554,085, dated Dec. 22, 2016.  
Non-final Office Action issued in connection with U.S. Appl. No.  
29/554,087, dated Dec. 22, 2016.  
Non-final Office Action issued in connection with U.S. Appl. No.  
29/554,083, dated Dec. 21, 2016.

\* cited by examiner

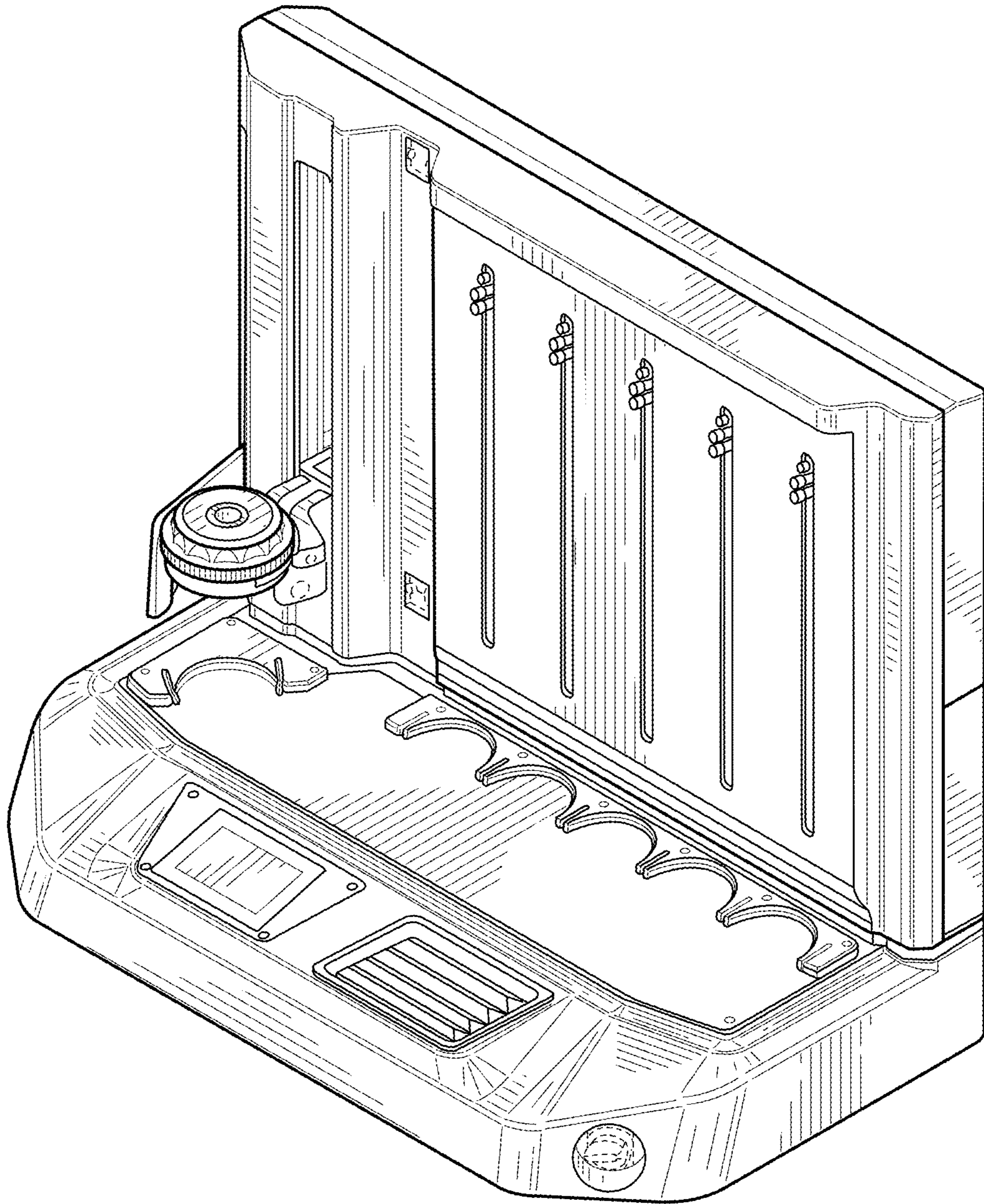

FIG. 1



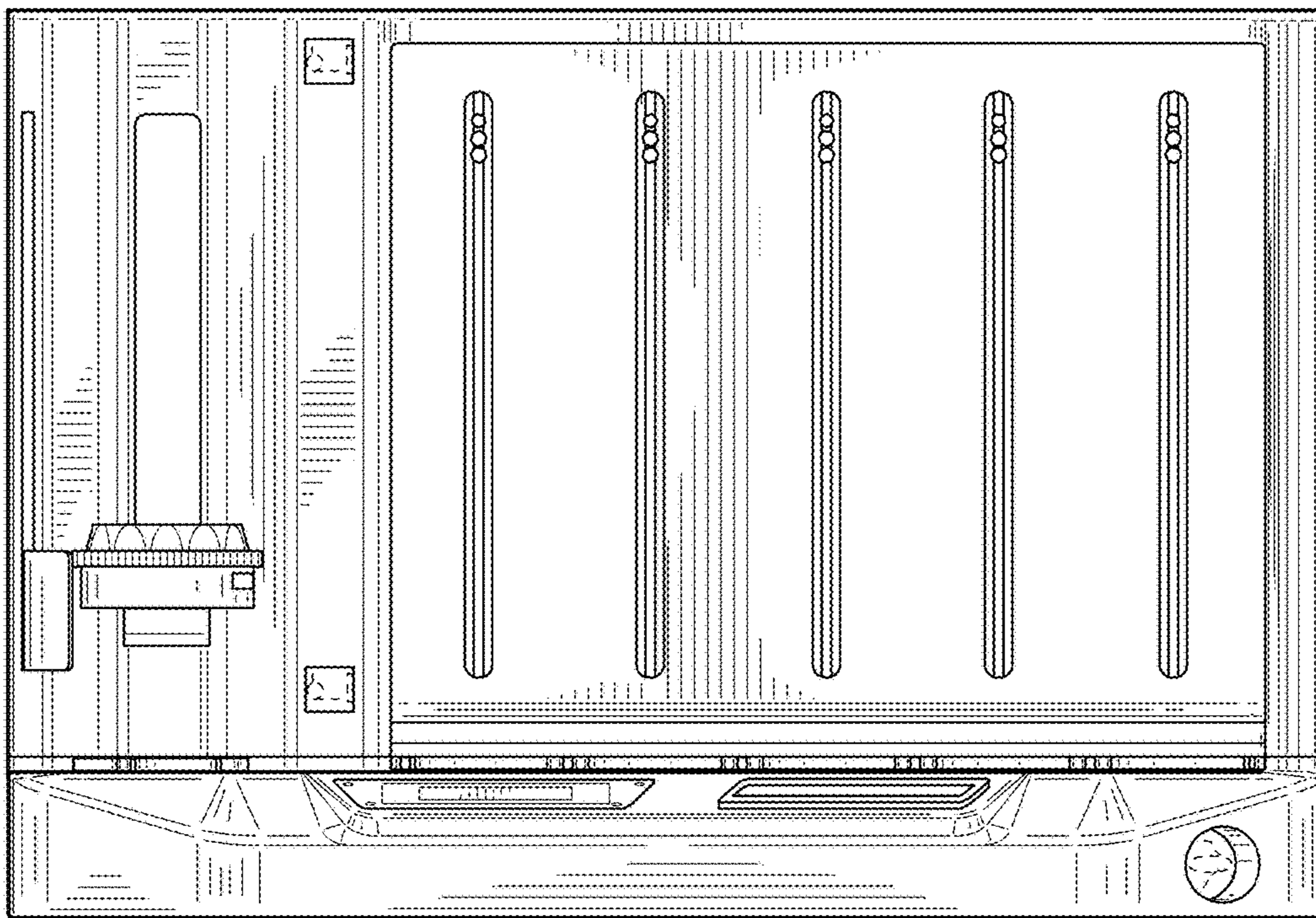

FIG. 2



*FIG. 3*

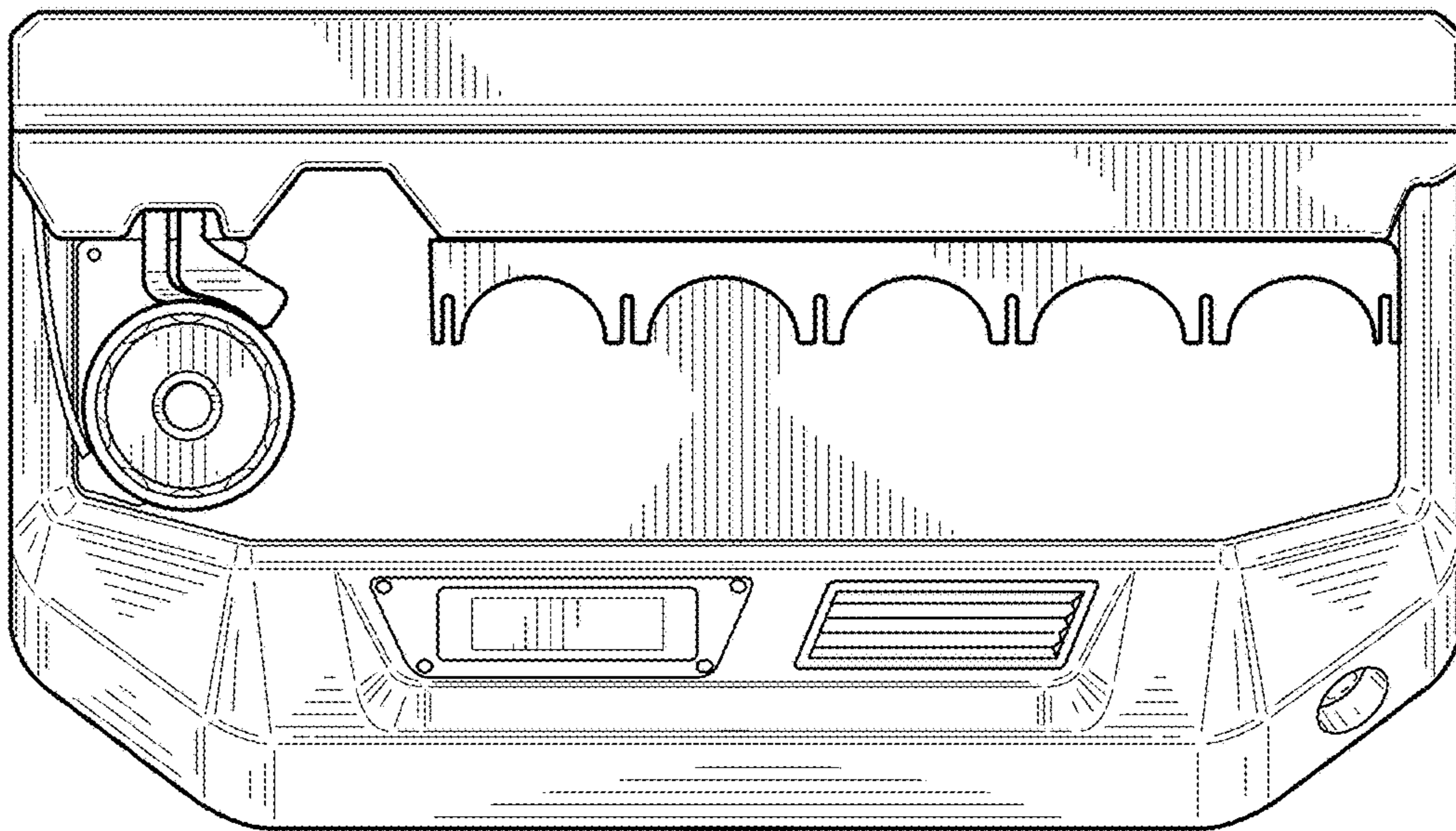
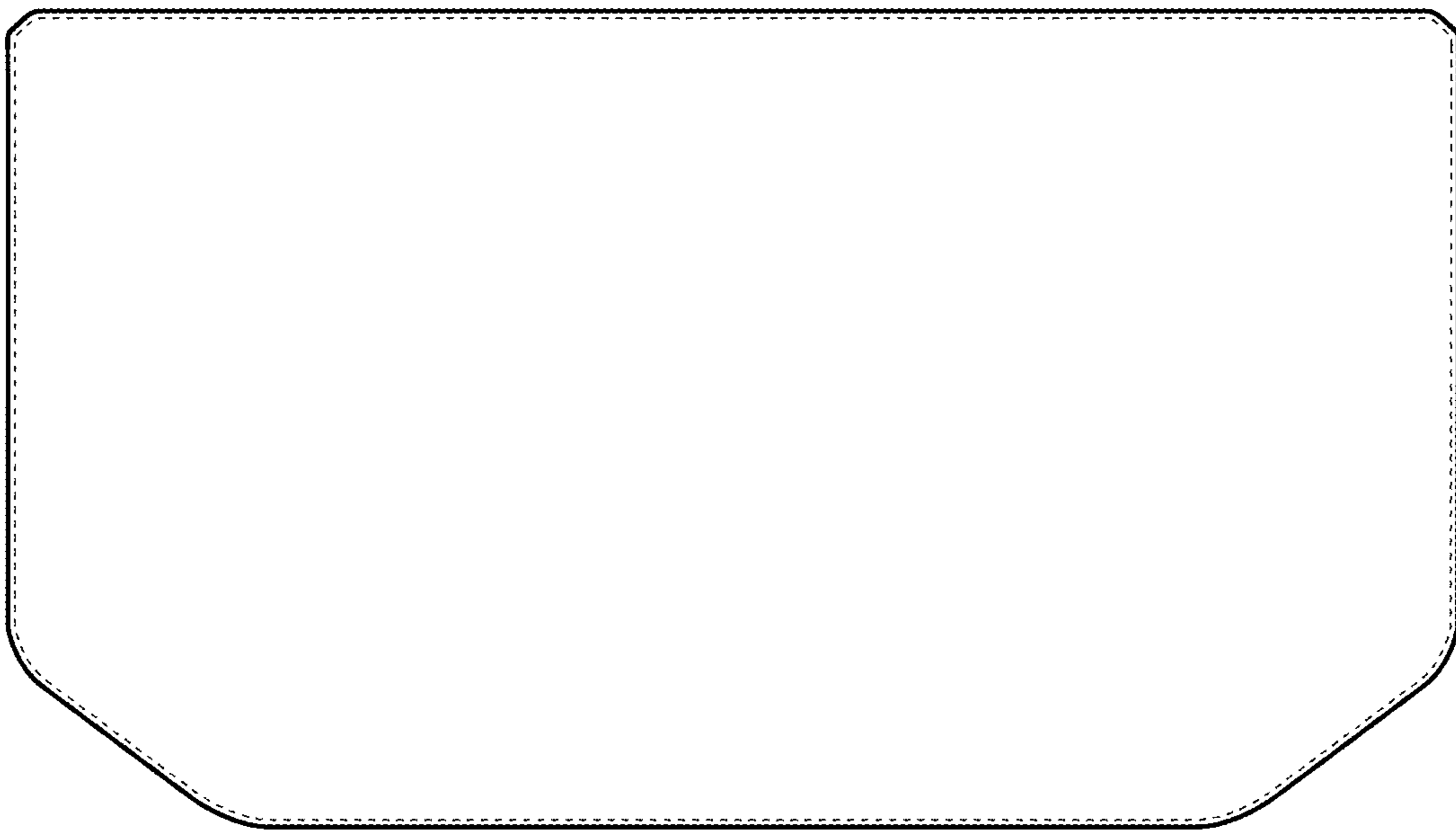

FIG. 4



*FIG. 5*

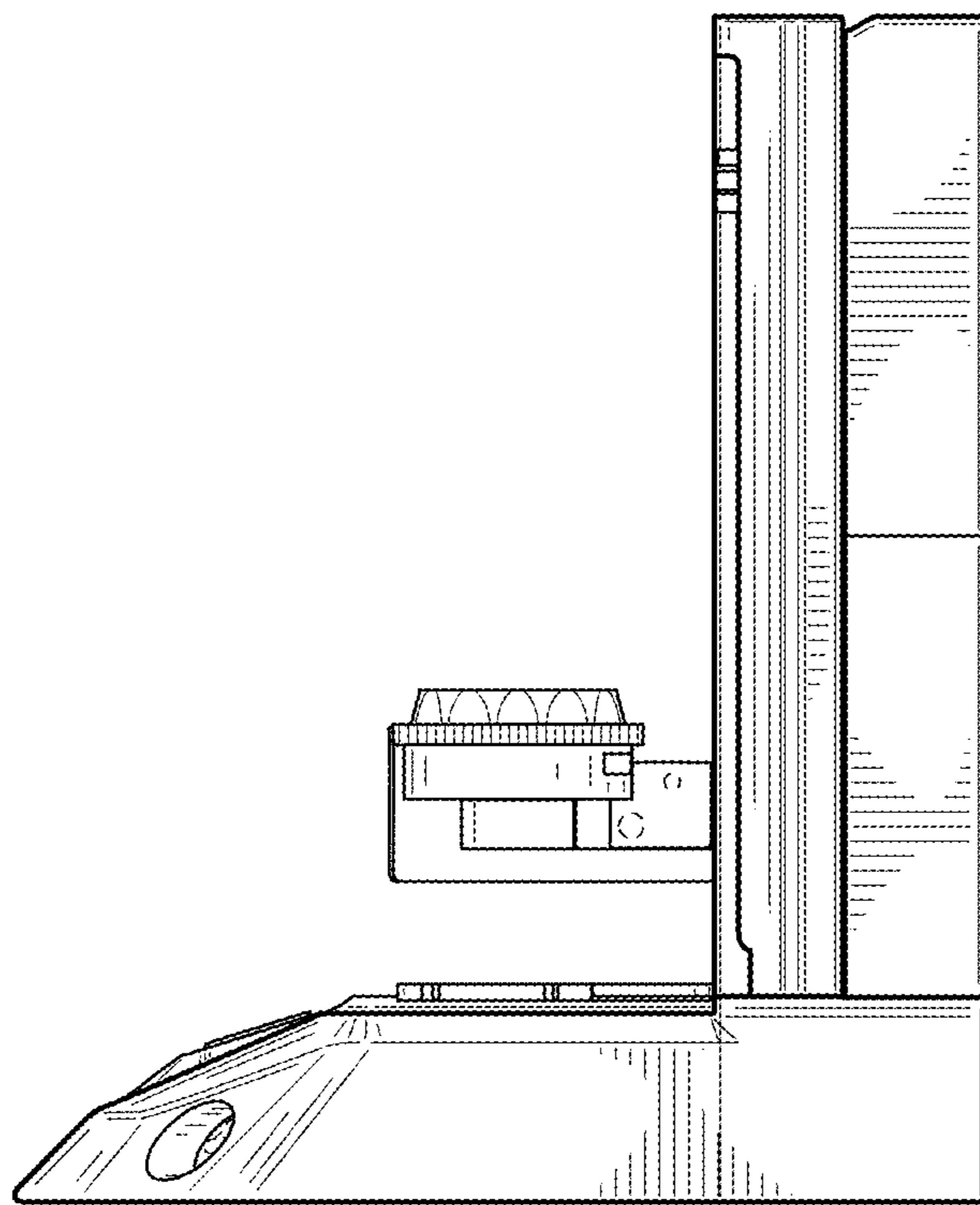
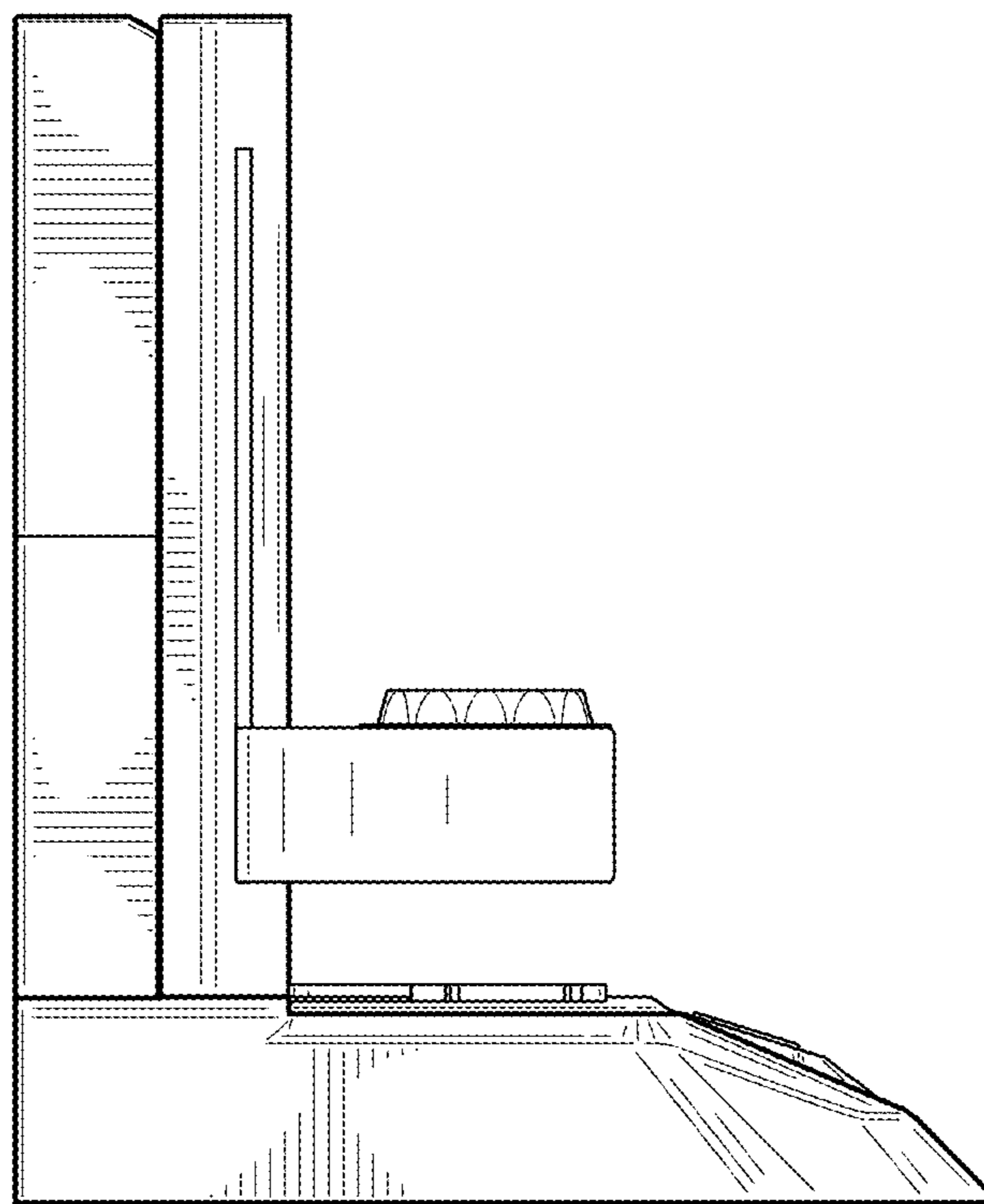

FIG. 6





**FIG. 7**