



US00D790420S

(12) **United States Design Patent**  
**Peat**

(10) **Patent No.:** **US D790,420 S**

(45) **Date of Patent:** **\*\* Jun. 27, 2017**

(54) **WHEEL**

(71) Applicant: **Jaguar Land Rover Limited**, Whitley,  
Coventry (GB)

(72) Inventor: **Anthony Peat**, Coventry (GB)

(73) Assignee: **Jaguar Limited Rover Limited**,  
Whitley, Coventry (GB)

(\*\*) Term: **14 Years**

(21) Appl. No.: **29/521,917**

(22) Filed: **Mar. 26, 2015**

(30) **Foreign Application Priority Data**

Sep. 29, 2014 (EM) ..... 002547414

(51) **LOC (10) Cl.** ..... **12-16**

(52) **U.S. Cl.**  
USPC ..... **D12/209**

(58) **Field of Classification Search**  
USPC ..... D12/204–213  
CPC .... B60B 7/00; B60B 7/02; B60B 7/04; B60B  
7/01; B60B 7/06; B60B 3/02; B60B 3/04;  
B60B 3/06; B60B 3/10; B60B 1/00;  
B60B 1/08; B60B 1/10; B60B 1/12  
See application file for complete search history.

(56) **References Cited**

**U.S. PATENT DOCUMENTS**

D411,502 S \* 6/1999 Chung ..... D12/211  
D418,797 S \* 1/2000 Chung ..... D12/209  
D444,119 S \* 6/2001 Brintouch ..... D12/211

D451,467 S \* 12/2001 Chung ..... D12/211  
D469,729 S \* 2/2003 Brintouch ..... D12/209  
D475,669 S \* 6/2003 Boyer ..... D12/209  
D504,647 S \* 5/2005 Leclercq ..... D12/209  
D507,224 S \* 7/2005 Pfeiffer ..... D12/211  
D520,434 S \* 5/2006 Fahr-Becker ..... D12/211  
D522,430 S \* 6/2006 Nordmann ..... D12/209  
D522,951 S \* 6/2006 Pfeiffer ..... D12/211  
D618,149 S \* 6/2010 Antoniadis ..... D12/209  
D621,766 S \* 8/2010 Antoniadis ..... D12/209  
D657,727 S \* 4/2012 Fetherston ..... D12/209  
D667,767 S \* 9/2012 Gotschke ..... D12/209  
D690,642 S \* 10/2013 Kito ..... D12/209  
D705,152 S \* 5/2014 Nakamura ..... D12/209  
D739,327 S \* 9/2015 Wagener ..... D12/209

\* cited by examiner

*Primary Examiner* — Stacia Cadmus

(74) *Attorney, Agent, or Firm* — Wood Herron & Evans  
LLP

(57) **CLAIM**

The ornamental design for a wheel, as shown and described.

**DESCRIPTION**

FIG. 1 is a left front perspective view of a wheel according to the invention.

FIG. 2 is a front view of the wheel shown in FIG. 1; and, FIG. 3 is a right side view of the wheel shown in FIG. 1, the left side view being a mirror image thereof.

The broken line showing of the rear of the rim, the valve stem hole, the bolt holes and the center hole in the central hub area is included for the purpose of illustrating environmental subject matter and forms no part of the claimed design.

**1 Claim, 2 Drawing Sheets**

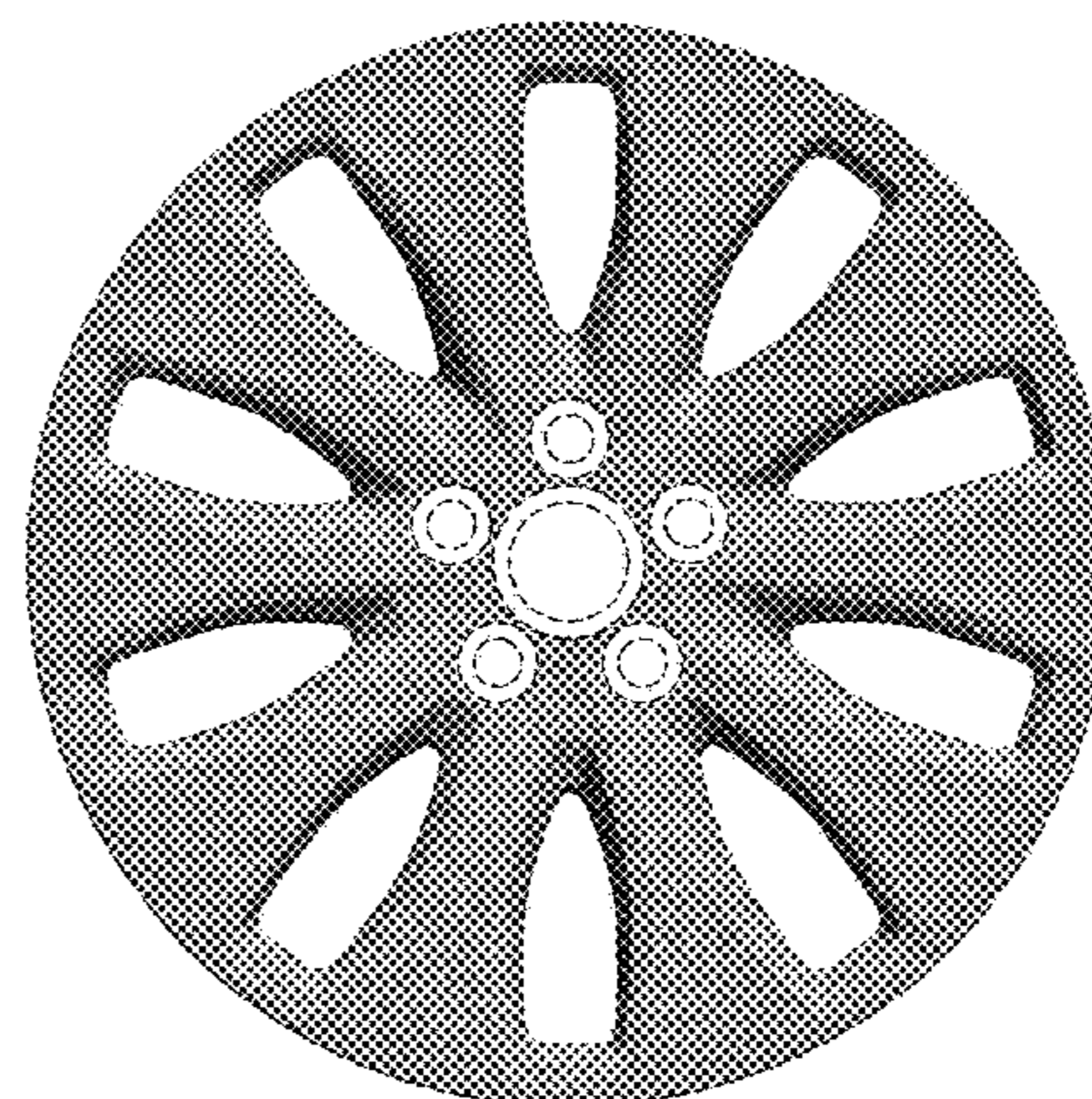
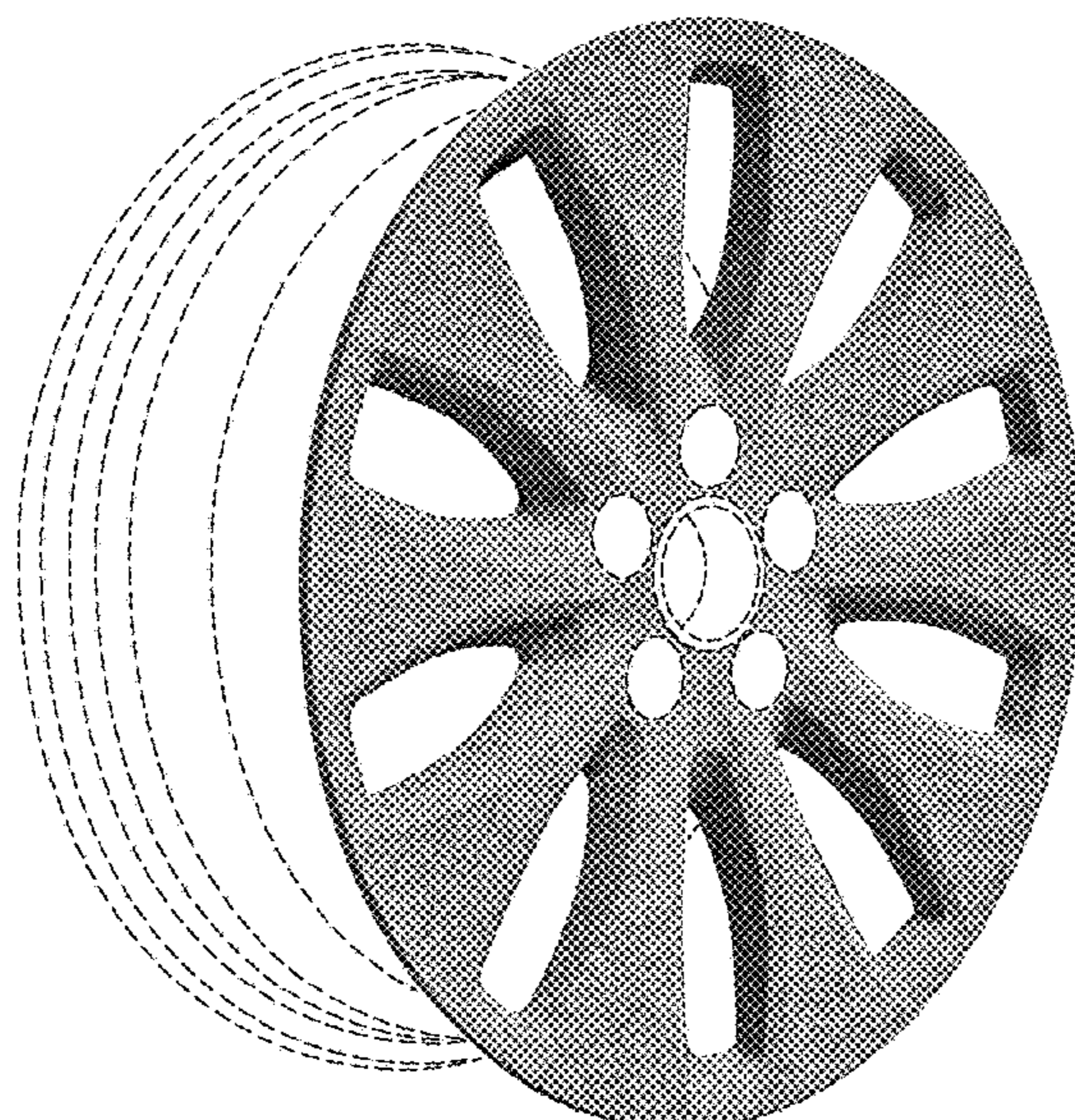

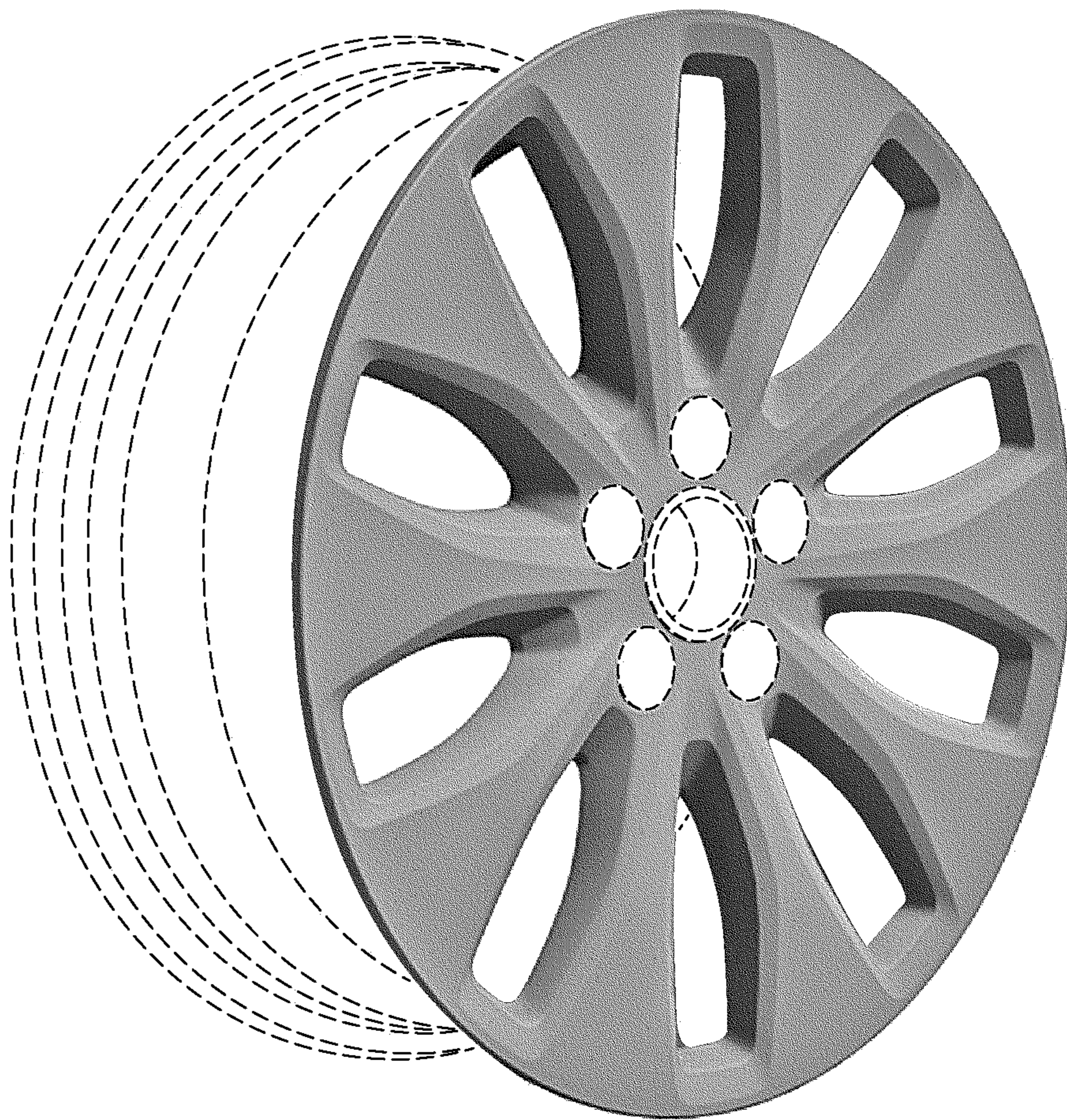

FIG. 1

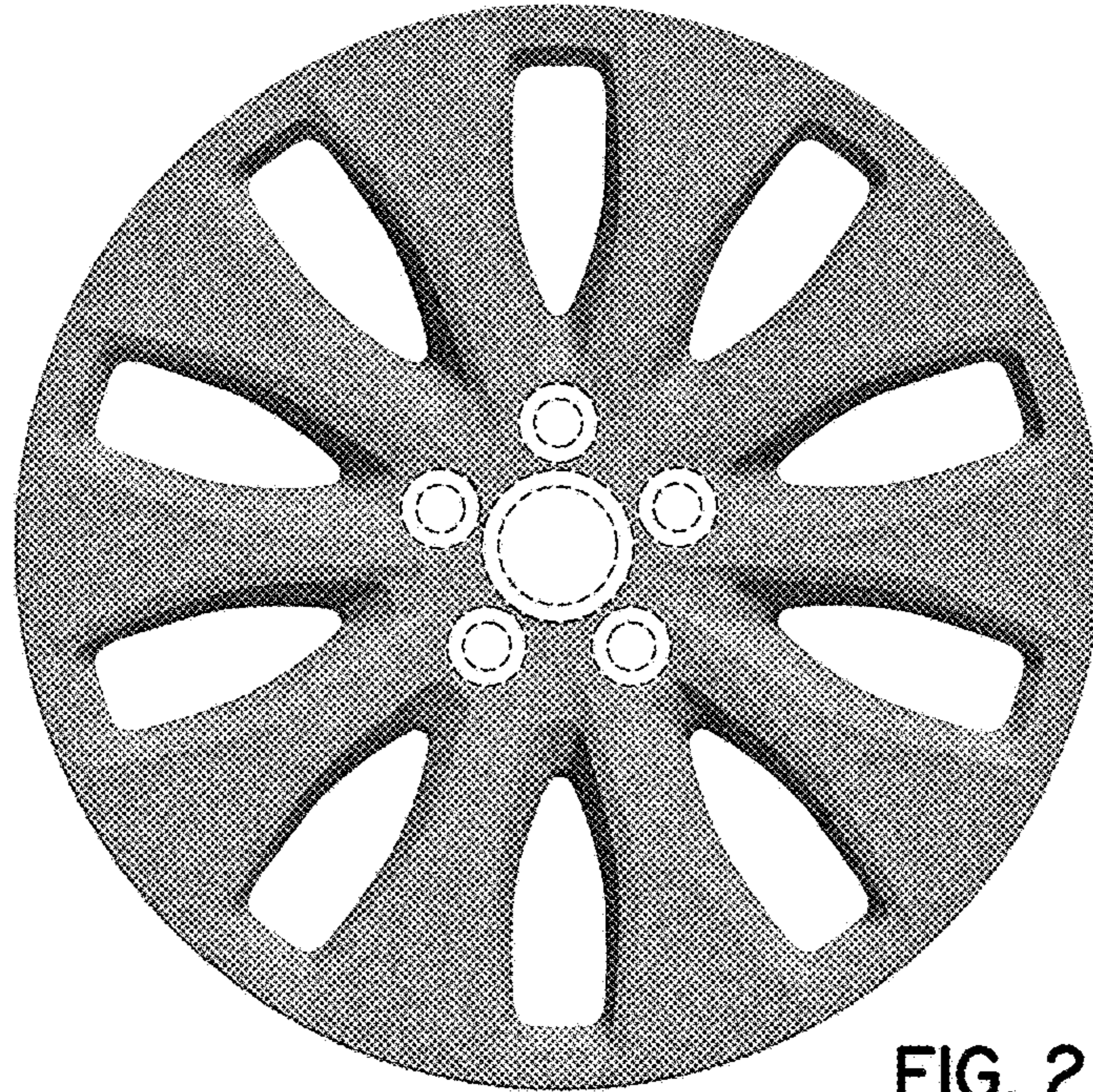

FIG. 2

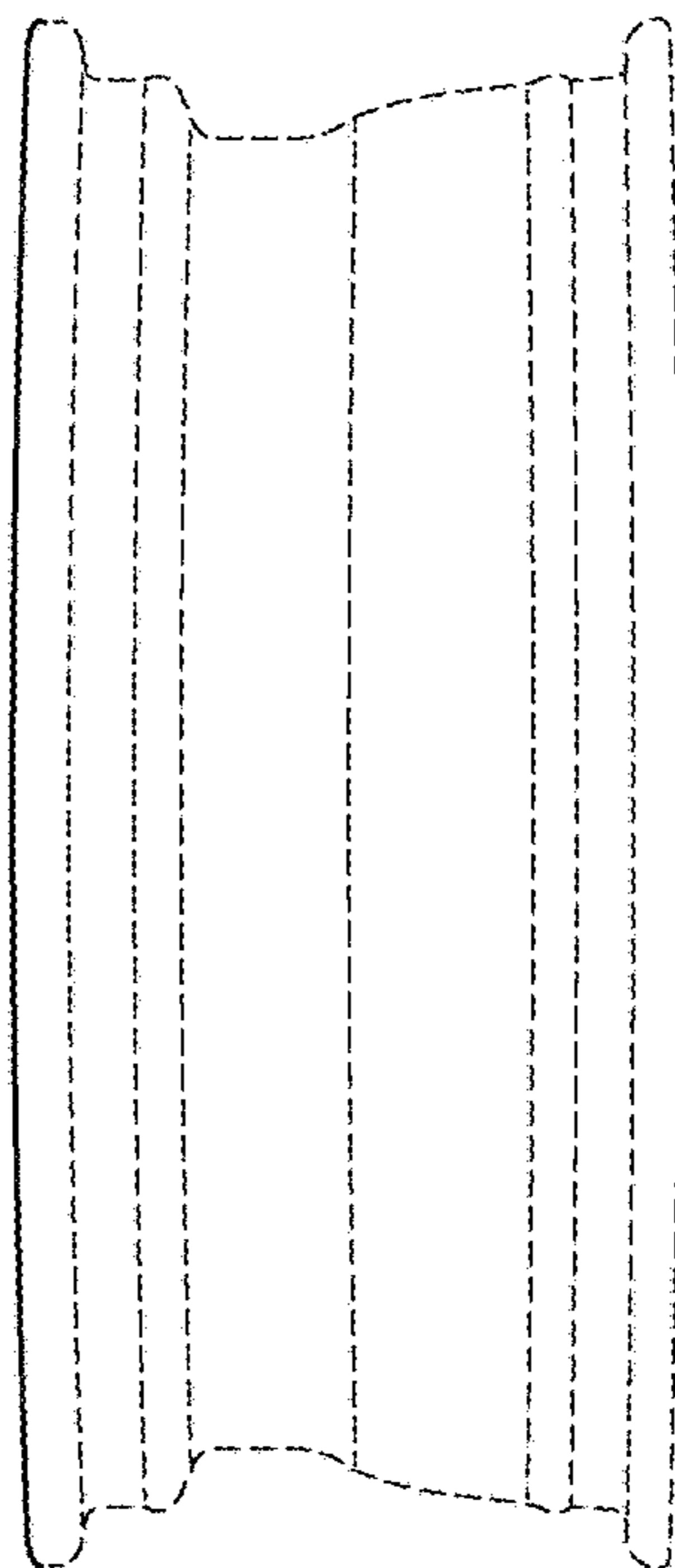

FIG. 3