



US00D790331S

(12) **United States Design Patent**
Baiz et al.

(10) **Patent No.:** **US D790,331 S**
(45) **Date of Patent:** **** Jun. 27, 2017**

(54) **BULLET BOLT WITH CUP WASHER**

(71) Applicant: **ESR PERFORMANCE CORP**,
Miami, FL (US)
(72) Inventors: **Enrique J Baiz**, Miramar, FL (US);
Oswaldo Izquierdo, Homestead, FL
(US)

(**) Term: **15 Years**

(21) Appl. No.: **29/562,265**

(22) Filed: **Apr. 25, 2016**

(51) **LOC (10) Cl.** **08-08**

(52) **U.S. Cl.**
USPC **D8/387**; D8/397

(58) **Field of Classification Search**
USPC D8/382, 387, 388, 391, 393, 397, 399;
D12/202, 213, 223, 400, 207, 208
CPC F16B 37/00; F16B 37/14; F16B 37/145;
F16B 35/04; F16B 35/06; F16B 41/00;
F16B 41/002; F16B 41/005; B60B 23/06;
B60B 23/08; Y10S 411/91; Y10S
411/914; Y10S 411/915; Y10T 70/5867
See application file for complete search history.

(56) **References Cited**

U.S. PATENT DOCUMENTS

1,115,307	A *	10/1914	Guffee	F16B 41/002 29/235
3,222,976	A *	12/1965	Holman	F16B 23/0061 301/35.623
D225,970	S *	1/1973	O'Donnell	D8/387
3,817,146	A *	6/1974	Scott	F16B 35/044 29/464
D268,565	S *	4/1983	Mortus	D8/397
D292,780	S *	11/1987	Galask	D11/48
D427,511	S *	7/2000	Weld	D8/397
D460,398	S *	7/2002	Berry	D12/213
D469,345	S *	1/2003	Berry	D8/382

(Continued)

OTHER PUBLICATIONS

112mm Long CNC Machined Forged Steel Extended Spike Bullet
Lug Nuts Anodized Aluminum, Image post date: Unknown, Site
visited on Dec. 21, 2016, <<https://www.vmsracing.com/products/1-2-20-112mm-long-cnc-machined-forged-steel-extended-lug-nuts-with-anodized-aluminum-bullet-spike?variant=21693370497>>.*

(Continued)

Primary Examiner — Sandra Snapp

Assistant Examiner — Ieisha Price

(74) *Attorney, Agent, or Firm* — Quickpatents, LLC;
Kevin Prince

(57) **CLAIM**

The ornamental design for a bullet bolt with cup washer, as shown and described.

DESCRIPTION

FIG. 1 is a front view of the bullet bolt with cup washer showing our new design, with the cup washer affixed to the bullet bolt. The rear, left and right side elevation views are mirror images of;

FIG. 2 is an exploded front plan view of the bullet bolt with cup washer, showing the cup washer in an alternate position; FIG. 3 is a top, side perspective view of FIG. 1;

FIG. 4 is a second top, side perspective view of FIG. 1, showing the opposite side of FIG. 3;

FIG. 5 is a bottom, side perspective view of FIG. 1;

FIG. 6 is a second bottom, side perspective view of FIG. 1, showing the opposite side of FIG. 5;

FIG. 7 is an exploded top, side perspective view of FIG. 2;

FIG. 8 is an exploded bottom, side perspective view of FIG. 2;

FIG. 9 is a second exploded top, side perspective view of FIG. 2, showing the opposite side of FIG. 7; and,

FIG. 10 is a second exploded bottom, side perspective view of FIG. 2, showing the opposite side of FIG. 8.

1 Claim, 5 Drawing Sheets

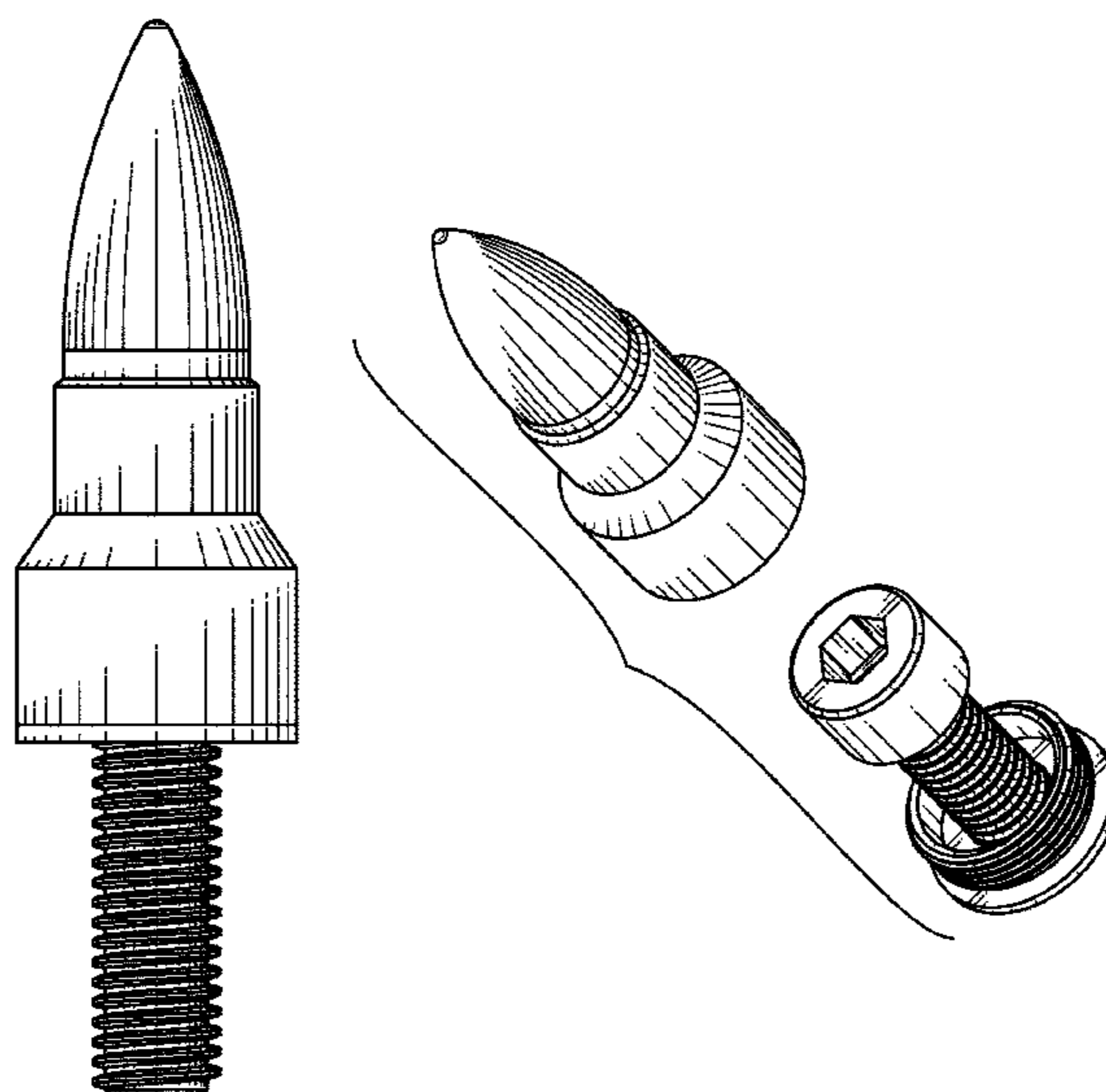

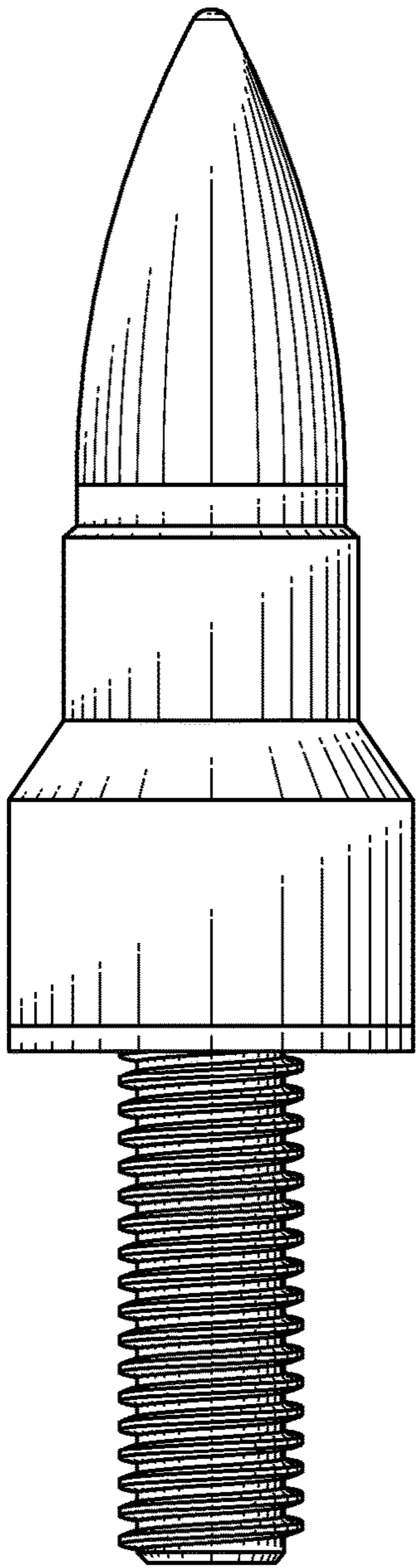

FIG. 1

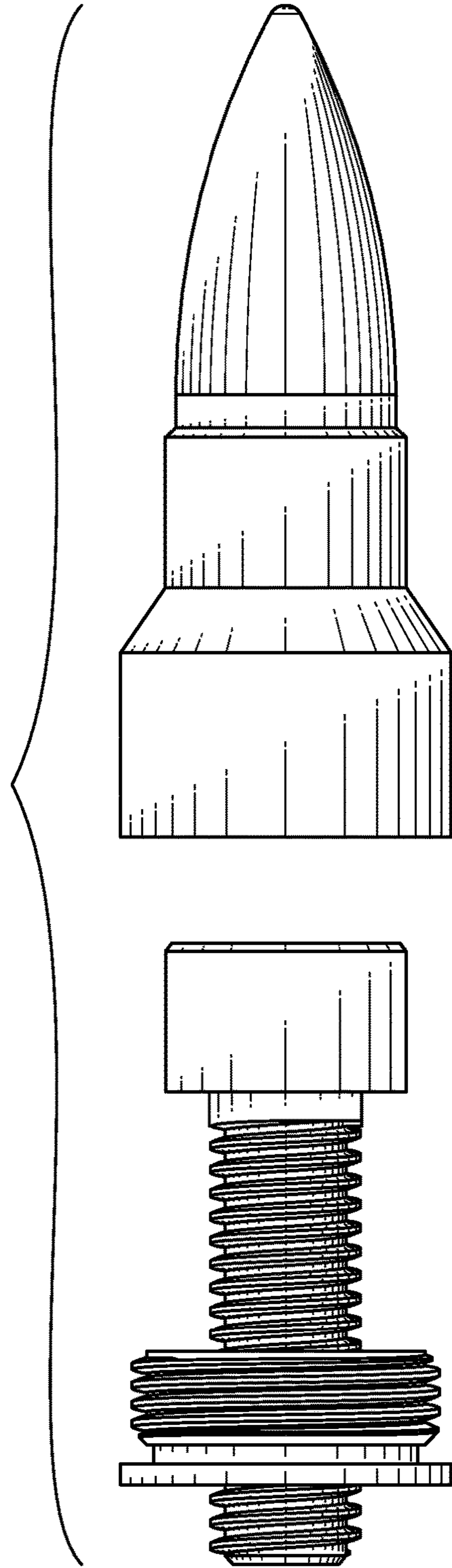

FIG. 2

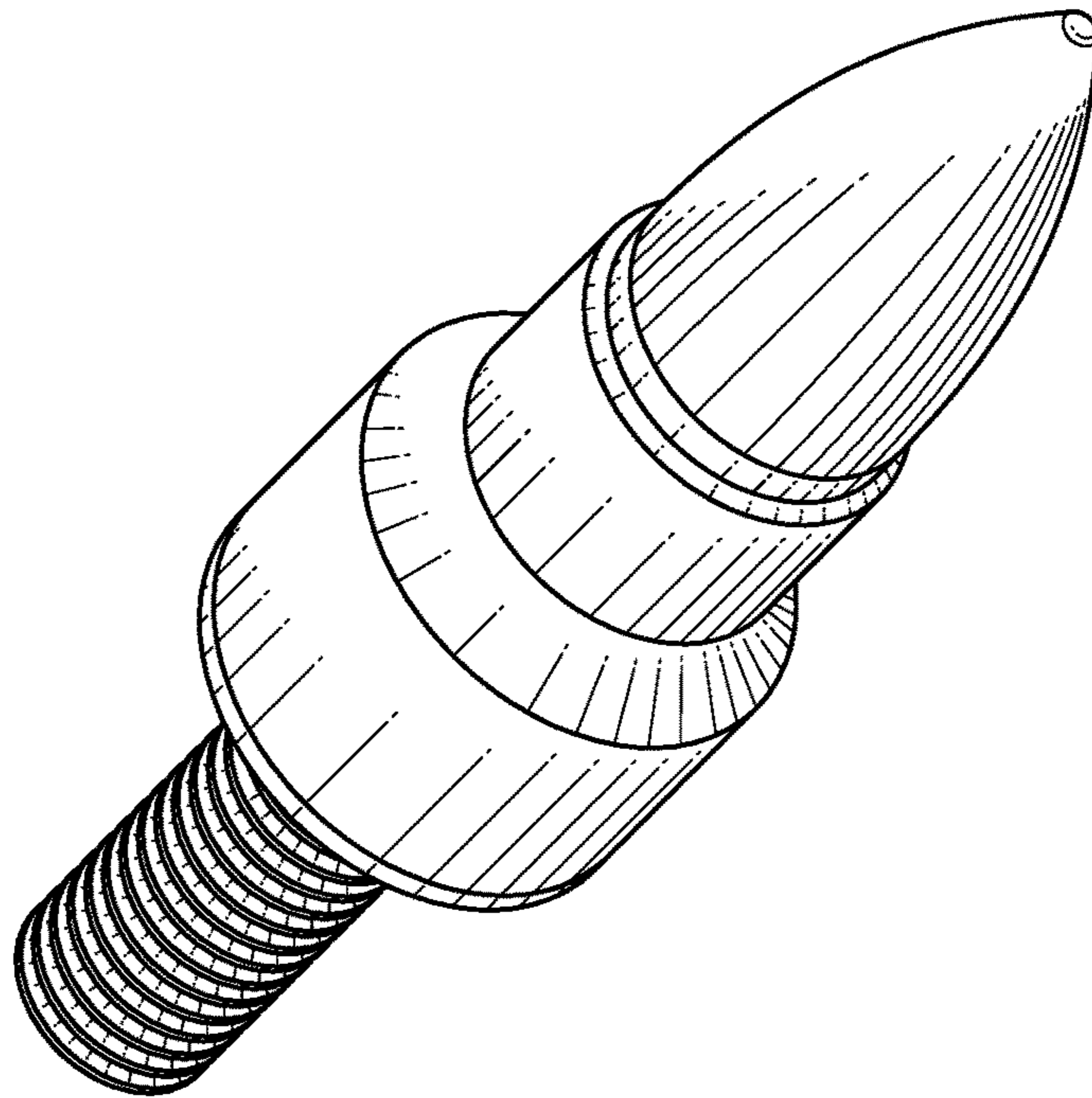

FIG. 3

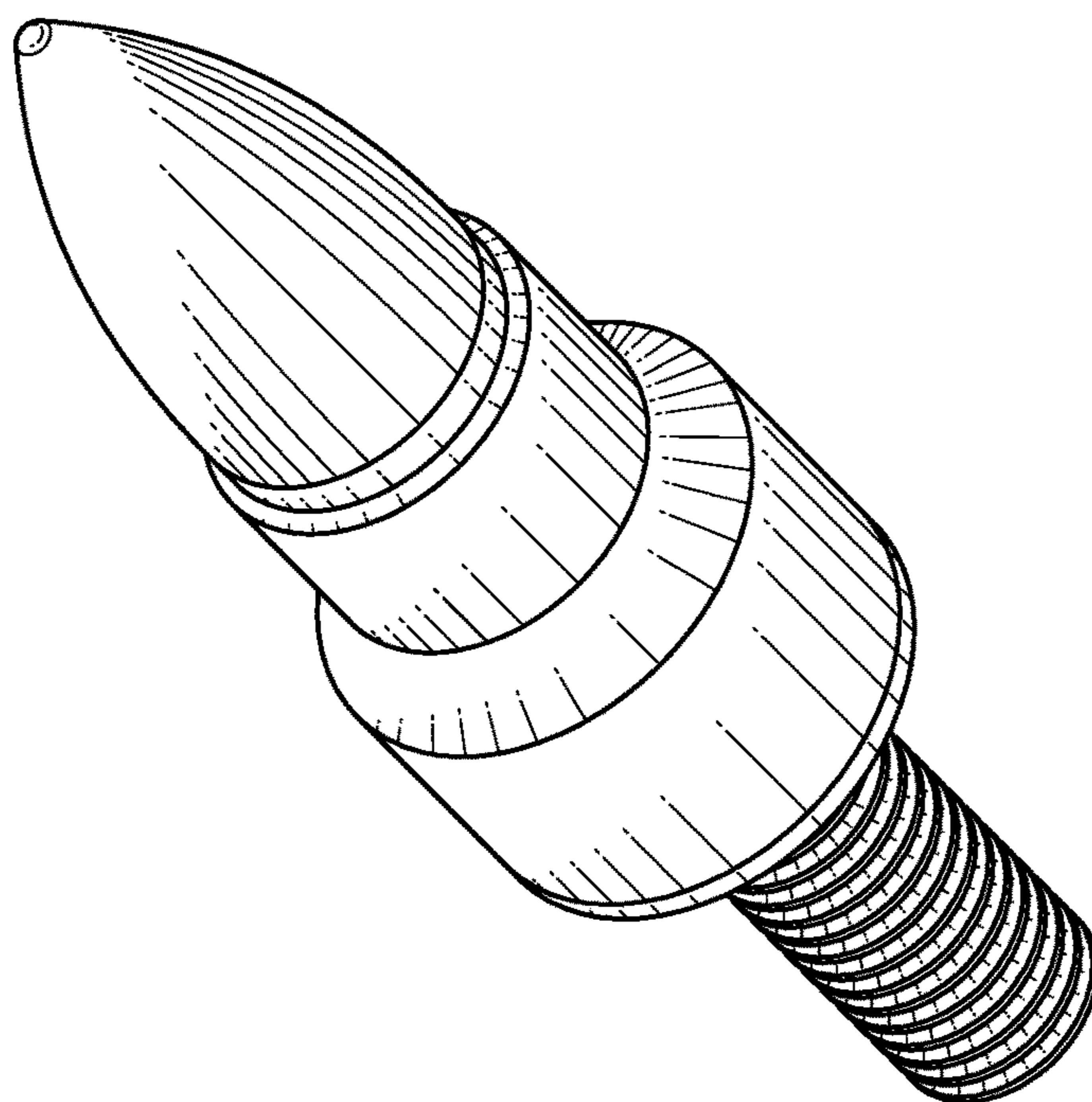

FIG. 4

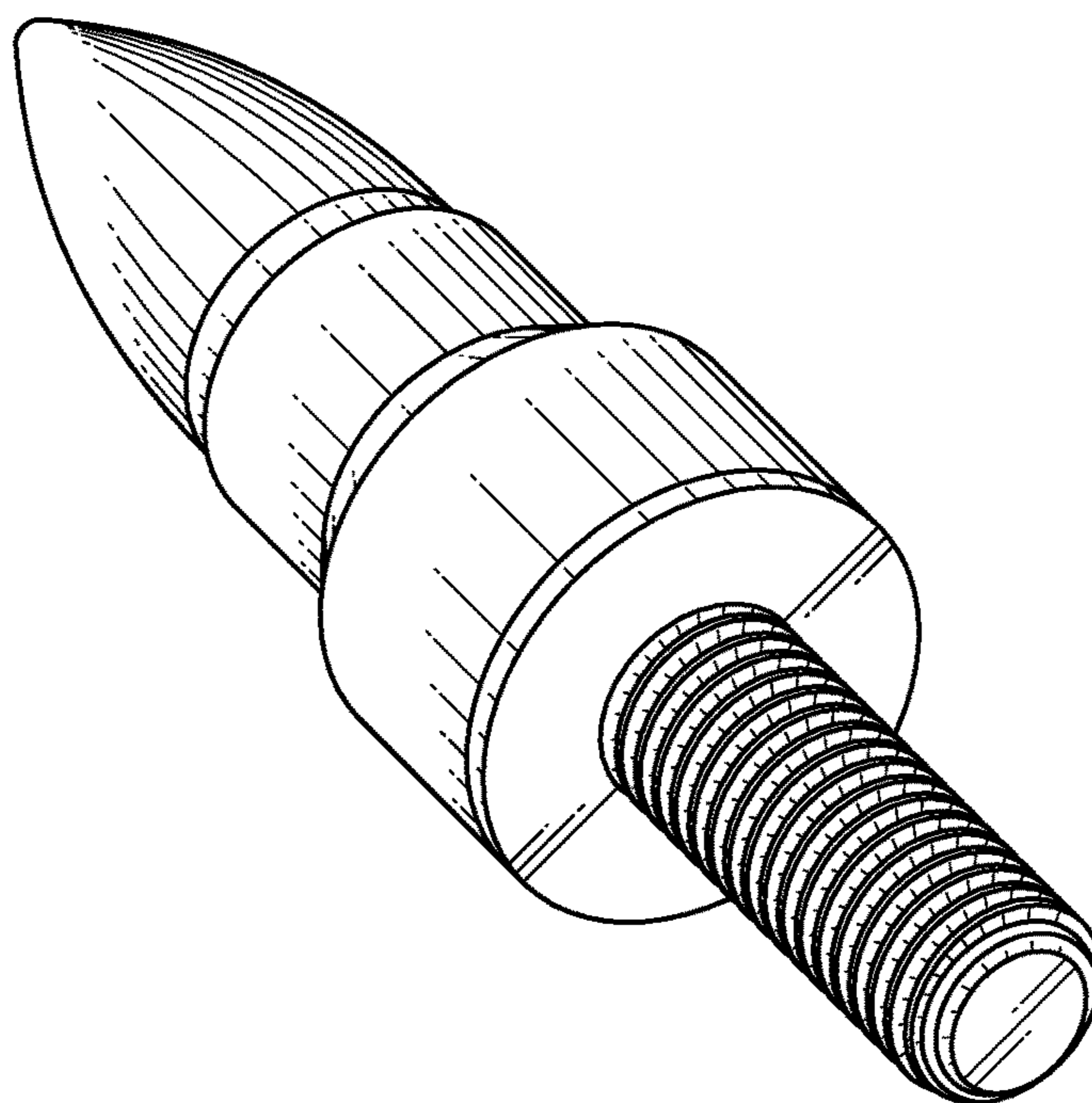

FIG. 5

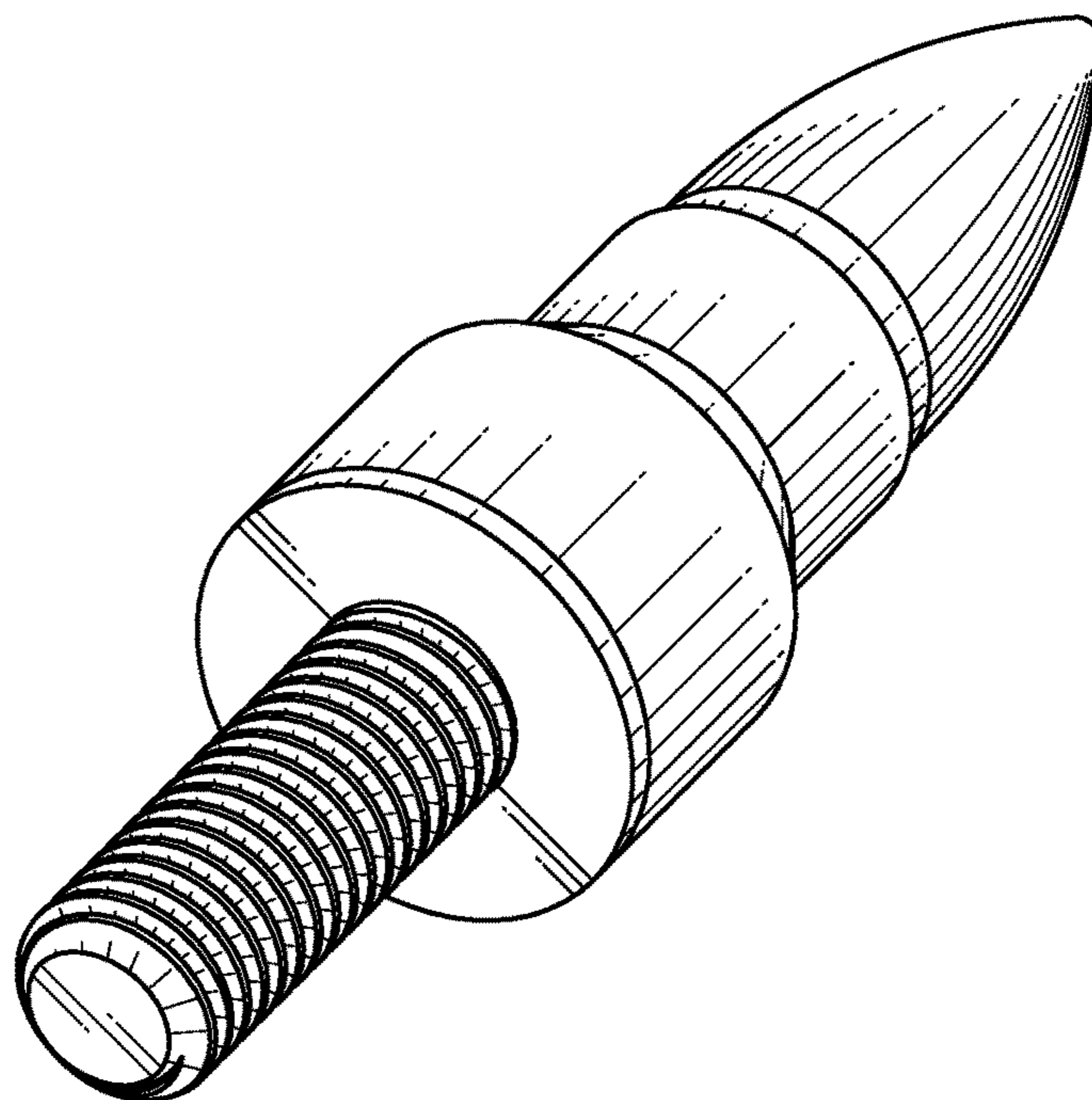

FIG. 6

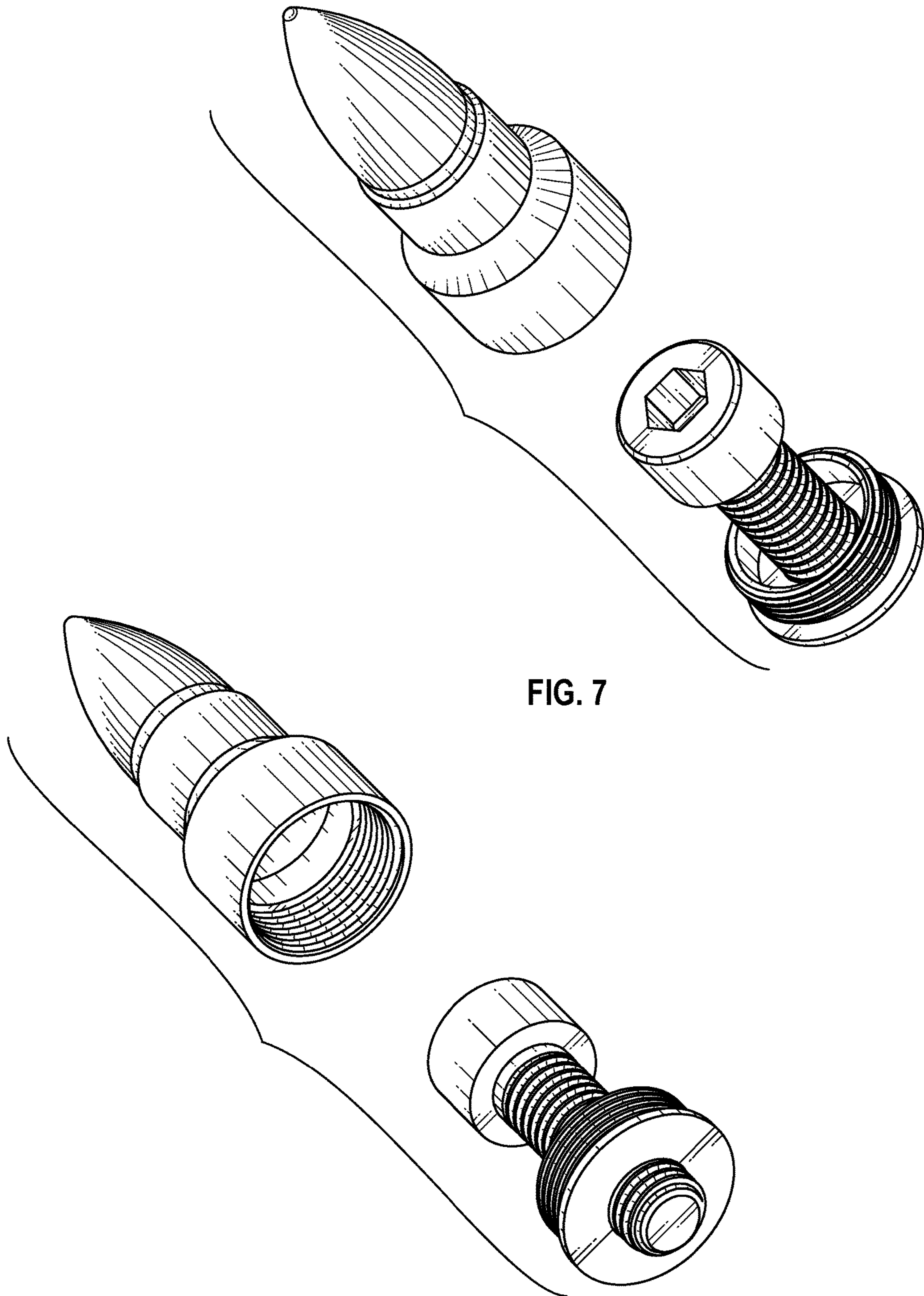

FIG. 7

FIG. 8

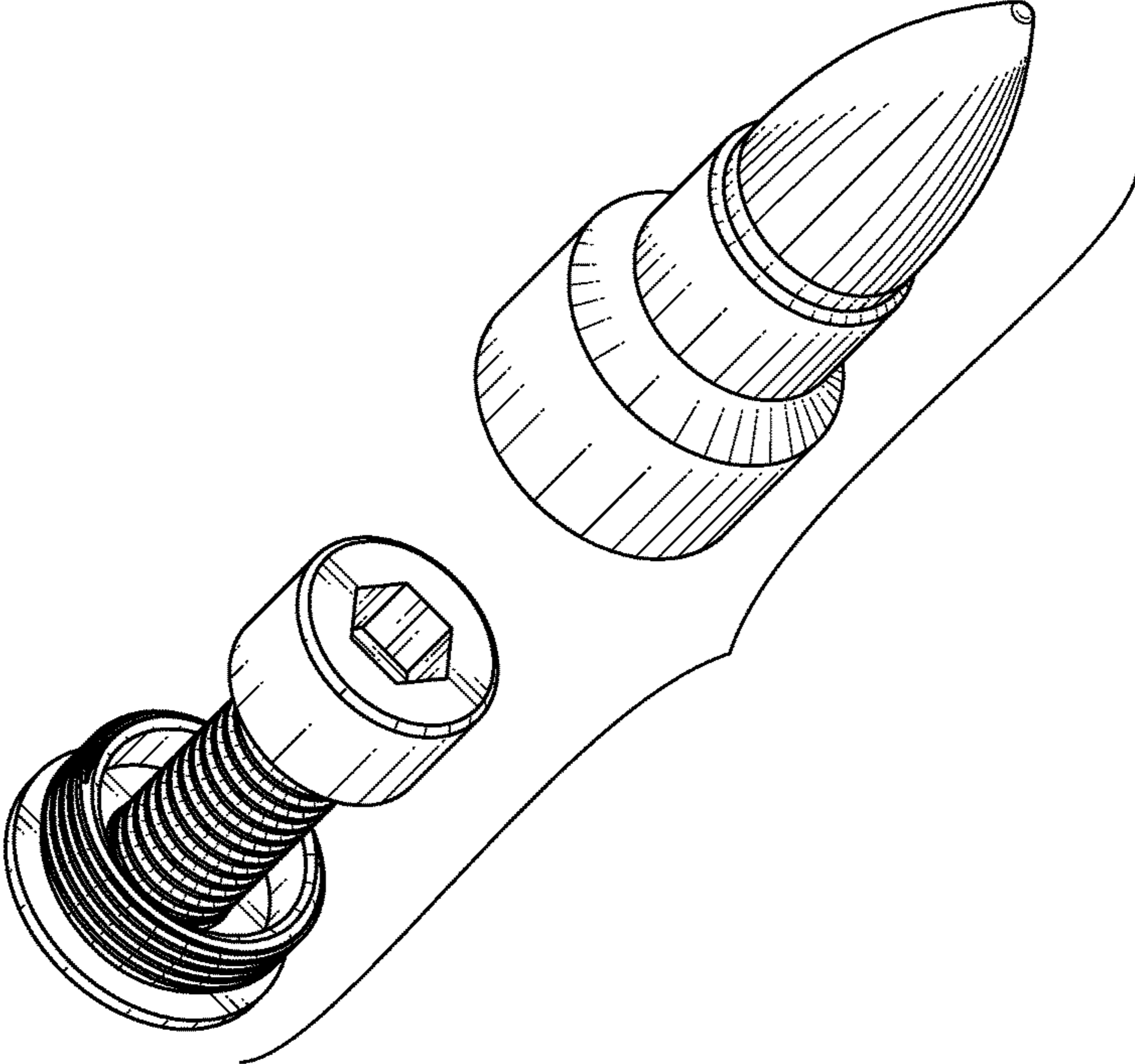

FIG. 9

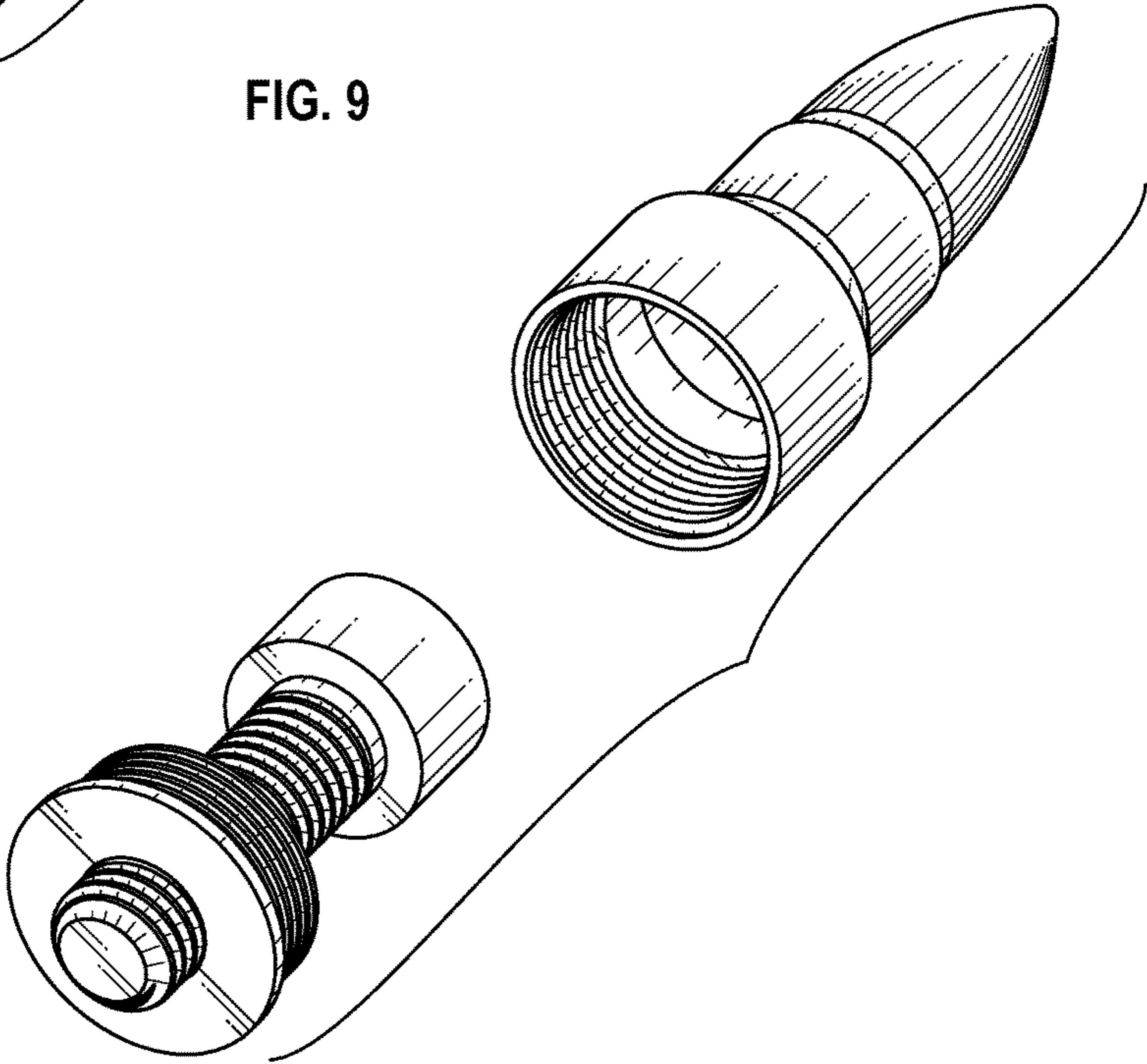

FIG. 10