



US00D790280S

(12) **United States Design Patent** (10) **Patent No.:** **US D790,280 S**  
**Hendifar et al.** (45) **Date of Patent:** **\*\* Jun. 27, 2017**

- (54) **VESSEL**
- (71) Applicant: **APPARATUS LLC**, New York, NY  
(US)
- (72) Inventors: **Gabriel Hendifar**, Rhinebeck, NY  
(US); **Jeremy R. Anderson**, Rhinebeck,  
NY (US)
- (\*\*) Term: **15 Years**
- (21) Appl. No.: **29/558,080**
- (22) Filed: **Mar. 15, 2016**
- (51) **LOC (10) Cl.** ..... **07-01**
- (52) **U.S. Cl.**  
USPC ..... **D7/537; D7/524**
- (58) **Field of Classification Search**  
USPC ..... D7/522, 524, 537, 503, 509, 550.1,  
D7/553.1, 553.3, 553.4, 554.4; D30/129;  
220/592.17, 592.16  
CPC ..... A47G 33/002; A47G 33/02; A47G 23/04;  
A47G 19/22; A47G 19/2205  
See application file for complete search history.

- D460,323 S \* 7/2002 Wyche ..... D7/524  
D701,731 S \* 4/2014 McClellan ..... D7/524  
D704,002 S \* 5/2014 Gooris ..... D7/524  
D729,975 S \* 5/2015 Mehio ..... D27/162  
D760,030 S \* 6/2016 Wilson ..... D30/129

\* cited by examiner

*Primary Examiner* — Daniel Bui

*Assistant Examiner* — Andrew Kerr

(74) *Attorney, Agent, or Firm* — Gottlieb, Rackman &  
Reisman, P.C.

(57) **CLAIM**

The ornamental design for a vessel, as shown and described.

**DESCRIPTION**

FIG. 1 is a perspective view of the vessel, showing our new design;  
FIG. 2 is a front elevation view thereof, the rear elevation view being a mirror image;  
FIG. 3 is the right side elevation view, the left side elevation view being a mirror image;  
FIG. 4 is a top plan view thereof; and,  
FIG. 5 is a bottom plan view thereof.  
The vessel is shown with a symbolic break in its height. The appearance of any portion of the vessel between the break lines forms no part of the claimed design. The broken lines in FIGS. 1, 4 and 5 represent the portions of the vessel that form no part of the claimed design.

(56) **References Cited**

U.S. PATENT DOCUMENTS

- 2,143,027 A \* 1/1939 Perry ..... A47G 19/2261  
215/374  
D418,370 S \* 1/2000 Wilson ..... D7/524

**1 Claim, 4 Drawing Sheets**

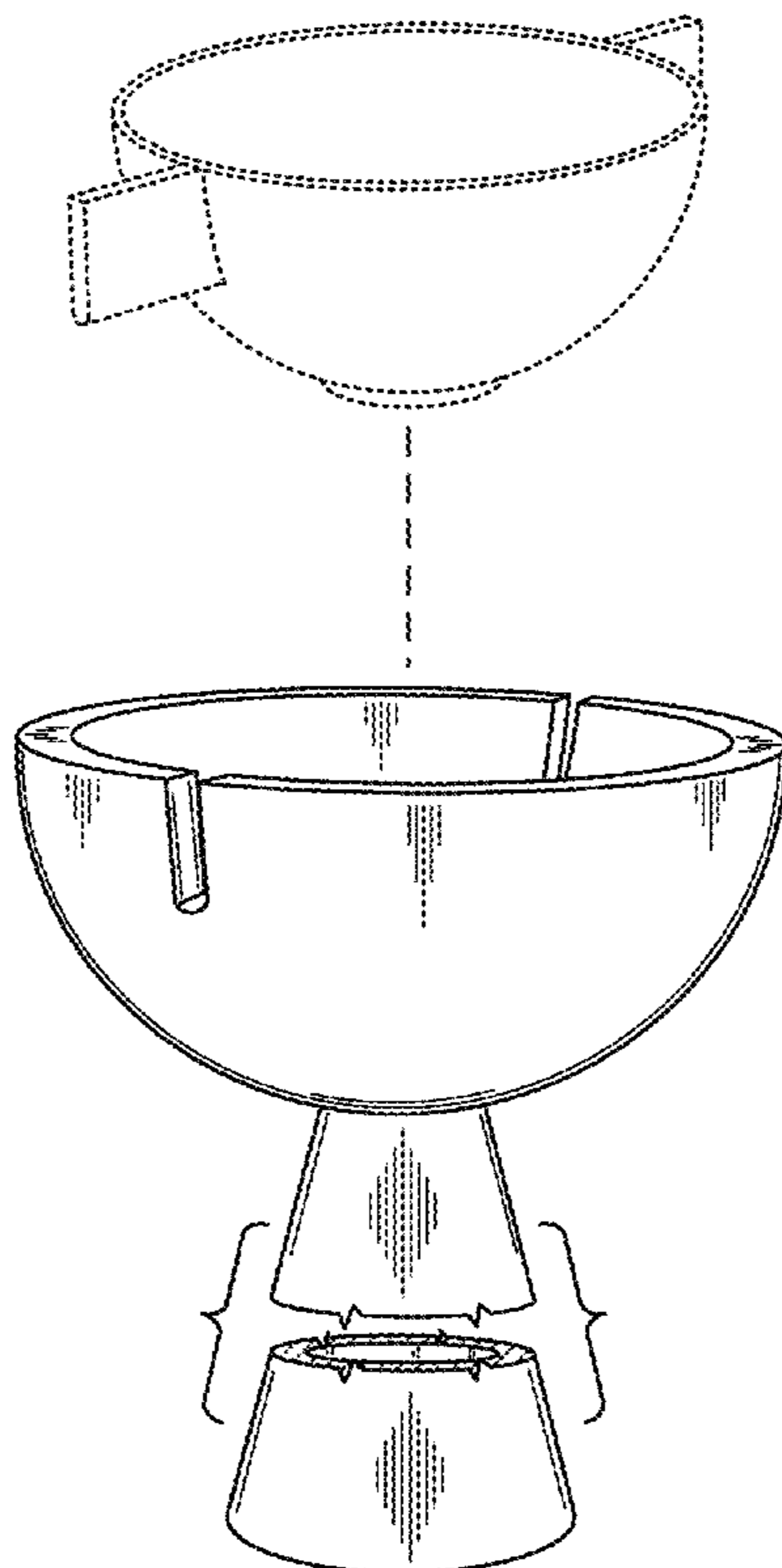

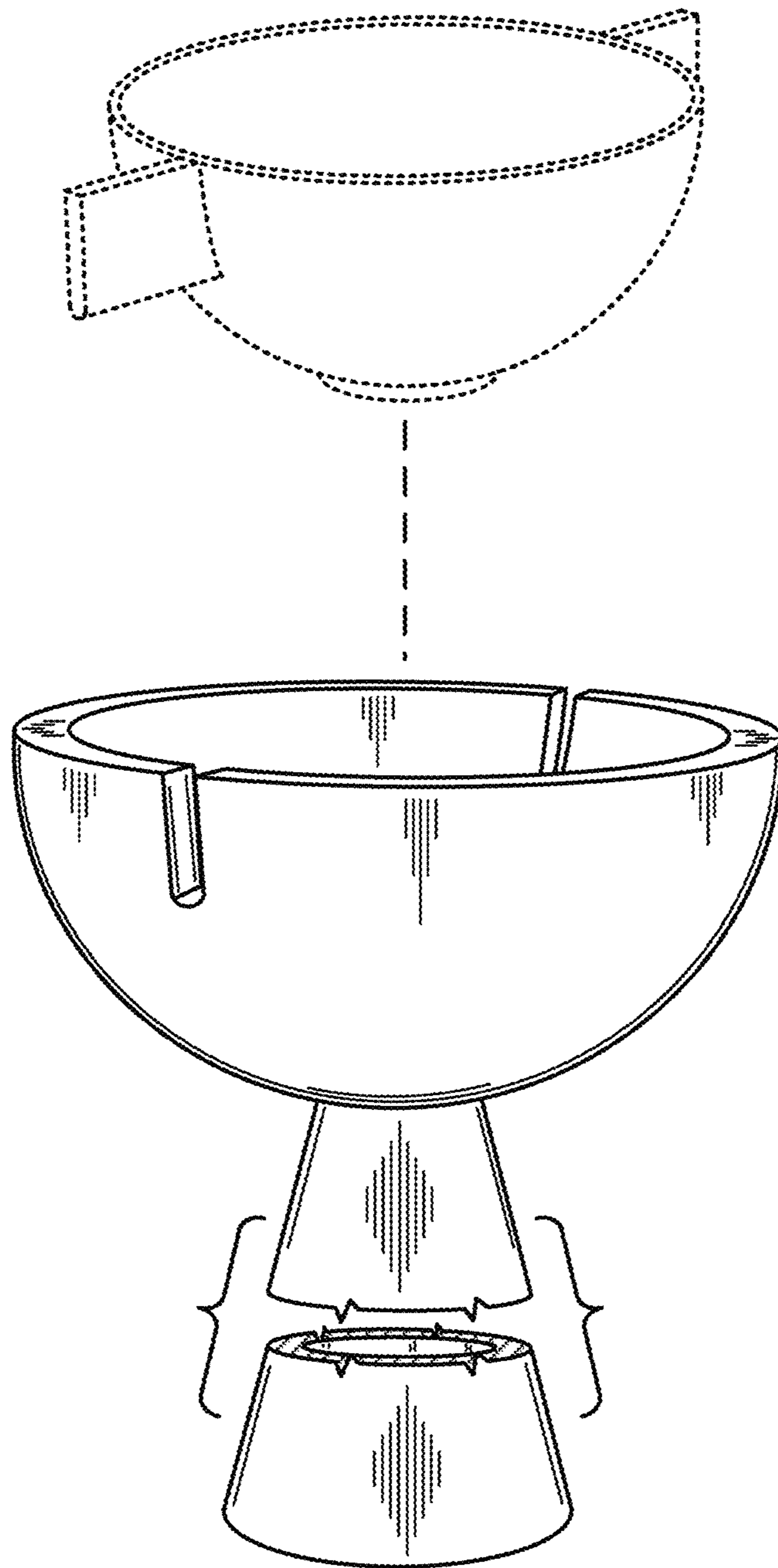

FIG. 1

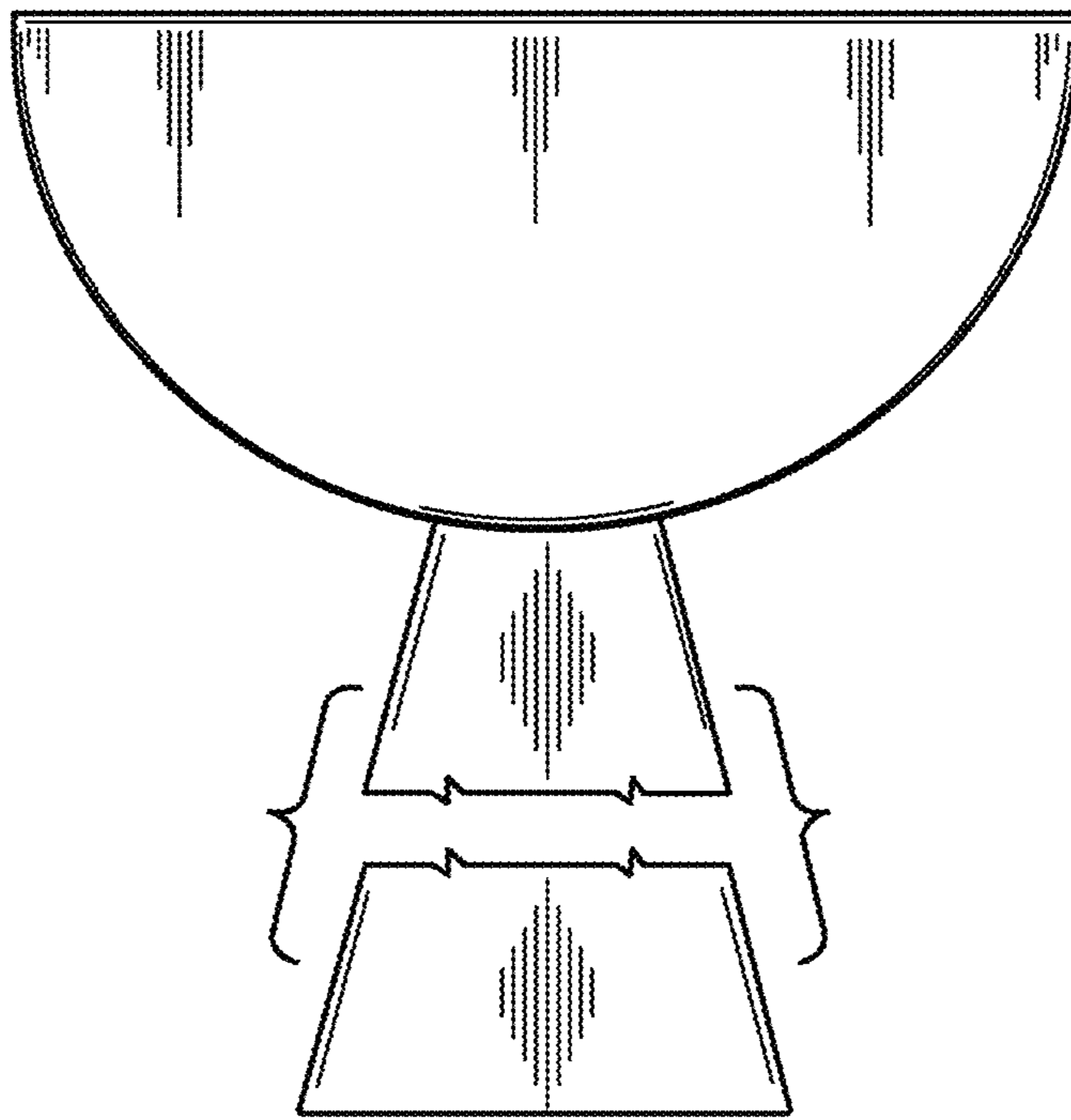

FIG. 2

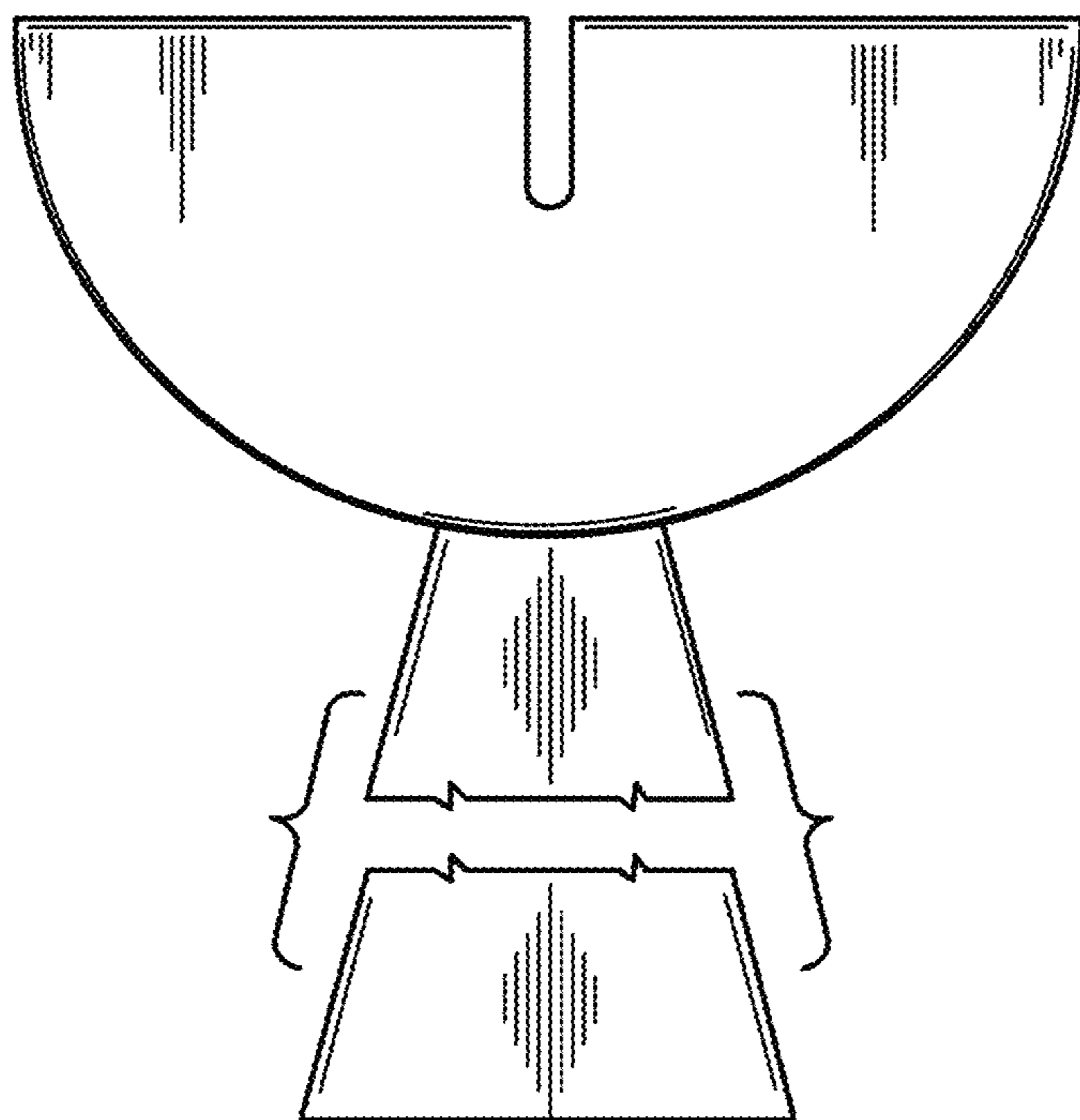

FIG. 3

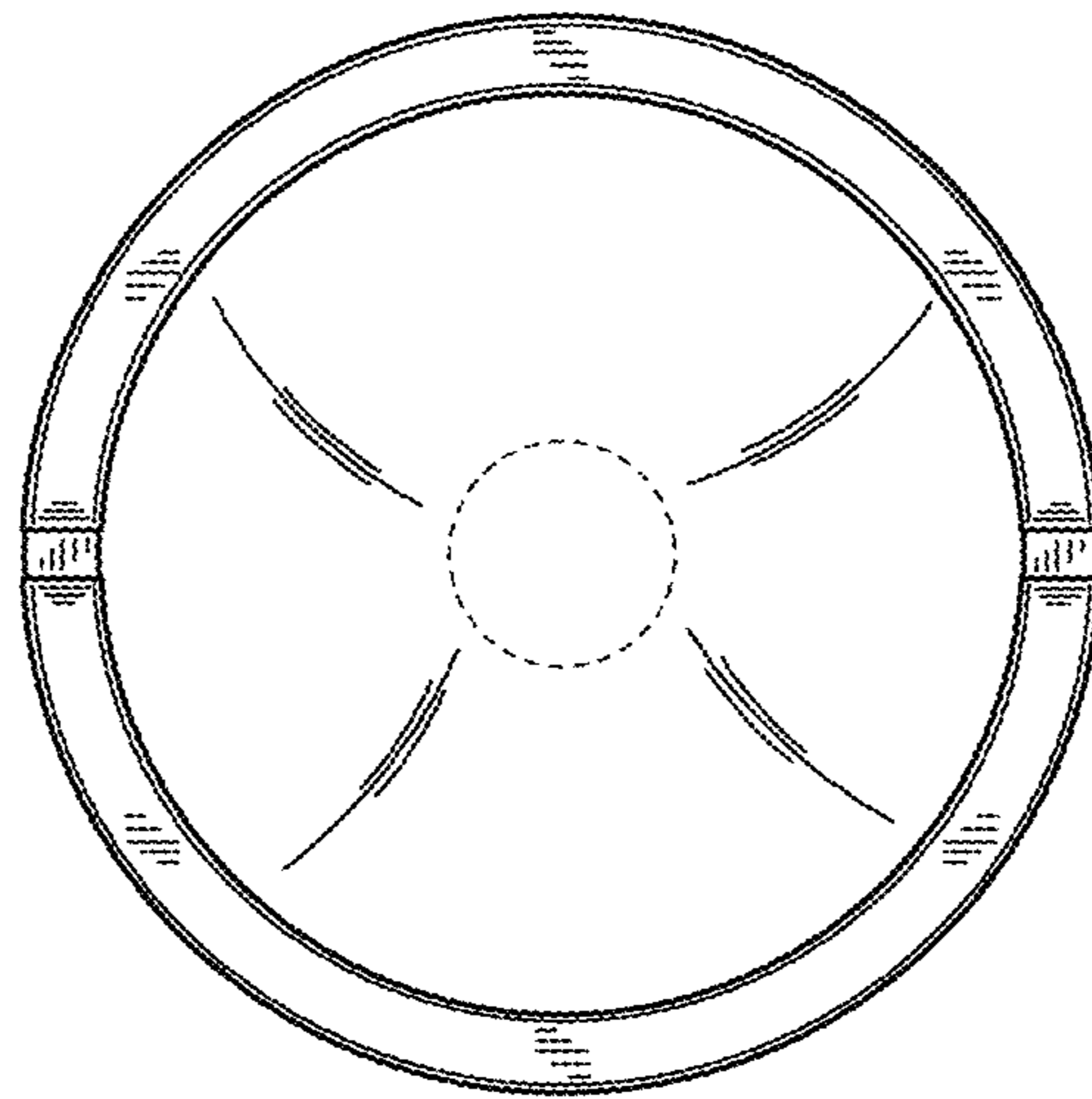

FIG. 4

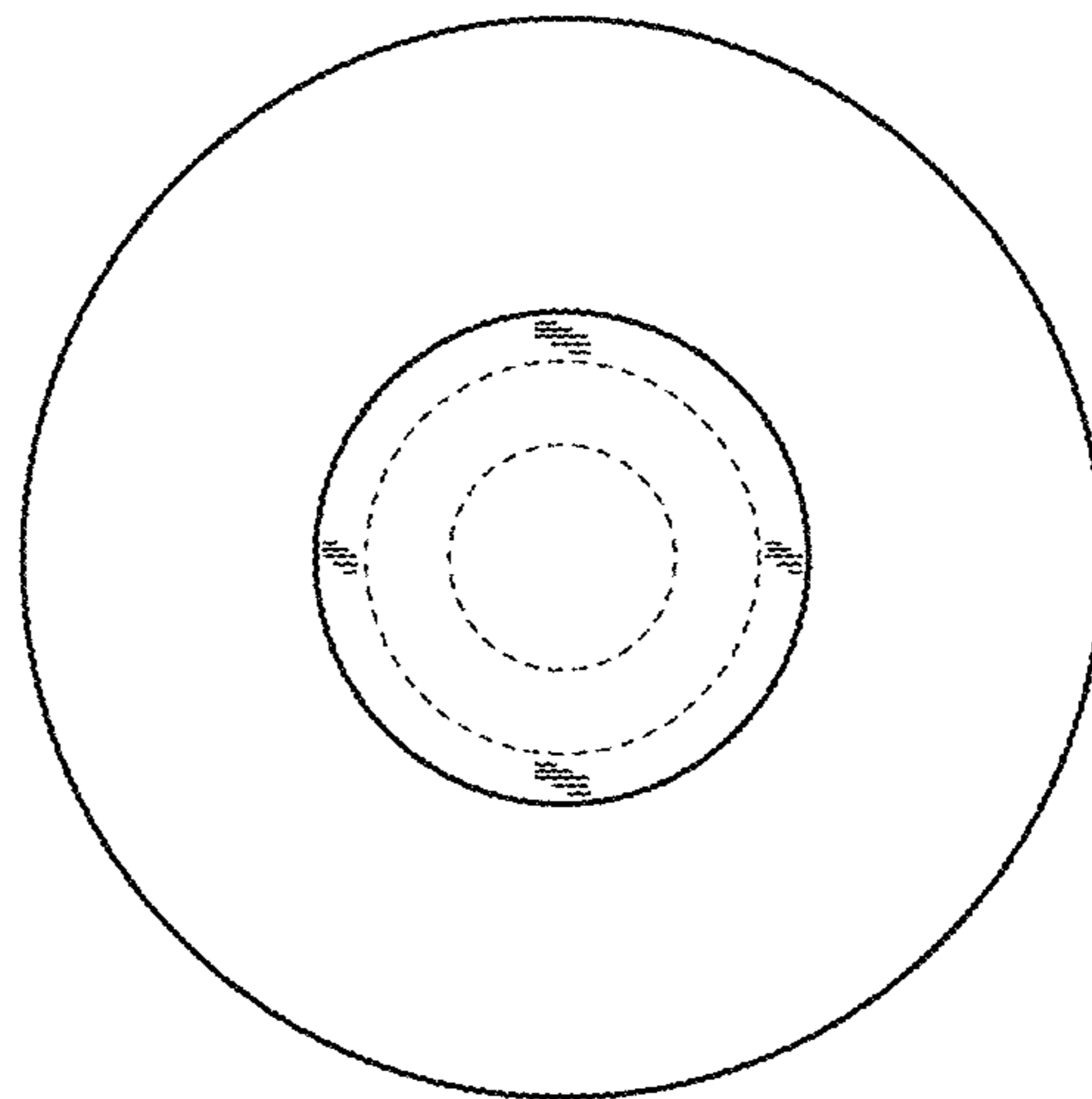

FIG. 5