



US00D790092S

(12) **United States Design Patent**  
**Conway et al.**

(10) **Patent No.:** **US D790,092 S**  
(45) **Date of Patent:** **\*\* Jun. 20, 2017**

(54) **SINGLE POD HEADLAMP**

(71) Applicants: **Scott M. Conway**, Flower Mound, TX (US); **Derek S. Sancer**, Corinth, TX (US)

(72) Inventors: **Scott M. Conway**, Flower Mound, TX (US); **Derek S. Sancer**, Corinth, TX (US)

(73) Assignee: **PACCAR Inc**, Bellevue, WA (US)

(\*\*) Term: **15 Years**

(21) Appl. No.: **29/554,439**

(22) Filed: **Feb. 11, 2016**

(51) **LOC (10) Cl.** ..... **26-06**

(52) **U.S. Cl.**  
USPC ..... **D26/28**

(58) **Field of Classification Search**  
USPC ..... D26/28–36; 362/80–83, 267–269, 362/459–468, 475–478, 485–487  
CPC ..... F21S 48/00; F21S 48/10; F21S 48/115; F21S 48/225; F21S 48/1233; F21S 48/1266; F21S 48/1388; F21S 48/2268; F21V 21/04  
See application file for complete search history.

(56) **References Cited**

**U.S. PATENT DOCUMENTS**

5,539,629 A	7/1996	Chinniah et al.	
D404,689 S	1/1999	Sacco et al.	
D455,852 S *	4/2002	Sawabe .....	D26/28
D467,020 S	12/2002	Lin	
D476,759 S	7/2003	Lin	
D490,749 S	6/2004	Satou et al.	
D494,293 S	8/2004	Pfeiffer	
D498,859 S	11/2004	Kobayashi	
D499,202 S	11/2004	Tsai	
D499,822 S	12/2004	Pfeiffer	

(Continued)

**OTHER PUBLICATIONS**

“2003 Honda Accord Sedan,” Honda, U.S., 30-page brochure.

(Continued)

*Primary Examiner* — Marcus Jackson

(74) *Attorney, Agent, or Firm* — Christensen O’Connor Johnson Kindness PLLC

(57) **CLAIM**

The ornamental design for a single pod headlamp, as shown and described.

**DESCRIPTION**

FIG. 1 is a front perspective view of a single pod headlamp suitable for use on a left side of a motor vehicle according to a first embodiment of our new design;

FIG. 2 is a rear perspective view of the single pod headlamp of FIG. 1;

FIG. 3 is a front elevational view of the single pod headlamp of FIG. 1;

FIG. 4 is a rear elevational view of the single pod headlamp of FIG. 1;

FIG. 5 is a top plan view of the single pod headlamp of FIG. 1;

FIG. 6 is a bottom plan view of the single pod headlamp of FIG. 1;

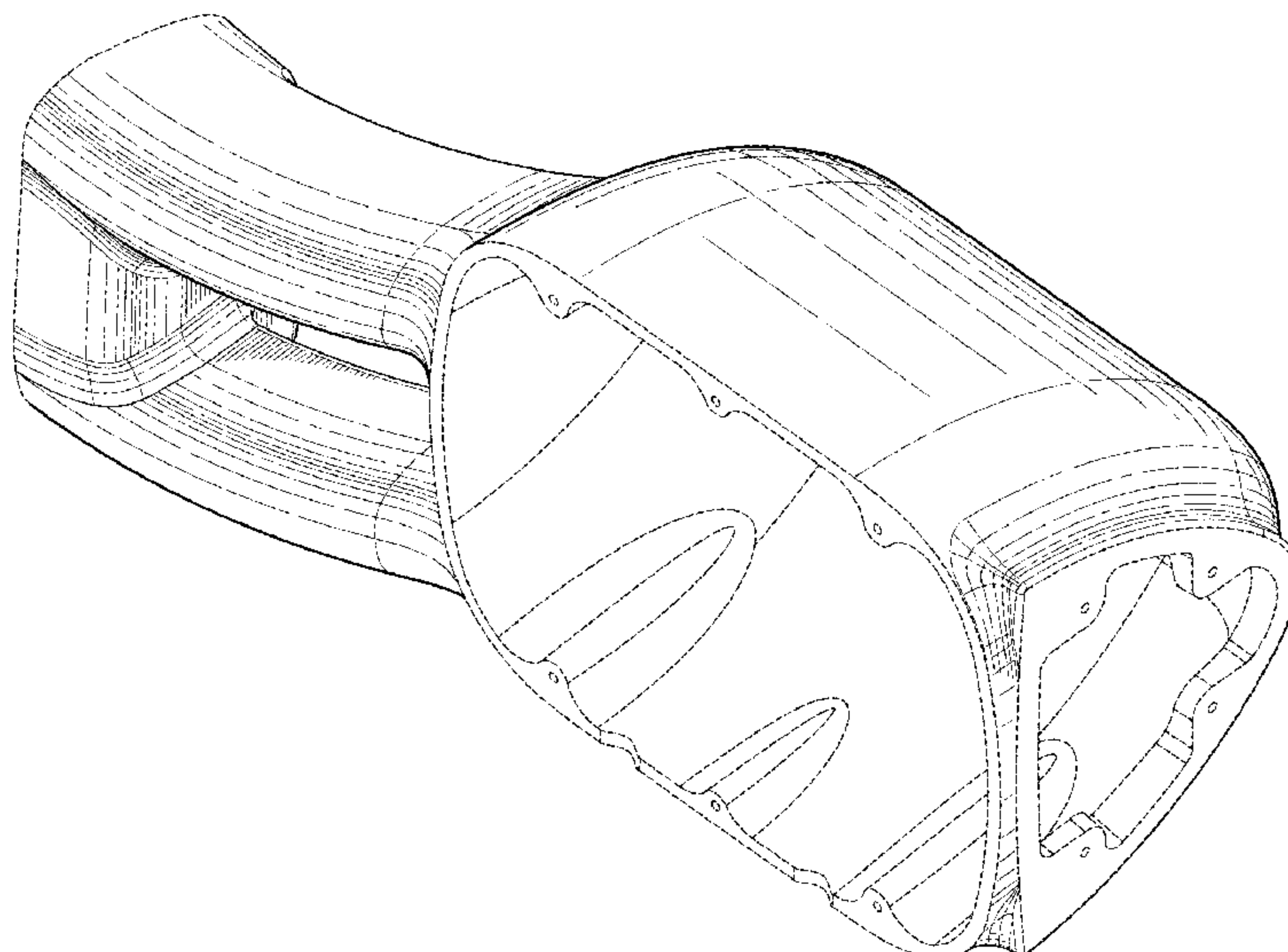
FIG. 7 is a right side elevational view of the single pod headlamp of FIG. 1; and,

FIG. 8 is a left side elevational view of the single pod headlamp of FIG. 1.

FIGS. 1-8 illustrate a first embodiment of our novel design suitable for use on the left side of a vehicle. Our novel design also includes a second embodiment suitable for use on the right side of a vehicle, which is mirrored symmetrical to FIGS. 1-8 and therefore not separately illustrated.

The subject matter shown in broken lines is hereby disclaimed and forms no part of the claimed invention.

**1 Claim, 7 Drawing Sheets**



(56)

**References Cited**

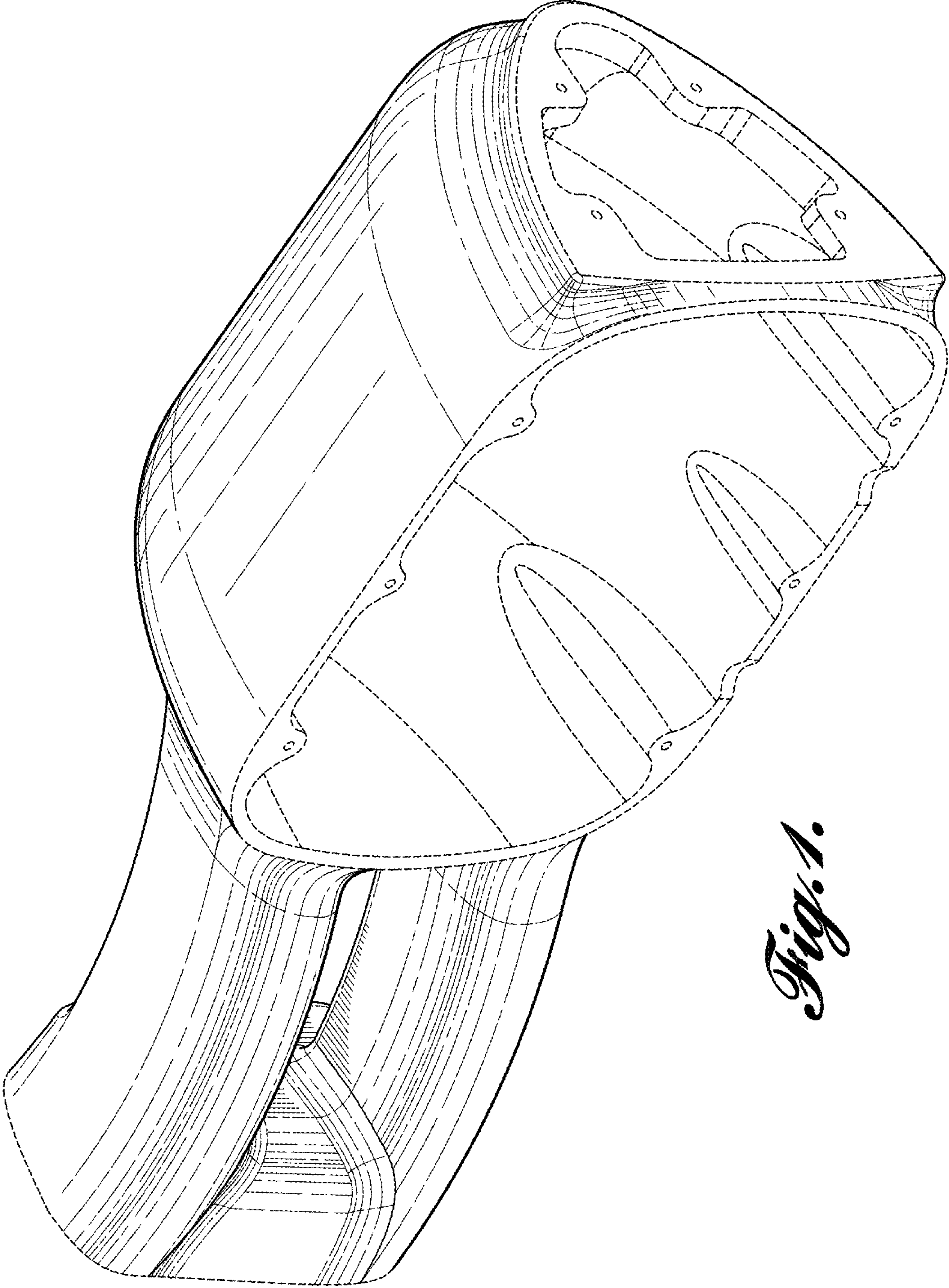
U.S. PATENT DOCUMENTS

D499,824 S	*	12/2004	Wu .....	D26/28
D501,265 S		1/2005	Lin	
D501,571 S	*	2/2005	Kouchi .....	D26/28
D506,842 S		6/2005	Nagura et al.	
D511,016 S	*	10/2005	Tamura .....	D26/28
D513,644 S		1/2006	Ruzicka et al.	
D517,708 S	*	3/2006	Phillips .....	D26/28
D544,641 S		6/2007	Elwell et al.	
D576,765 S		9/2008	Song et al.	
D595,895 S		7/2009	Lamm	
D602,184 S	*	10/2009	Wu .....	D26/28
D604,893 S		11/2009	Woolley et al.	
D608,498 S		1/2010	Beigel et al.	
D686,774 S		7/2013	McCabe et al.	

OTHER PUBLICATIONS

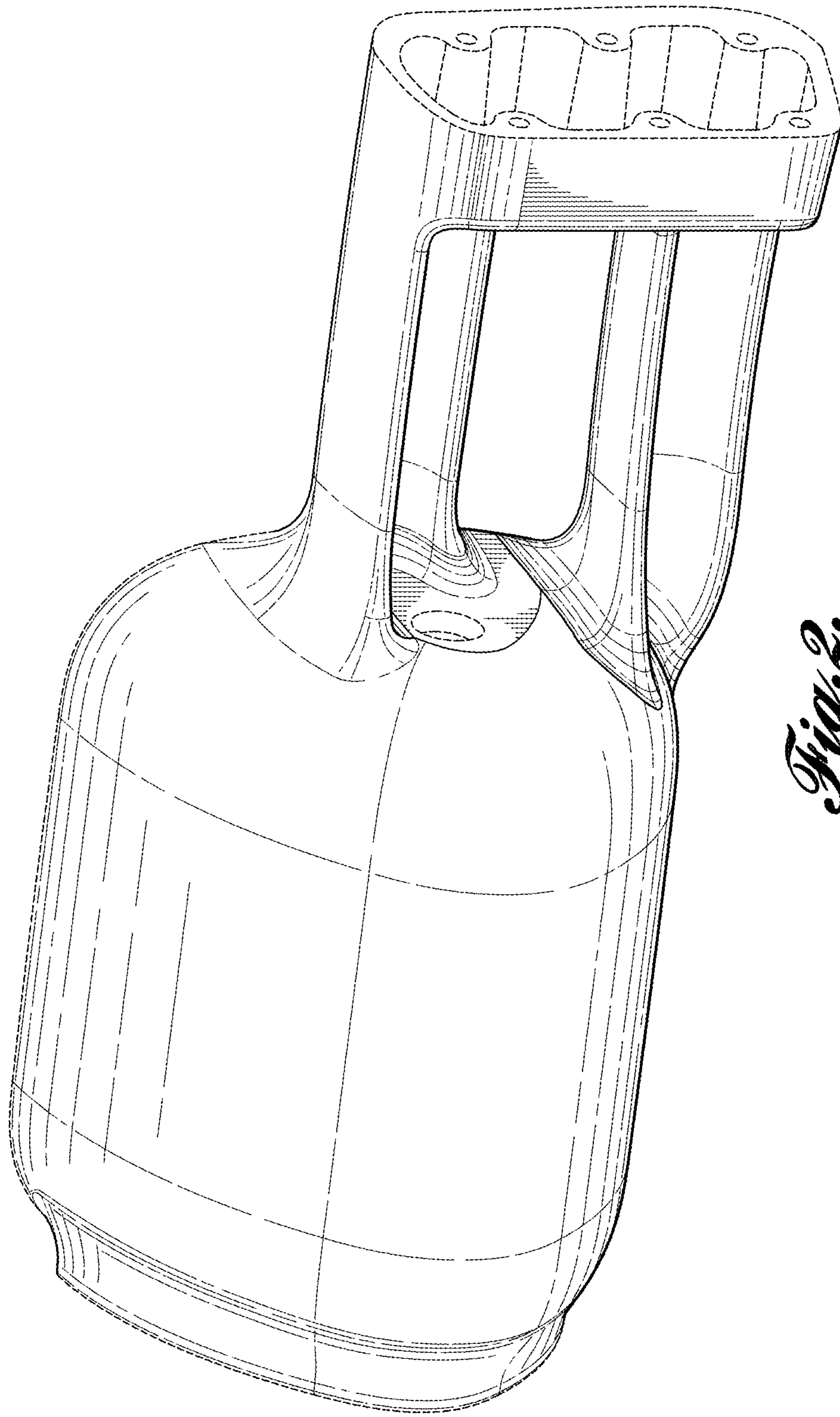
- “2003 Lexus I-S,” Lexus, U.S., 2002, 52-page brochure.
- “Freightliner Business Class® M2,” Freightliner LLC, 2003, 16-page brochure.
- “Freightliner Columbian™,” Freightliner Trucks, Portland, Oregon, 1999, 2-page brochure.
- “The New 2004 BMW 5 Series Sedan,” BMW AG, Munich, Germany, 2003, 14-page brochure.

\* cited by examiner

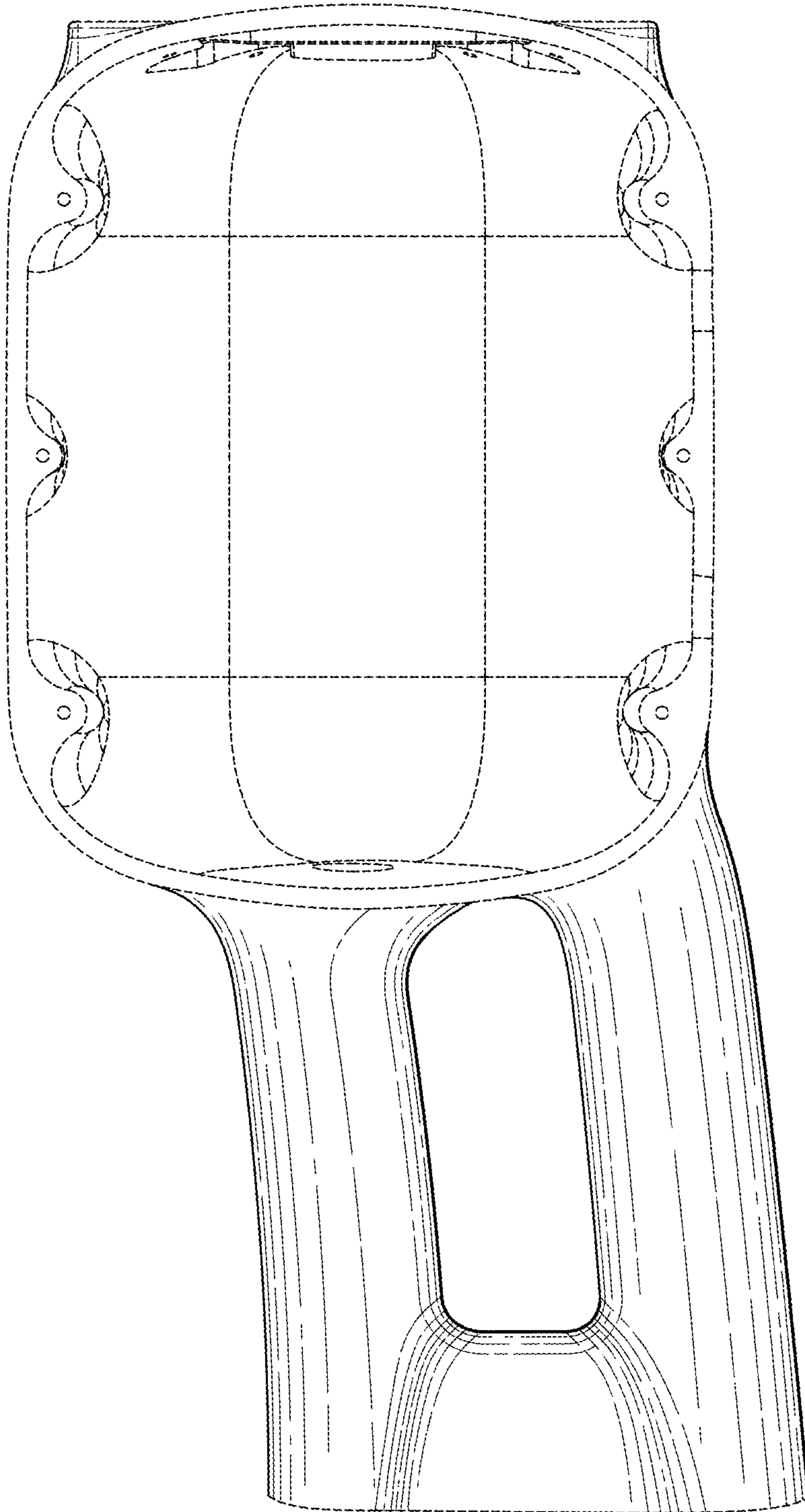


*Fig. 1.*

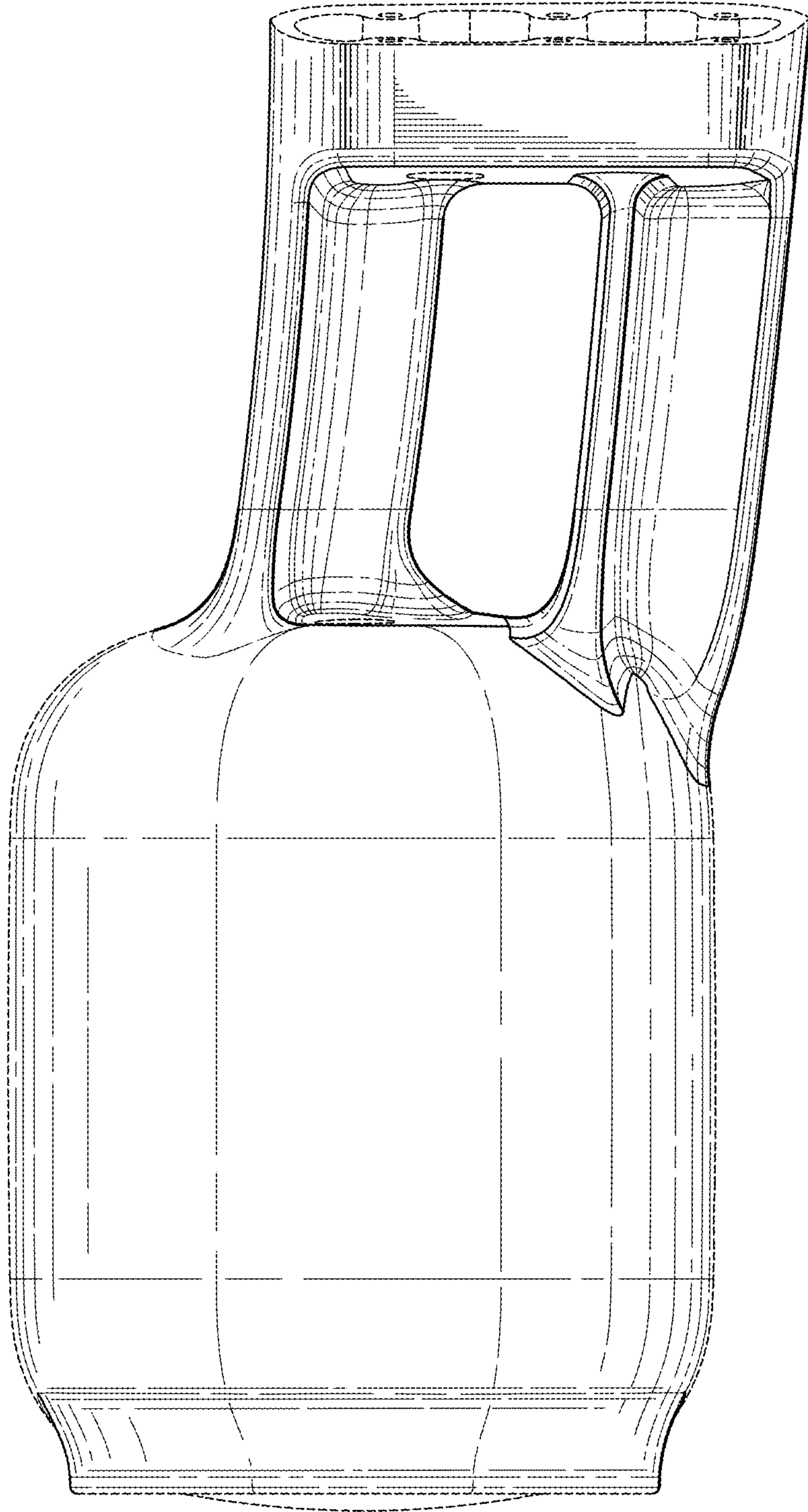




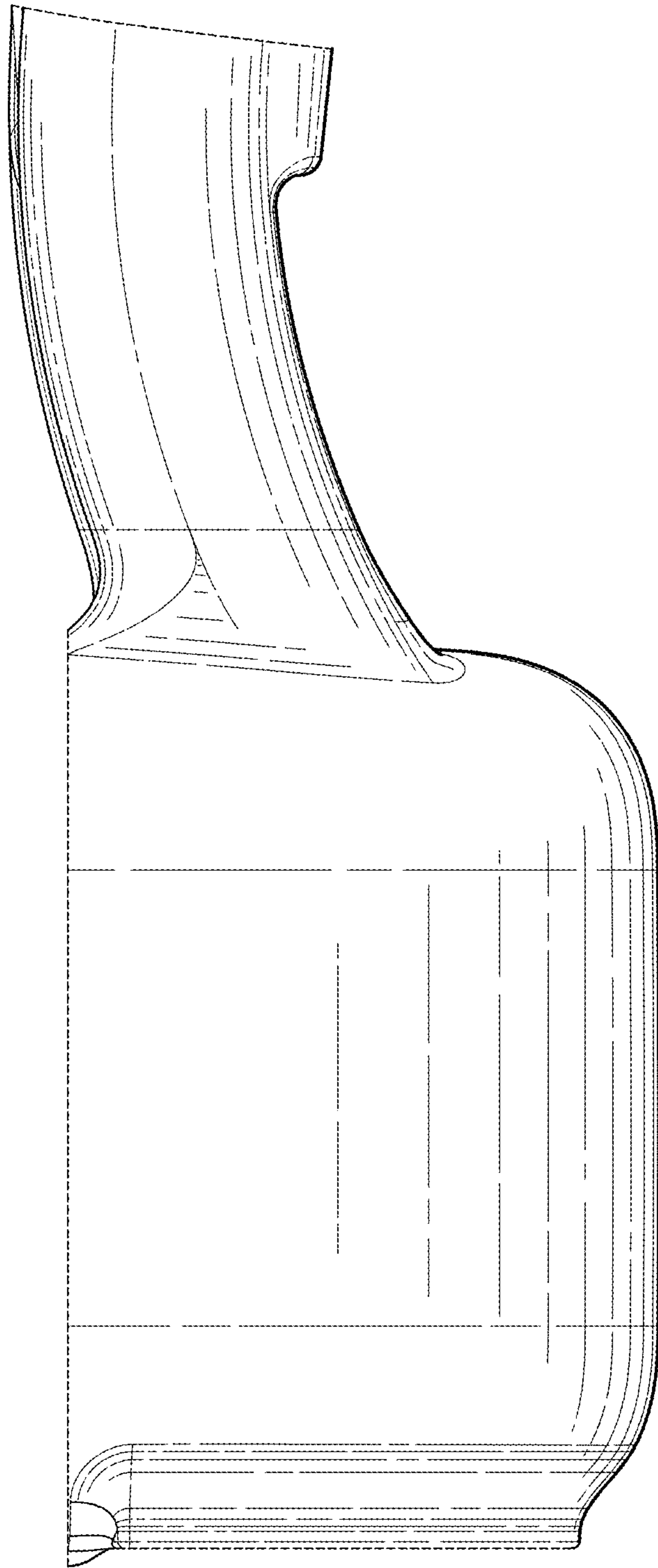
*Fig. 2.*



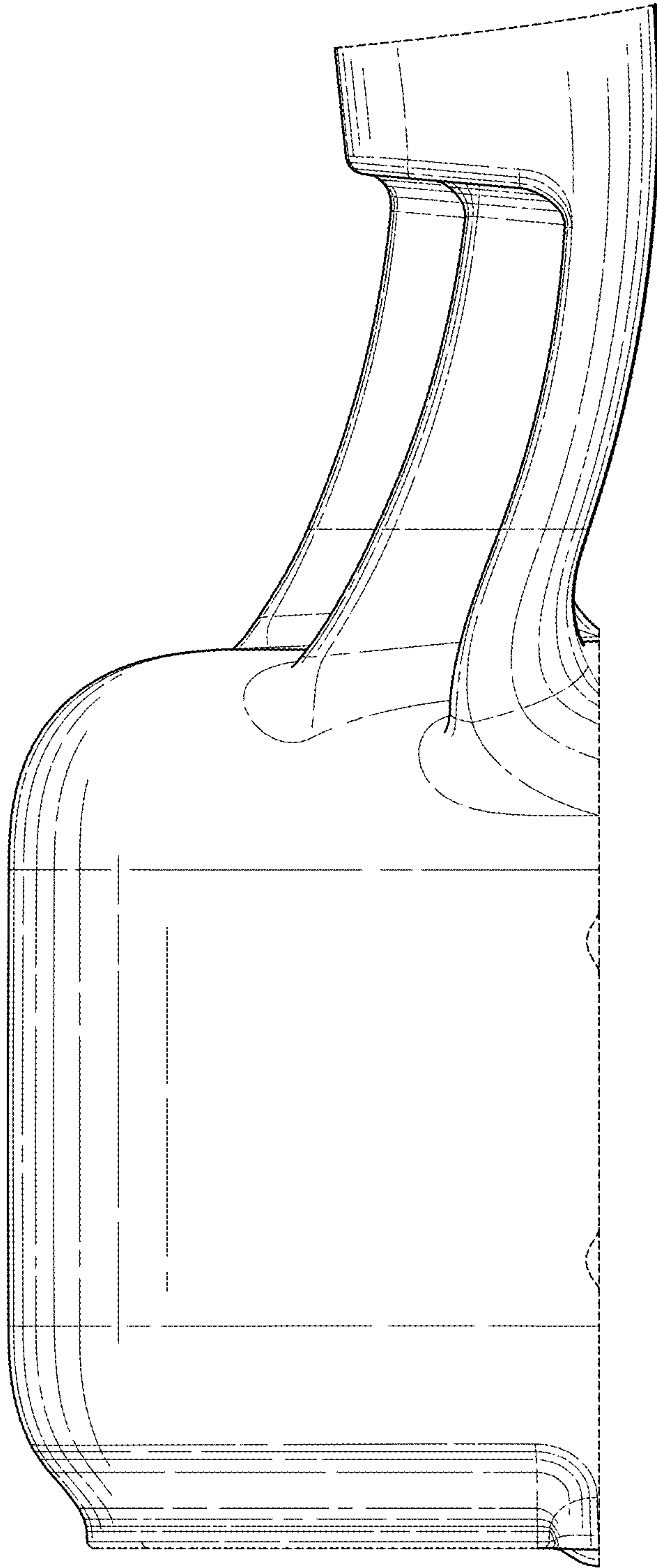
*Fig. 3.*



*Fig. 4.*



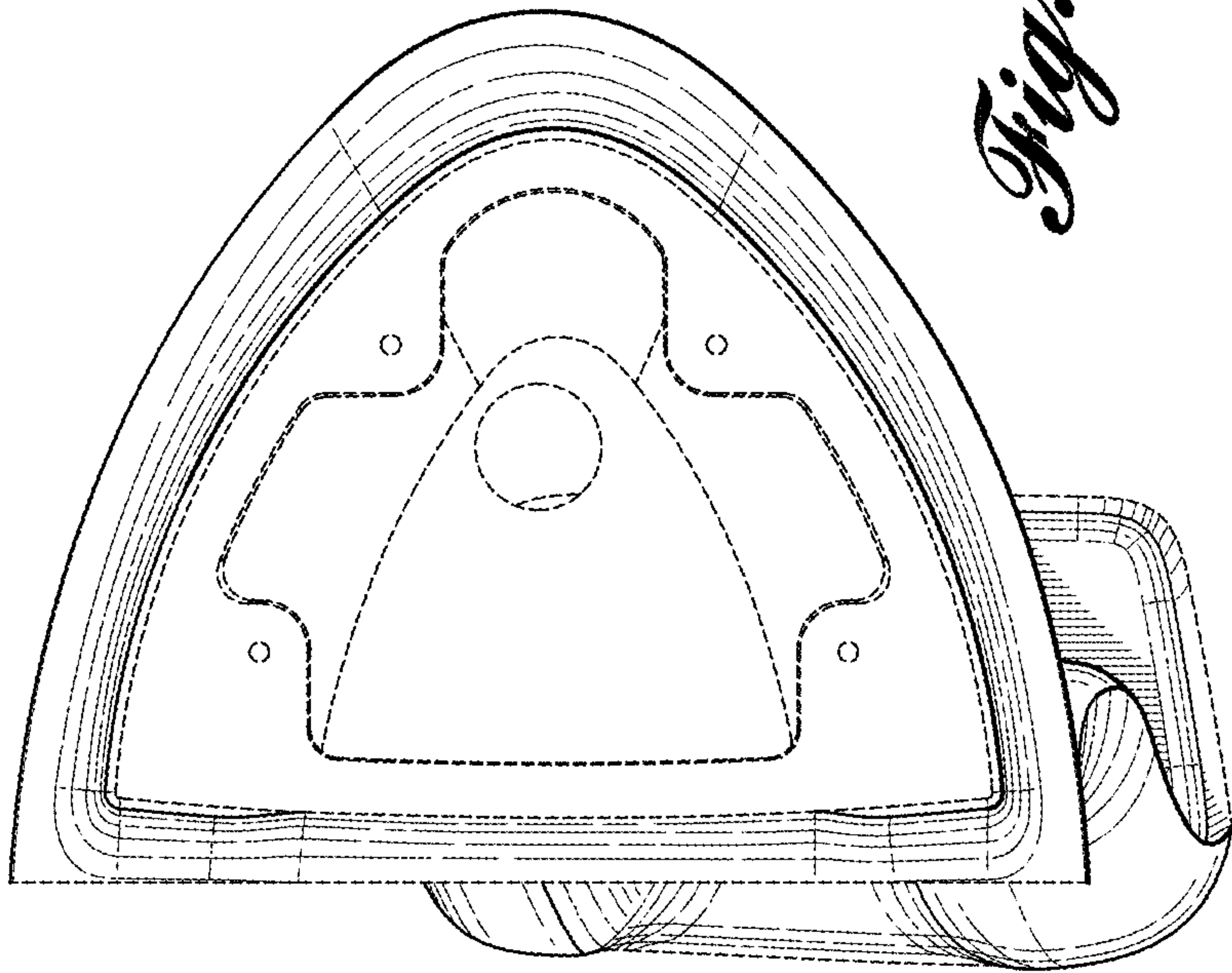
*Fig. 5.*



*Fig. 6.*



*Fig. 8.*



*Fig. 7.*

