



US00D789815S

(12) **United States Design Patent** (10) **Patent No.:** **US D789,815 S**
Khattak et al. (45) **Date of Patent:** **** Jun. 20, 2017**

(54) **READER OF AN ANALYTE DETECTION SYSTEM**

Primary Examiner — Antoine D Davis
(74) *Attorney, Agent, or Firm* — Foley & Lardner LLP; Antoinette F. Konski; Christopher C. Bolten

(71) Applicant: **CUE INC.**, San Diego, CA (US)

(72) Inventors: **Ayub Khattak**, San Diego, CA (US); **Clinton Sever**, San Diego, CA (US)

(57) **CLAIM**

(73) Assignee: **CUE INC.**, San Diego, CA (US)

We claim the ornamental design for a reader of an analyte detection system, as shown and described.

(**) Term: **15 Years**

(21) Appl. No.: **29/574,538**

(22) Filed: **Aug. 16, 2016**

DESCRIPTION

Related U.S. Application Data

(62) Division of application No. 29/545,014, filed on Nov. 9, 2015, now Pat. No. Des. 774,407, which is a (Continued)

FIG. 1A is a top, front, and left side perspective view of a reader of an analyte detection system according to an exemplary embodiment, showing one possible exemplary embodiment of a charger in dashed lines; FIG. 1B is an exploded view thereof; FIG. 1C is a left side view thereof; FIG. 1D is a right side view thereof; FIG. 1E is a top view thereof; FIG. 1F is a bottom view thereof; FIG. 1G is a front view thereof; FIG. 1H is a rear view thereof; FIG. 2A is a top, front, and left side perspective view of the exemplary embodiment of FIG. 1A, showing one possible exemplary embodiment of a charger, a cartridge, and a sample collection device in dashed lines; FIG. 2B is an exploded view thereof; FIG. 2C is a left side view thereof; FIG. 2D is a right side view thereof; FIG. 2E is a top view thereof; FIG. 2F is a bottom view thereof; FIG. 2G is a front view thereof; and, FIG. 2H is a rear view thereof. The ornamental design which is claimed is shown in solid lines in the drawings. The broken lines formed by dashes show unclaimed subject matter and form no part of the claimed design. Broken lines formed by unequal length dashes (i.e., dash-dot) define boundaries of the claimed design.

(51) **LOC (10) Cl.** **10-04**

(52) **U.S. Cl.**
USPC **D10/81; D24/129**

(58) **Field of Classification Search**
USPC **D10/81; D24/129**
(Continued)

(56) **References Cited**

U.S. PATENT DOCUMENTS

3,915,806 A 10/1975 Horlach
D298,166 S 10/1988 Chennault
(Continued)

FOREIGN PATENT DOCUMENTS

CN 104232622 A 12/2014
EP 2 050 498 A1 4/2009
(Continued)

OTHER PUBLICATIONS

Advisory Action in U.S. Appl. No. 14/954,817, mailed Sep. 19, 2016.

(Continued)

1 Claim, 10 Drawing Sheets

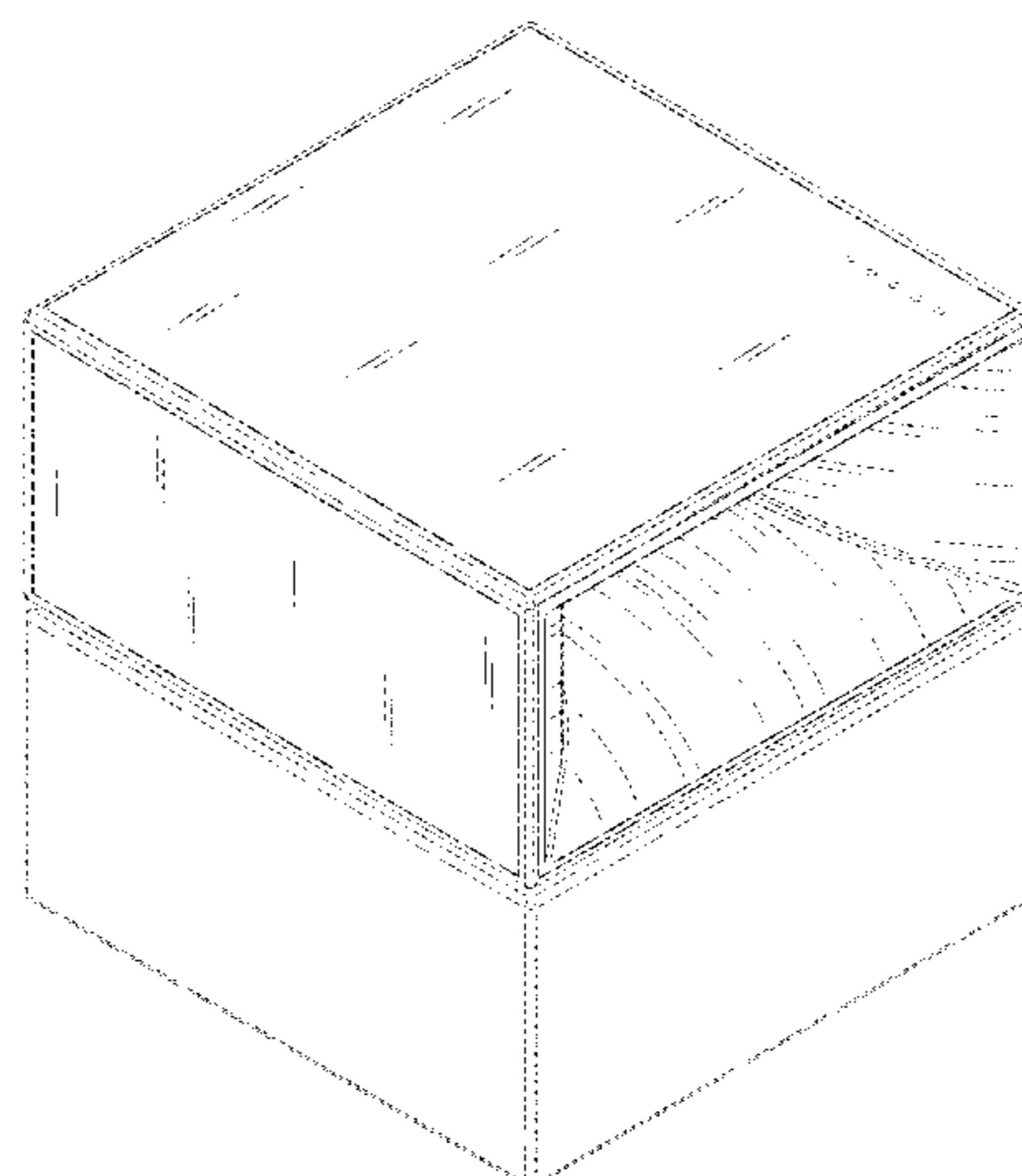

(56)

References Cited

FOREIGN PATENT DOCUMENTS

WO WO-2009/018473 A1 2/2009
 WO WO-2010/036808 A1 4/2010
 WO WO-2010/041231 4/2010
 WO WO-2010/140128 12/2010
 WO WO-2012/147426 11/2012
 WO WO-2012/170703 A1 12/2012
 WO WO-2013/136115 A1 9/2013
 WO WO-2013/144643 A2 10/2013

OTHER PUBLICATIONS

JP Office Action dated Aug. 4, 2016 in JP Patent Application Serial No. 2016-501354.

Notice of Allowance in U.S. Appl. No. 14/954,817, mailed Nov. 3, 2016.

Notice of Allowance in U.S. Appl. No. 29/545,014, mailed Sep. 2, 2016.

U.S. Appl. No. 29/545,014, filed Nov. 9, 2015, Cue Inc.

Anderson, J.C. et al. (2008) "Thermally-Actuated Microfluidic Systems," JALA 13:65-72.

Beyor, N. et al. (2008) "Immunomagnetic bead-based cell concentration microdevice for dilute pathogen detection," Biomed Microdevices 10:909-917.

Cecchet, F. et al. (2006) "Redox Mediation at 11-Mercaptoundecanoic Acid Self-Assembled Monolayers on Gold," J. Phys. Chem. B 110:2241-2248.

Chen, Z. et al. (2005) "Thermally-actuated, phase change flow control for microfluidic systems," Lab Chip 5:1277-1285.

Cho, H. et al. (2007) "How the capillary burst microvalve works," Journal of Colloid and Interface Science 306:379-385.

Clinical IVD Products: Liat™ Analyzer; IQuum, Inc.: <http://www.iquum.com/products/analyzer.shtml>. Last accessed May 5, 2014.

Corrected Notice of Allowability in U.S. Appl. No. 14/599,369, mailed May 11, 2016.

Extended European Search Report in European Patent Application No. 14779852.4, mailed Jul. 20, 2016.

Fan, R. et al. (2008) "Integrated barcode chips for rapid, multiplexed analysis of proteins in microliter quantities of blood," Nature Biotechnology 26(12):1373-1378.

Ferguson, B.S. et al. (2009) "Integrated Microfluidic Electrochemical DNA Sensor," Anal. Chem. 81:6503-6508.

Final Office Action in U.S. Appl. No. 14/205,146, mailed Apr. 3, 2015.

Final Office Action in U.S. Appl. No. 14/599,369, mailed Jan. 4, 2016.

Final Office Action in U.S. Appl. No. 14/954,817, mailed May 23, 2016.

Henares, T.G. et al. (2007) "Integration of Multianalyte Sensing Functions on a Capillary-Assembled Microchip: Simultaneous Determination of Ion Concentrations and Enzymatic Activities by a "Drop-and-Sip" Technique," Anal. Chem. 79:908-915.

International Search Report and Written Opinion (ISA/EP) in International Application No. PCT/US2015/049439, mailed Dec. 7, 2015.

International Search Report and Written Opinion (ISA/KR) in International Application No. PCT/US2014/023821, mailed Jul. 7, 2014.

Jagannathan, H. et al. (2001) "Micro-Fluidic Channels with Integrated Ultrasonic Transducers," IEEE Ultrasonics Symposium:859-862.

Kaigala, G.V. et al. (2008) "Electrically controlled microvalves to integrate microchip polymerase chain reaction and capillary electrophoresis," Lab Chip 8:1071-1078.

Kim, D. et al. (2007) "A Bi-Polymer Micro One-Way Valve," Sensors and Actuators a 136:426-433.

Kinoshita, T. et al. (2007) "Functionalization of Magnetic Gold/Iron-Oxide Composite Nanoparticles with Oligonucleotides and Magnetic Separation of Specific Target," J. of Magnetism and Magnetic Materials 311:255-258.

Kwakye, S. et al. (2006) "Electrochemical Microfluidic Biosensor for Nucleic Acid Detection with Integrated Minipotentiostat," Biosensors and Bioelectronics 21: 2217-2223.

Laschi, S. et al. (2010) "A New Gravity-Driven Microfluidic-Based Electrochemical Assay Coupled to Magnetic Beads for Nucleic Acid Detection," Electrophoresis 31: 3727-3736.

Lawi, W. et al. (2009) "A Microfluidic Cartridge System for Multiplexed Clinical Analysis," J. Assoc. Laboratory Automation 14(6):407-412.

Lee, C.S. et al. (2001) "Microelectromagnets for the Control of Magnetic Nanoparticles," Applied Physics Letters 79(20):3308-3310.

Lillehoj, P.B. et al. (2010) "A Self-Pumping Lab-on-a-Chip for Rapid Detection of Botulinum Toxin," Lab Chip 10: 2265-2270.

Liu, R.H. et al. (2004) "Self-Contained, Fully Integrated Biochip for Sample Preparation, Polymerase Chain Reaction Amplification, and DNA Microarray Detection," Analytical Chemistry 76(7):1824-1831.

Liu, R.H. et al. (2004) "Single-use, Thermally Actuated Paraffin Valves for Microfluidic Applications," Sensors and Actuators B 98:328-336.

Lomas, N. (2014) "Cue Is a Connected Lab-In-A-Box for On-Demand Health Testing At Home," TechCrunch.

Marentis, T.C. et al. (2005) "Microfluidic Sonicator for Real-Time Disruption of Eukaryotic Cells and Bacterial Spores for DNA Analysis," Ultrasound in Med. & Biol. 31(9):1265-1277.

Mrksich, M. et al. (1997) "Using Self-Assembled Monolayers that Present Oligo(ethylene glycol) Groups to Control the Interactions of Proteins with Surfaces," American Chemical Society Symposium Series 680:361-373.

Non-Final Office Action in U.S. Appl. No. 14/205,146, mailed Apr. 6, 2016.

Non-Final Office Action in U.S. Appl. No. 14/205,146, mailed Sep. 26, 2014.

Non-Final Office Action in U.S. Appl. No. 14/479,149, mailed Jan. 13, 2015.

Non-Final Office Action in U.S. Appl. No. 14/543,842, mailed Feb. 12, 2015.

Non-Final Office Action in U.S. Appl. No. 14/599,369, mailed Aug. 18, 2015.

Non-Final Office Action in U.S. Appl. No. 14/599,372, mailed Mar. 27, 2015.

Non-Final Office Action in U.S. Appl. No. 14/599,375, mailed Jun. 19, 2015.

Non-Final Office Action in U.S. Appl. No. 14/954,817, mailed Feb. 2, 2016.

Notice of Allowance in U.S. Appl. No. 14/205,146, mailed Oct. 22, 2015.

Notice of Allowance in U.S. Appl. No. 14/479,149, mailed Mar. 6, 2015.

Notice of Allowance in U.S. Appl. No. 14/543,842, mailed Apr. 24, 2015.

Notice of Allowance in U.S. Appl. No. 14/599,365, mailed May 1, 2015.

Notice of Allowance in U.S. Appl. No. 14/599,369, mailed Apr. 22, 2016.

Notice of Allowance in U.S. Appl. No. 14/599,372, mailed Sep. 14, 2015.

Notice of Allowance in U.S. Appl. No. 14/599,375, mailed Aug. 26, 2015.

Notice of Allowance in Design U.S. Appl. No. 29/490,660, mailed Aug. 20, 2015.

Office Action in Design U.S. Appl. No. 29/490,660, mailed Jun. 25, 2014.

Prindle, D. (2014) "Sick? Need more vitamin D? Testosterone? Lick a stick and Cue fills you in," www.digitaltrends.com.

Restriction Requirement in U.S. Appl. No. 14/599,369, mailed May 7, 2015.

Restriction Requirement in Design U.S. Appl. No. 29/490,660, mailed Jun. 2, 2015.

Restriction Requirement in Design U.S. Appl. No. 29/545,014, mailed May 10, 2016.

(56)

References Cited

OTHER PUBLICATIONS

Rida, A. et al. (2004) "Manipulation of Self-Assembled Structures of Magnetic Beads for Microfluidic Mixing and Assaying," *Analytical Chemistry* 76(21):6239-6246.

Roderee, K. et al. (2011) "DNA Hybridization Enhancement Using Piezoelectric Microagitation through a Liquid Coupling Medium," *Lab Chip*, doi:10.1039/C0LC00419G.

Sharma, V. et al. (2007) "Surface Characterization of Plasma-Treated and PEG-Grafted PDMS for Micro Fluidic Applications," *Vacuum* 81:1094-1100.

Shin, Y.S. et al. (2010) "Chemistries for Patterning Robust DNA MicroBarcodes Enable Multiplex Assays of Cytoplasm Proteins from Single Cancer Cells," *ChemPhysChem* 11:3063-3069.

Simplexa™ Flu A/B & RSV Direct Kit; Focus Diagnostics, Inc.: <https://www.focusdx.com/product/MOL2650>. Last accessed May 5, 2014.

Supplementary Partial European Search Report in European Application No. 14779852.4, mailed Feb. 11, 2016.

Taylor, M.T. et al. (2001) "Lysing Bacterial Spores by Sonication through a Flexible Interface in a Microfluidic System," *Analytical Chemistry* 73(3):492-496.

The FilmArray System; Biofire Diagnostics, Inc.: <http://filmarray.com/the-panels/>. Last accessed May 5, 2014.

Wang, J. (2002) "Portable Electrochemical Systems," *Trends in Analytical Chemistry* 21(4):226-232.

Wang, J. et al. (2005) "Self-Actuated, Thermo-Responsive Hydrogel Valves for Lab on a Chip," *Biomedical Microdevices* 7(4):313-322.

Wang, J. et al. (2010) "A Self-Powered, One-Step Chip for Rapid, Quantitative and Multiplexed Detection of Proteins from Pinpricks of Whole Blood," *Lab Chip* 10:3157-3162.

Wu, C. et al. (2011) "Ultrasonication on a Microfluidic Chip to Lyse Single and Multiple Pseudo-Nitzschia for Marine Biotoxin Analysis," *Biotechnology Journal* 6:150-155.

Xpert® Flu; Cepheid: <http://www.cepheid.com/us/cepheid-solutions/clinical-ivd-tests/critical-infectious-diseases/xpert-flu>. Last accessed May 5, 2014.

Yoshioka, K. et al. (2010) "Suppression of Non-specific Adsorption Using Densified Tri(ethylene glycol) Alkanethiols: Monolayer Characteristics Evaluated by Electrochemical Measurements," *Analytical Sciences* 26:33-37.

Ziegler, J. et al. (2008) "High-Performance Immunoassays Based on Through-Stencil Patterned Antibodies and Capillary Systems," *Analytical Chemistry* 80(5):1763-1769.

International Search Report and Written Opinion, PCT/US2016/042688, Cue Inc, 15 pages (Jan. 10, 2017).

Notice of Allowance in U.S. Appl. No. 15/336,735, mailed Jan. 5, 2017.

US Non-Final Office Action dated Dec. 21, 2016 in U.S. Appl. No. 14/205,146.

US Non-Final Office Action dated Feb. 9, 2017 in U.S. Appl. No. 15/336,715.

US Non-Final Office Action dated Jan. 27, 2017 in U.S. Appl. No. 15/336,502.

US Non-Final Office Action dated Jan. 30, 2017 in U.S. Appl. No. 15/336,487.

US Notice of Allowance in U.S. Appl. No. 15/172,077, mailed Feb. 10, 2017.

* cited by examiner

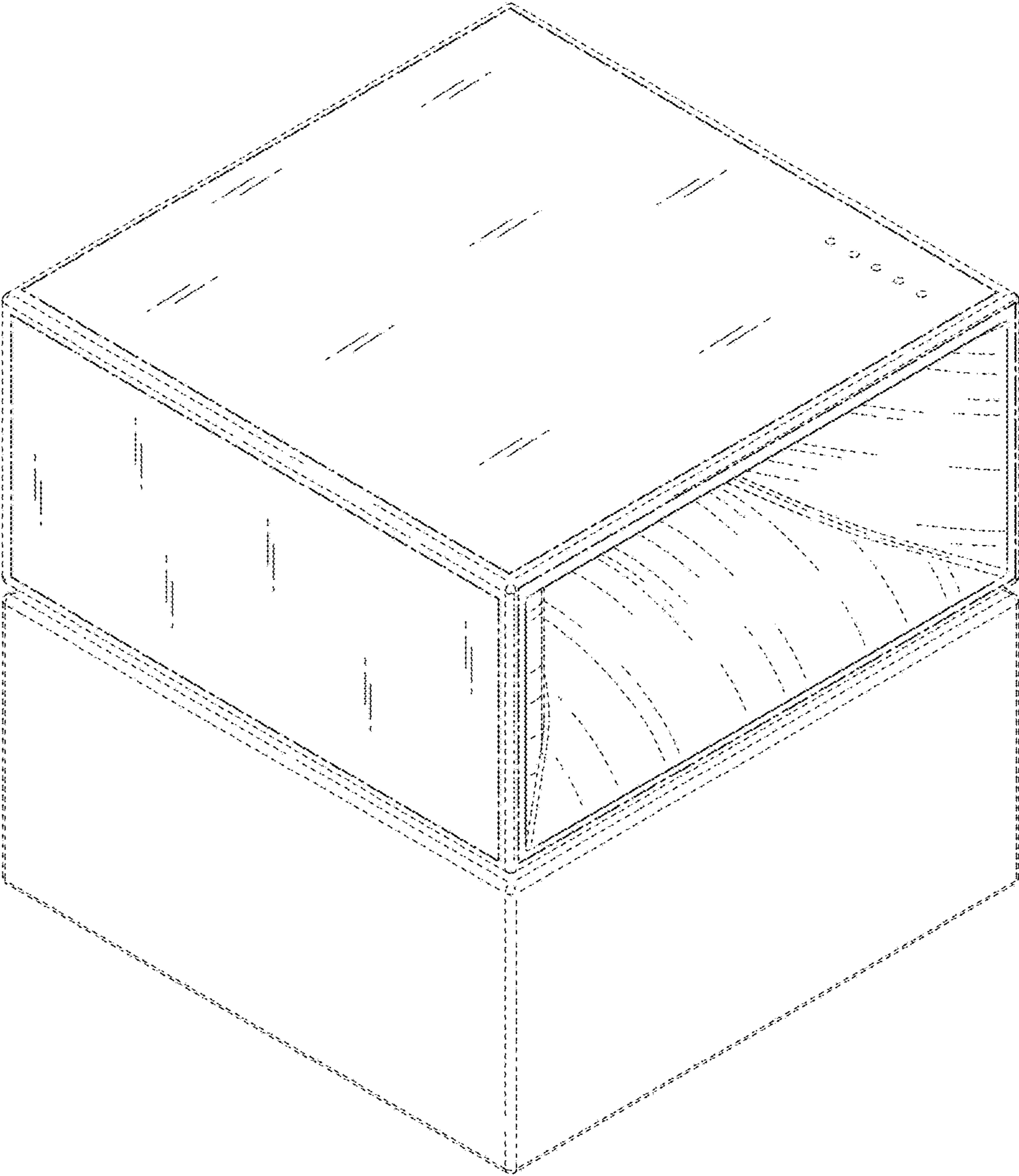

FIG. 1A

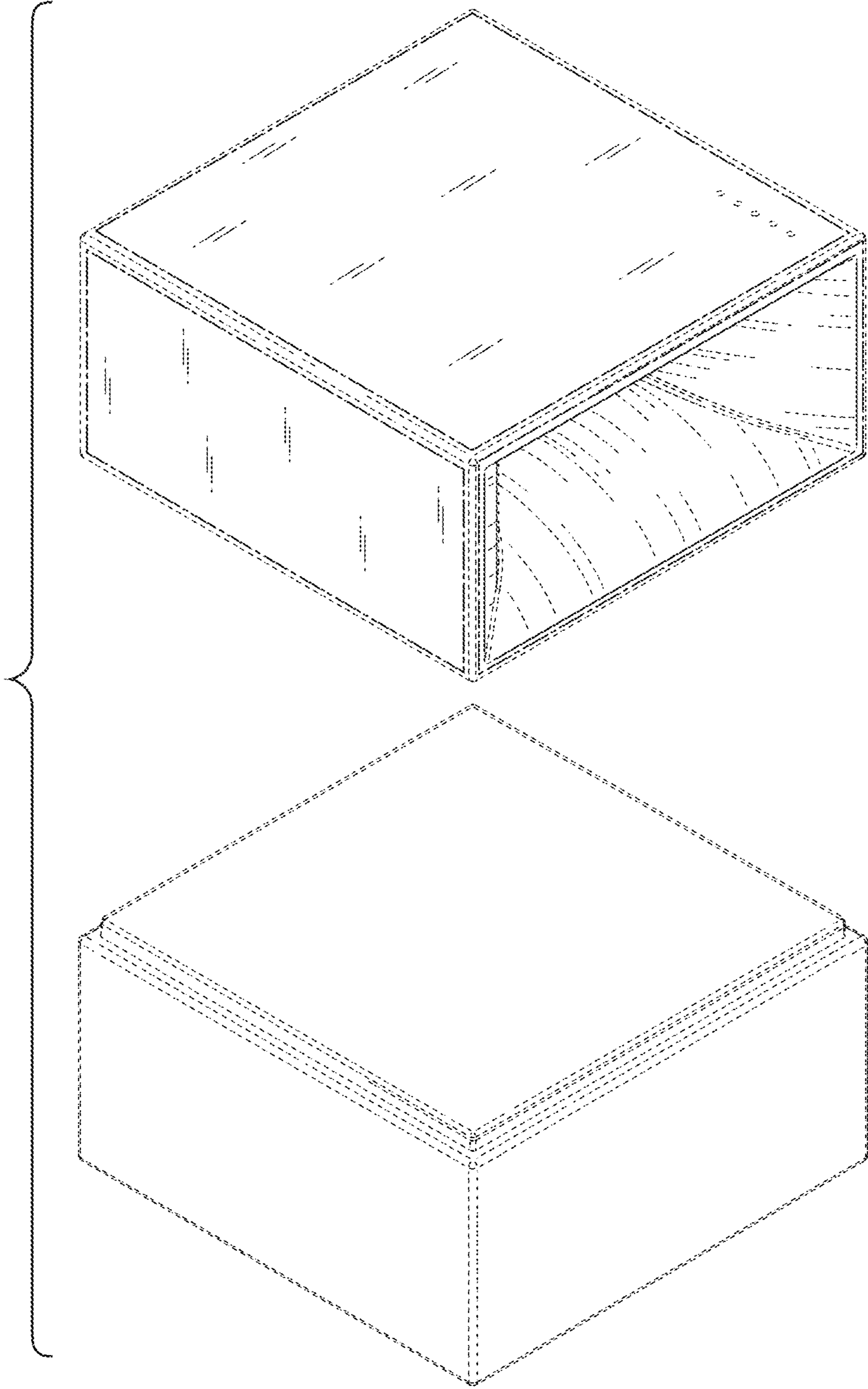

FIG. 1B

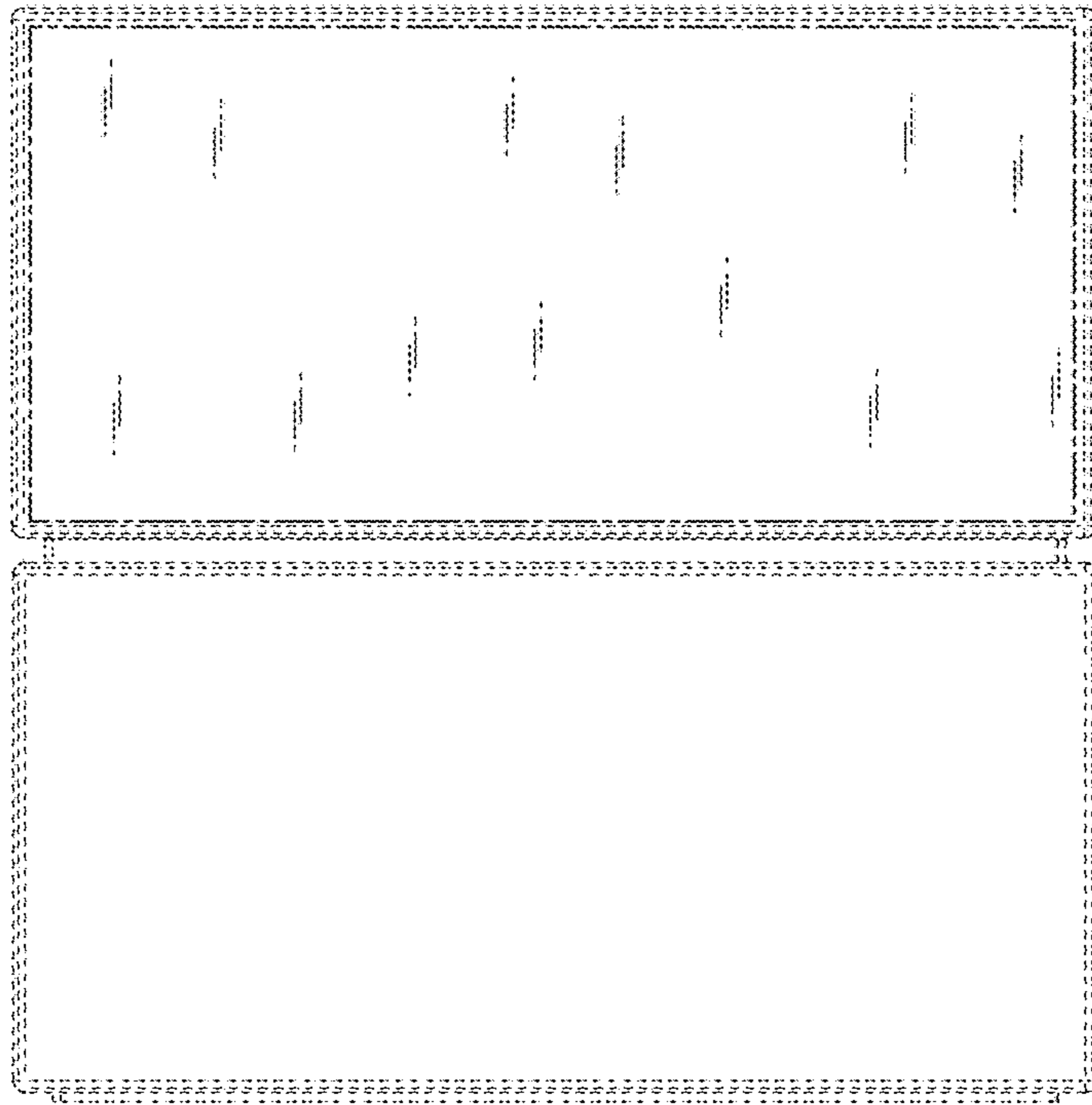

FIG. 1C

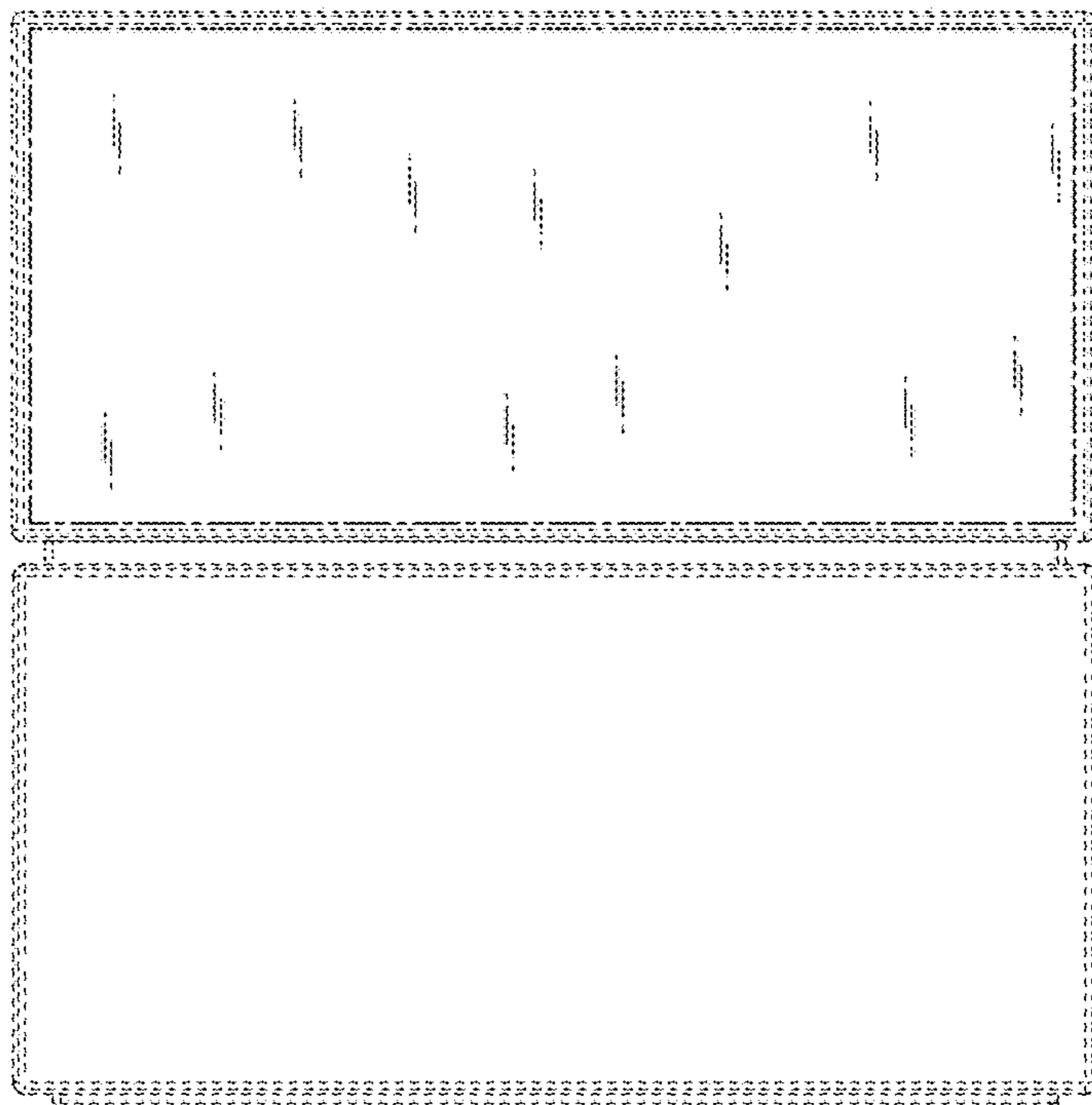

FIG. 1D



FIG. 1E

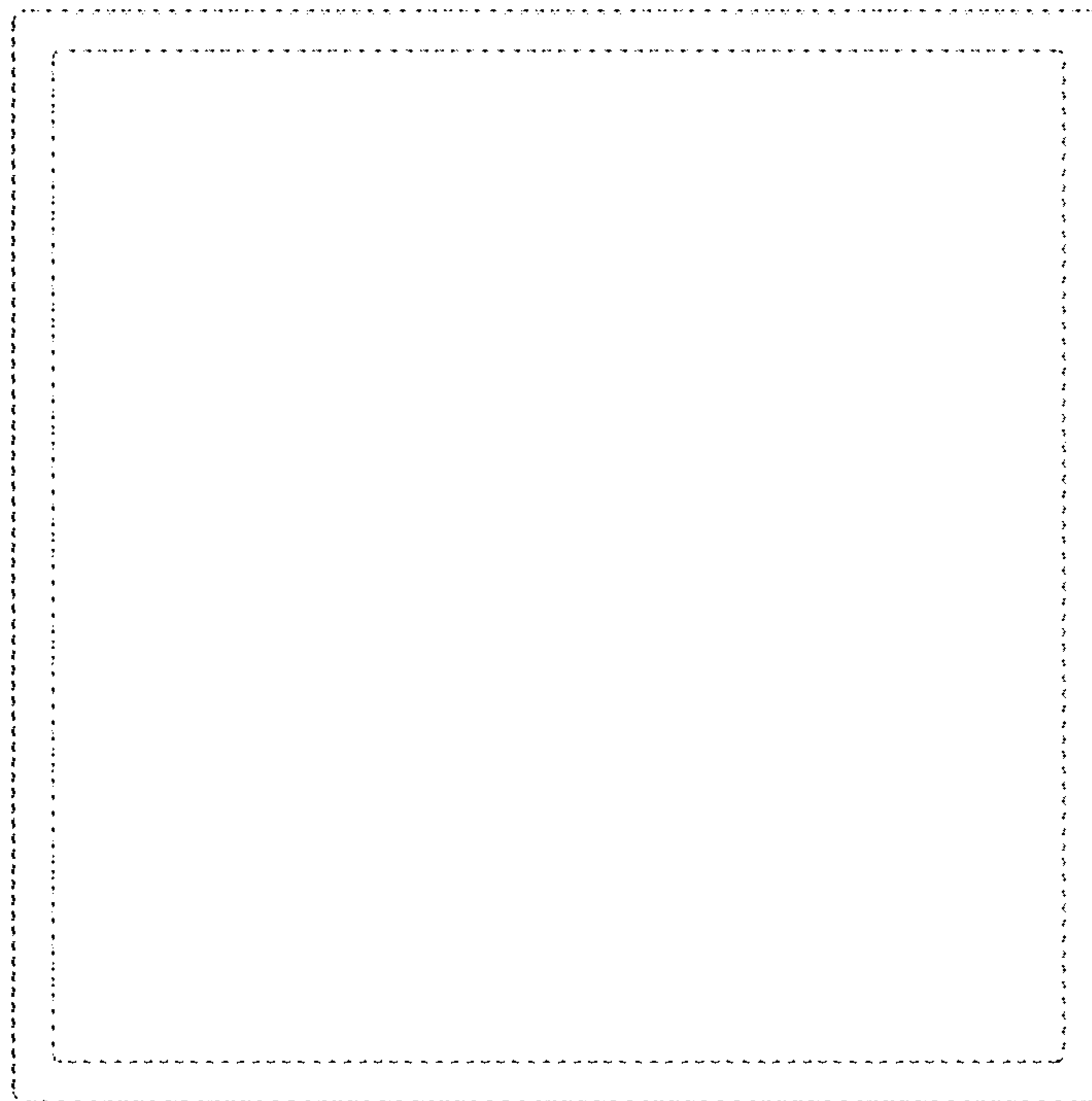

FIG. 1F

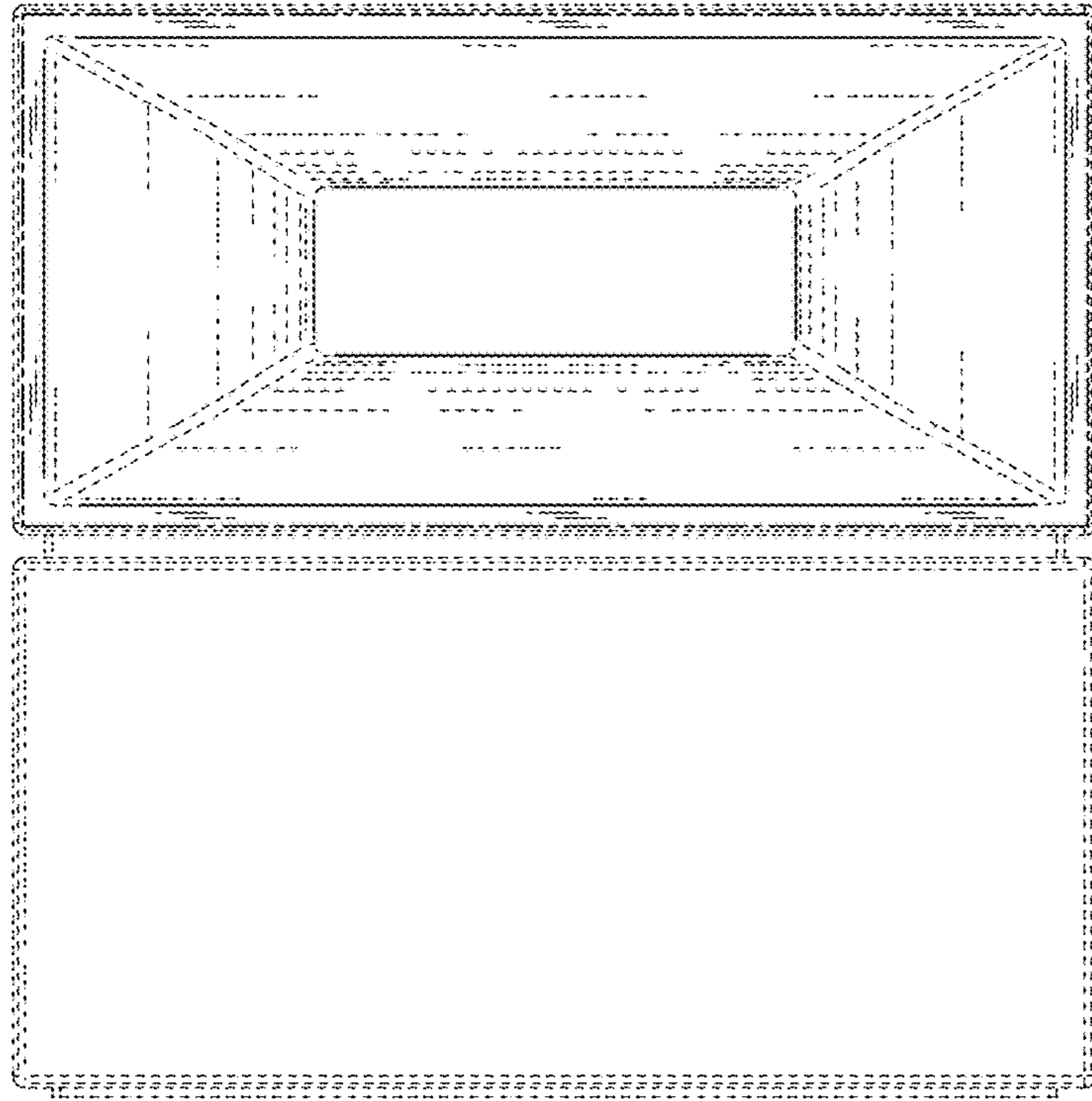

FIG. 1G

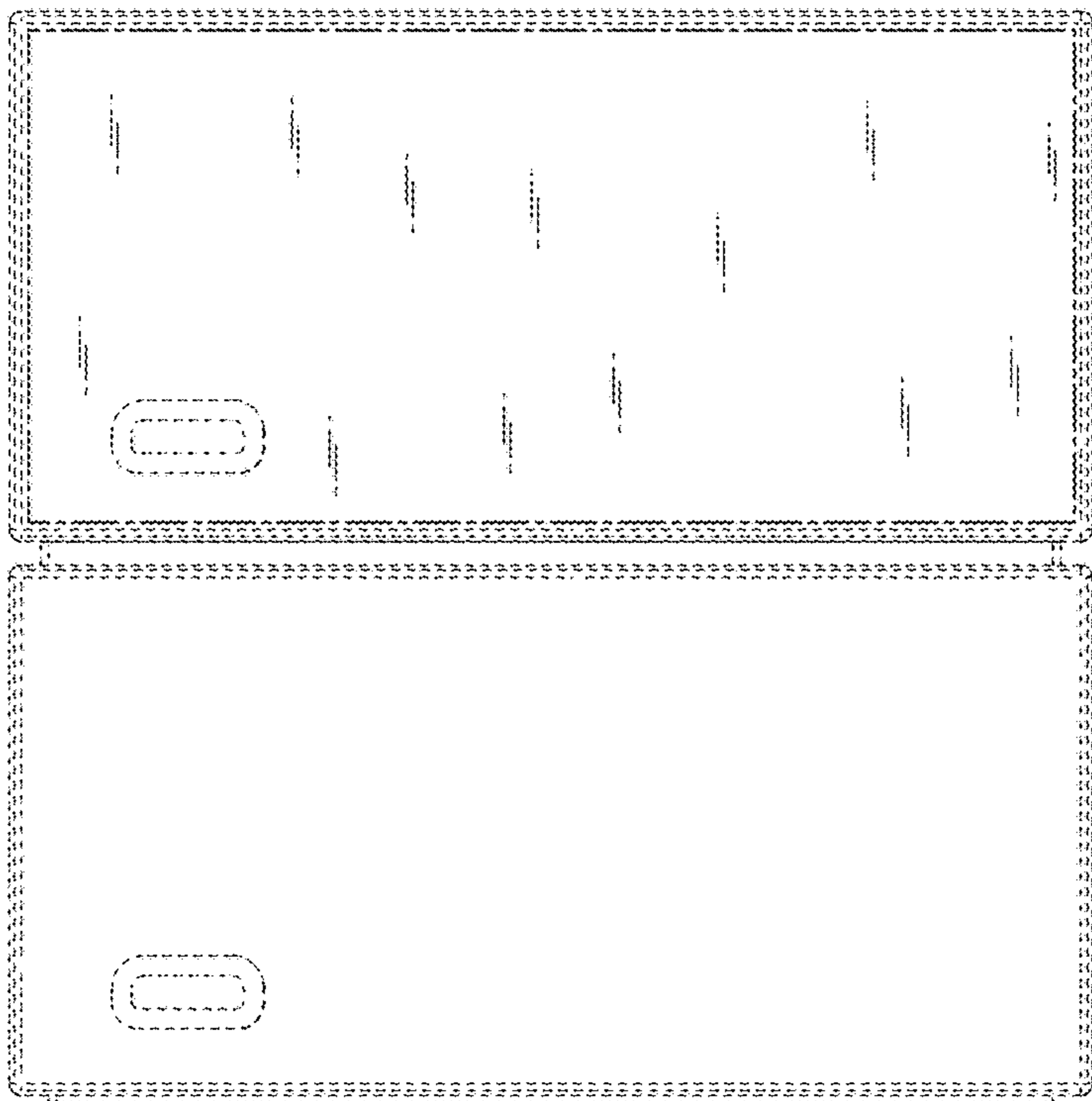

FIG. 1H

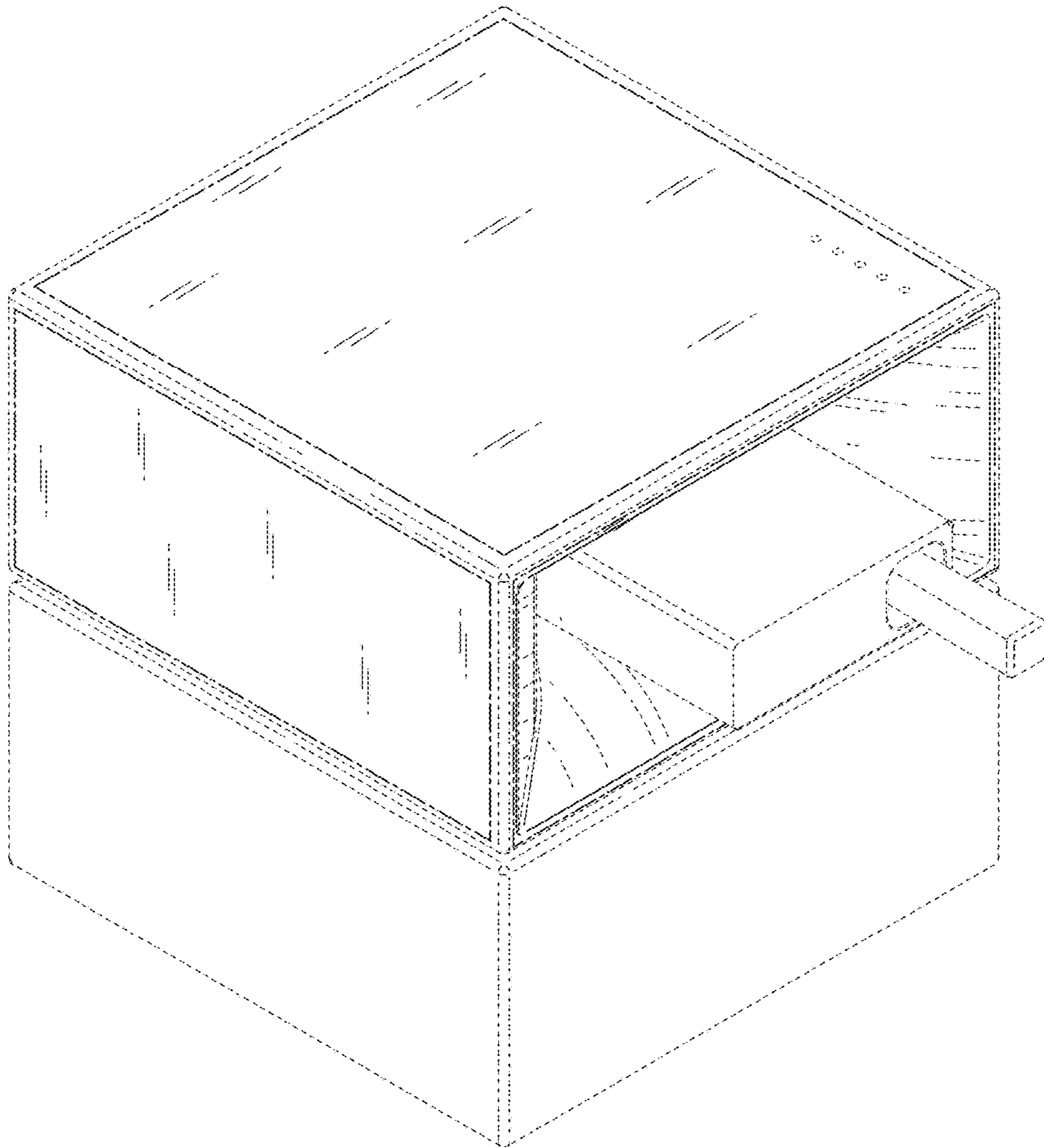

FIG. 2A

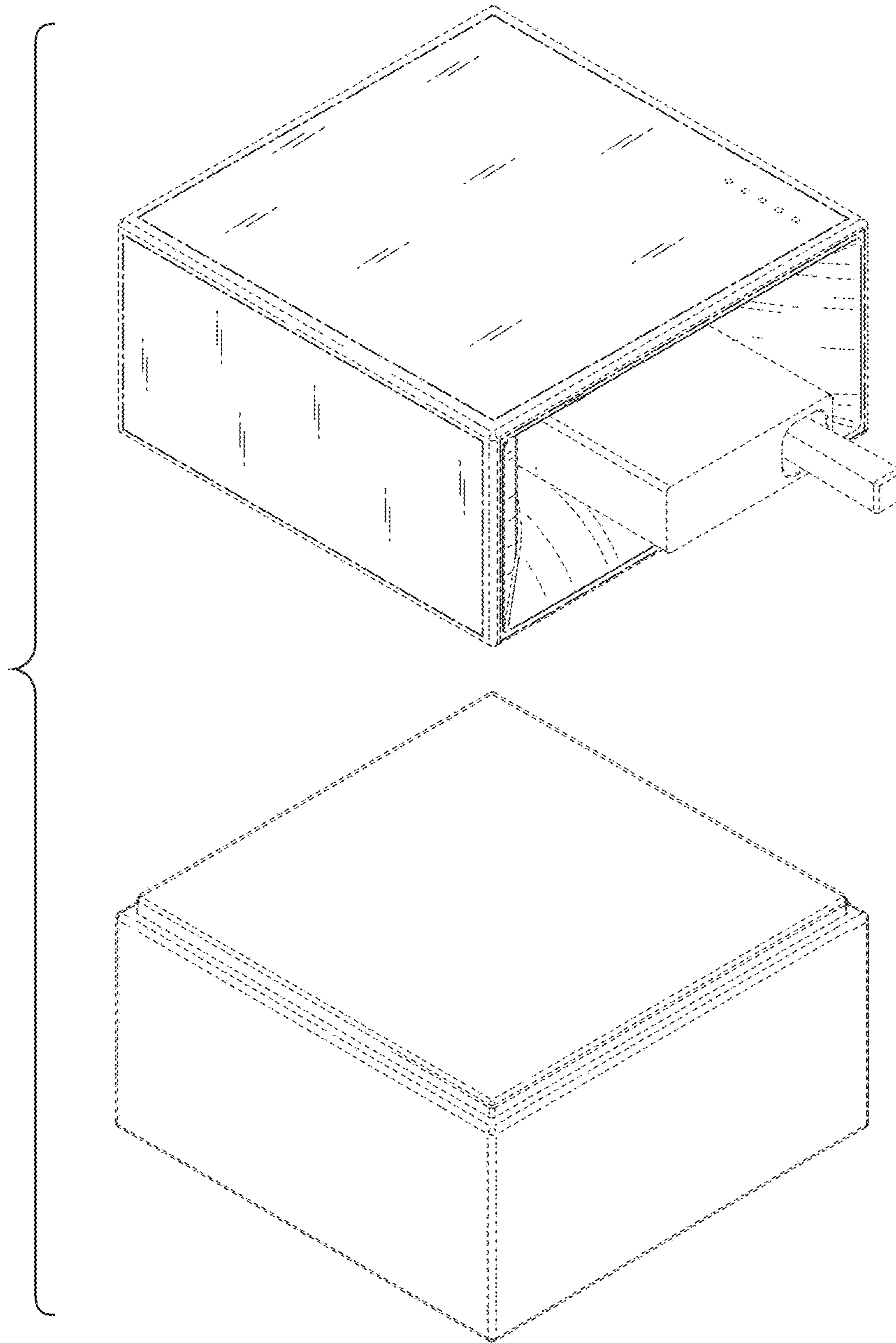

FIG. 2B

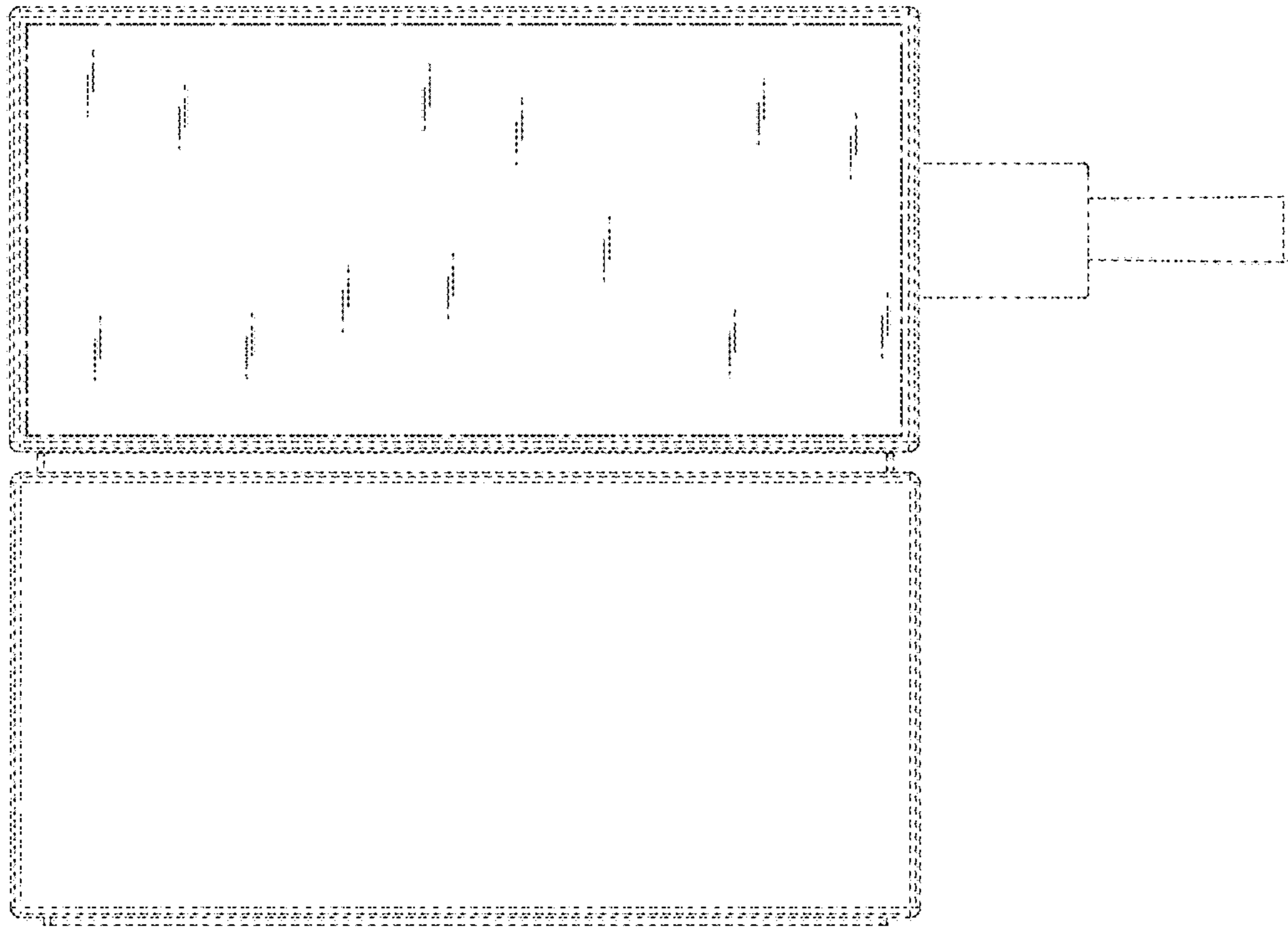

FIG. 2C

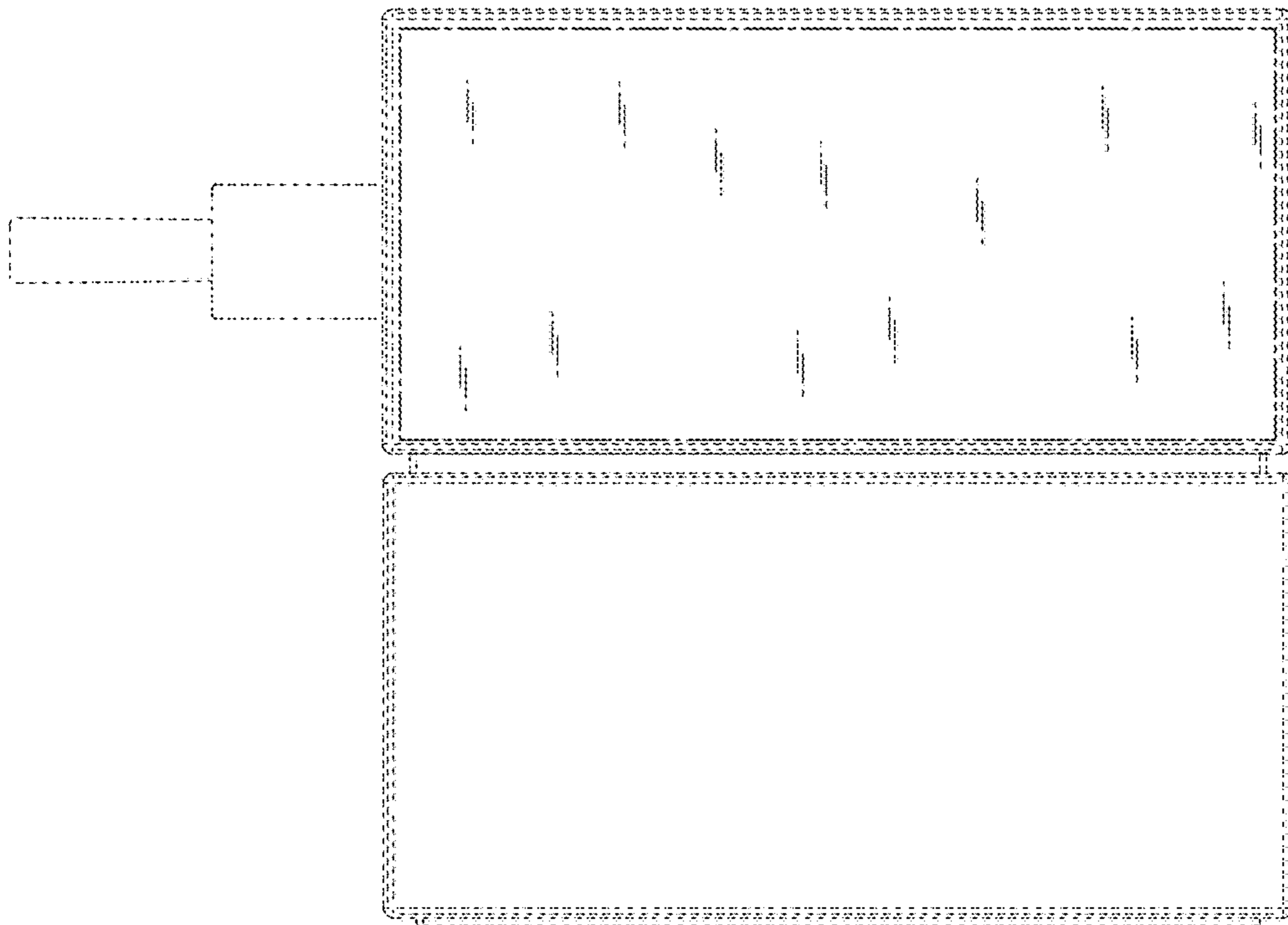

FIG. 2D

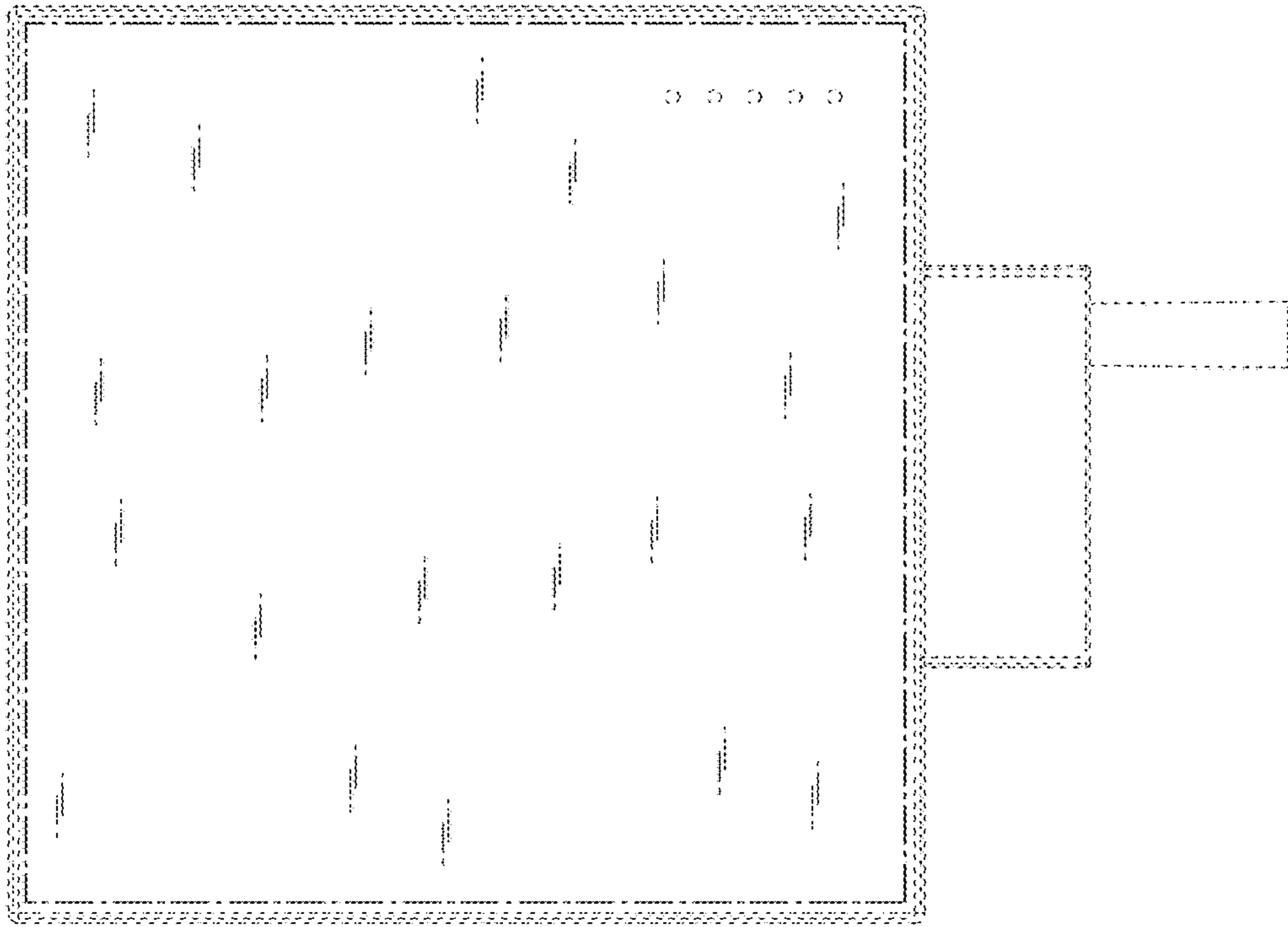

FIG. 2E

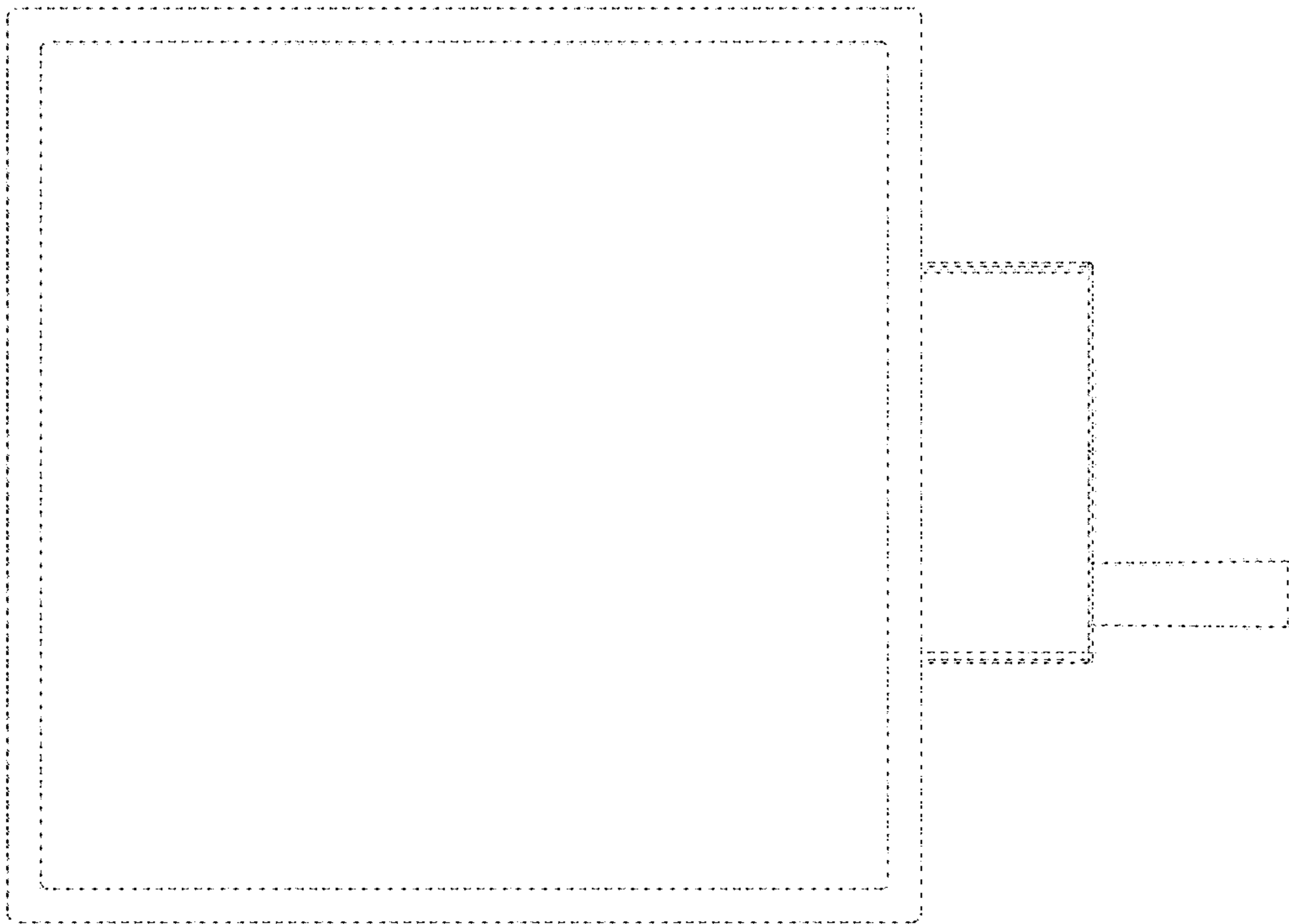

FIG. 2F

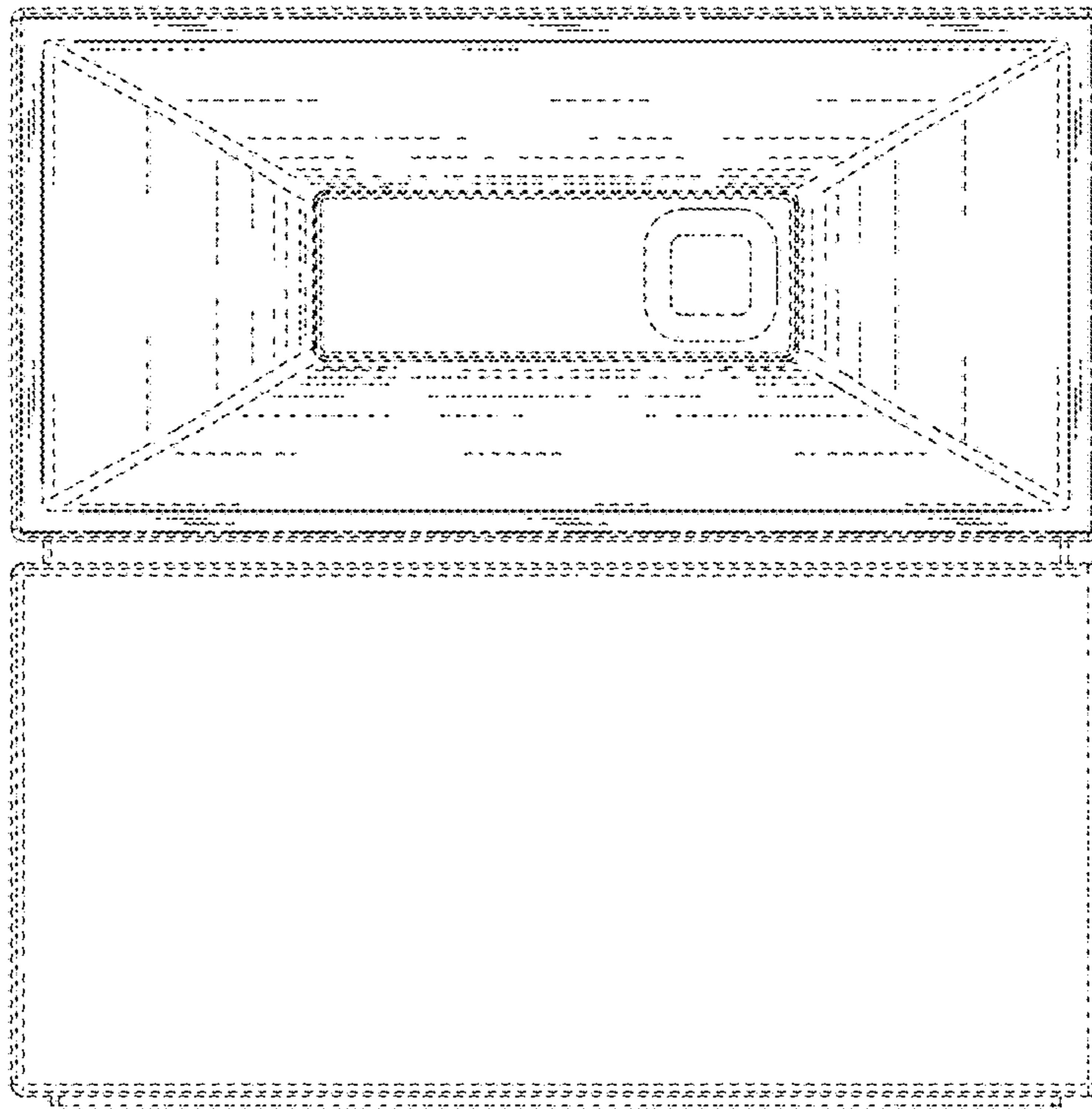

FIG. 2G

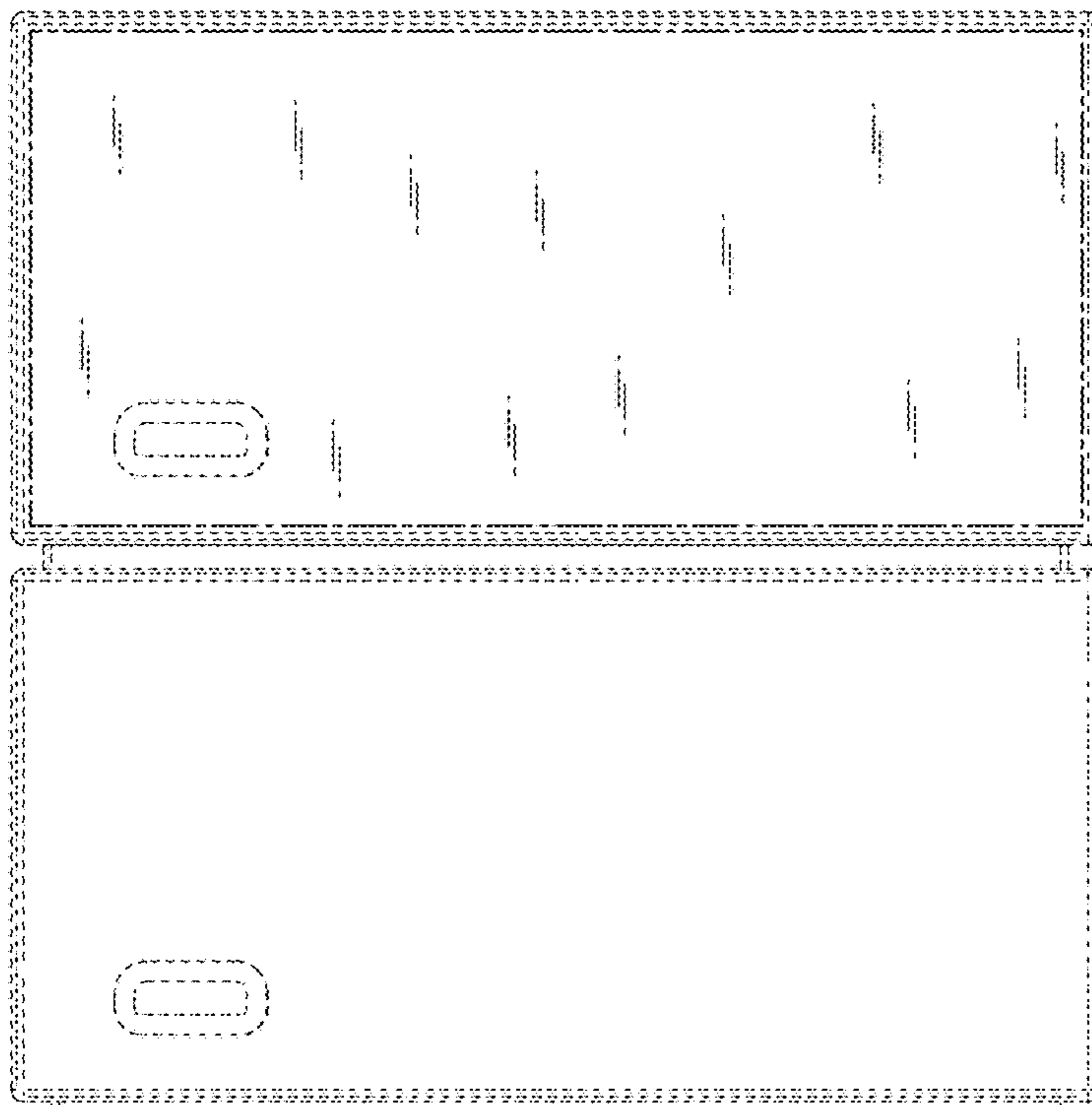

FIG. 2H