



US00D789722S

(12) **United States Design Patent**  
**Volpe**

(10) **Patent No.:** **US D789,722 S**  
(45) **Date of Patent:** **\*\* Jun. 20, 2017**

(54) **CHAIR**

(71) Applicant: **Kohler Interiors Furniture Company,**  
Hickory, NC (US)

(72) Inventor: **Steven Volpe,** San Francisco, CA (US)

(73) Assignee: **KOHLER INTERIORS FURNITURE**  
**COMPANY,** Hickory, NC (US)

(\*\*) Term: **15 Years**

(21) Appl. No.: **29/565,601**

(22) Filed: **May 23, 2016**

**Related U.S. Application Data**

(62) Division of application No. 29/506,680, filed on Oct.  
17, 2014, now Pat. No. Des. 762,406.

(51) **LOC (10) Cl.** ..... **06-01**

(52) **U.S. Cl.**

USPC ..... **D6/716; D6/360; D6/369**

(58) **Field of Classification Search**

USPC ..... D6/334-336, 360, 369, 371-373, 374,  
D6/375, 376, 379, 716, 716.1, 716.2,  
D6/716.3, 716.4

CPC .. A47C 5/02; A47C 5/06; A47C 7/282; A47C  
7/285; A47C 7/54; A47C 9/007; A47C  
23/18

See application file for complete search history.

(56) **References Cited**

**U.S. PATENT DOCUMENTS**

D171,610 S 3/1954 Morrison  
2,830,350 A \* 4/1958 Wootton ..... A47C 5/06  
297/452.64

D141,647 S 6/1975 Bannister  
D256,409 S 8/1980 Wilson  
D418,687 S 1/2000 Tihany  
D454,260 S \* 3/2002 Tseng ..... D6/360  
D465,668 S 11/2002 Gaylord  
D465,669 S 11/2002 Gaylord  
6,983,987 B2 1/2006 Gaylord  
D762,406 S \* 8/2016 Volpe ..... D6/369

\* cited by examiner

*Primary Examiner* — Mimoso De

(74) *Attorney, Agent, or Firm* — Foley & Lardner LLP

(57) **CLAIM**

I claim the ornamental design for a chair, as shown and described.

**DESCRIPTION**

FIG. 1 is a top, front, left perspective view of an embodiment of the claimed design;

FIG. 2 is a front elevation view thereof;

FIG. 3 is a rear elevation view thereof;

FIG. 4 is a left elevation view thereof;

FIG. 5 is a right elevation view thereof;

FIG. 6 is a top plan view thereof; and,

FIG. 7 is a bottom plan view thereof.

The broken lines in the drawings form no part of the claimed design. Broken lines formed by equal length dashes show unclaimed subject matter. Broken lines formed of unequal length dashes (i.e., dash-dot) define bounds of the claimed design. Broken away symbols having a jagged element show that no particular length of the portion is claimed.

**1 Claim, 6 Drawing Sheets**

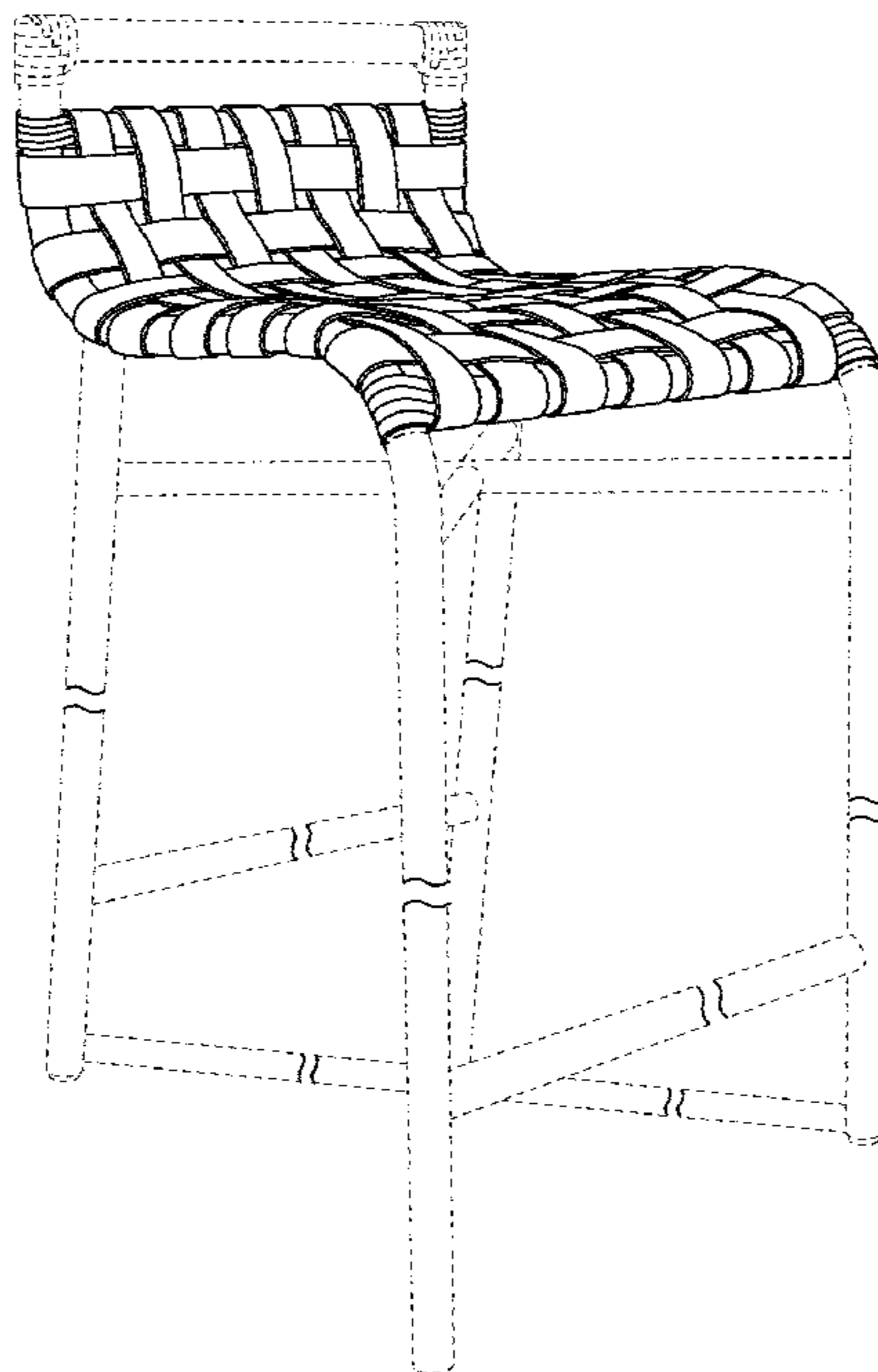

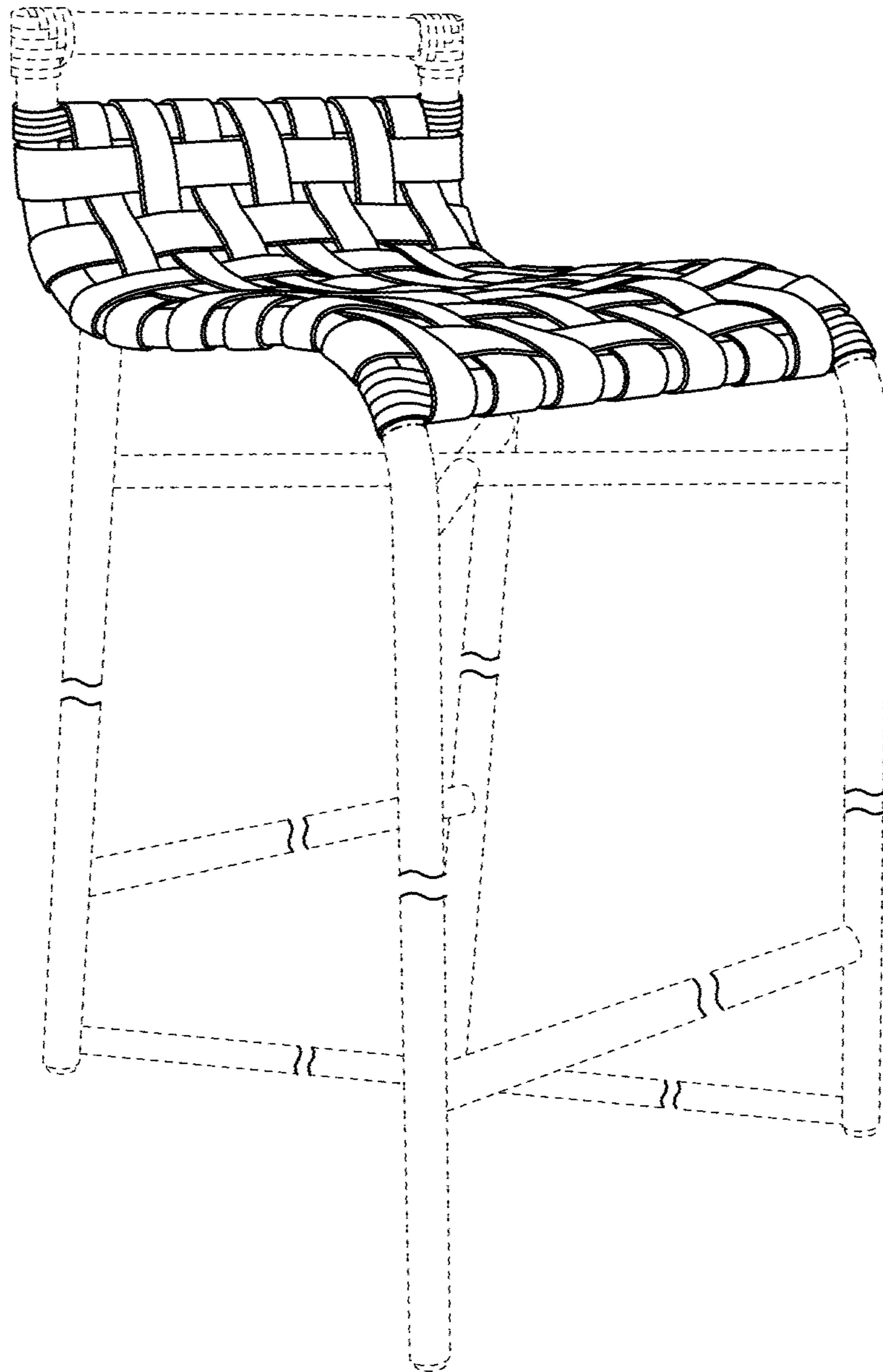

FIG. 1

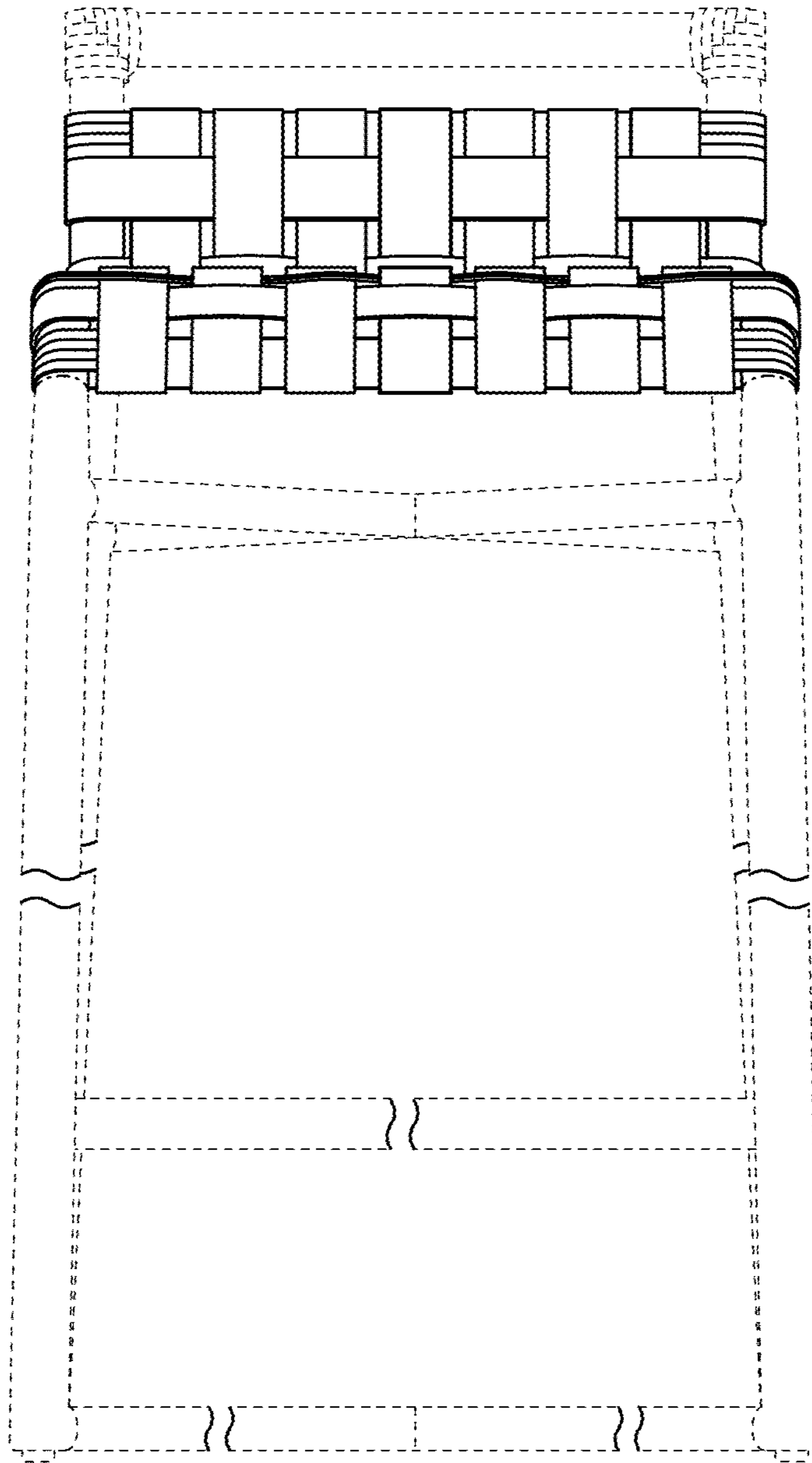

FIG. 2

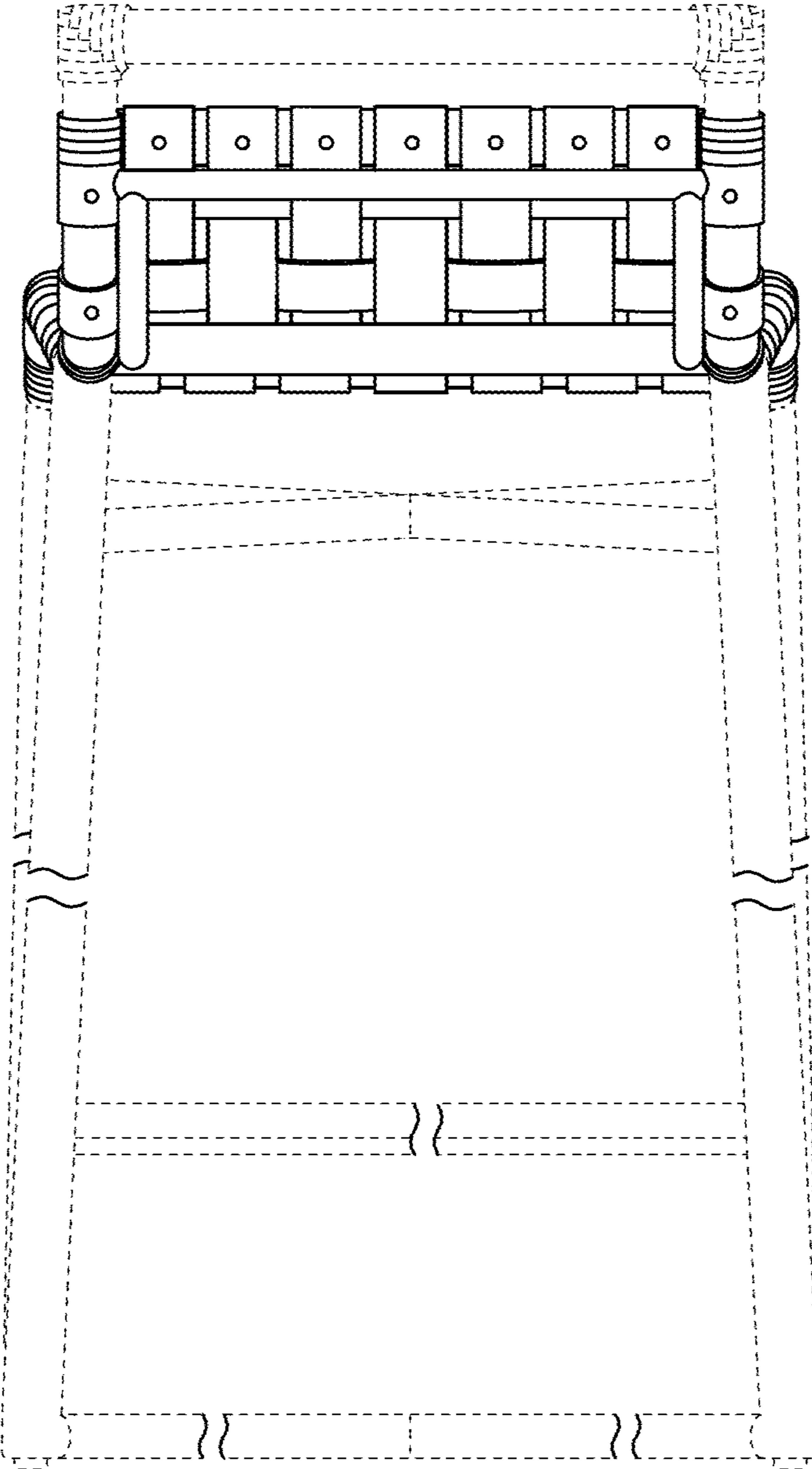

FIG. 3

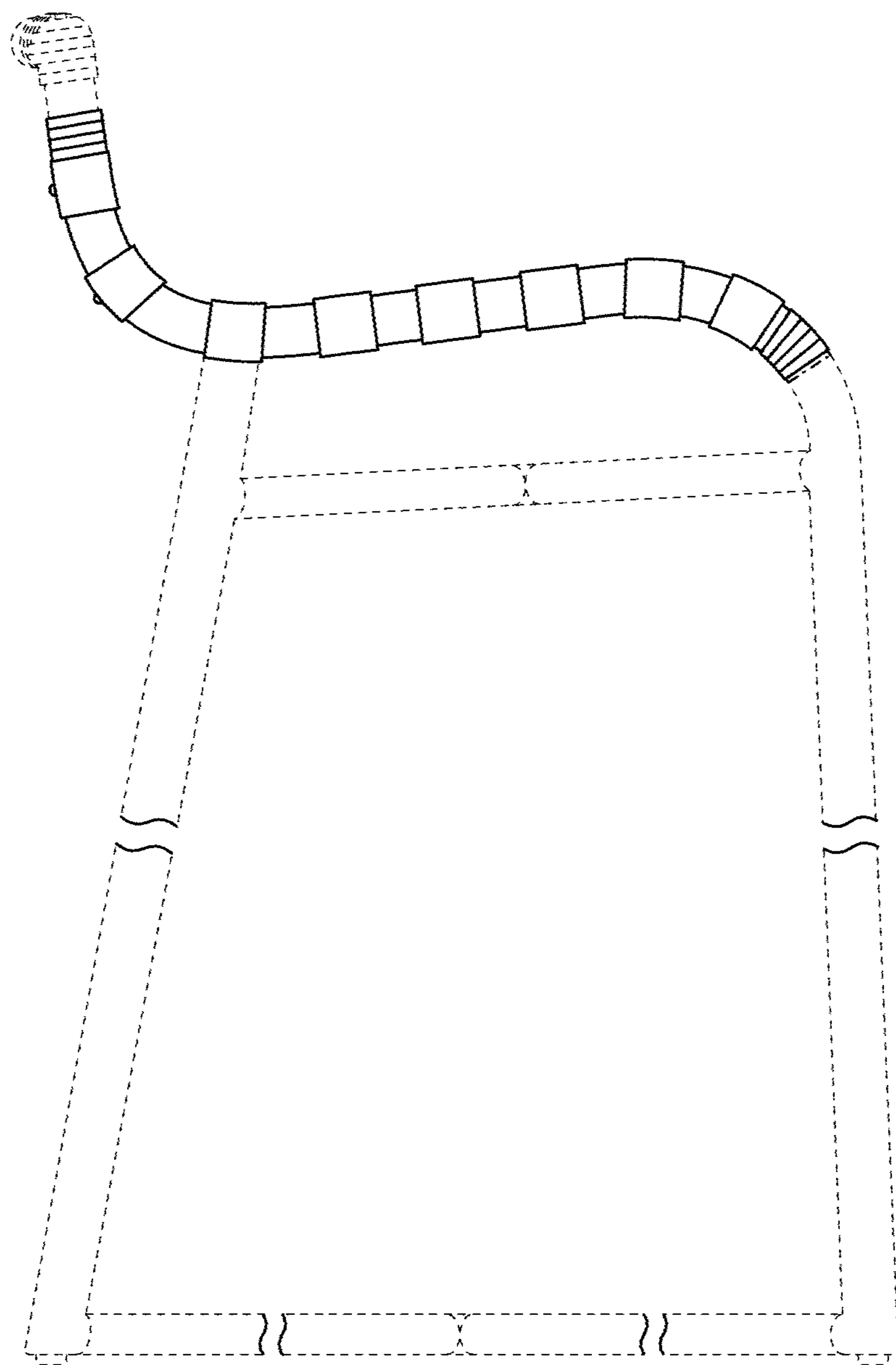

FIG. 4

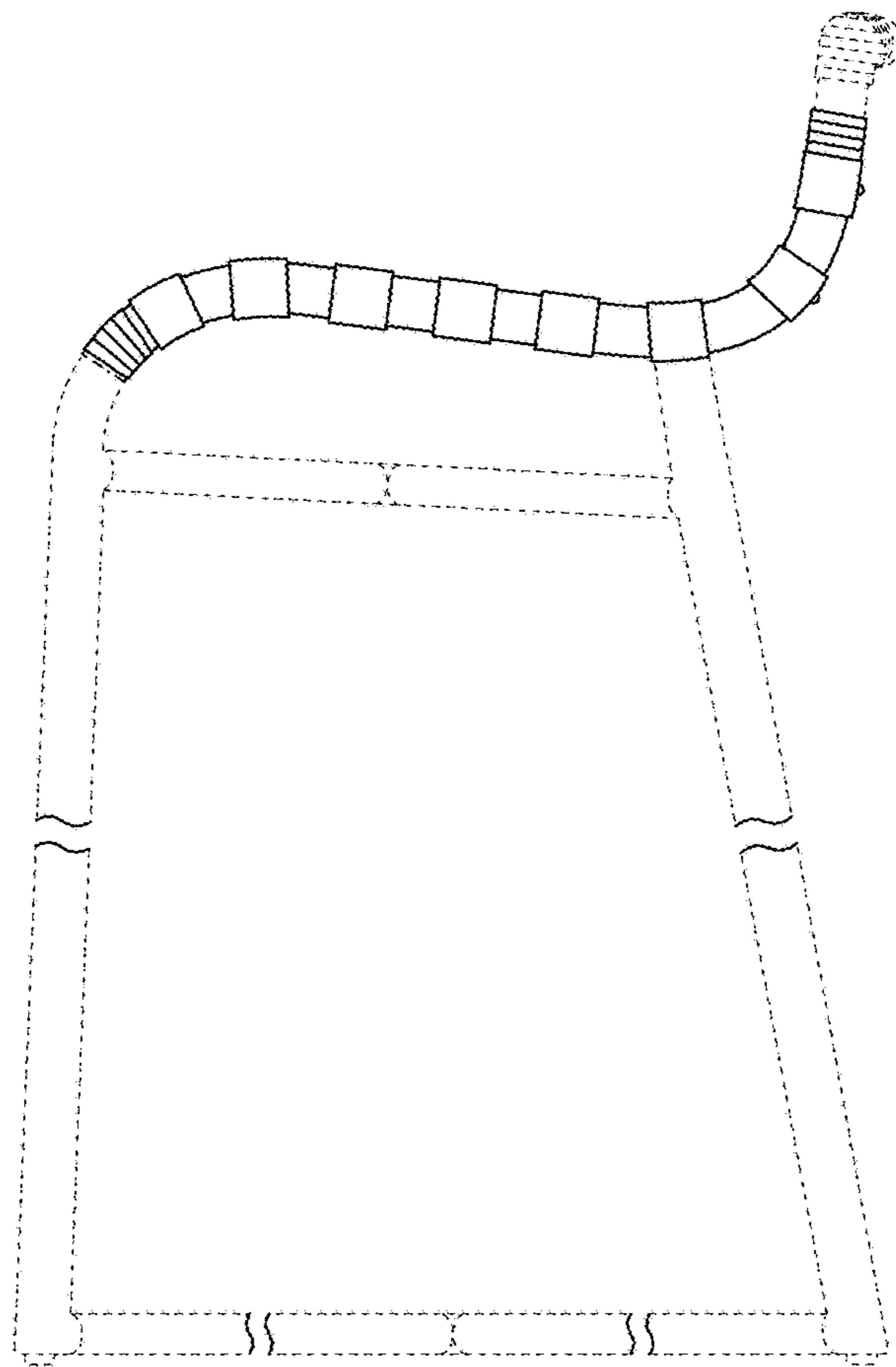

FIG. 5



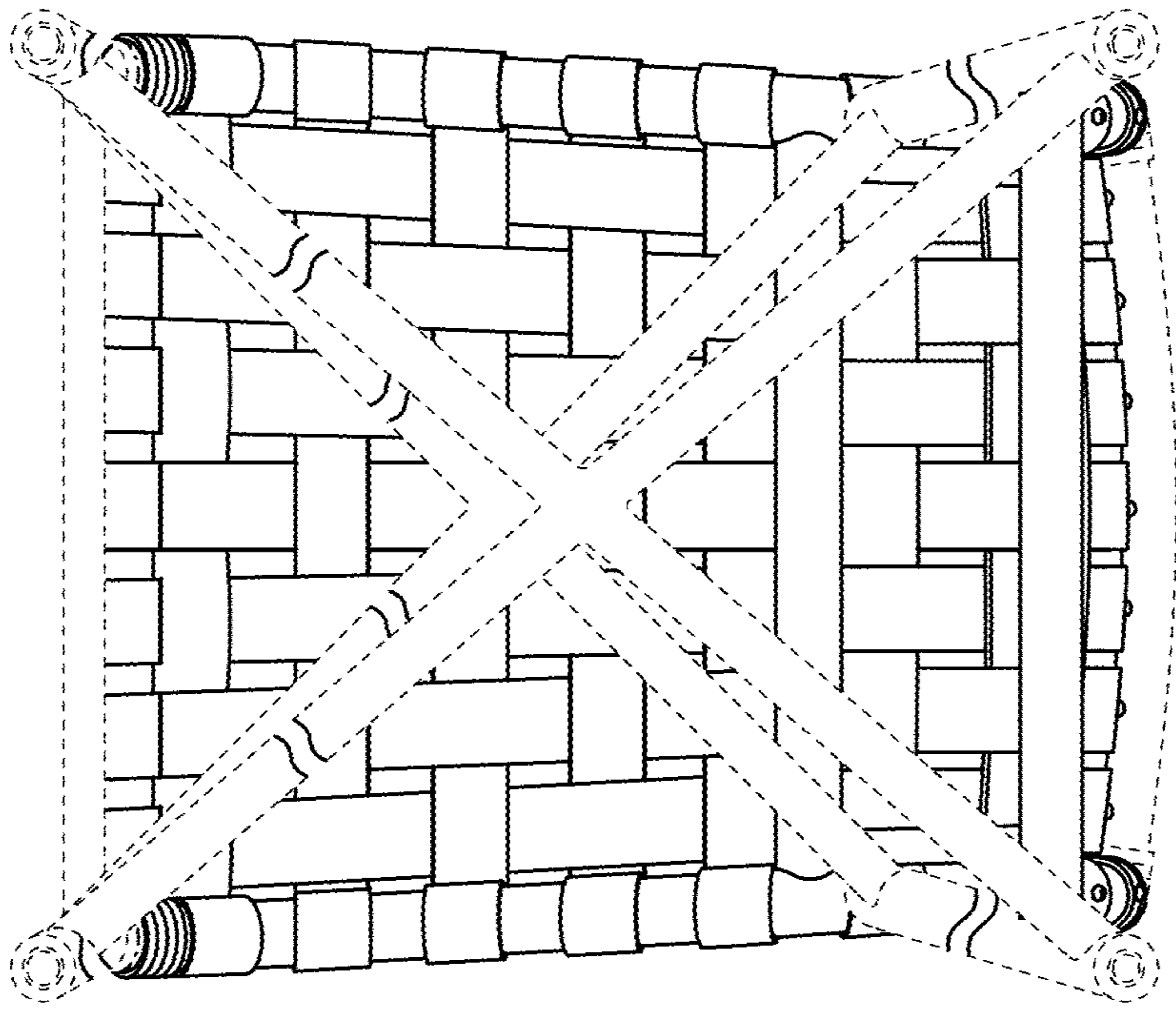

FIG. 7

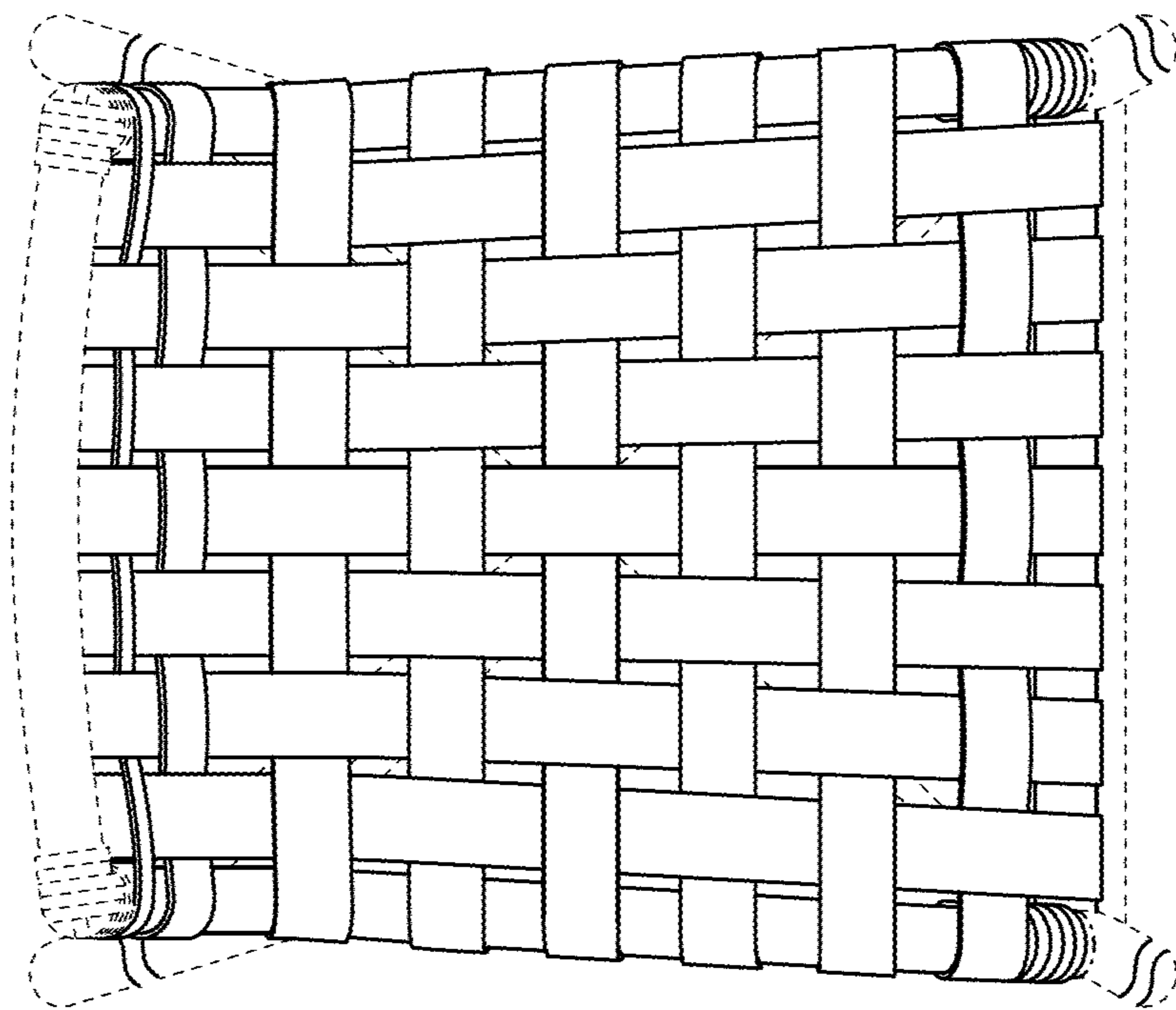

FIG. 6