



US00D789372S

(12) **United States Design Patent**  
**Trishaun**

(10) **Patent No.:** **US D789,372 S**

(45) **Date of Patent:** **\*\* Jun. 13, 2017**

(54) **SENSOR WAND**

(71) Applicant: **HipScience, LLC**, Orlando, FL (US)

(72) Inventor: **Marquette Trishaun**, Orlando, FL (US)

(73) Assignee: **HIPSCIENCE, LLC**, Orlando, FL (US)

(\*\*) Term: **15 Years**

(21) Appl. No.: **29/564,966**

(22) Filed: **May 17, 2016**

(51) **LOC (10) Cl.** ..... **14-02**

(52) **U.S. Cl.**  
USPC ..... **D14/433**

(58) **Field of Classification Search**  
USPC .... D14/356, 432-434, 453, 454, 511, 203.8,  
D14/209.1, 238.1, 240, 125; 439/638,  
439/928, 105, 502; 710/303, 304;  
361/679.41, 679.55, 679.56; D13/110,  
D13/133, 146  
CPC ..... H01R 24/64; H01R 24/62; H01R 12/714;  
H01R 13/506; H01R 13/6658  
See application file for complete search history.

(56) **References Cited**

**U.S. PATENT DOCUMENTS**

D559,848 S *	1/2008	Siu	.....	D14/433
D604,725 S *	11/2009	Chen	.....	D13/184
D627,784 S *	11/2010	Yamamoto	.....	D14/433
D643,841 S *	8/2011	Lyford	.....	D13/133
D670,291 S *	11/2012	Dalton	.....	B25C 7/00
				D14/433
D678,286 S *	3/2013	Cheng	.....	D14/433
D709,892 S *	7/2014	Lui	.....	D14/433
D731,489 S *	6/2015	Langhammer	.....	D14/433
D747,722 S *	1/2016	Webb	.....	D14/433
D755,185 S *	5/2016	Khanampornpan	.....	D14/433
D759,016 S *	6/2016	Zaslavsky	.....	D14/433

D778,913 S *	2/2017	Huang	.....	D13/110
D778,914 S *	2/2017	Huang	.....	D13/110
D781,294 S *	3/2017	Schwalbach	.....	D14/433

**OTHER PUBLICATIONS**

Go Wireless pH, Vernier Software & Technology, retrieved May 13, 2016, <http://www.vernier.com/products/sensors/ph-sensors/gw-ph/>, 7 pages.

Go Wireless Temp, Vernier Software & Technology, retrieved May 13, 2016, <http://www.vernier.com/products/sensors/temperature-sensors/gw-temp/>, 6 pages.

Wireless pH Sensor-PS-3204: Pasco, retrieved May 13, 2016, [https://www.pasco.com/prodcatalog/PS/PS-3204\\_wireless-ph-sensor/index.fcm](https://www.pasco.com/prodcatalog/PS/PS-3204_wireless-ph-sensor/index.fcm), 5 pages.

\* cited by examiner

*Primary Examiner* — Austin Murphy

(74) *Attorney, Agent, or Firm* — Brian S. Steinberger; Law Offices of Brian S. Steinberger, P.A.

(57) **CLAIM**

The ornamental design for a sensor wand, as shown and described.

**DESCRIPTION**

FIG. 1 is an upper front right perspective view of the novel sensor wand.

FIG. 2 is a lower front right perspective view of the sensor wand of FIG. 1.

FIG. 3 is an upper rear left perspective view of the novel sensor wand of FIG. 1.

FIG. 4 is a lower rear left perspective view of the novel sensor wand of FIG. 1.

FIG. 5 is a front side view of the sensor wand of FIG. 1.

FIG. 6 is a rear side view of the sensor wand of FIG. 1.

FIG. 7 is a right side view of the sensor wand of FIG. 1.

FIG. 8 is a left side view of the sensor wand of FIG. 1.

FIG. 9 is a top view of the sensor wand of FIG. 1; and,

FIG. 10 is a bottom view of the sensor wand of FIG. 1.

**1 Claim, 10 Drawing Sheets**

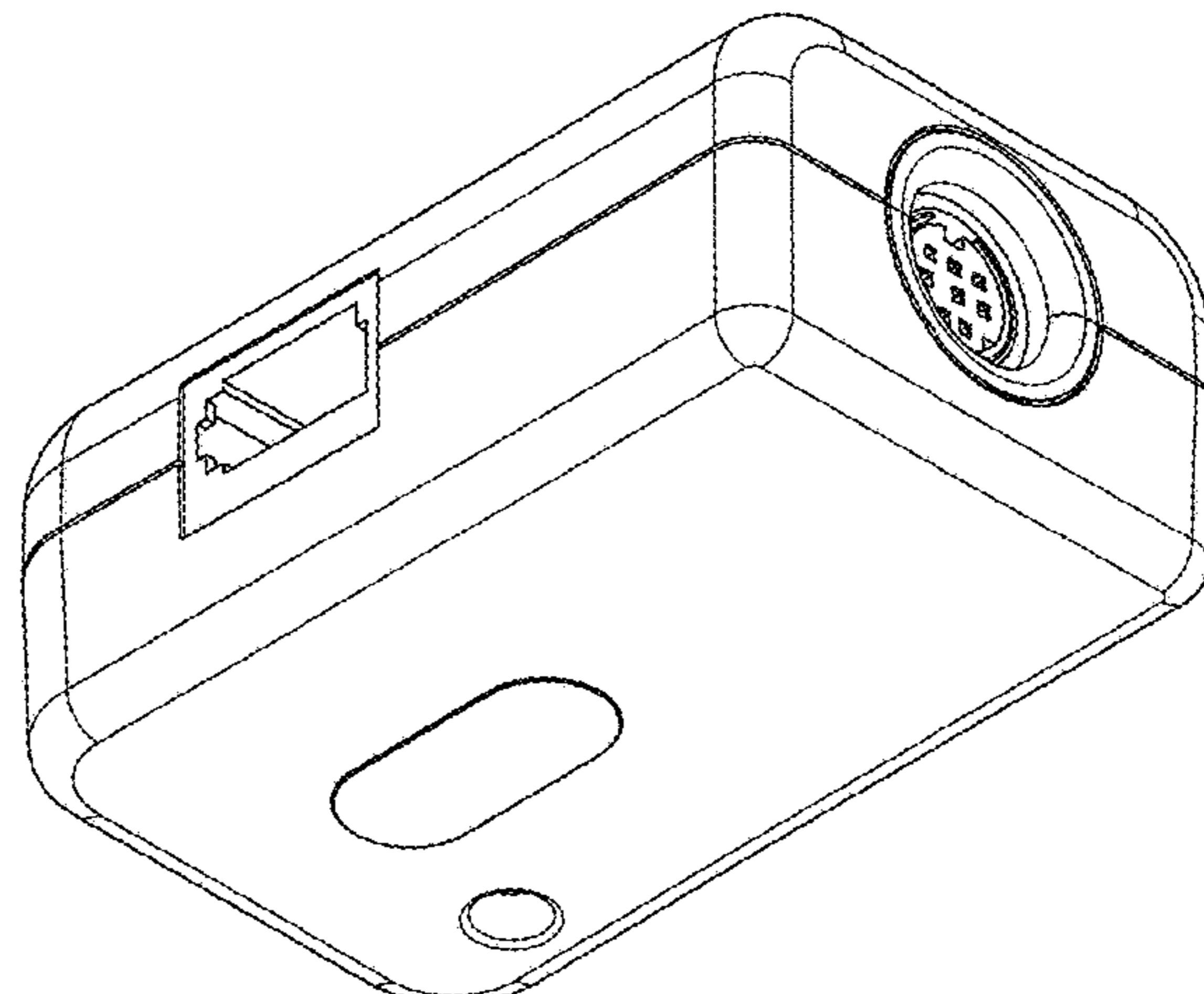
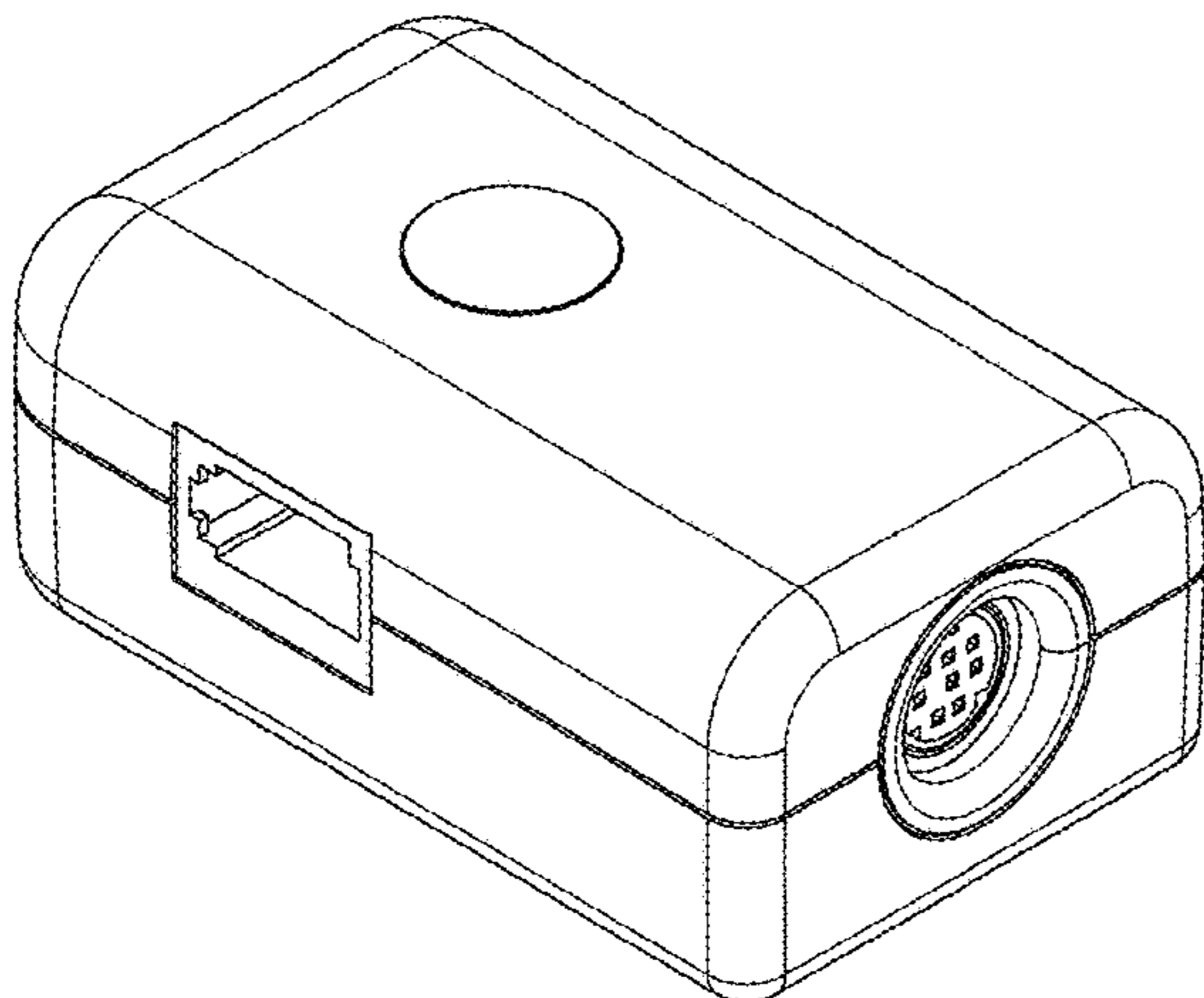

FIG. 1

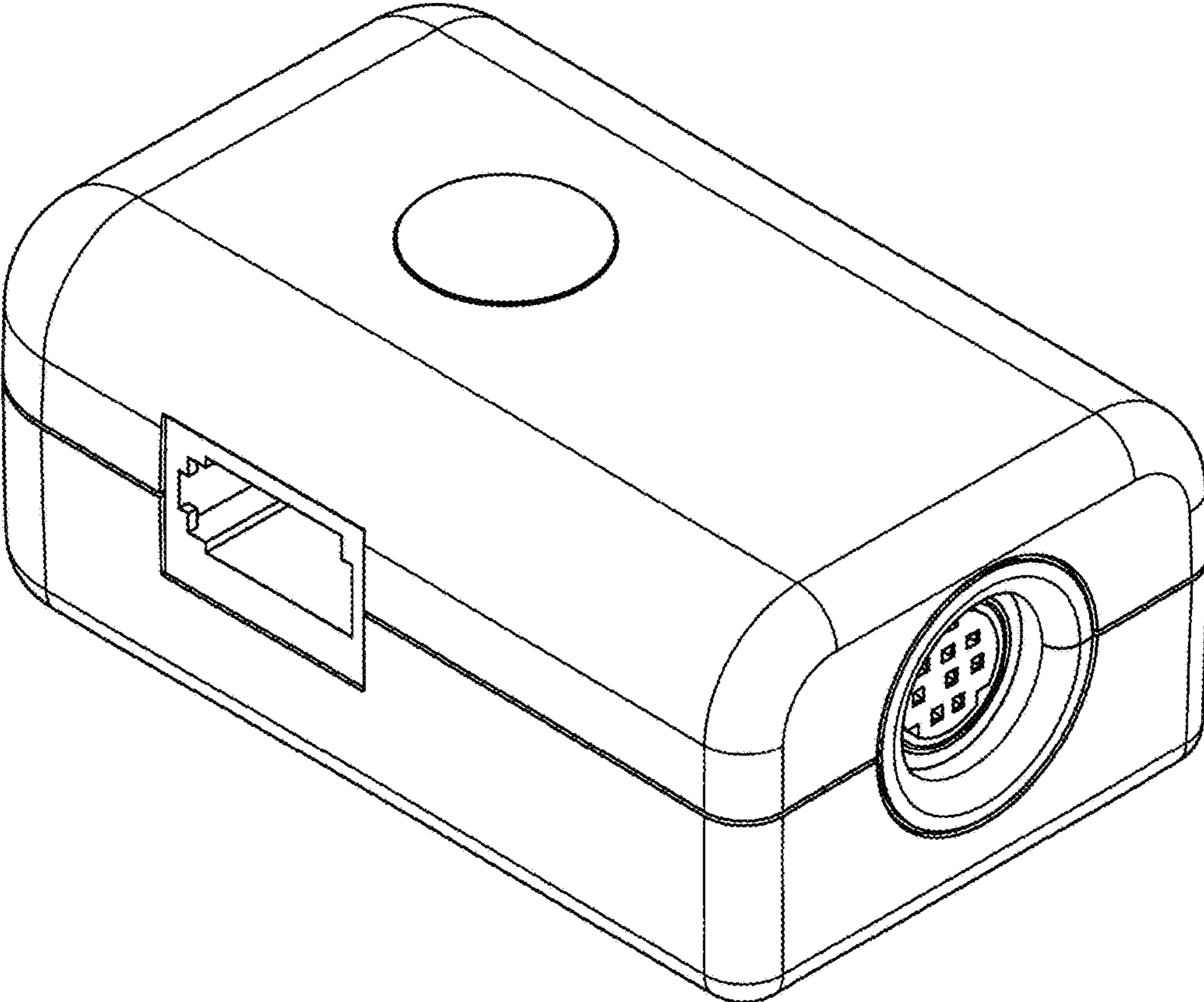

FIG. 2

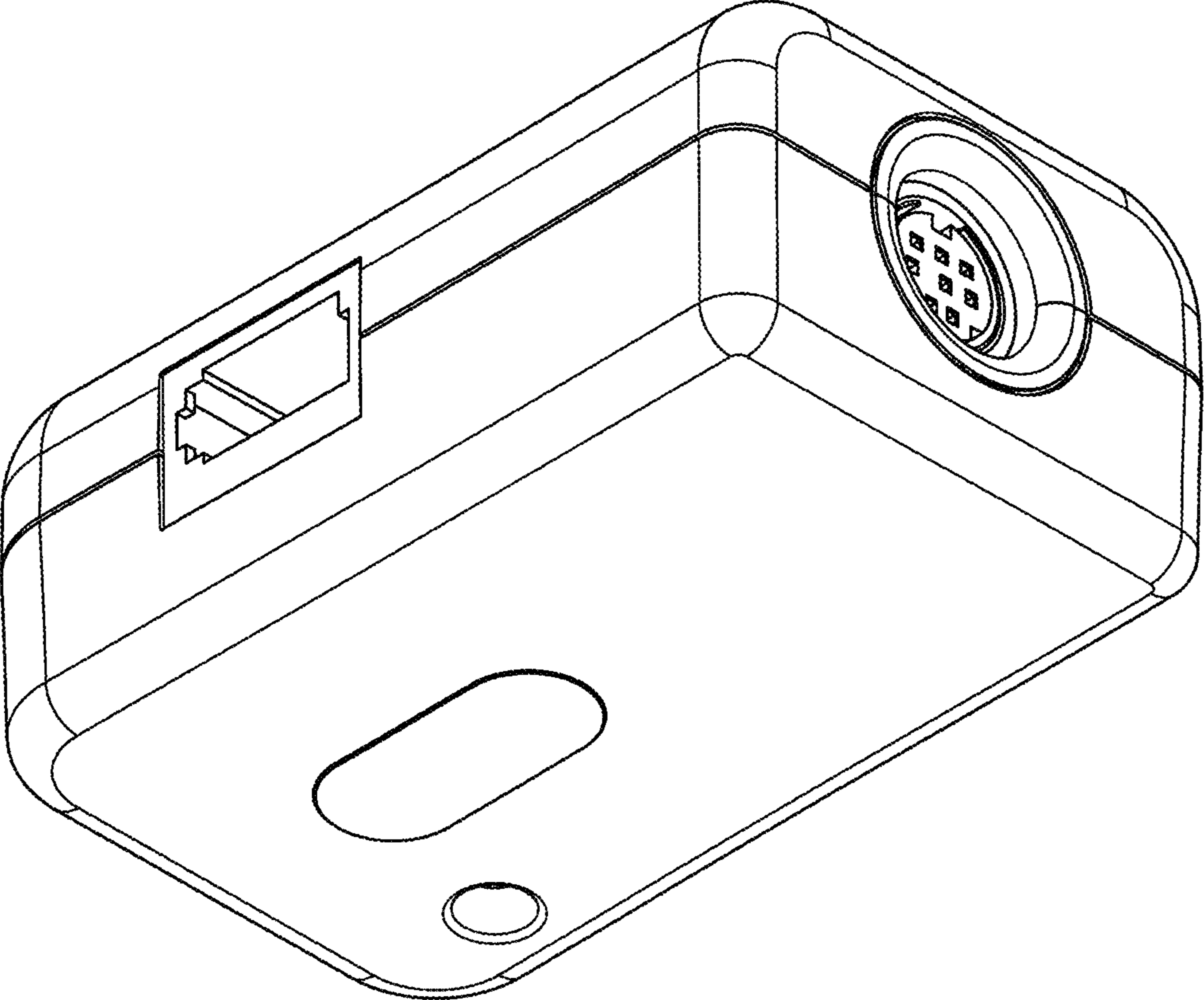

FIG. 3

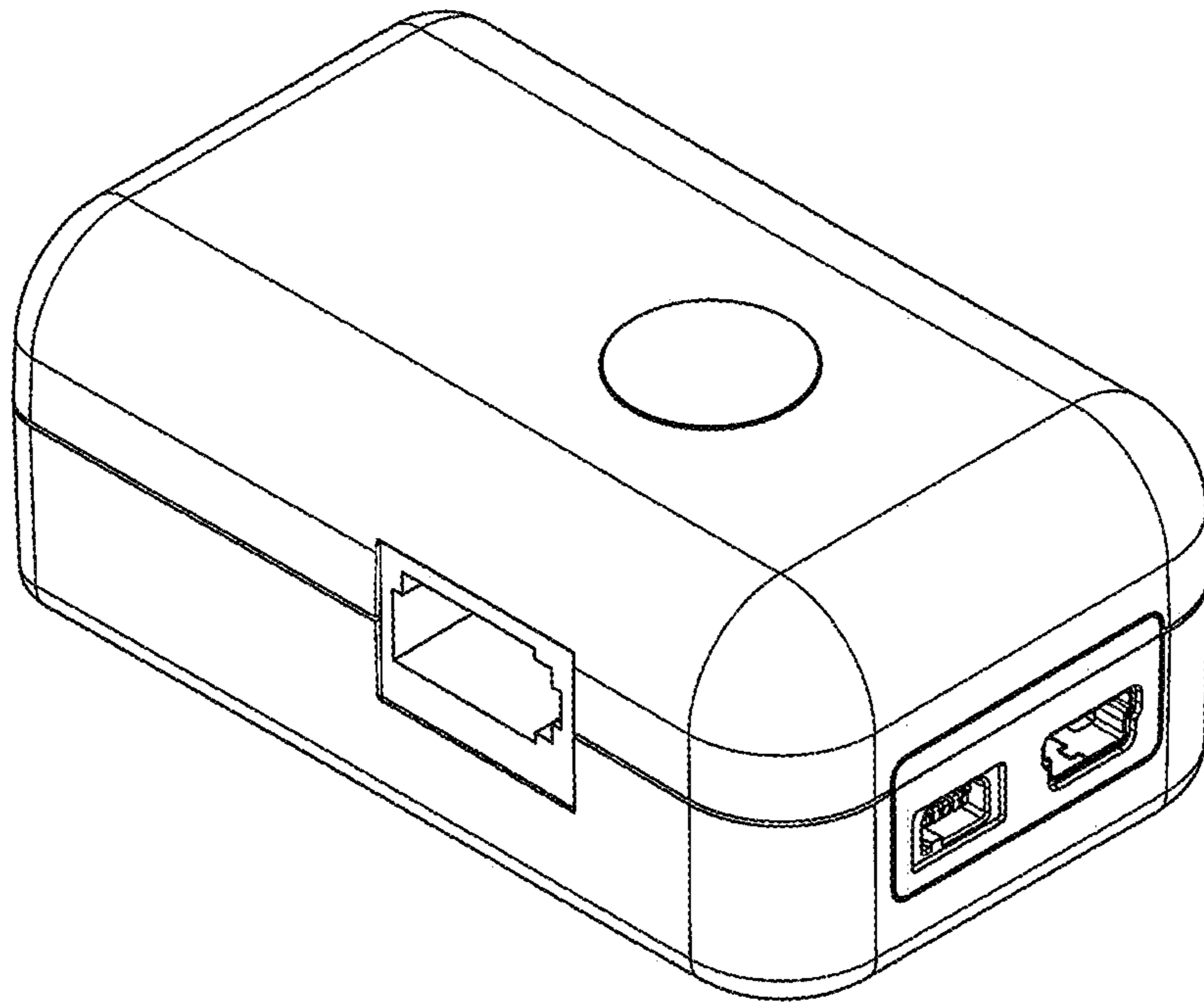

FIG. 4

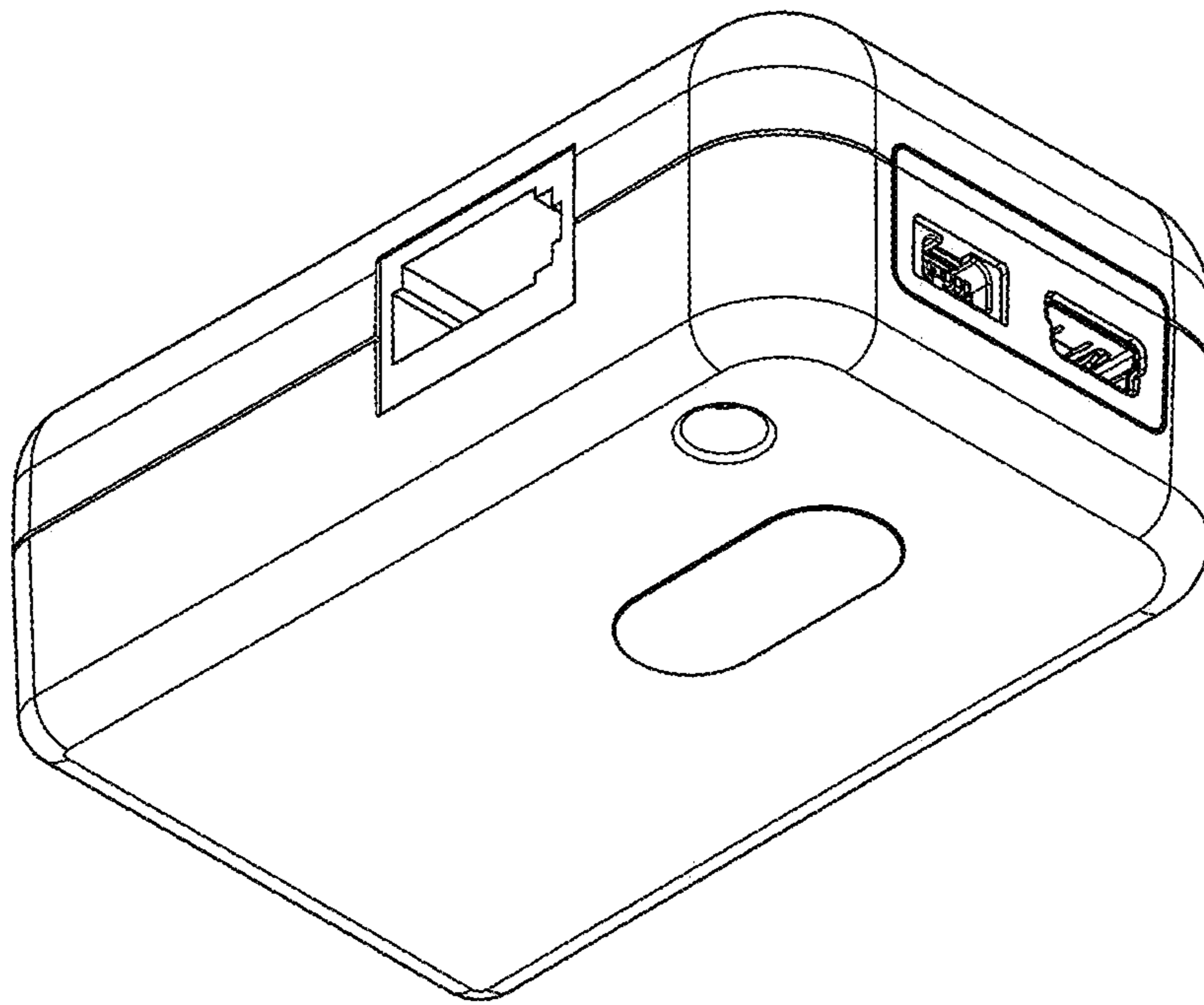

FIG. 5

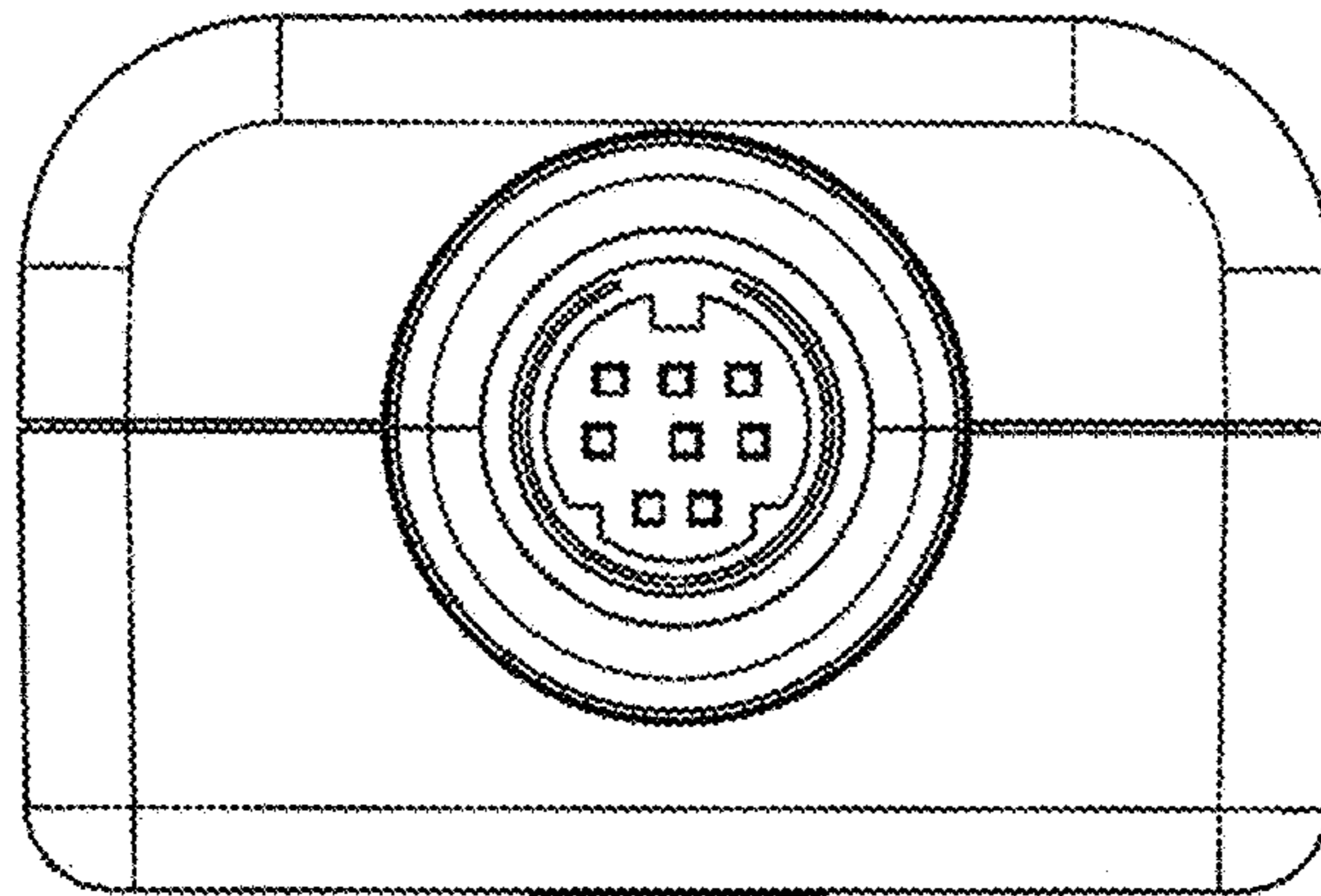

FIG. 6

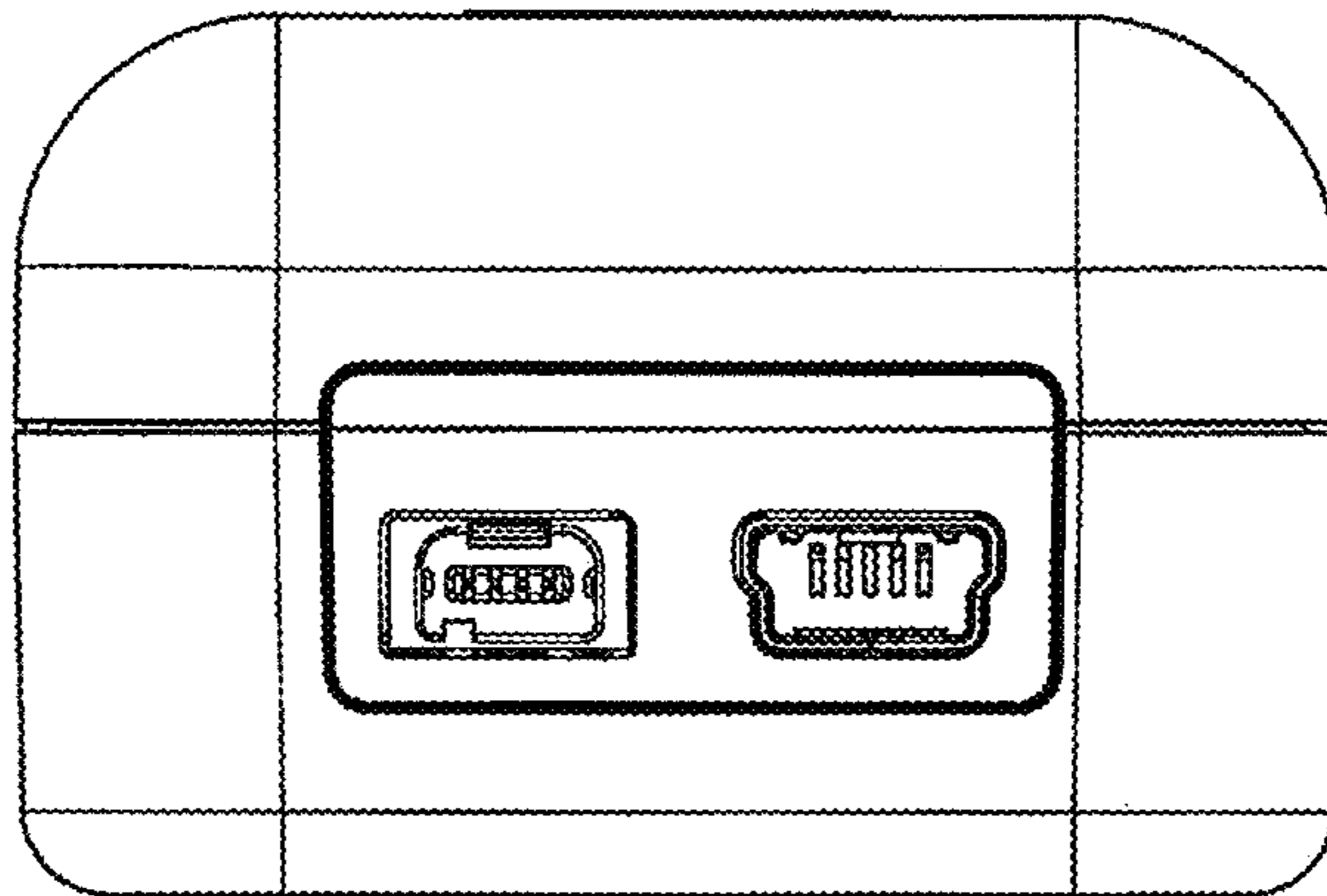

FIG. 7

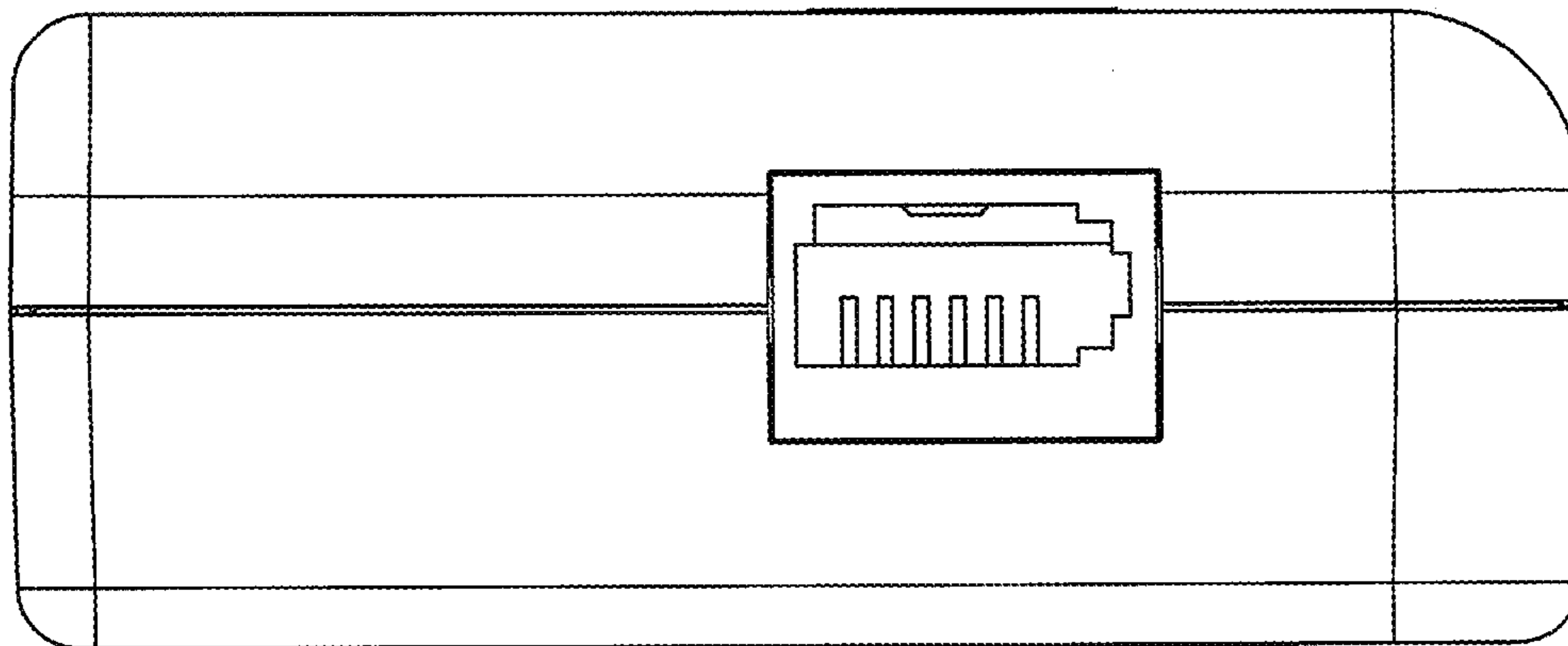



FIG. 8

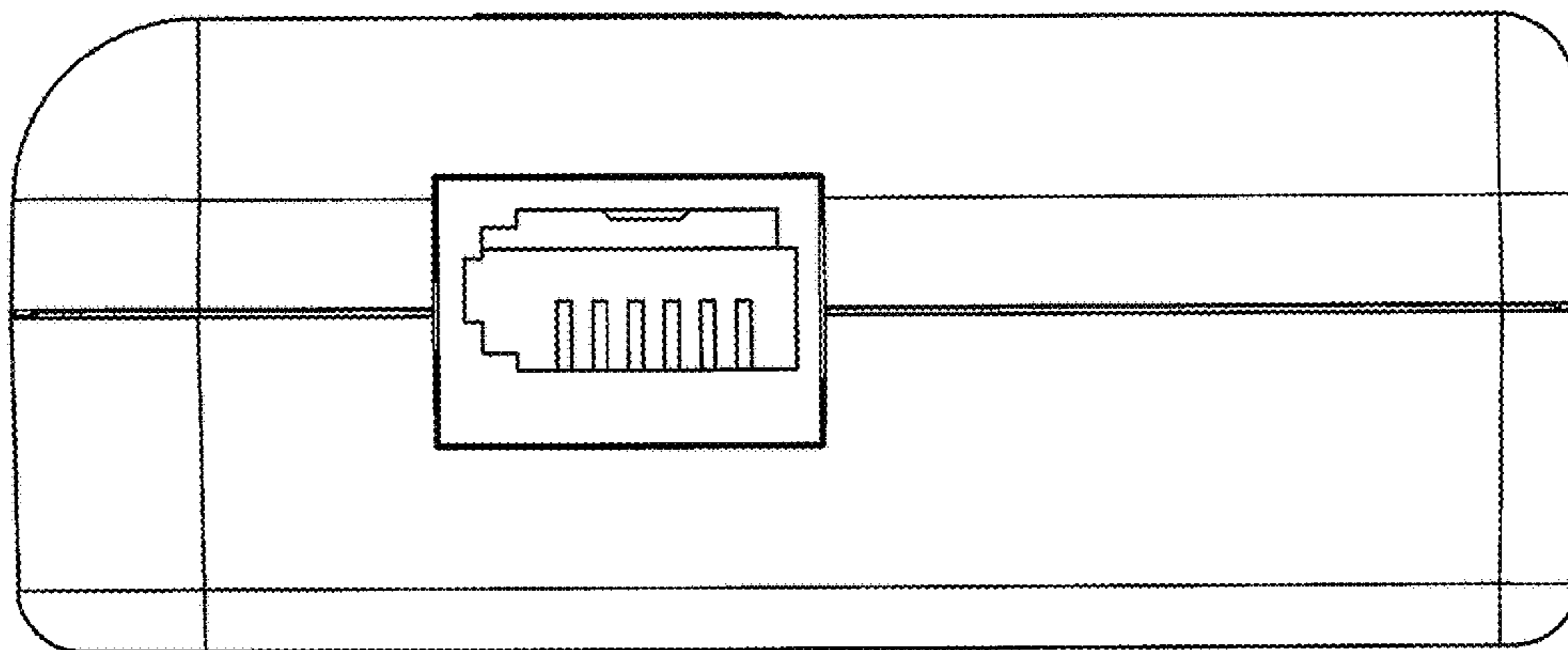

FIG. 9

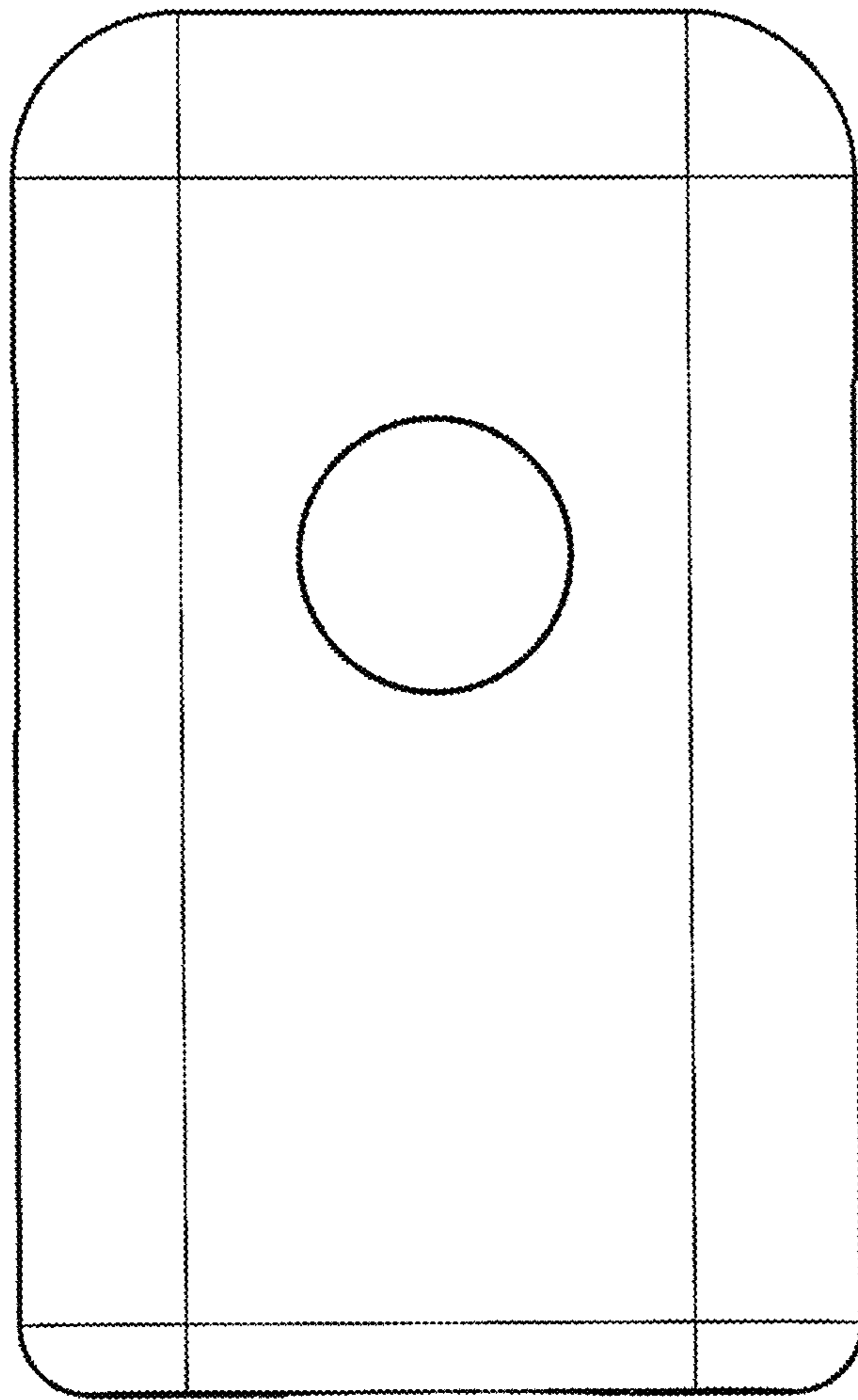

FIG. 10

