



US00D789289S

(12) **United States Design Patent**  
**Sareen**

(10) **Patent No.:** **US D789,289 S**  
(45) **Date of Patent:** **\*\* Jun. 13, 2017**

- (54) **TIRE TREAD**
- (71) Applicant: **Omni United (S) Pte Ltd.**, Singapore (SG)
- (72) Inventor: **Gajendra Singh Sareen**, Singapore (SG)
- (73) Assignee: **Omni United (S) Pte Ltd.**, Singapore (SG)
- (\*\*) Term: **15 Years**
- (21) Appl. No.: **29/565,085**
- (22) Filed: **May 18, 2016**
- (51) **LOC (10) Cl.** ..... **12-15**
- (52) **U.S. Cl.**  
USPC ..... **D12/596**
- (58) **Field of Classification Search**  
USPC ..... D12/579, 596, 597, 599, 600, 602, 603, D12/604  
CPC . B60C 11/03; B60C 11/0306; B60C 11/0311; B60C 11/0323; B60C 2011/0344; B60C 2011/0346; B60C 2011/0374  
See application file for complete search history.

D471,492 S	3/2003	Slingluff et al.	
D591,227 S *	4/2009	Seibert .....	D12/602
D591,228 S	4/2009	Seibert et al.	
D603,788 S	11/2009	Lundgren	
D626,912 S	11/2010	Fujita et al.	
D635,088 S	3/2011	Sareen	
D637,152 S	5/2011	Maus et al.	
D645,397 S	9/2011	Sareen	
D651,968 S	1/2012	Westaway	
D660,224 S	5/2012	Takahashi	
D661,643 S	6/2012	Kaji	
D726,644 S	4/2015	Kuwahara	
D735,121 S *	7/2015	Sareen .....	D12/600
D760,641 S *	7/2016	Colombo .....	D12/588

\* cited by examiner

*Primary Examiner* — Robert M Spear  
(74) *Attorney, Agent, or Firm* — Perkins Coie LLP

(57) **CLAIM**

The ornamental design for a tire tread, as shown and described.

**DESCRIPTION**

FIG. 1 is a perspective view of a tire tread, showing my new design;  
 FIG. 2 is a front view thereof;  
 FIG. 3 is a side view thereof;  
 FIG. 4 is an enlarged perspective view of a section of the tire tread defined by lines 4-4 in FIG. 1;  
 FIG. 5 is an enlarged front view of a section of the tire tread as defined by lines 5-5 in FIG. 2; and,  
 FIG. 6 is an enlarged side view of a section of the tire tread as defined by lines 6-6 in FIG. 3.  
 The broken lines in FIGS. 1-6 show portions of the tire which form no part of the claimed design.

**1 Claim, 6 Drawing Sheets**

(56) **References Cited**

**U.S. PATENT DOCUMENTS**

D265,303 S	7/1982	Yokoyama	
D316,692 S	5/1991	Fukumoto	
D328,577 S *	8/1992	Goergen .....	D12/597
D336,453 S *	6/1993	Patel .....	D12/596
D370,439 S	6/1996	Feider et al.	
D384,611 S *	10/1997	Harden, Jr. ....	D12/597
D385,832 S	11/1997	Lim et al.	
D388,369 S *	12/1997	Harden, Jr. ....	D12/596
D444,740 S *	7/2001	Le .....	D12/602

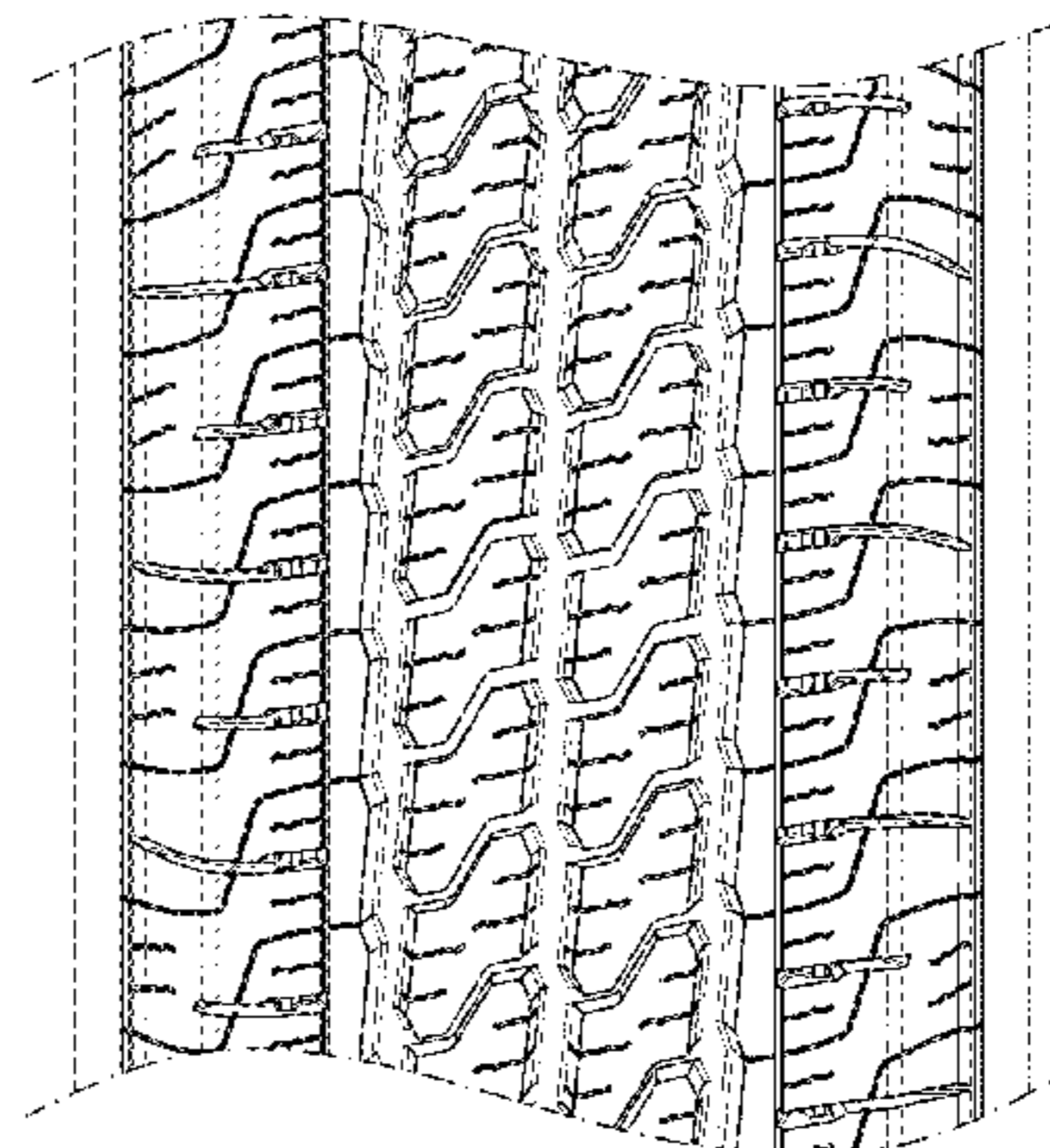
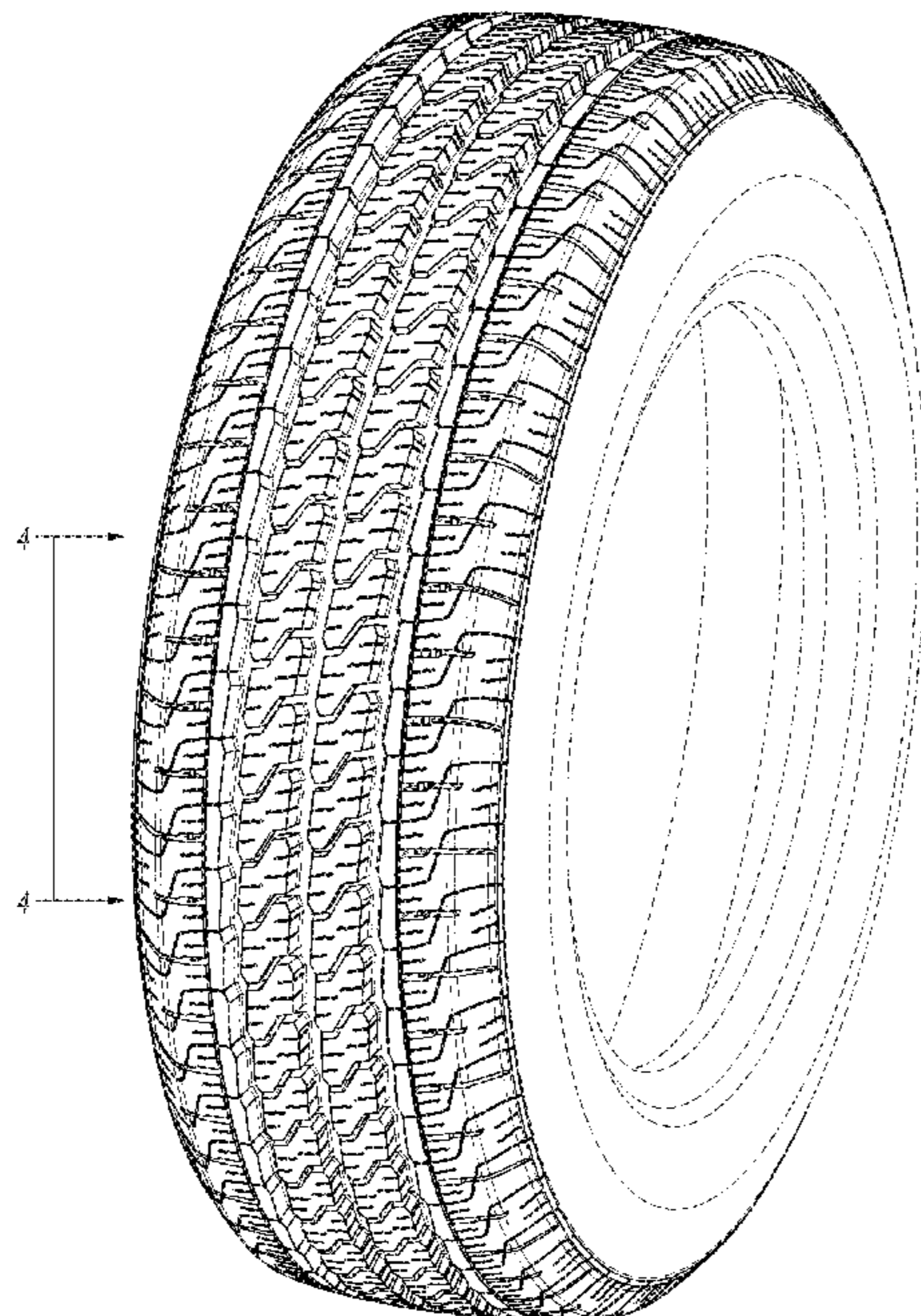

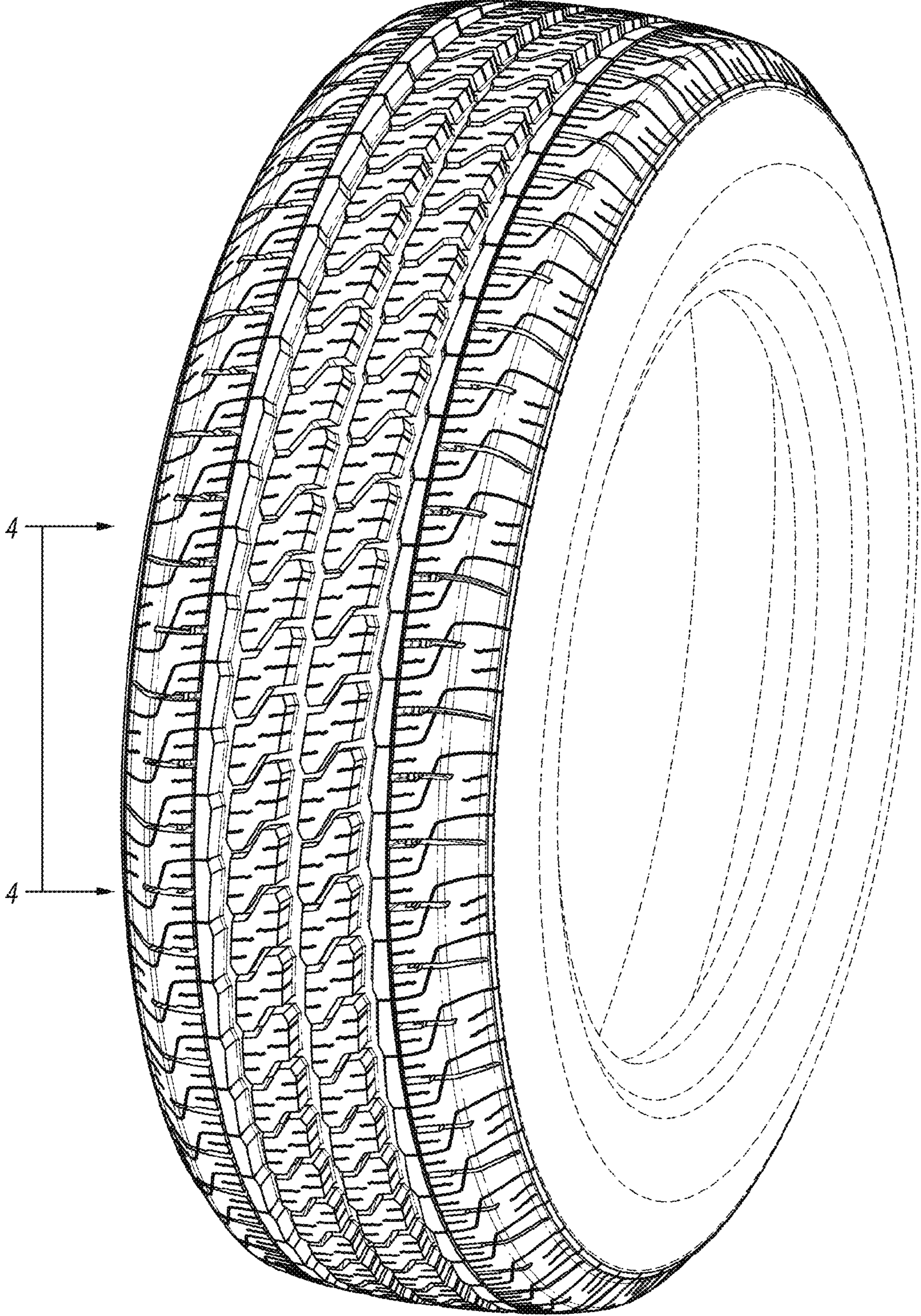

FIG. 1

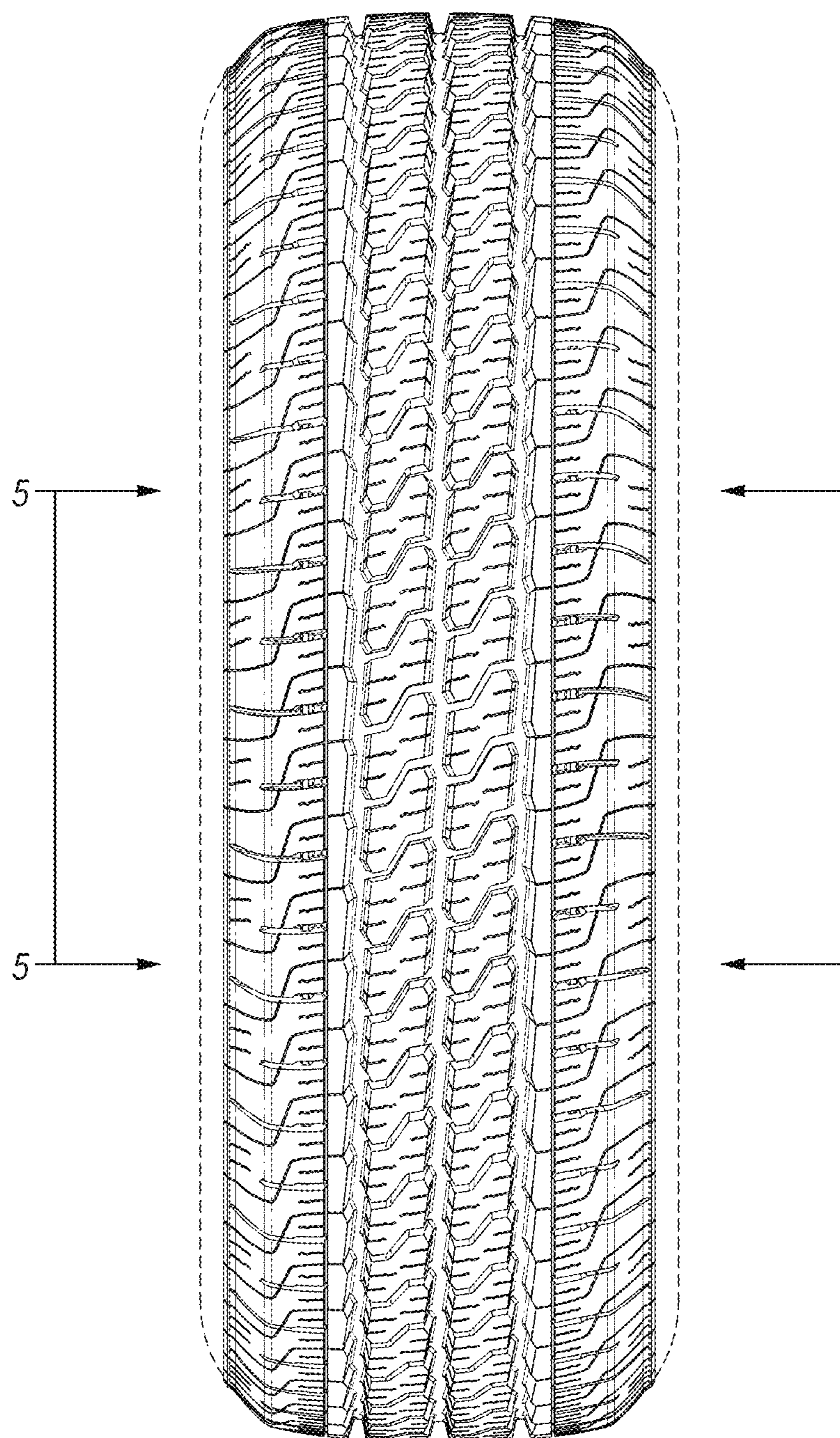

FIG. 2

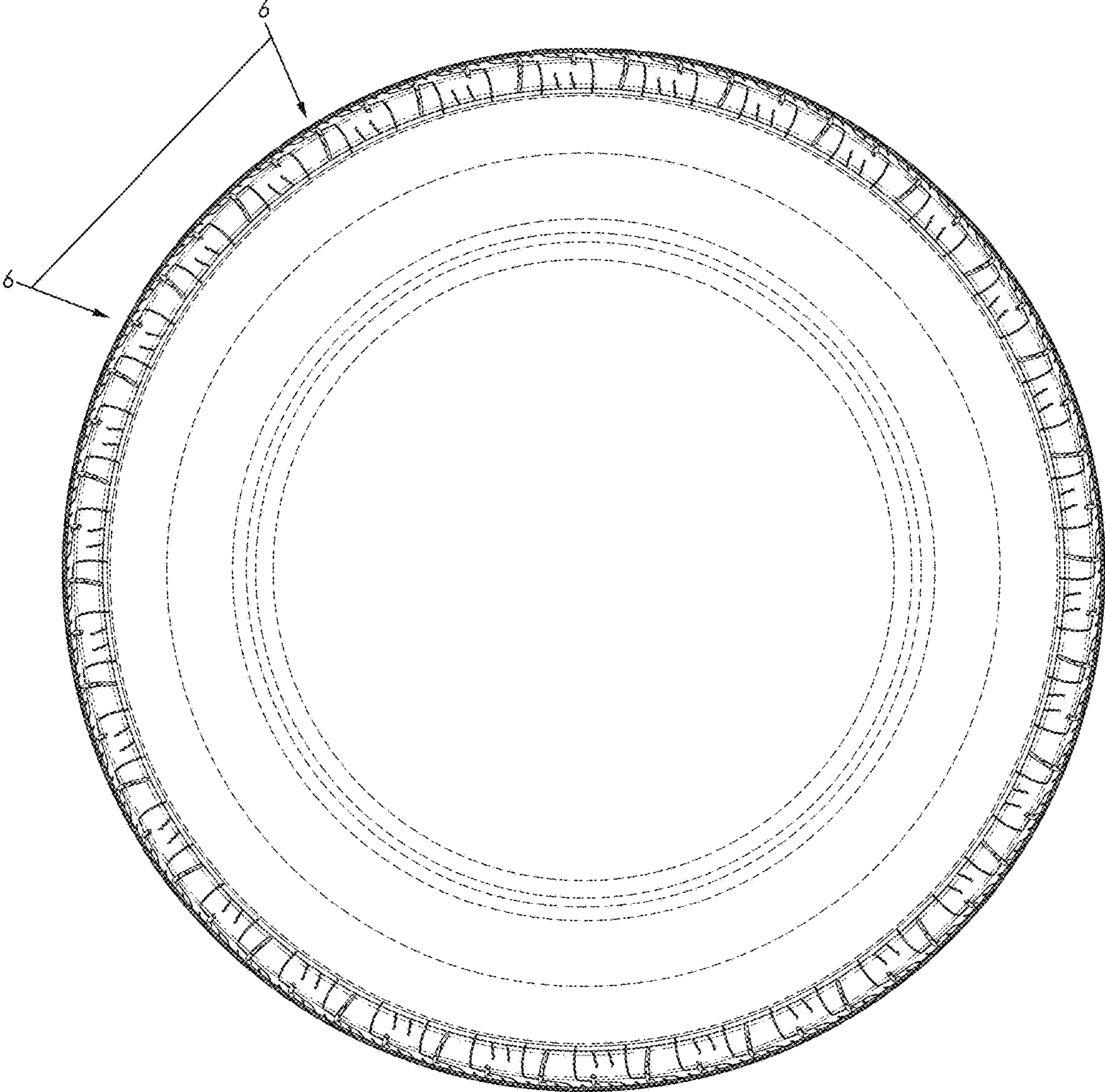

FIG. 3

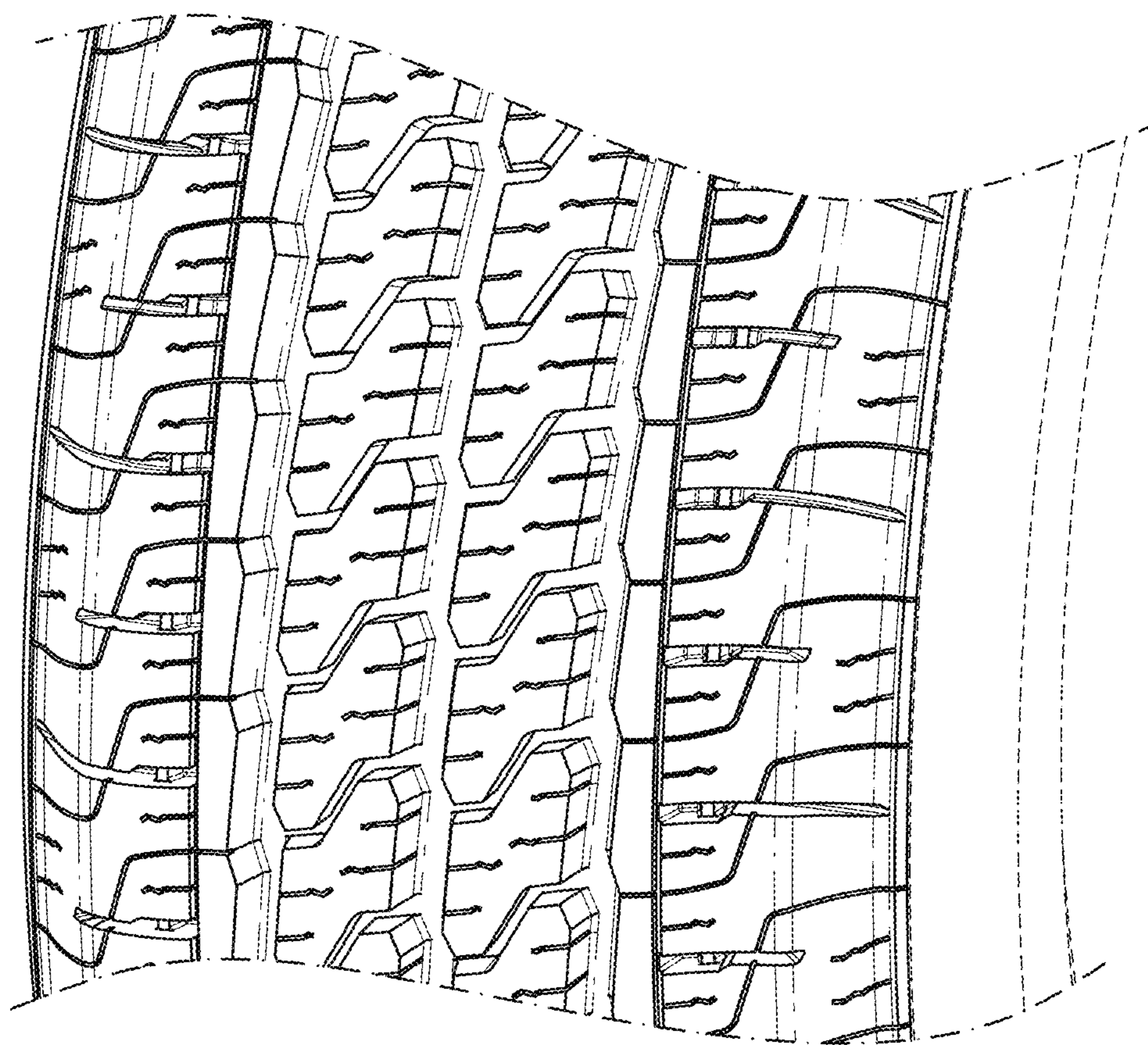

FIG. 4

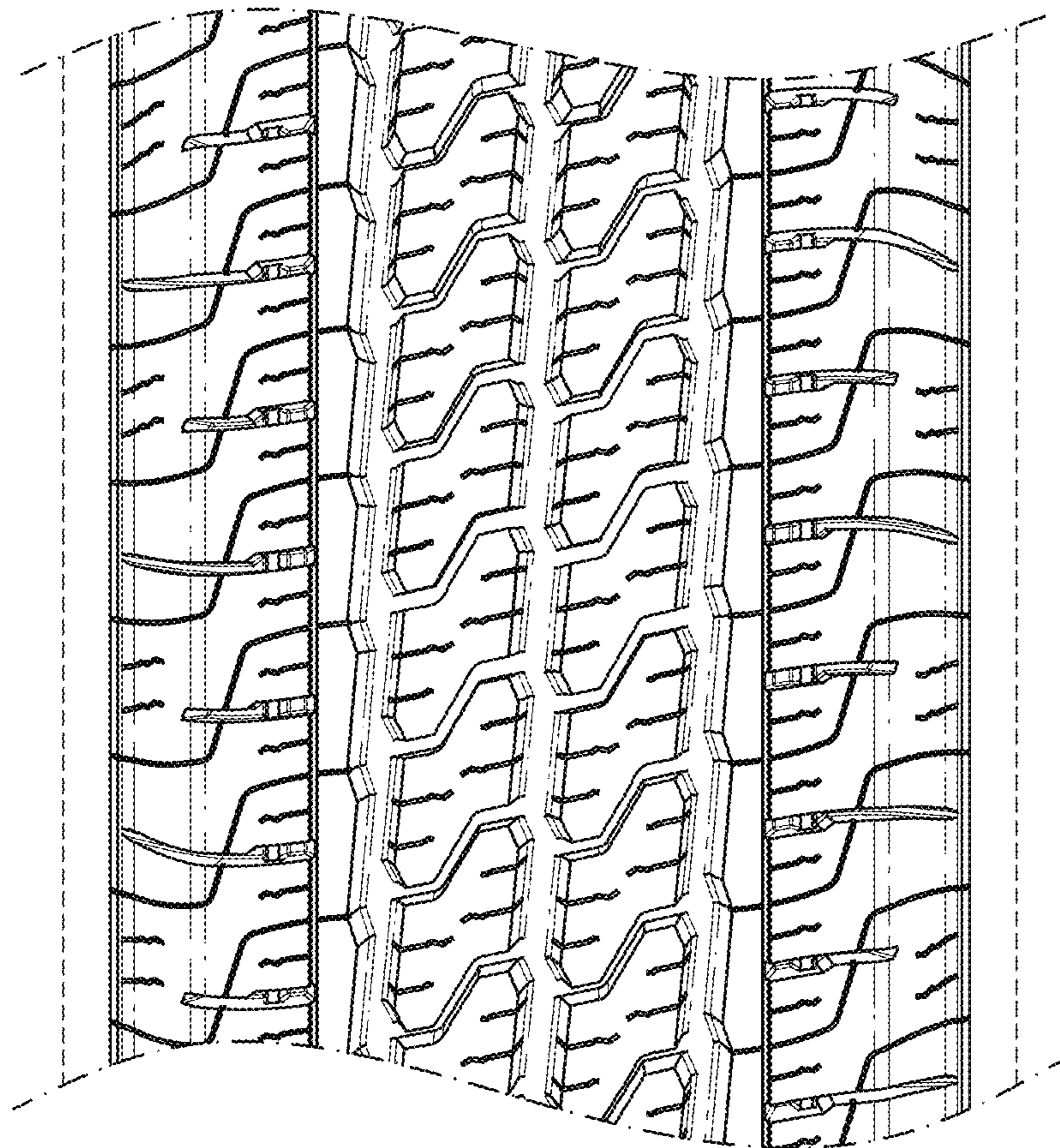

FIG. 5

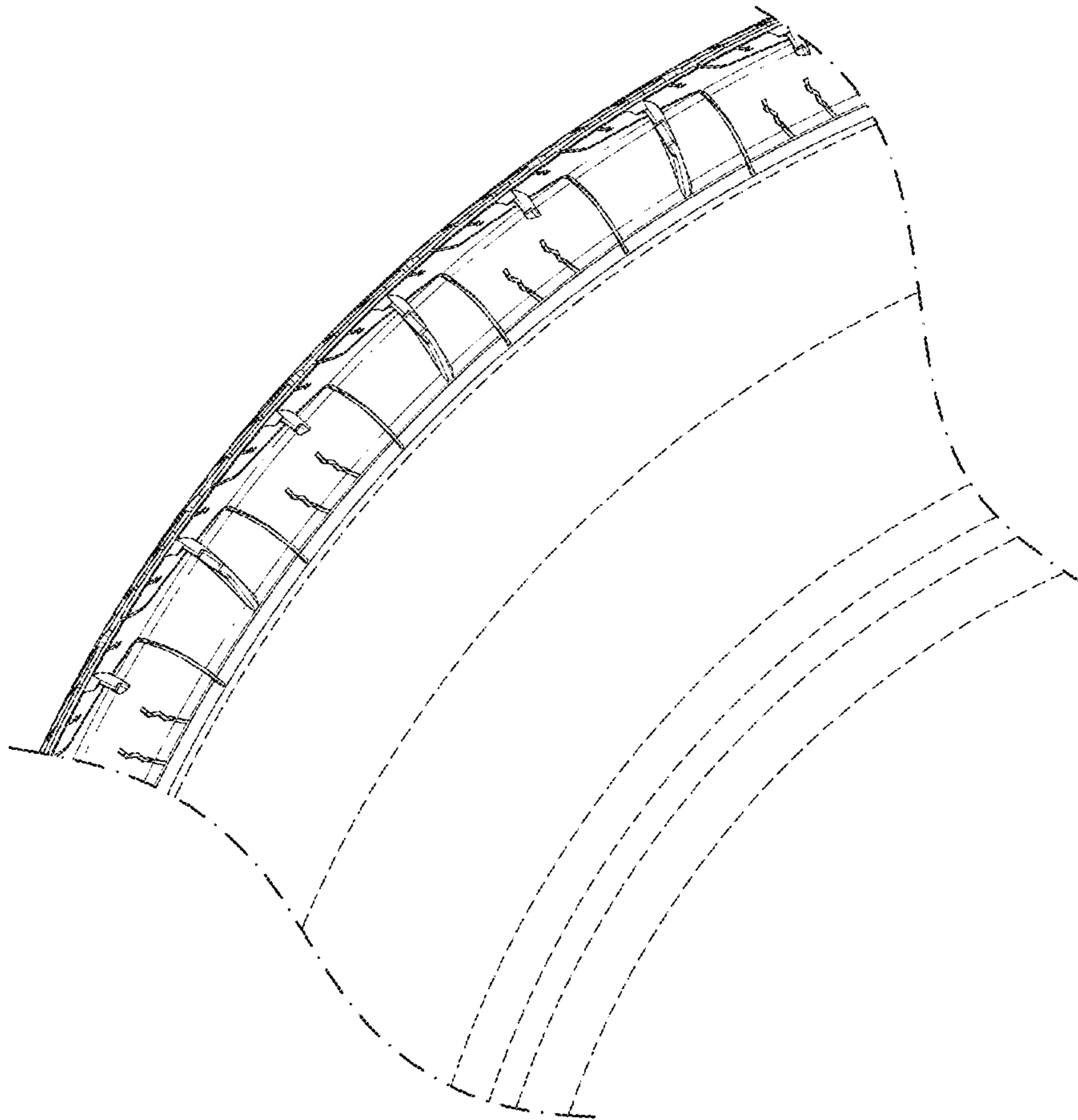

FIG. 6