



US00D789275S

(12) **United States Design Patent**  
**Richie**

(10) **Patent No.:** **US D789,275 S**  
(45) **Date of Patent:** **\*\* Jun. 13, 2017**

(54) **SADDLEBAG EXTENSIONS**

(71) Applicant: **John Evans Richie**, Miami, FL (US)

(72) Inventor: **John Evans Richie**, Miami, FL (US)

(\*\*) Term: **14 Years**

(21) Appl. No.: **29/512,820**

(22) Filed: **Dec. 23, 2014**

(51) **LOC (10) Cl.** ..... **12-16**

(52) **U.S. Cl.**

USPC ..... **D12/407**

(58) **Field of Classification Search**

USPC ..... D12/186, 410, 114, 409

CPC ..... B62J 9/00; B62J 15/00; B62J 9/001; B62J  
15/02; B62K 5/01

See application file for complete search history.

(56) **References Cited**

**U.S. PATENT DOCUMENTS**

D550,146 S	9/2007	Hanagan	
7,278,560 B2 *	10/2007	Aron	B62J 9/00 224/413
D595,617 S *	7/2009	Million	D12/114
D664,074 S	7/2012	Clarkson	
D722,945 S *	2/2015	Richie	D12/407

\* cited by examiner

*Primary Examiner* — Michael A Pratt

(74) *Attorney, Agent, or Firm* — Tracy Jong Law Firm;  
Tracy P. Jong; Cheng Ning Jong

(57) **CLAIM**

The ornamental design for saddlebag extensions, as shown and described.

**DESCRIPTION**

This divisional application claims the benefit of priority from non-provisional application U.S.S.N. Ser. No. 29/456, 925 filed on Jun. 5, 2013. Said application is incorporated by reference in its entirety.

FIG. 1 is a top right rear perspective view of a motorcycle, drawn in broken lines, showing the ornamental design of the exterior surfaces of the saddlebag extensions in use;

FIG. 2 is a right elevation view of the saddlebag extensions shown in use with a saddlebag of a motorcycle drawn in broken lines;

FIG. 3 is a top right rear perspective view of the saddlebag extensions shown in use with saddlebags of a motorcycle drawn in broken lines;

FIG. 4 is a top right rear perspective view of the saddlebag extensions, depicting the left and right saddlebag extensions as they are removed from their respective saddlebags drawn in broken lines;

FIG. 5 is a right elevation view of the right saddlebag extension;

FIG. 6 is a left elevation view thereof;

FIG. 7 is a front elevation view of the saddlebag extensions;

FIG. 8 is a rear elevation view thereof.

FIG. 9 is a top plan view thereof; and,

FIG. 10 is a bottom plan view thereof.

The single dashed lines represent parts of a motorcycle and form no part of the claim.

**1 Claim, 6 Drawing Sheets**

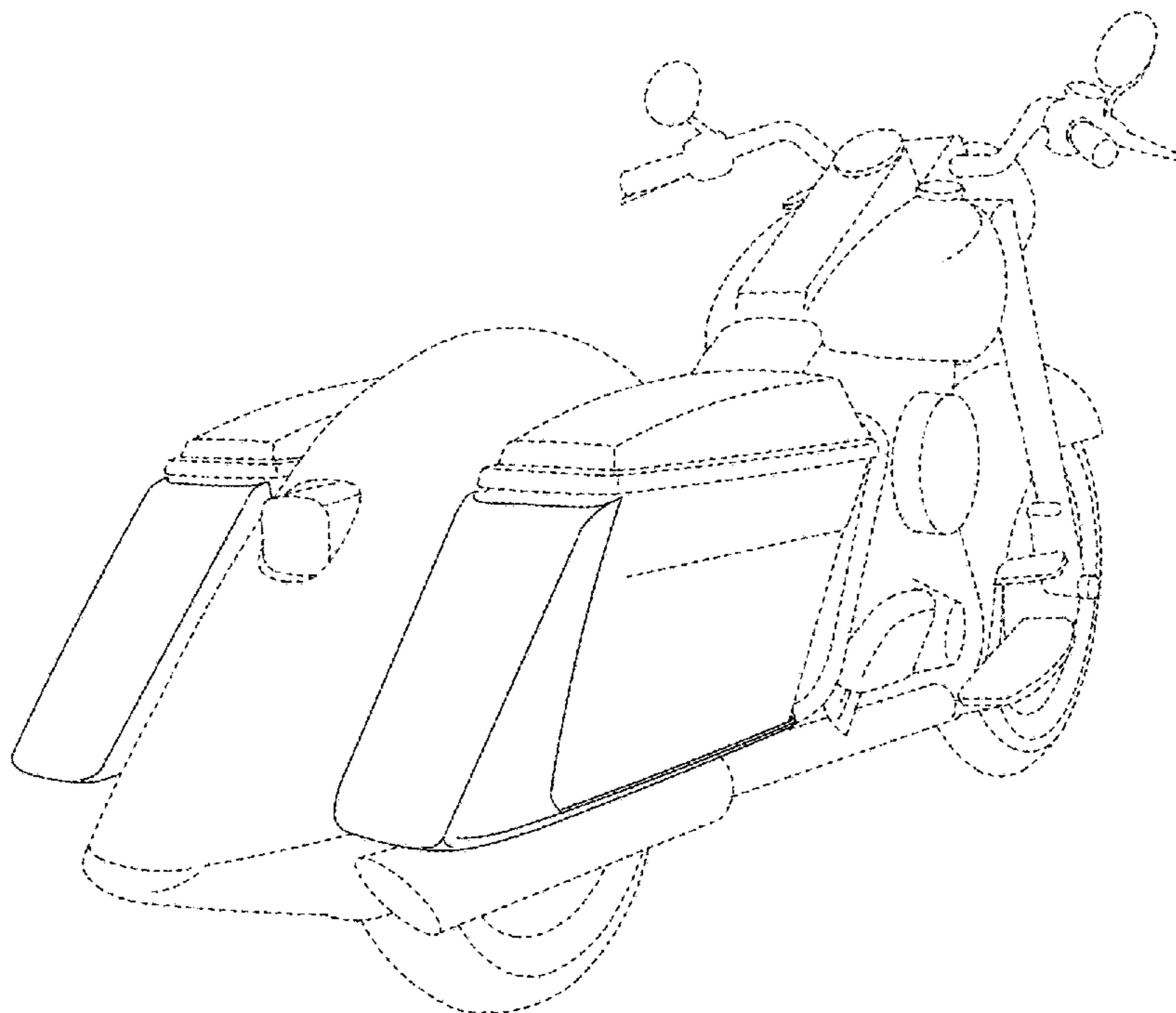

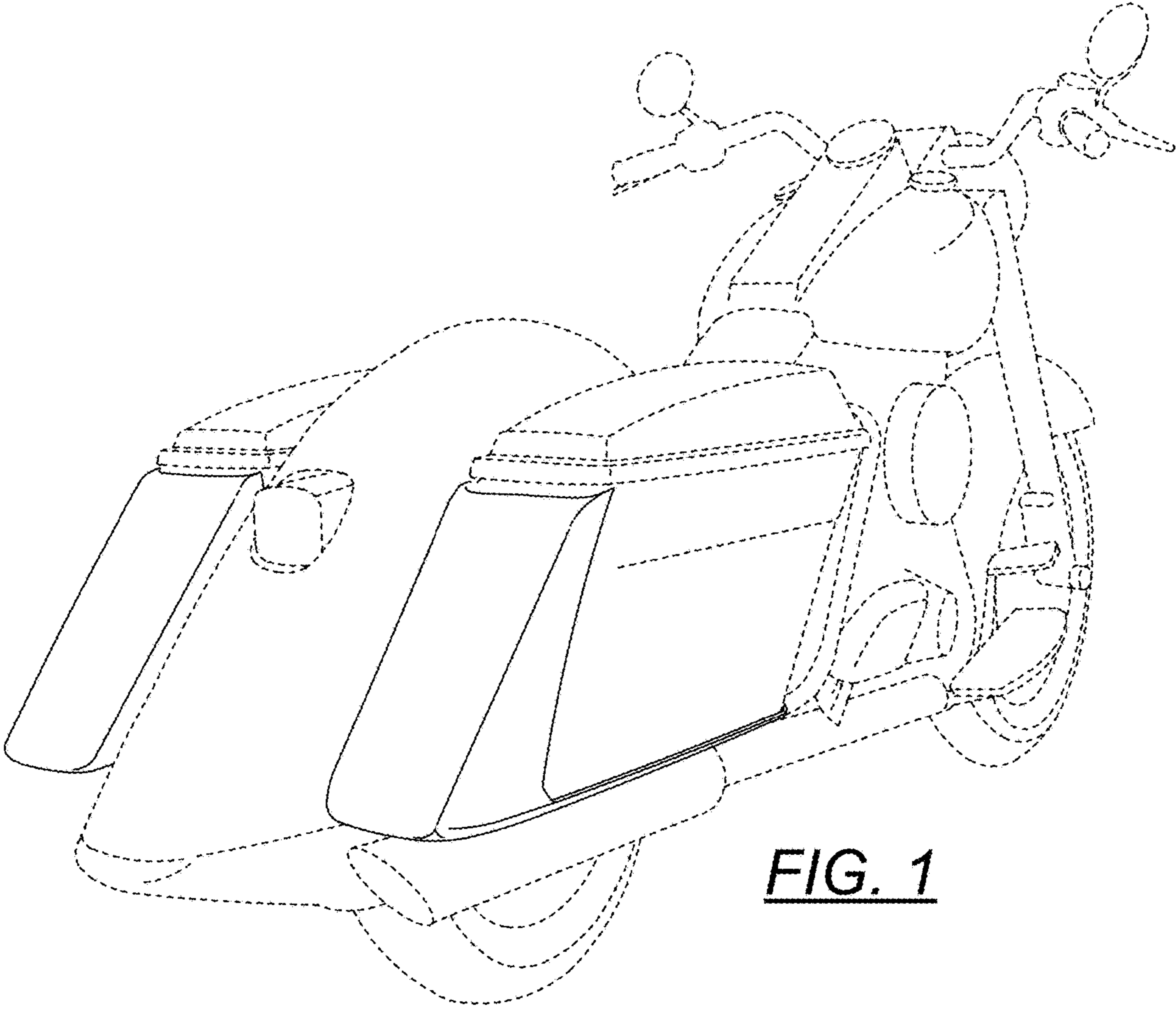

FIG. 1

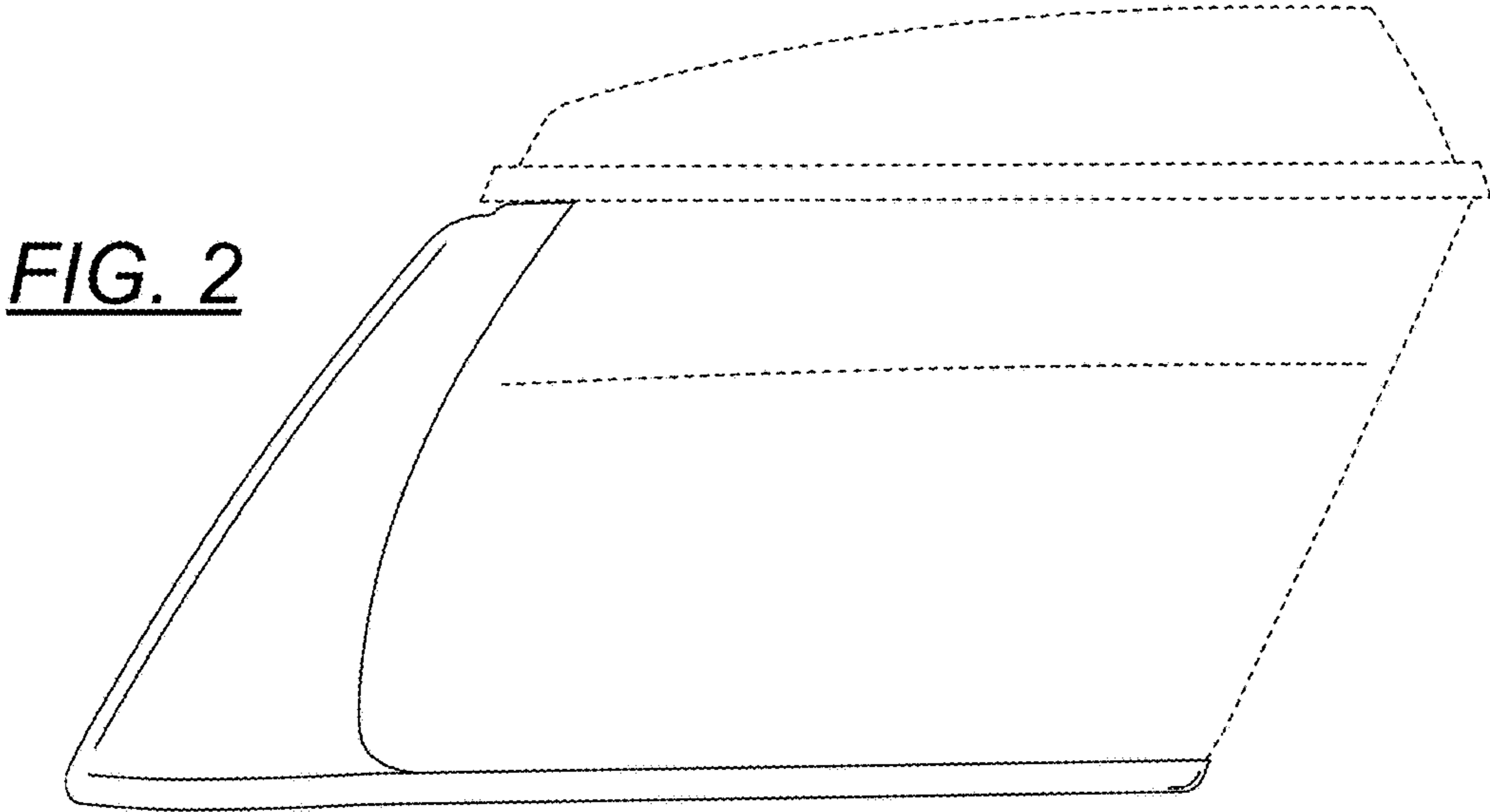

FIG. 2

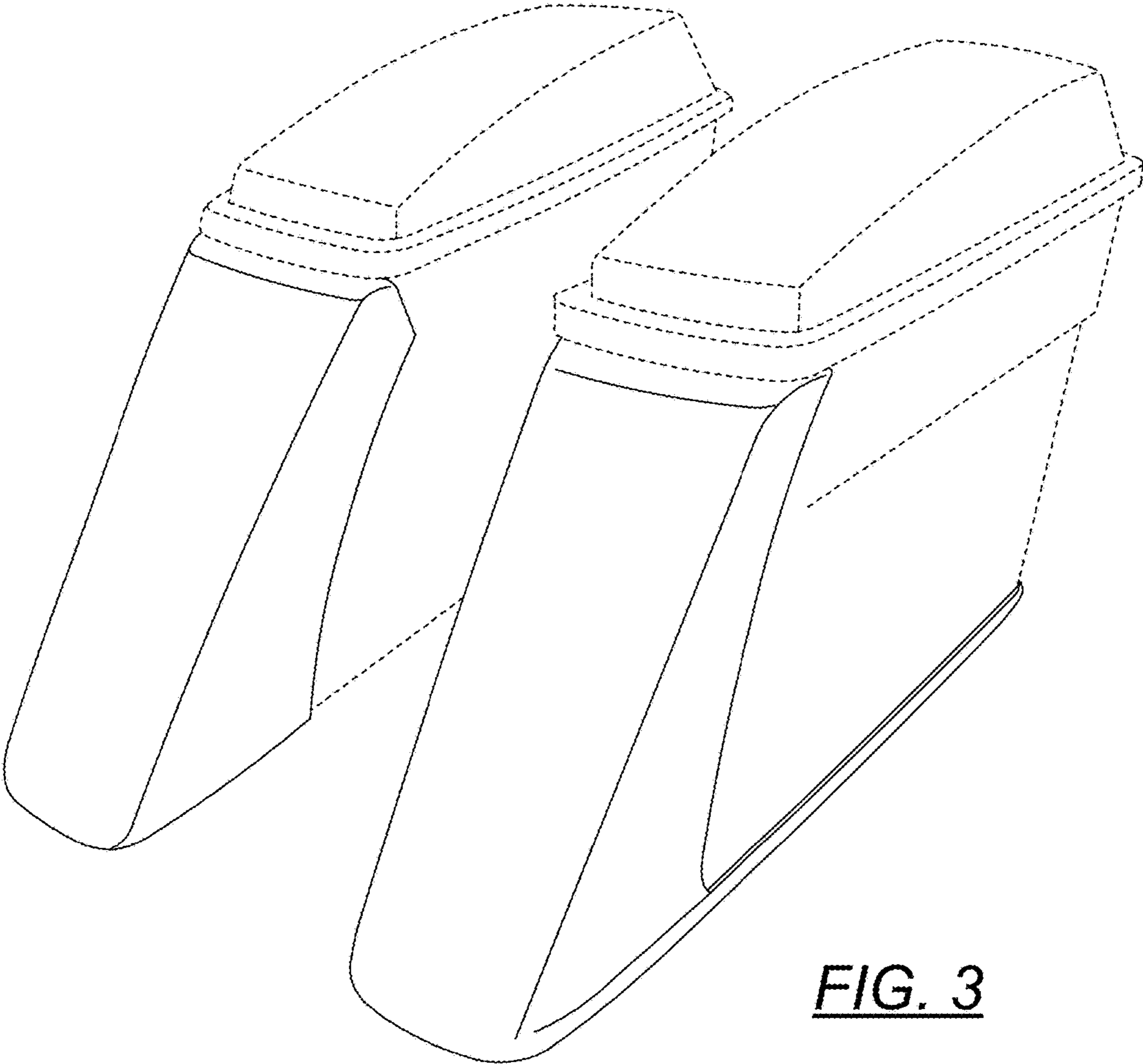

FIG. 3

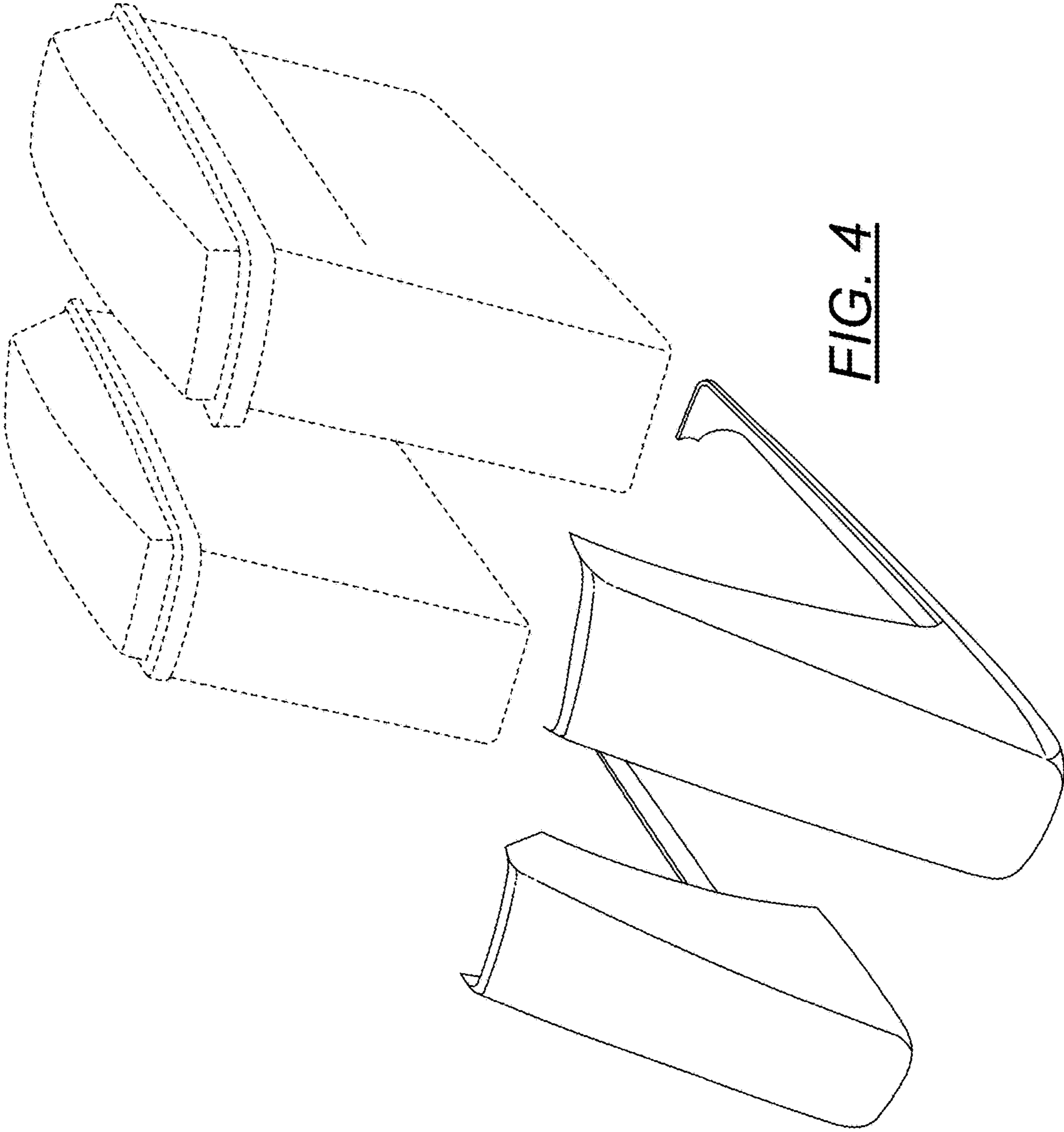

FIG. 4

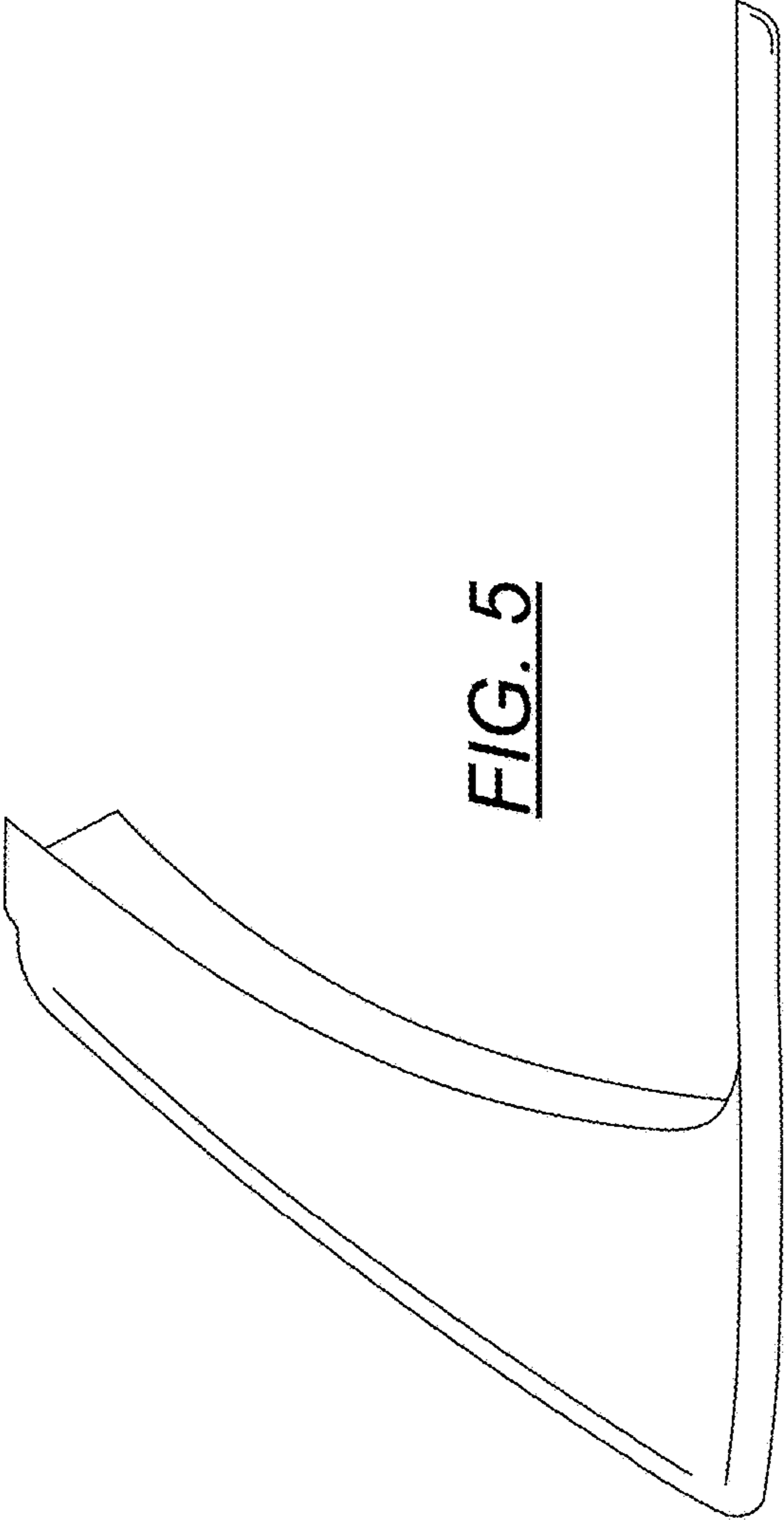

FIG. 5

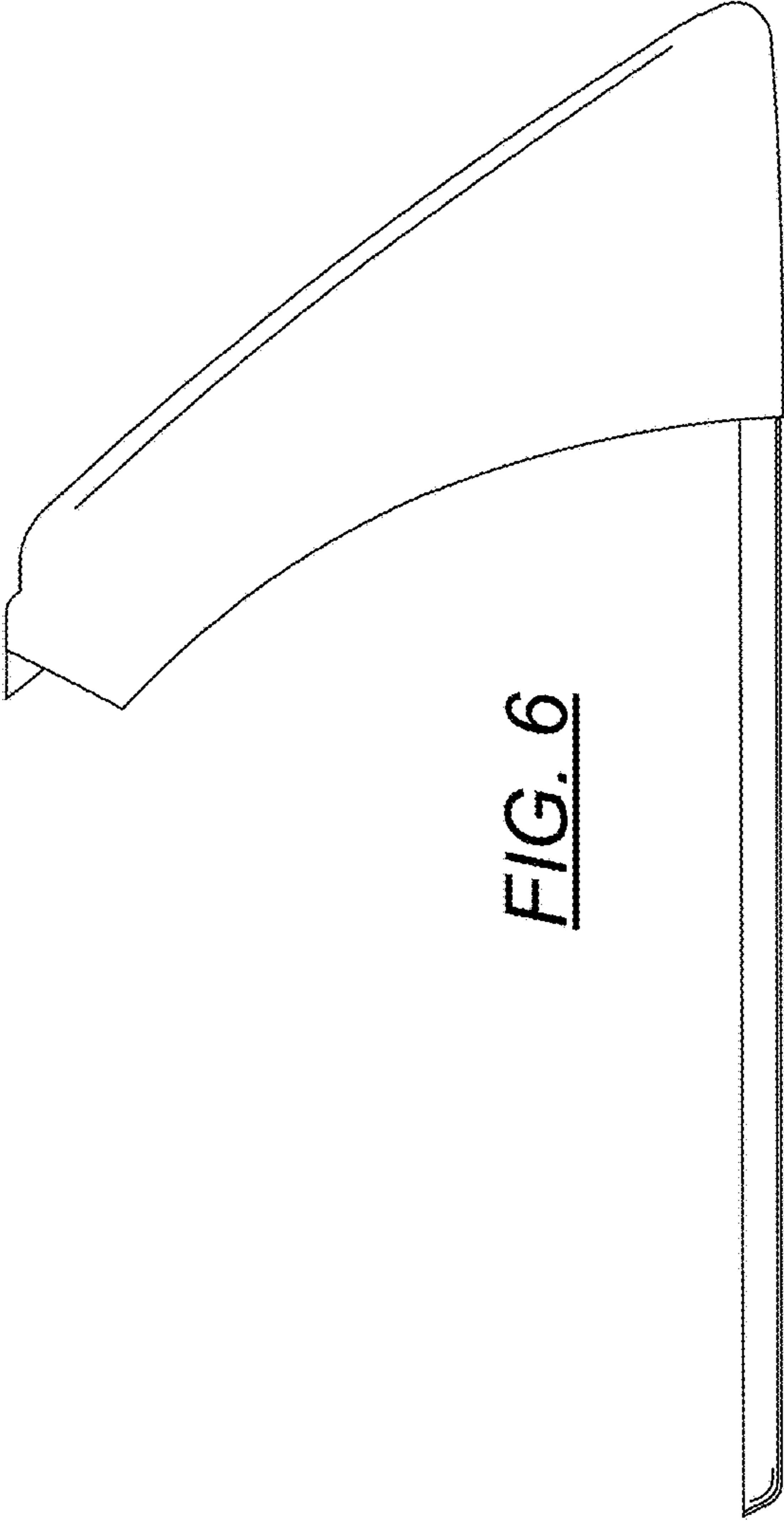

FIG. 6

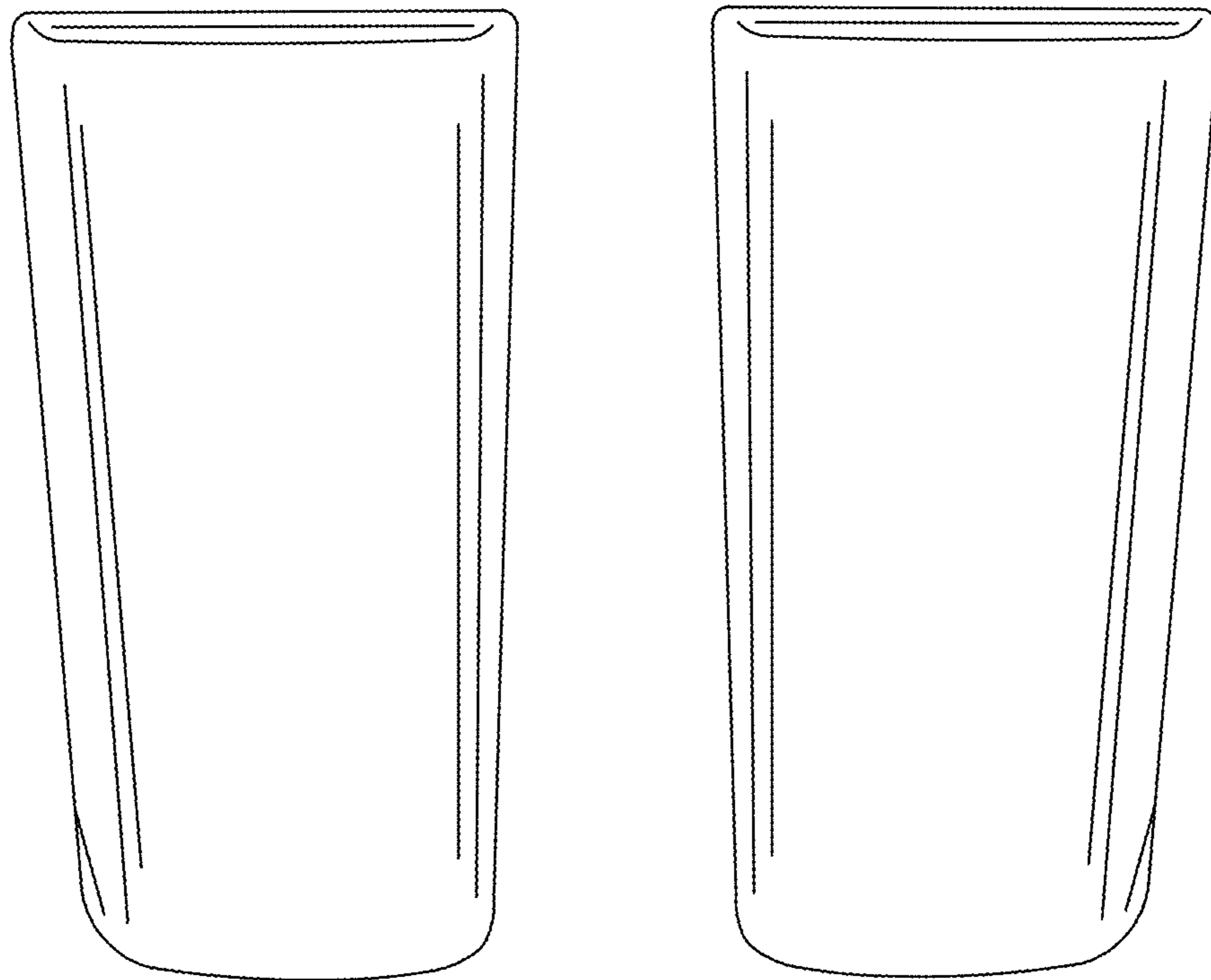

FIG. 7

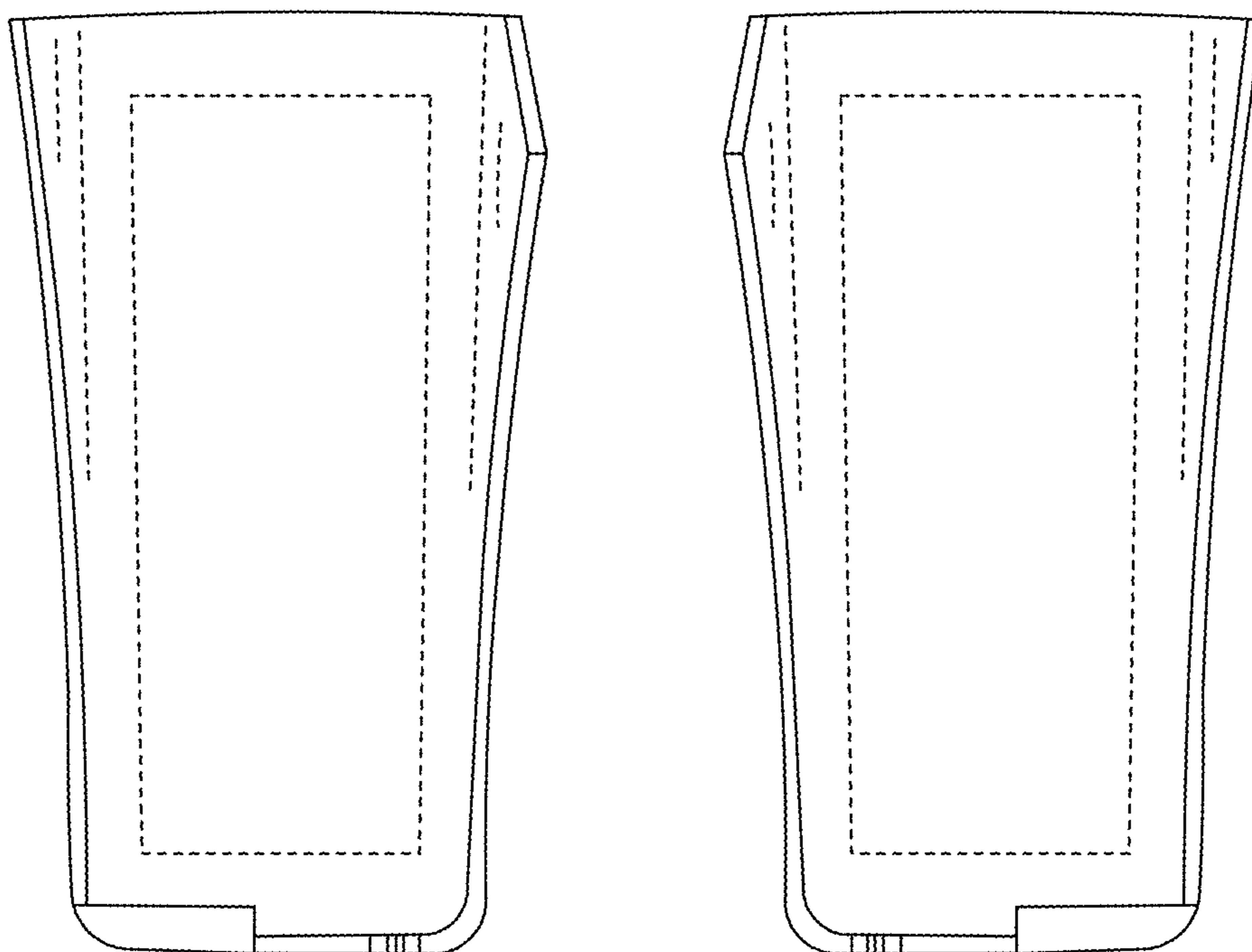

FIG. 8

