



US00D789256S

(12) **United States Design Patent**
Kutsch et al.

(10) **Patent No.:** **US D789,256 S**
(45) **Date of Patent:** **** Jun. 13, 2017**

(54) **WHEELED PERSONAL CONVEYANCE**

- (71) Applicant: **Medline Industries, Inc.**, Northfield, IL (US)
- (72) Inventors: **John Kutsch**, Harvard, IL (US); **Corbett Brown, Jr.**, Round Lake Park, IL (US); **Zhiliang Wang**, Zhongshan (CN)
- (73) Assignee: **Medline Industries, Inc.**, Northfield, IL (US)

(**) Term: **14 Years**

(21) Appl. No.: **29/513,376**

(22) Filed: **Dec. 30, 2014**

(51) **LOC (10) Cl.** **12-12**

(52) **U.S. Cl.**
USPC **D12/131**

(58) **Field of Classification Search**
USPC D12/128–133
CPC A61G 5/00–5/14
See application file for complete search history.

(56) **References Cited**

U.S. PATENT DOCUMENTS

2,685,325	A	8/1954	Wesley	
3,497,234	A	2/1970	Schray	
4,639,012	A	1/1987	Jensen	
5,558,358	A *	9/1996	Johnson	A61G 5/00 280/250.1
5,560,627	A *	10/1996	Zatulovsky	A61G 5/00 280/42
D427,949	S *	7/2000	Schlangen	D12/128
6,161,848	A	12/2000	Beumer	
6,315,306	B1	11/2001	Fernie	
6,412,795	B1	7/2002	Beumer	

(Continued)

FOREIGN PATENT DOCUMENTS

JP	2009017974	1/2009
WO	99012507	3/1999
WO	2013041201	3/2013

OTHER PUBLICATIONS

International Search Report and Written Opinion Dated Mar. 19, 2015 from PCT/ US2014/072711.

Primary Examiner — Charles Hanson

(74) *Attorney, Agent, or Firm* — Fitch, Even, Tabin & Flannery LLP

(57) **CLAIM**

We claim the ornamental design for a wheeled personal conveyance, as shown and described.

DESCRIPTION

FIG. 1 is a top perspective view showing a first embodiment of a wheeled personal conveyance in accordance with our new design;

FIG. 2 is a bottom perspective view thereof;

FIG. 3 is a front elevational view thereof;

FIG. 4 is a rear elevational view thereof;

FIG. 5 is a right side elevational view thereof;

FIG. 6 is a left side elevational view thereof;

FIG. 7 is a top plan view thereof;

FIG. 8 is a bottom plan view thereof;

FIG. 9 is a top perspective view showing a second embodiment of a wheeled personal conveyance in accordance with our new design;

FIG. 10 is a bottom perspective view thereof;

FIG. 11 is a front elevational view thereof;

FIG. 12 is a rear elevational view thereof;

FIG. 13 is a right side elevational view thereof;

FIG. 14 is a left side elevational view thereof;

FIG. 15 is a top plan view thereof; and,

FIG. 16 is a bottom plan view thereof.

The broken line showing is included for the purpose of illustrating unclaimed subject matter and forms no part of the claimed design.

1 Claim, 16 Drawing Sheets

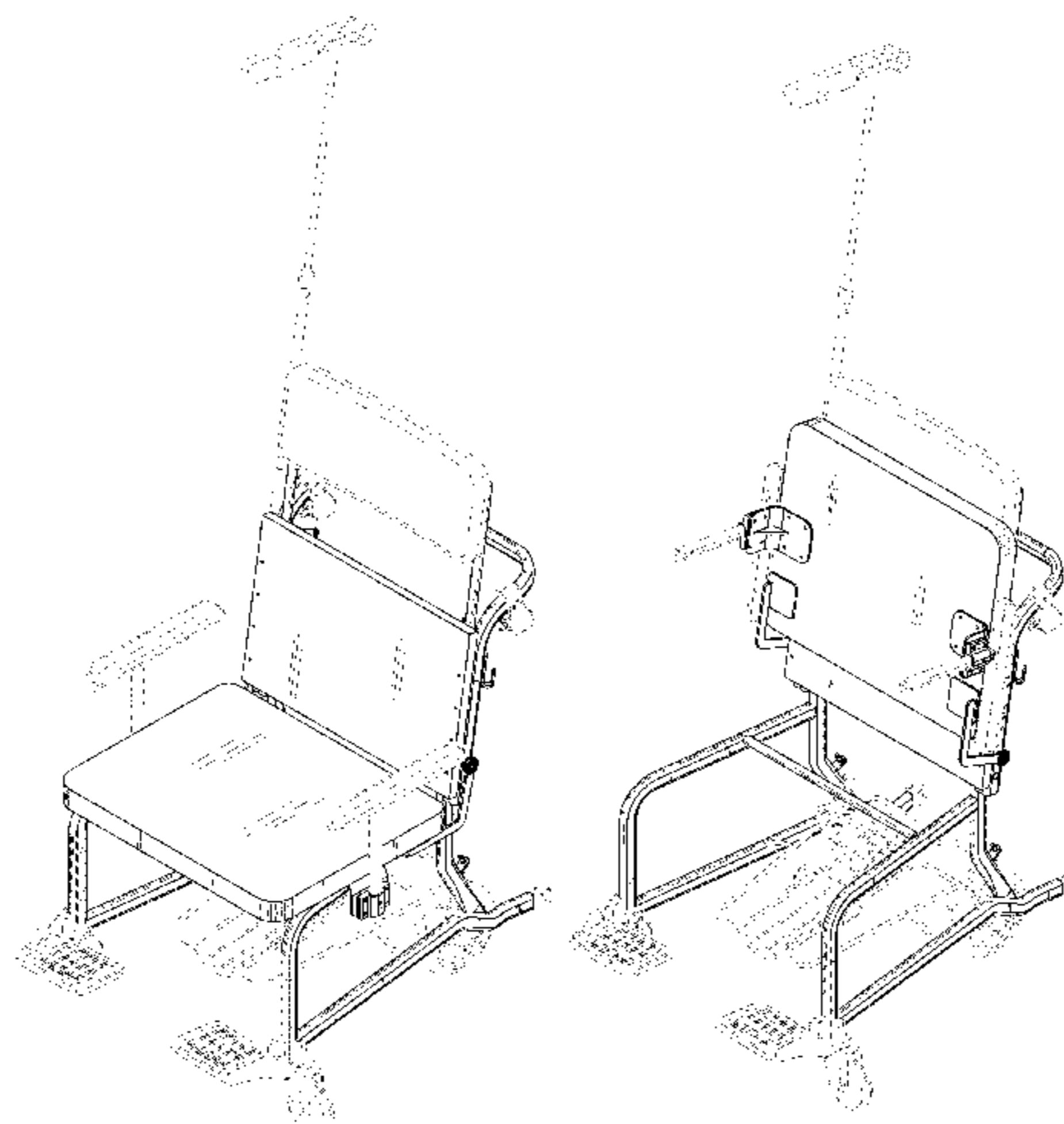

(56)

References Cited

U.S. PATENT DOCUMENTS

6,447,064	B1	9/2002	Mundy	
7,188,855	B1	3/2007	Thomas	
D618,141	S *	6/2010	Chan	D12/131
D622,641	S *	8/2010	Chen	D12/131
D623,992	S *	9/2010	Derks	D12/131
D624,459	S *	9/2010	Jacobs	D12/131
D633,830	S *	3/2011	Derks	D12/131
D635,895	S *	4/2011	Jacobs	D12/131
8,075,017	B2	12/2011	Ignacio	
D699,160	S *	2/2014	Yang	D12/131
8,985,618	B2	3/2015	Perk	
2002/0036422	A1	3/2002	Prince	
2003/0090073	A1	5/2003	Whang	
2004/0036258	A1	2/2004	Pleasant	
2007/0018426	A1 *	1/2007	Willis	A61G 5/08 280/304.1
2009/0033052	A1	2/2009	Bradshaw	
2012/0292879	A1	11/2012	Ferniany	
2013/0140782	A1	6/2013	Paul	
2013/0140783	A1	6/2013	Paul	

* cited by examiner

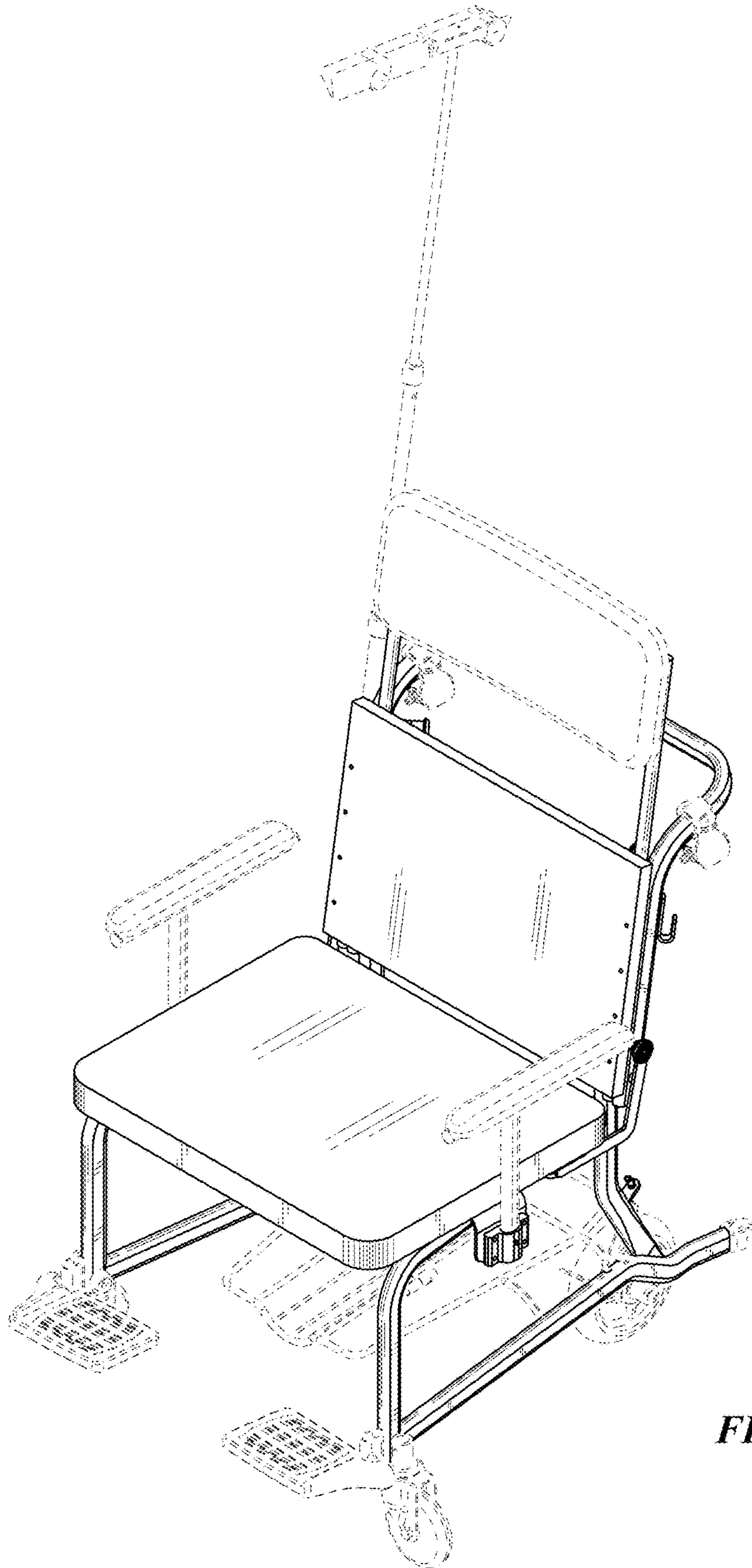

FIG. 1

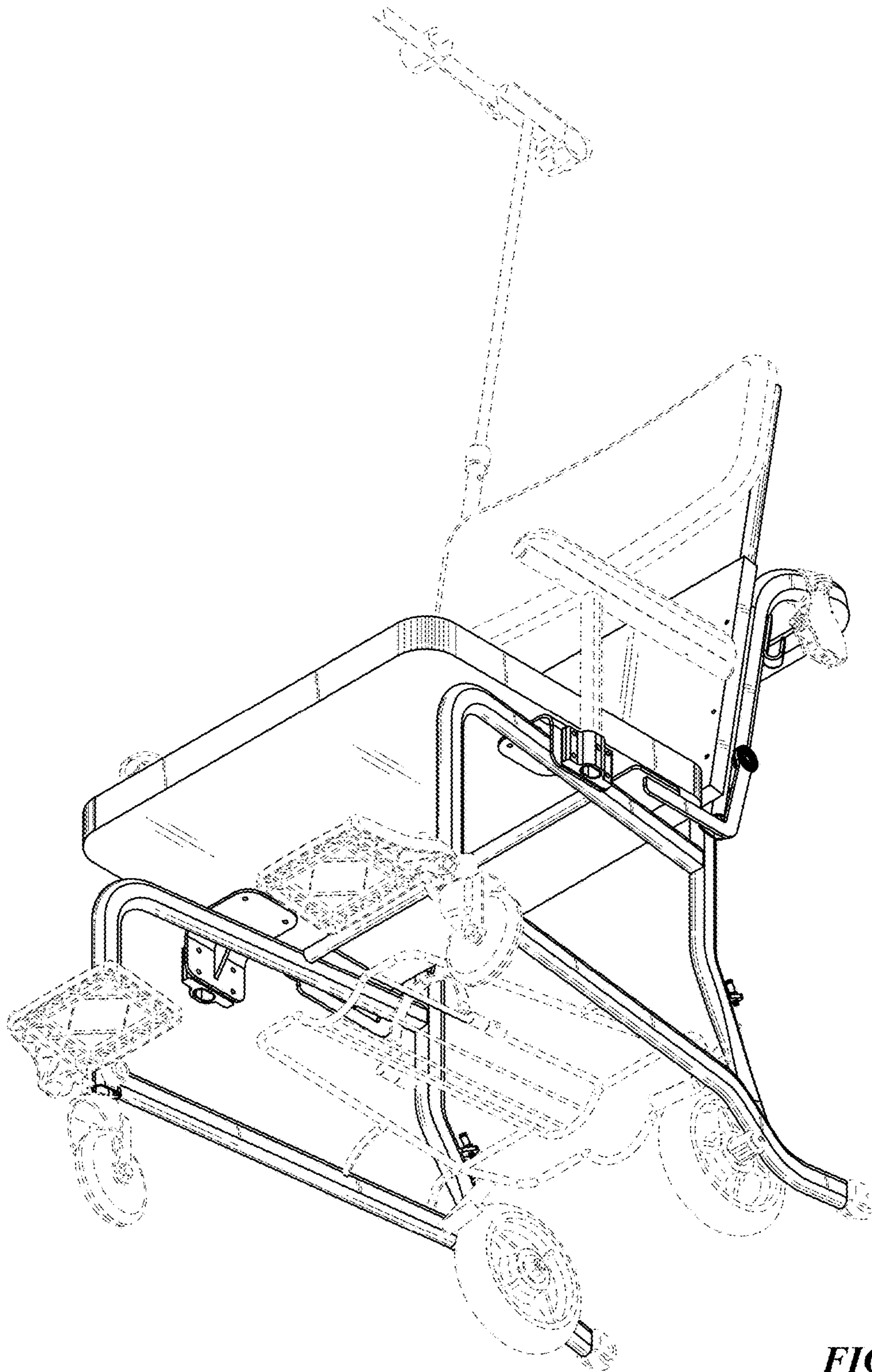

FIG. 2

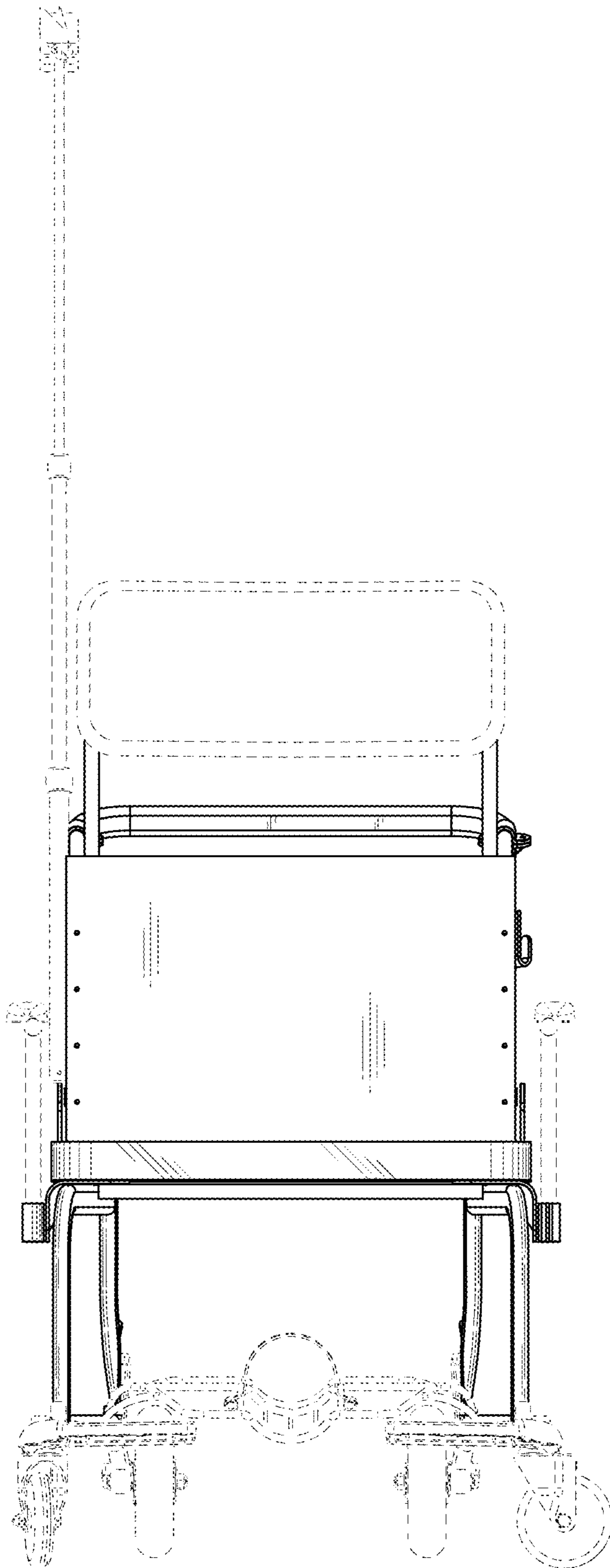

FIG. 3

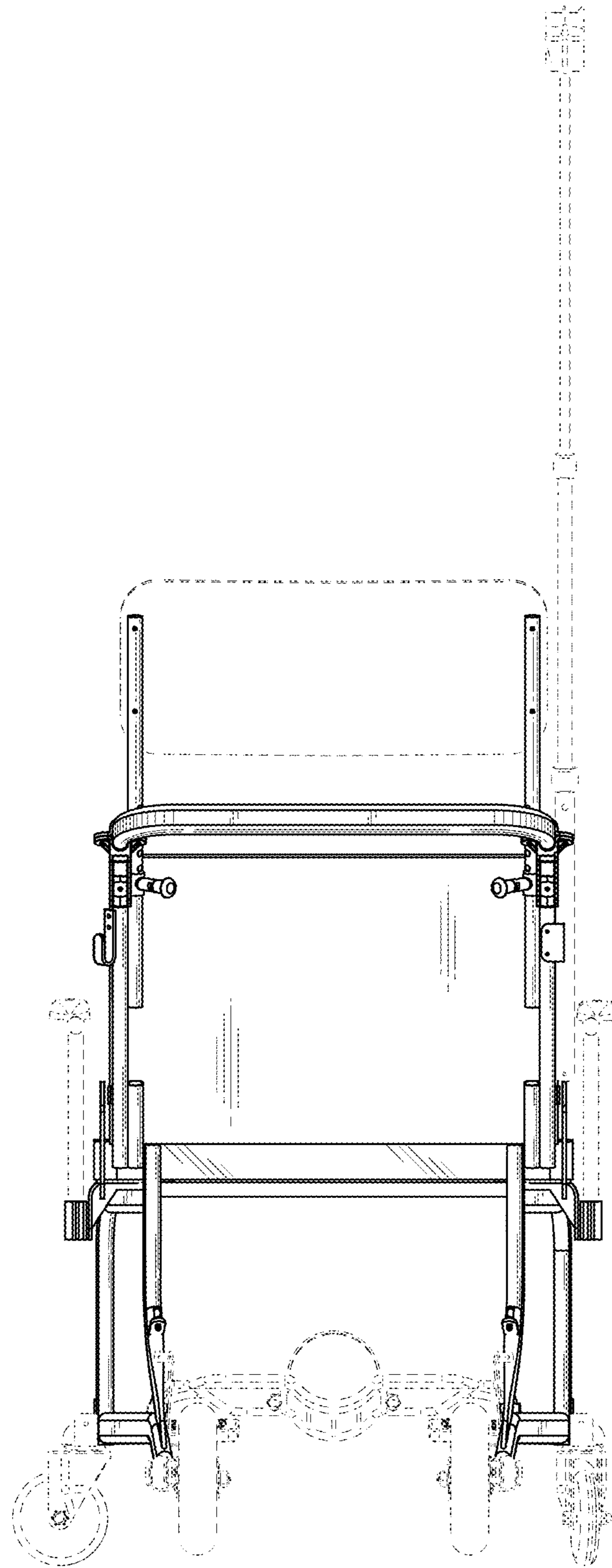

FIG. 4

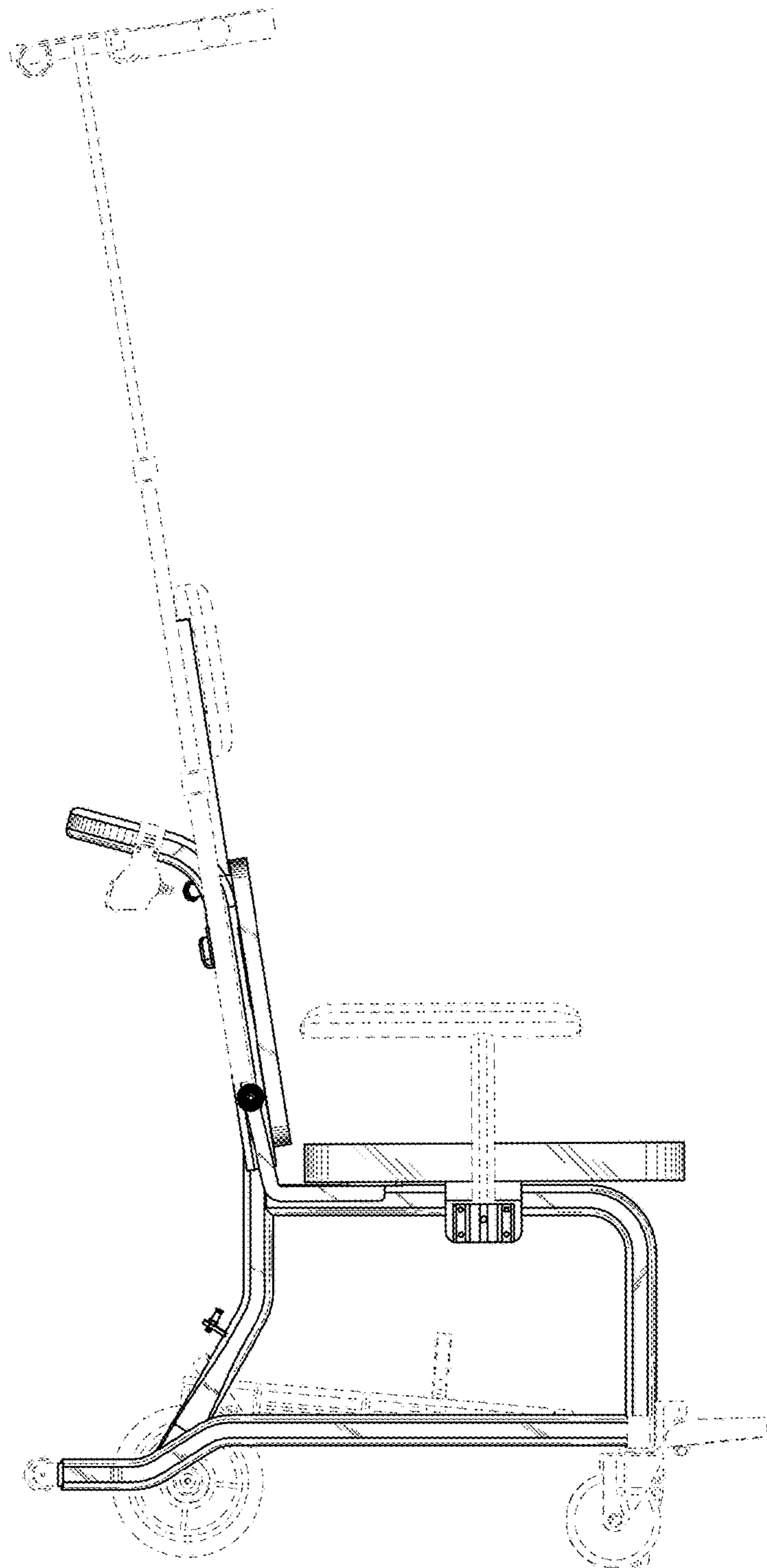

FIG. 5

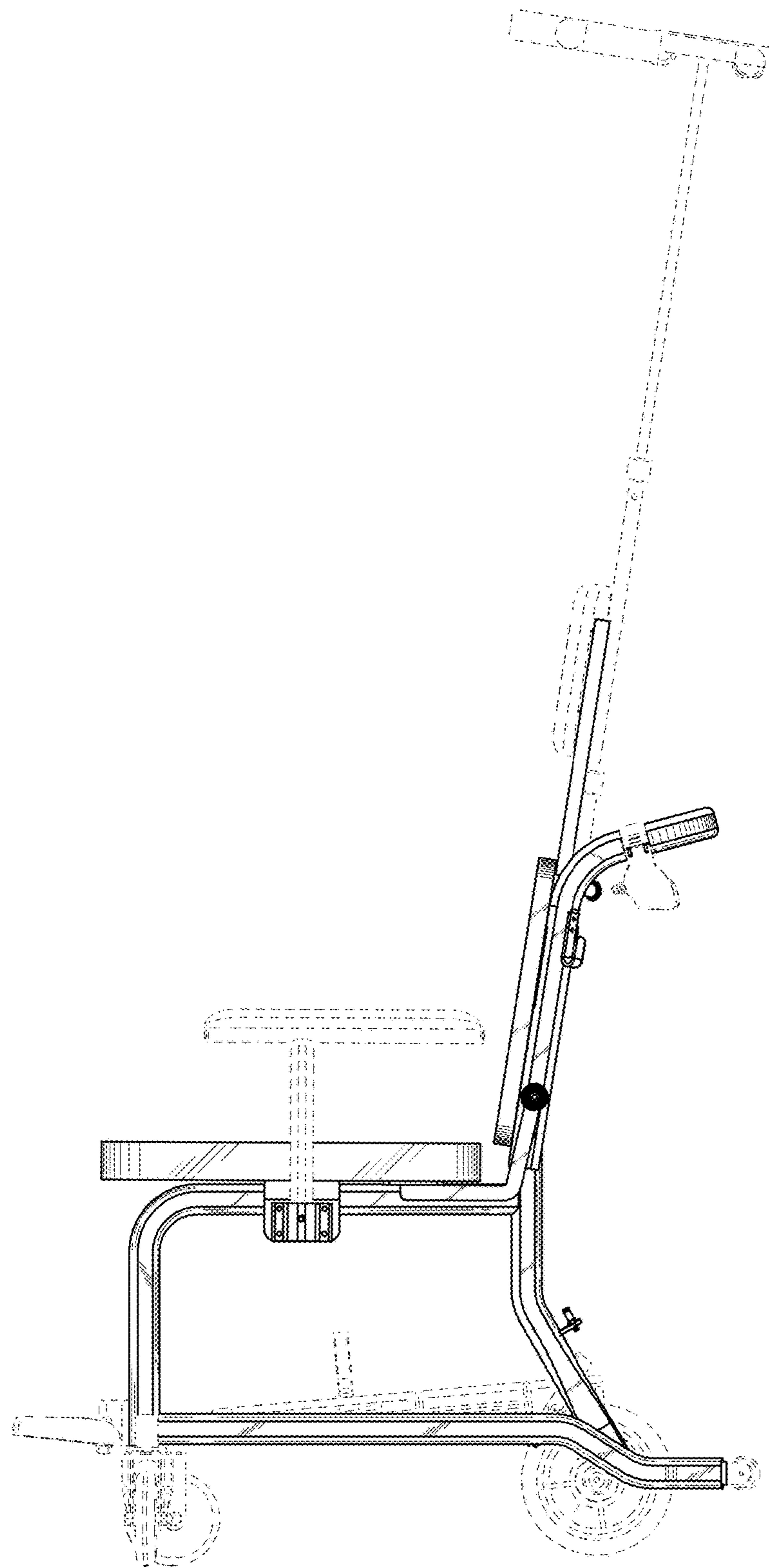

FIG. 6

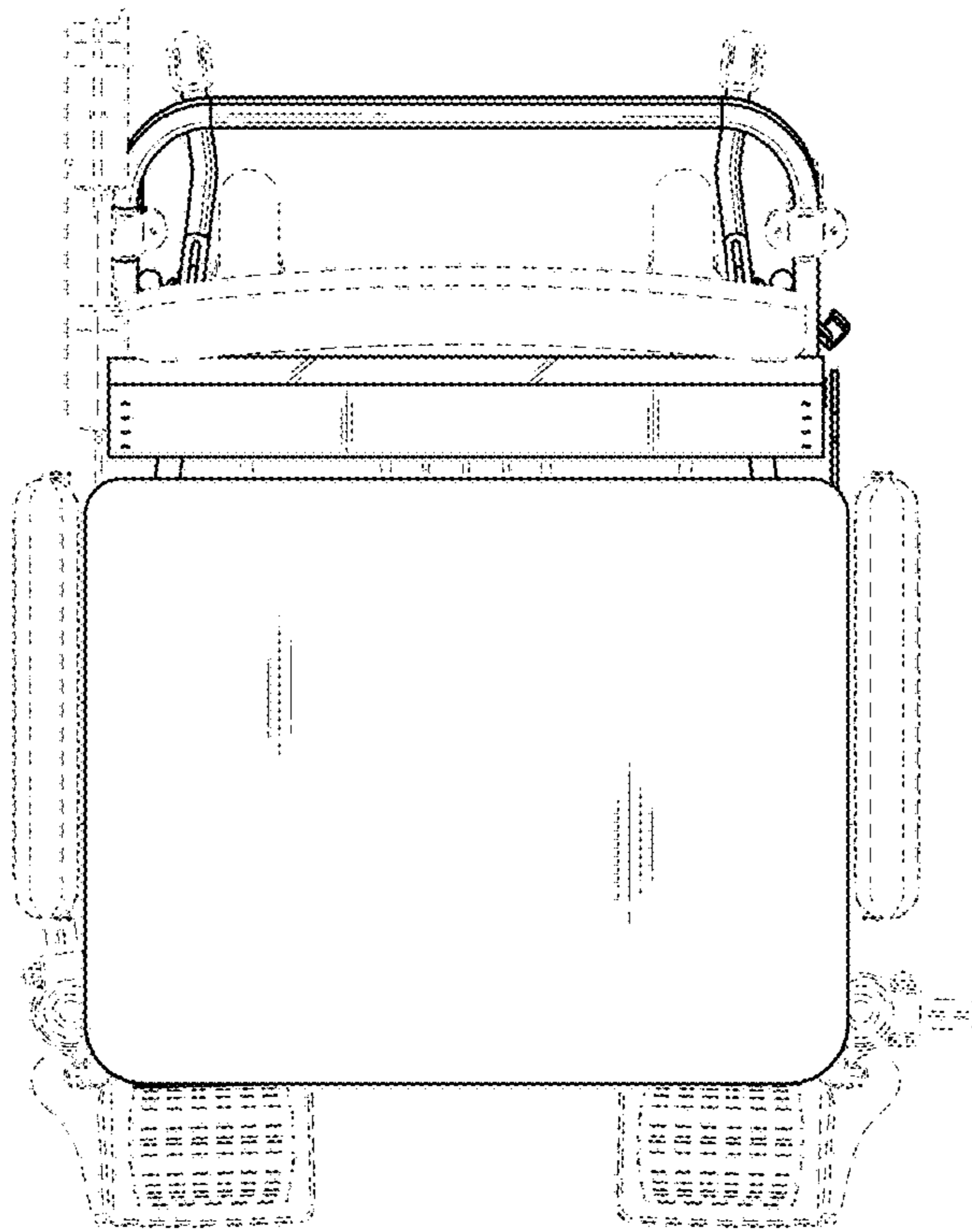

FIG. 7

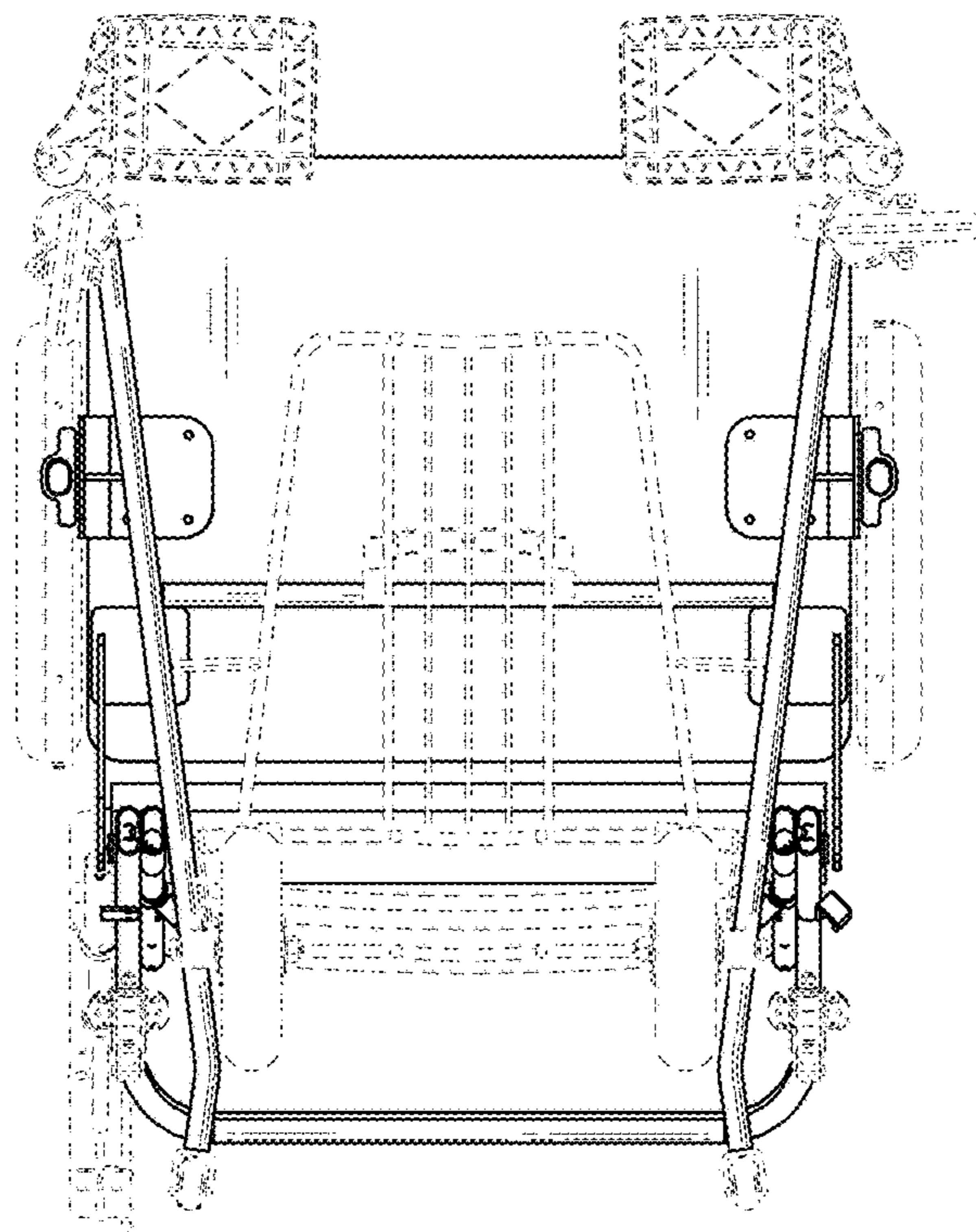

FIG. 8

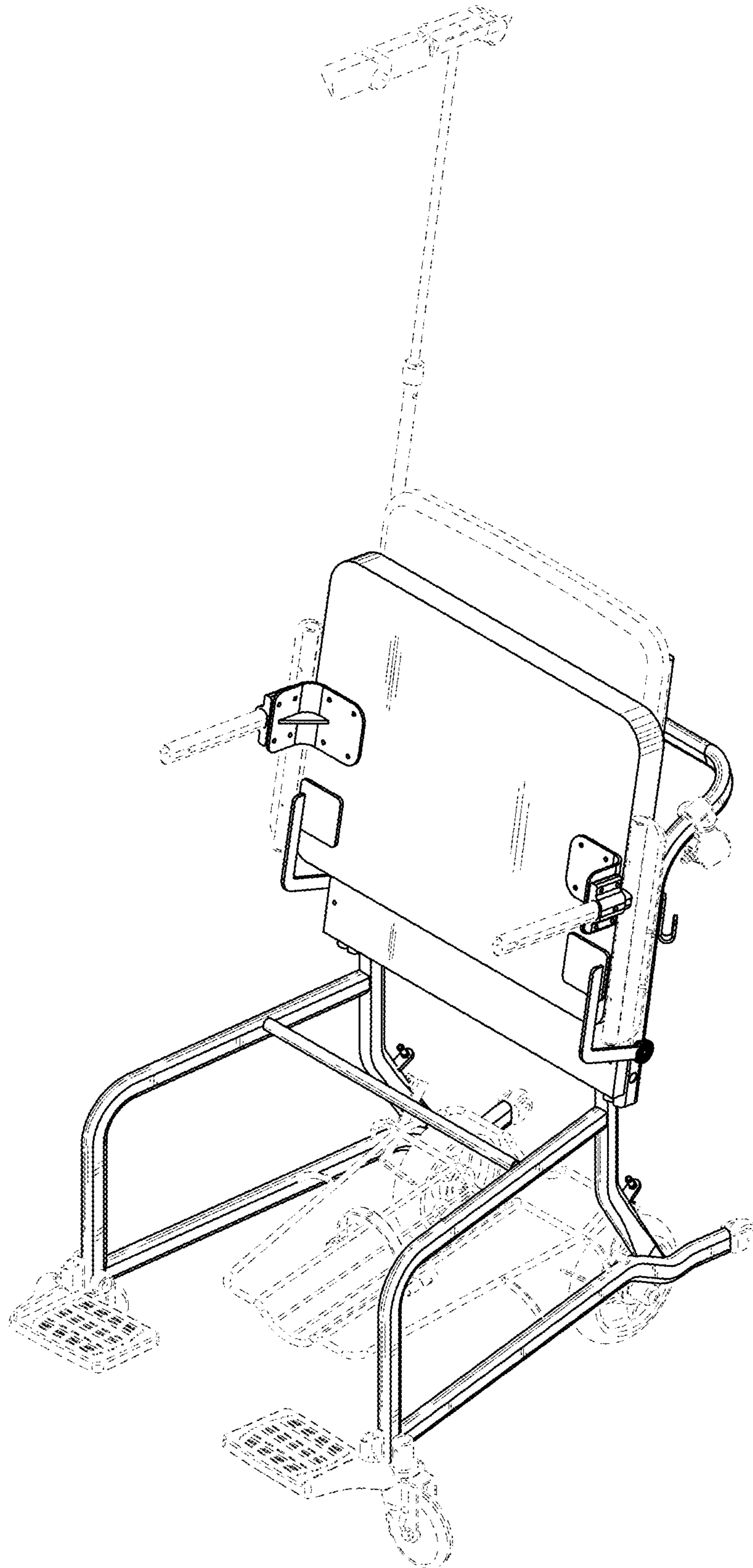

FIG. 9

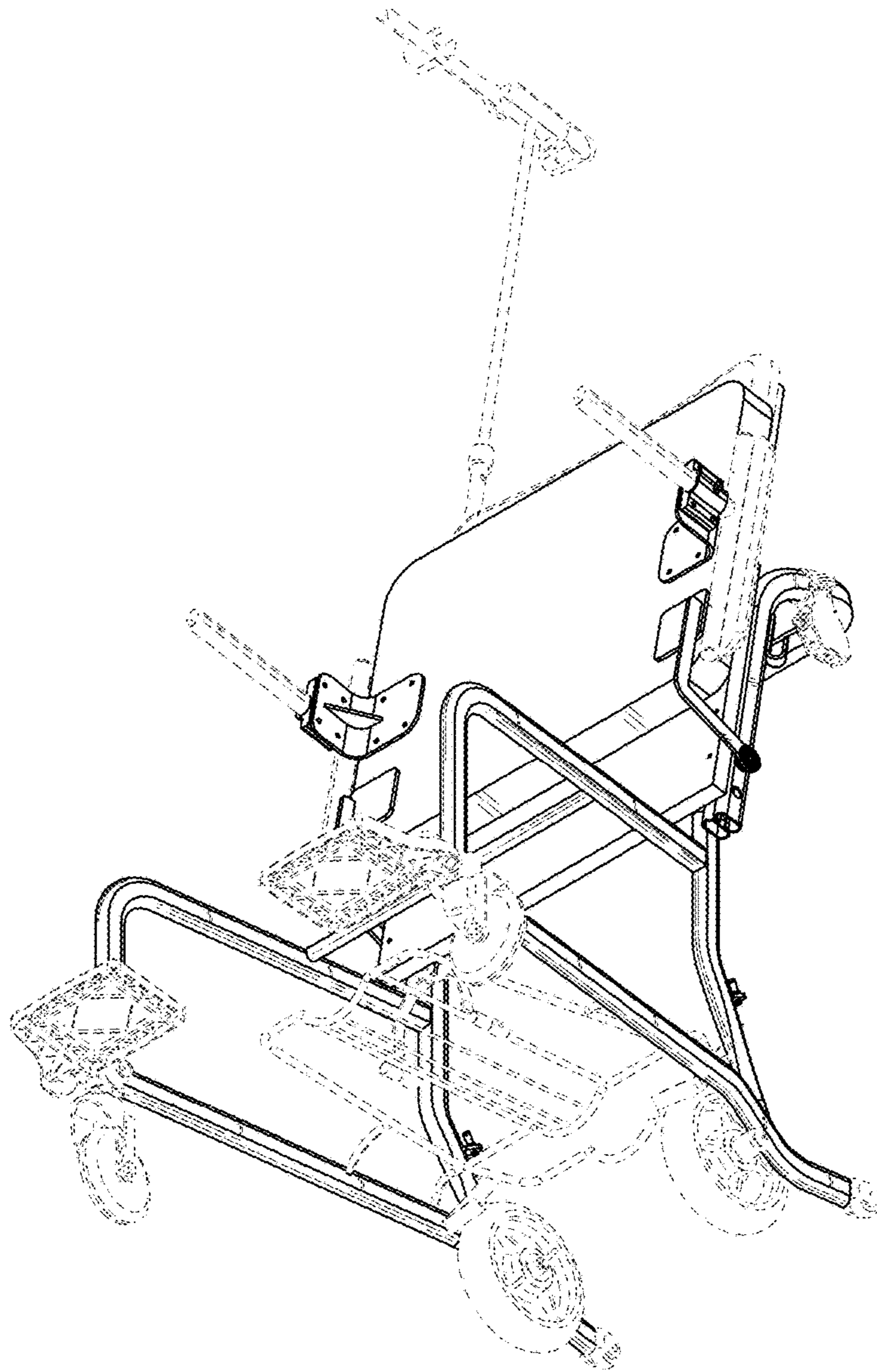

FIG. 10

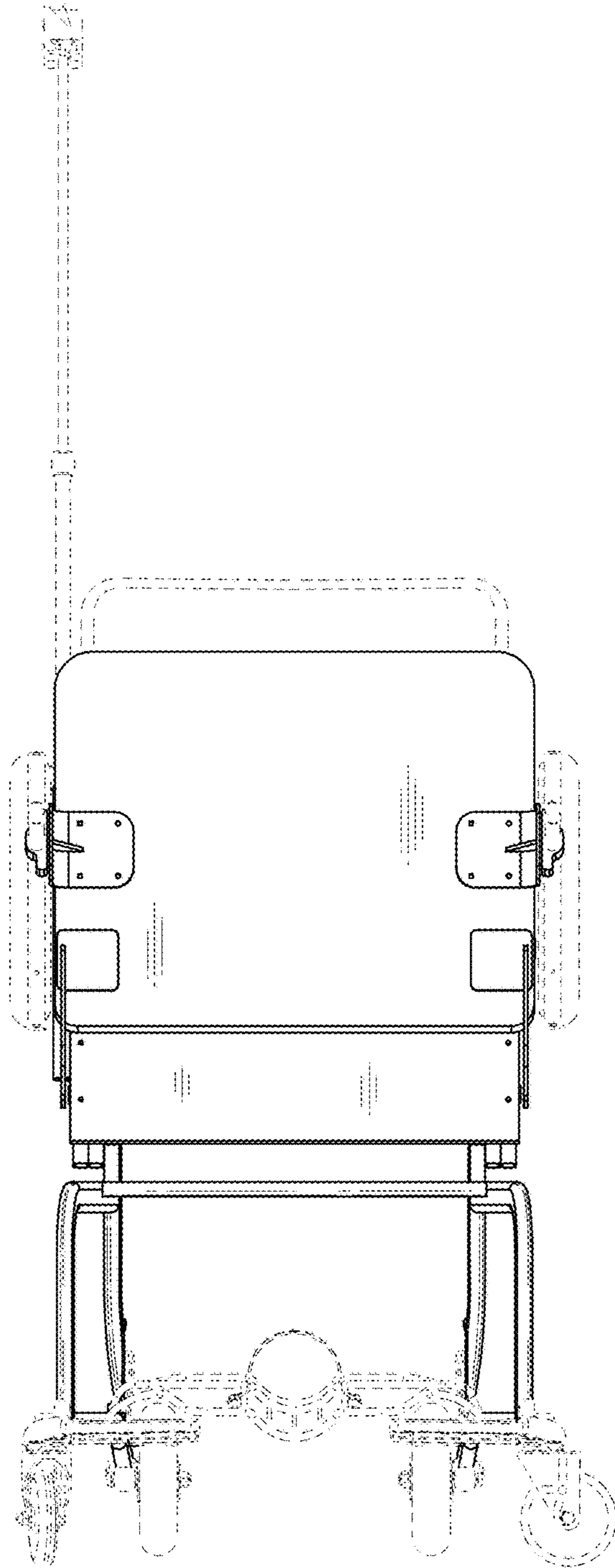

FIG. 11

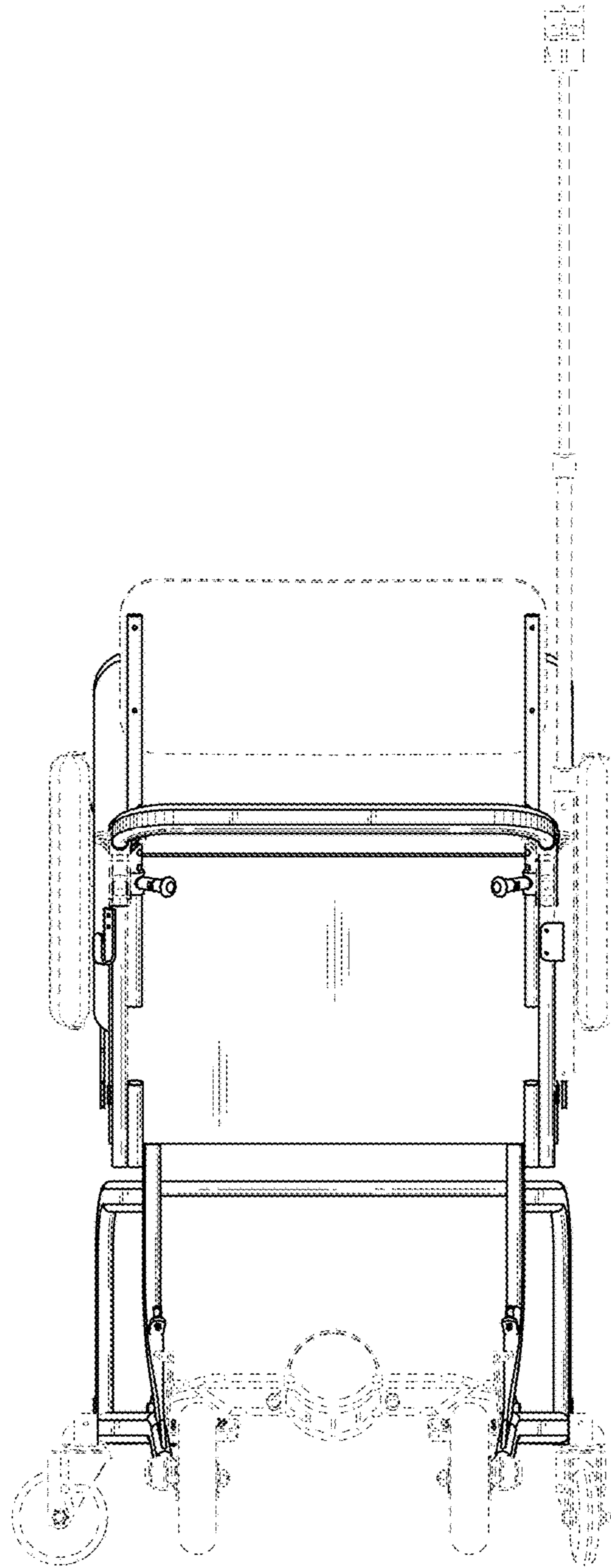

FIG. 12

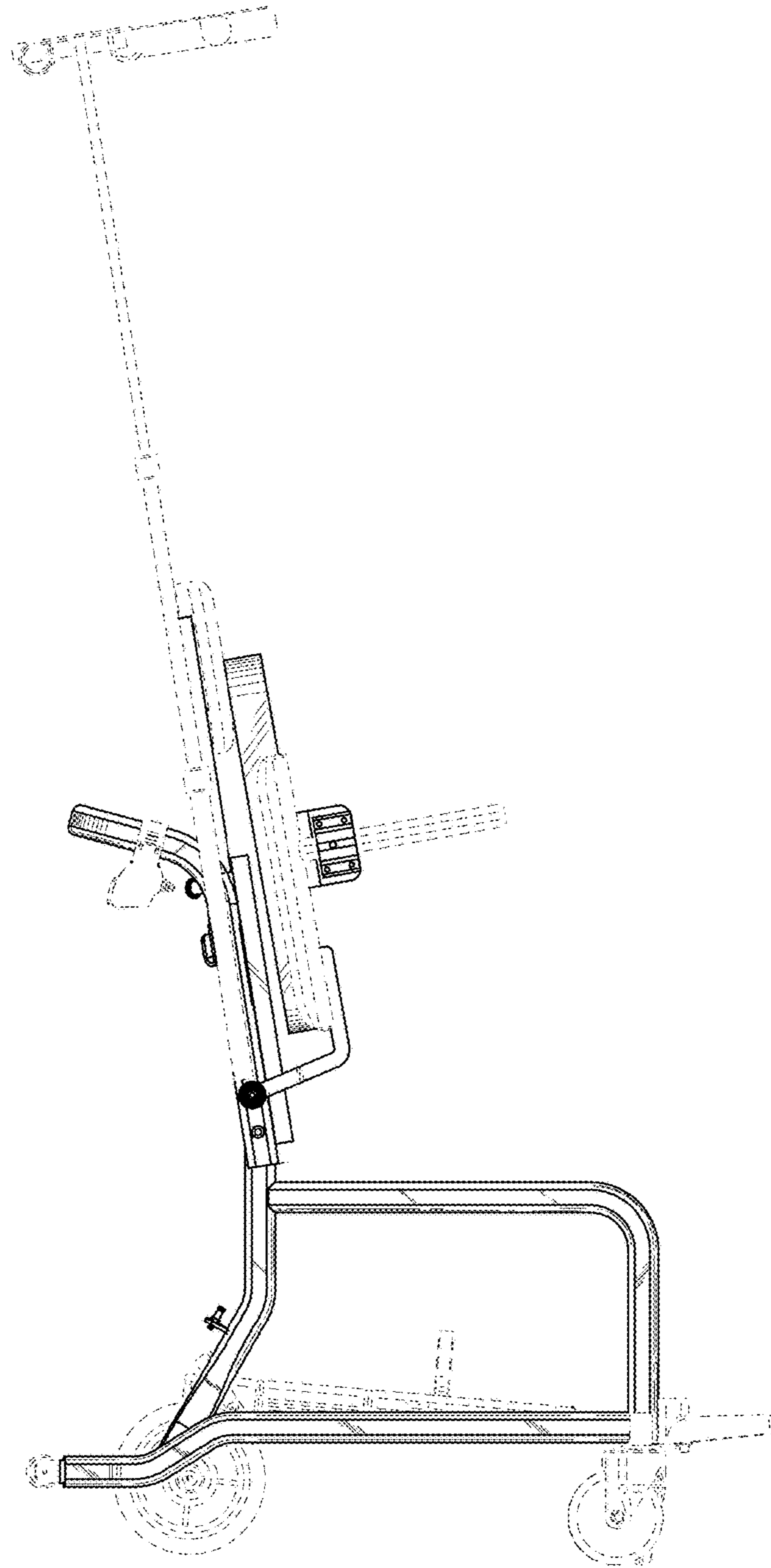

FIG. 13

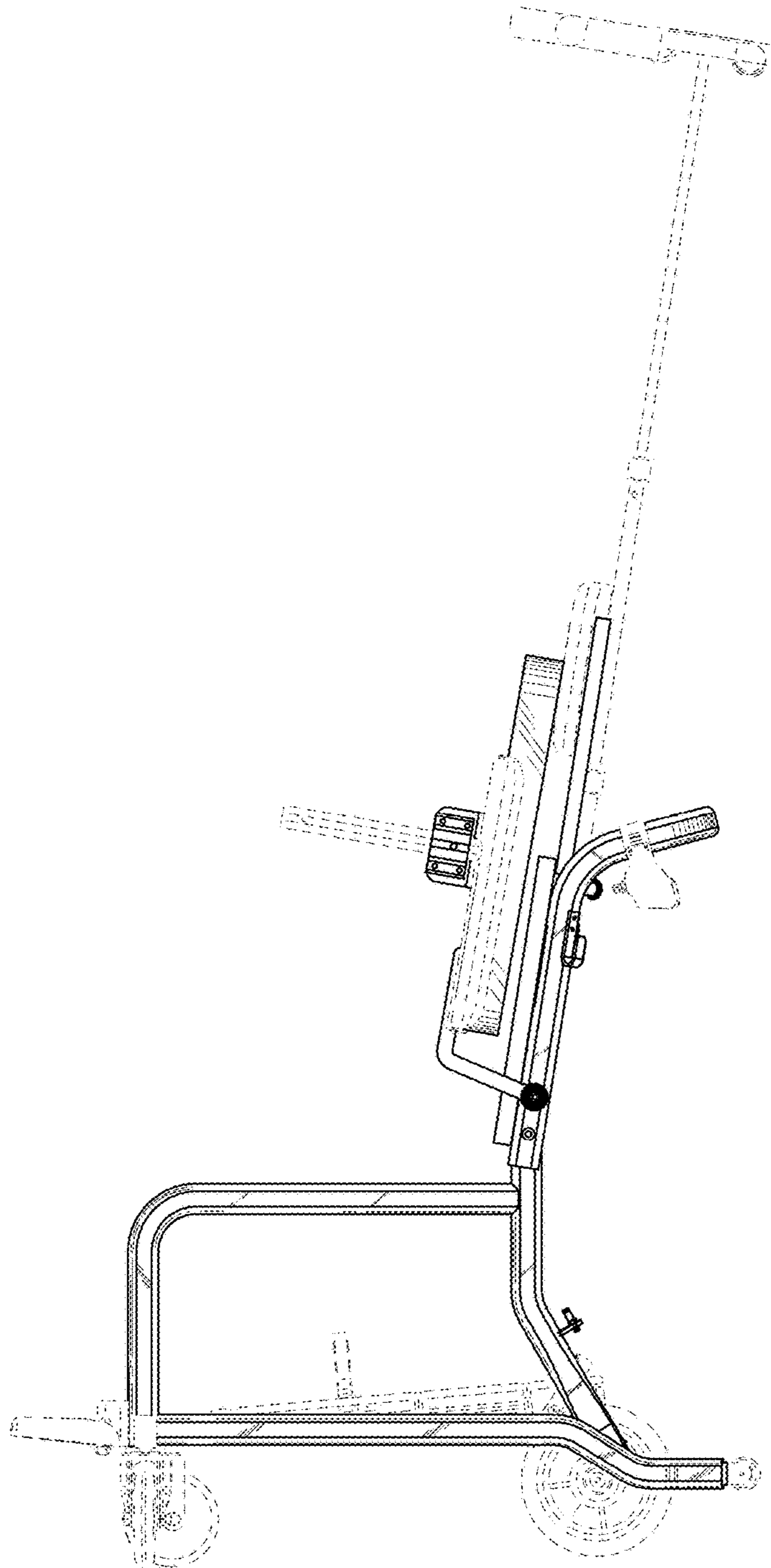

FIG. 14

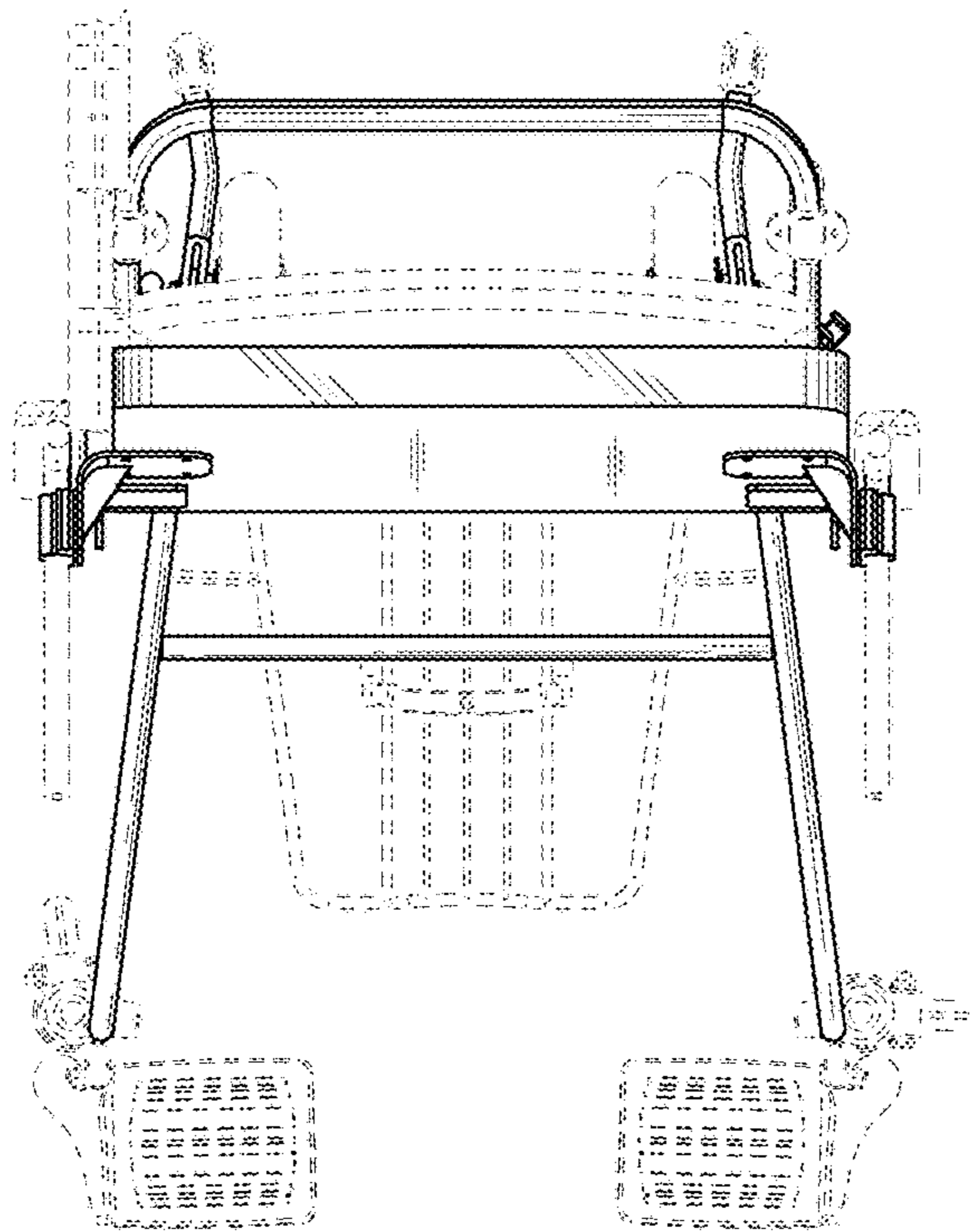

FIG. 15

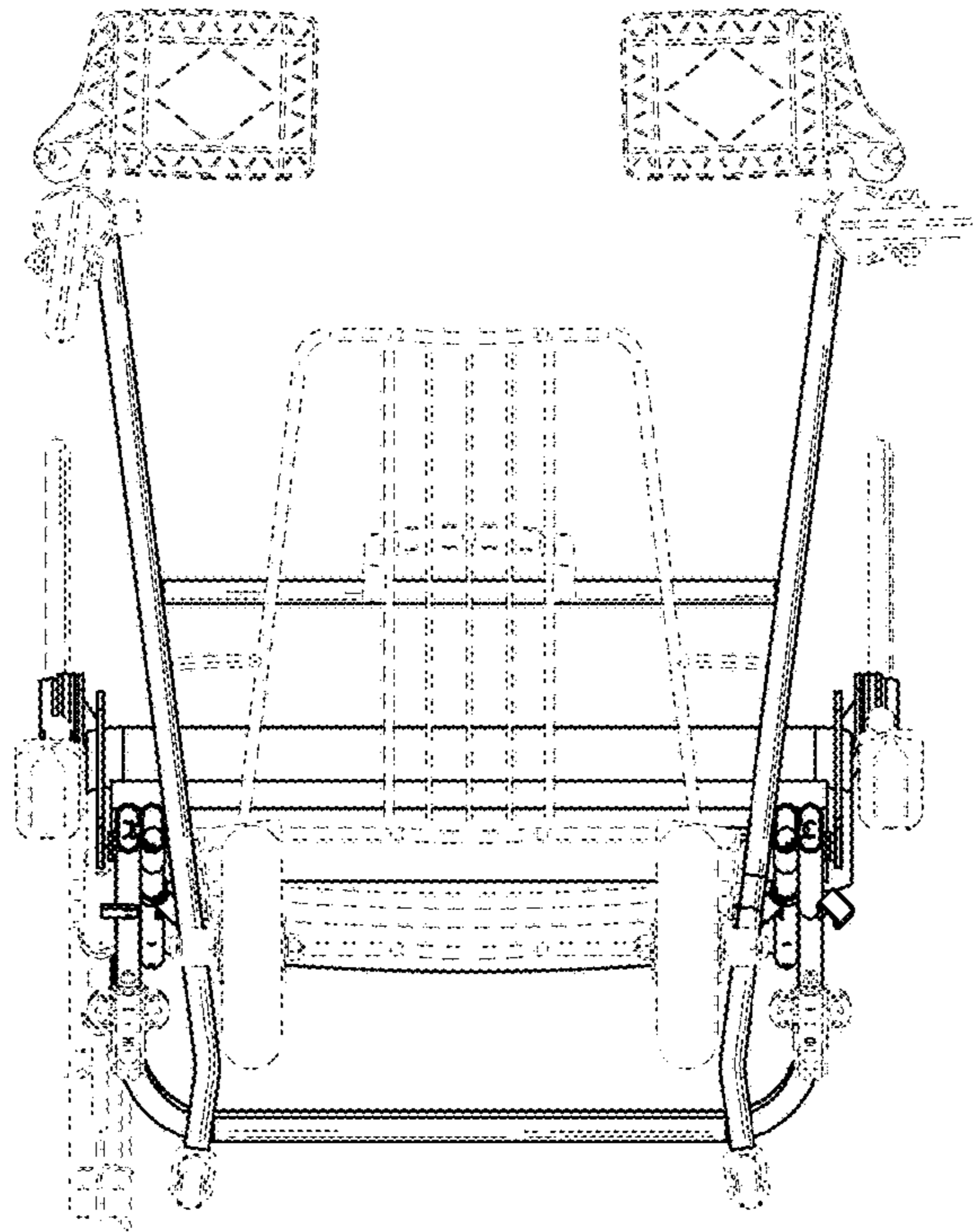

FIG. 16