



US00D788884S

(12) **United States Design Patent**
Ziemann et al.

(10) **Patent No.:** **US D788,884 S**
(45) **Date of Patent:** **** Jun. 6, 2017**

(54) **MIXING TAP**

(71) Applicant: **BLANCO GmbH + Co KG**,
Oberderdingen (DE)

(72) Inventors: **Brigitte Ziemann**, Eppingen (DE);
Oliver Kuch, Oberderdingen (DE)

(73) Assignee: **BLANCO GmbH + Co KG**,
Oberderdingen (DE)

(**) Term: **15 Years**

(21) Appl. No.: **29/544,419**

(22) Filed: **Nov. 3, 2015**

(30) **Foreign Application Priority Data**

Aug. 19, 2015 (CA) 163890

(51) **LOC (10) Cl.** **23-01**

(52) **U.S. Cl.**
USPC **D23/238**

(58) **Field of Classification Search**
USPC D23/238, 249-250, 252, 254;
D8/307-308, 310

(Continued)

(56) **References Cited**

U.S. PATENT DOCUMENTS

D532,866 S * 11/2006 Kirar D23/238
D577,418 S * 9/2008 Lammel D23/238

(Continued)

Primary Examiner — Robert Delehanty

(74) *Attorney, Agent, or Firm* — Hanley, Flight &
Zimmerman, LLC

(57) **CLAIM**

The ornamental design for a “mixing tap,” as shown and described.

DESCRIPTION

The patent or application file contains at least one drawing executed in color. Copies of this patent or patent application

publication with color drawing(s) will be provided by the Office upon request and payment of the necessary fee.

FIG. 1 is a perspective view of a mixing tap. The solid hatching indicates shading illustrating the three-dimensional shape of the mixing tap.

FIG. 2 is a front view of the mixing tap of FIG. 1. The solid hatching indicates shading illustrating the three-dimensional shape of the mixing tap.

FIG. 3 is a rear view of the mixing tap of FIG. 1. The solid hatching indicates shading illustrating the three-dimensional shape of the mixing tap.

FIG. 4 is a top plan view of the mixing tap of FIG. 1. The solid hatching indicates shading illustrating the three-dimensional shape of the mixing tap.

FIG. 5 is a bottom view of the mixing tap of FIG. 1. The solid hatching indicates shading illustrating the three-dimensional shape of the mixing tap.

FIG. 6 is a left side view of the mixing tap of FIG. 1. The solid hatching indicates shading illustrating the three-dimensional shape of the mixing tap.

FIG. 7 is a right side view of the mixing tap of FIG. 1. The solid hatching indicates shading illustrating the three-dimensional shape of the mixing tap.

FIG. 8 is a perspective view of a mixing tap. The solid hatching indicates shading illustrating the three-dimensional configuration of the mixing tap. The dashed upward diagonal hatching represents a first color. The dashed downward diagonal hatching represents a second color.

FIG. 9 is a front view of the mixing tap of FIG. 8. The solid hatching indicates shading illustrating the three-dimensional configuration of the mixing tap. The dashed upward diagonal hatching represents a first color. The dashed downward diagonal hatching represents a second color.

FIG. 10 is a rear view of the mixing tap of FIG. 8. The solid hatching indicates shading illustrating the three-dimensional configuration of the mixing tap. The dashed upward diagonal hatching represents a first color. The dashed downward diagonal hatching represents a second color.

FIG. 11 is a top plan view of the mixing tap of FIG. 8. The solid hatching indicates shading illustrating the three-dimensional configuration of the mixing tap. The dashed upward diagonal hatching represents a first color. The dashed downward diagonal hatching represents a second color.

(Continued)

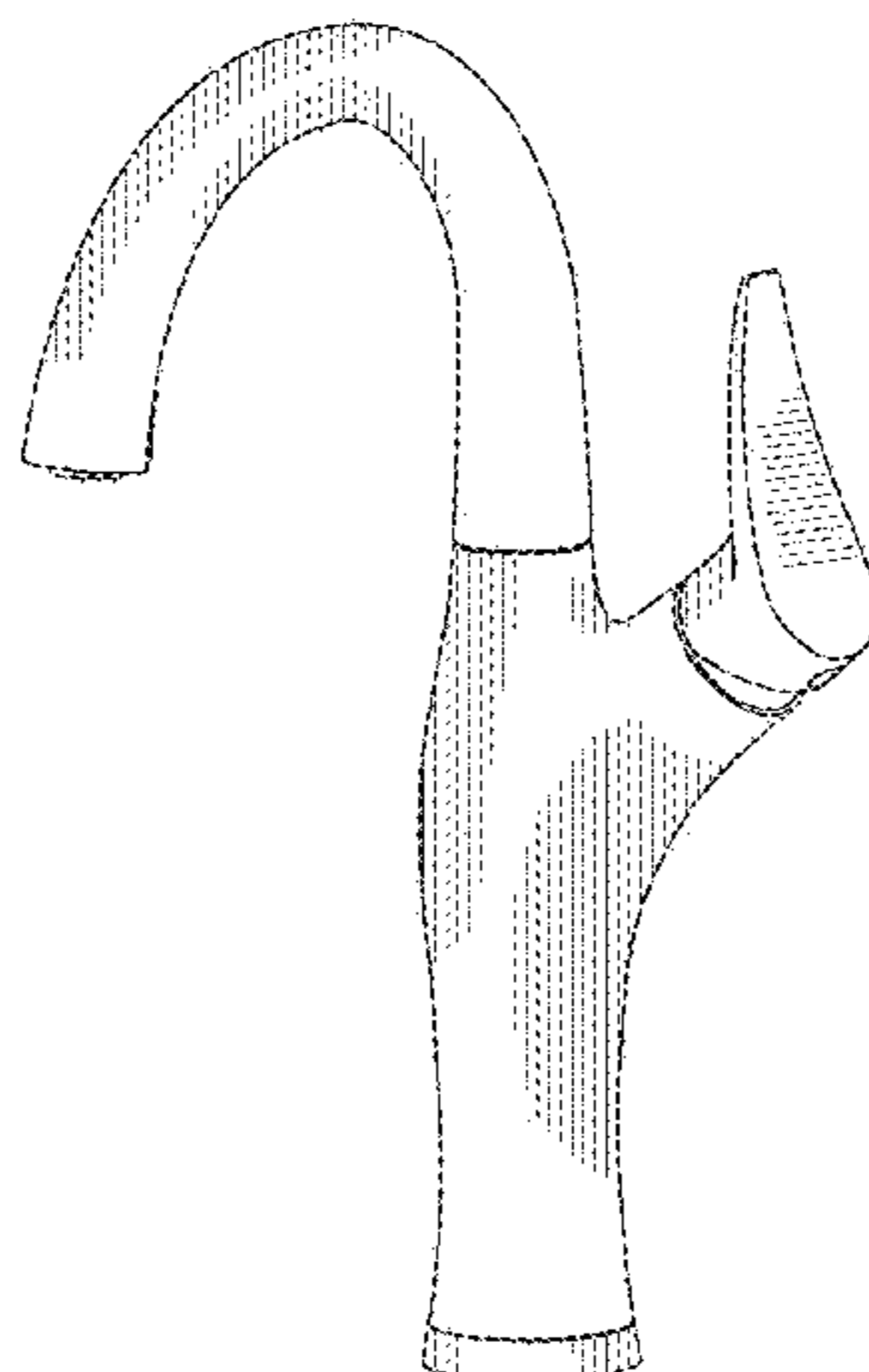

FIG. 12 is a bottom view of the mixing tap of FIG. 8. The solid hatching indicates shading illustrating the three-dimensional configuration of the mixing tap. The dashed upward diagonal hatching represents a first color. The dashed downward diagonal hatching represents a second color.

FIG. 13 is a left side view of the mixing tap of FIG. 8. The solid hatching indicates shading illustrating the three-dimensional configuration of the mixing tap. The dashed upward diagonal hatching represents a first color. The dashed downward diagonal hatching represents a second color; and,

FIG. 14 is a right side view of the mixing tap of FIG. 8. The solid hatching indicates shading illustrating the three-dimensional configuration of the mixing tap. The dashed upward diagonal hatching represents a first color. The dashed downward diagonal hatching represents a second color.

The features shown in broken lines form no part of the claimed design. While FIGS. 1 through 14 include solid lines, it is the Applicant's intention to disclose all of the features of FIGS. 1 through 14 as part of the specification and to reserve the right to claim any or all of those features in any combination in this or in a continuation application or a divisional application by converting any one or more solid lines of FIGS. 1 through 14 into broken lines in order to claim any aspect(s) of this disclosed design in isolation or in any combination. The Applicant's disclosure is, thus, not limited to the initial claim reflected in FIG. 1 through 14 but encompasses every aspect of FIGS. 1 through 14 alone and/or in combination.

The drawing is lined for color.

In FIGS. 8 through 14, the first color is different from the second color. Preferably, the first color is darker than the second color.

**1 Claim, 14 Drawing Sheets
(14 of 14 Drawing Sheet(s) Filed in Color)**

(58) **Field of Classification Search**

CPC . E03C 1/00; E03C 1/0404; E03C 1/02; E03C 1/021; E03C 1/057; E03C 2001/0411; E03C 2001/0415; E03C 2001/0417; Y10T 137/9464; B05B 15/065; A47L 17/00

See application file for complete search history.

(56) **References Cited**

U.S. PATENT DOCUMENTS

D622,361	S *	8/2010	Lammel	D23/255
D697,588	S *	1/2014	Schoenherr	D23/238
9,032,565	B2 *	5/2015	Loeck	E03C 1/057 251/129.04
9,057,184	B2 *	6/2015	Meehan	E03C 1/057
D757,902	S *	5/2016	Schoenherr	D23/238

* cited by examiner

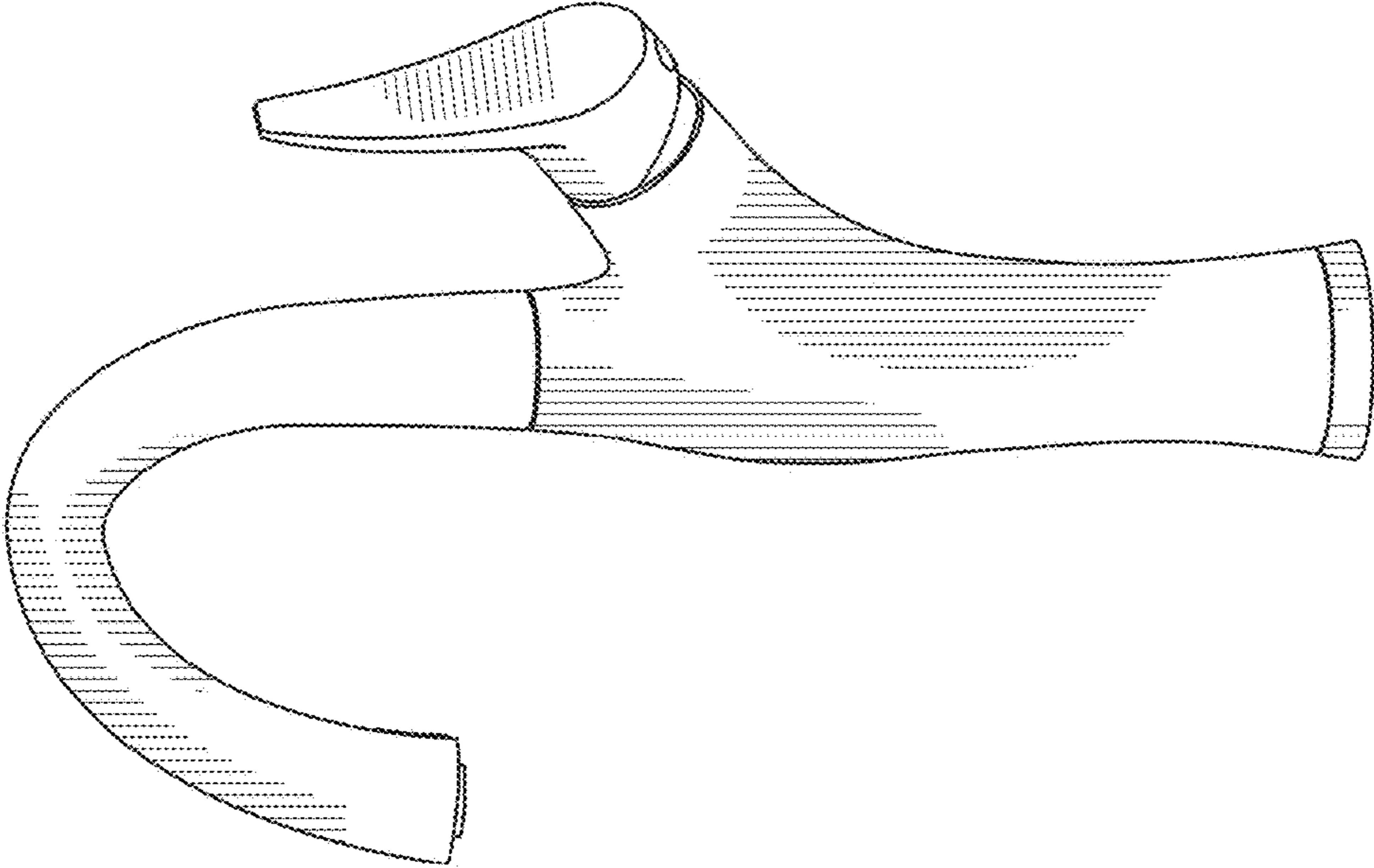

FIG. 1

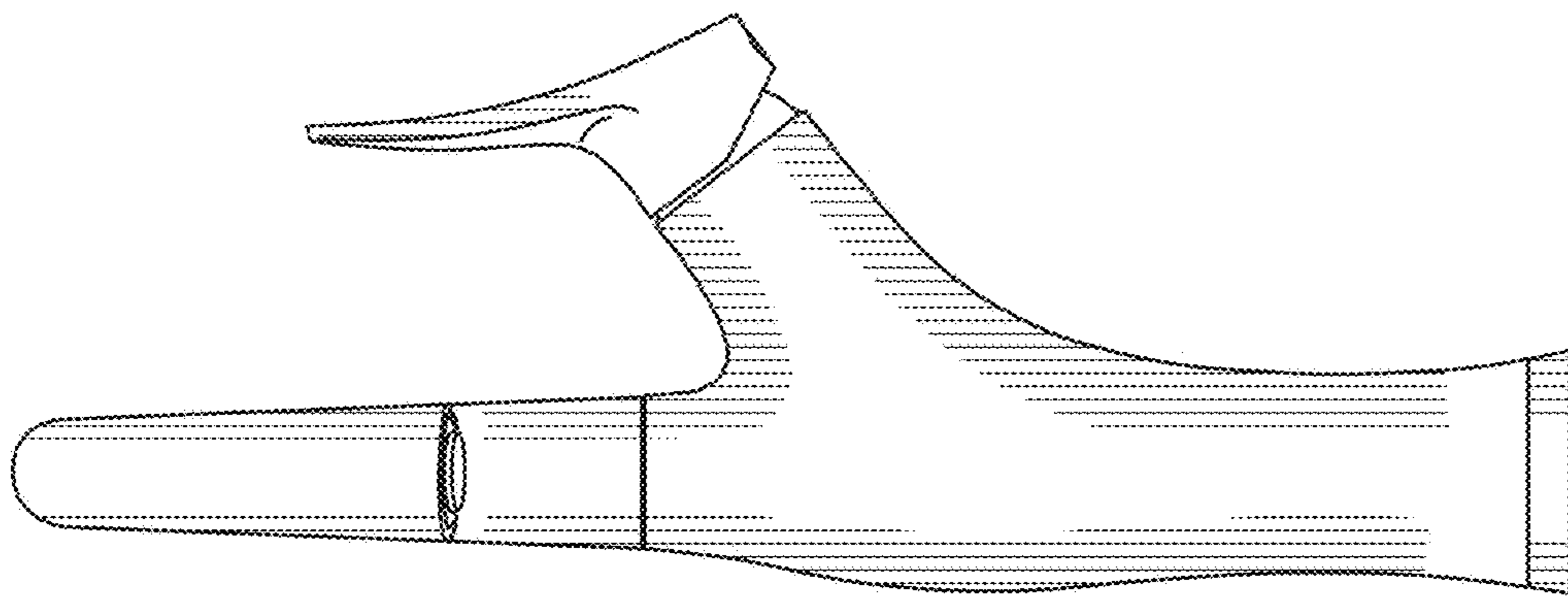

FIG. 2

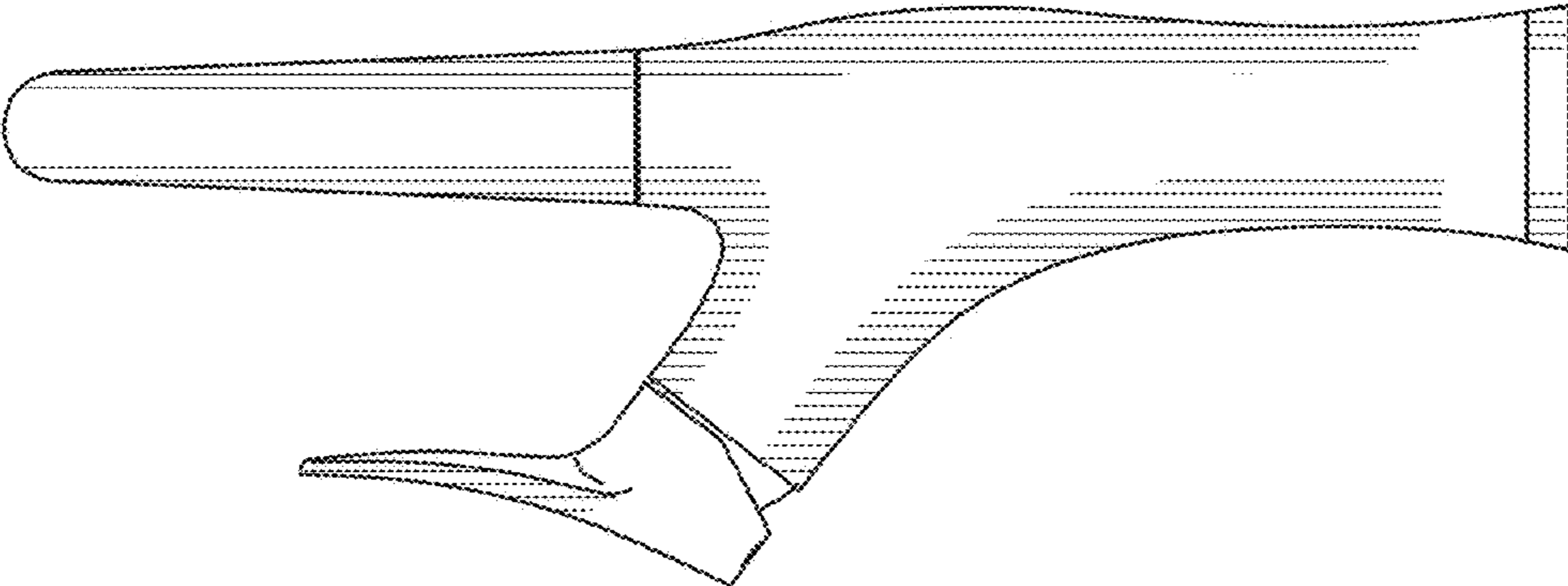

FIG. 3

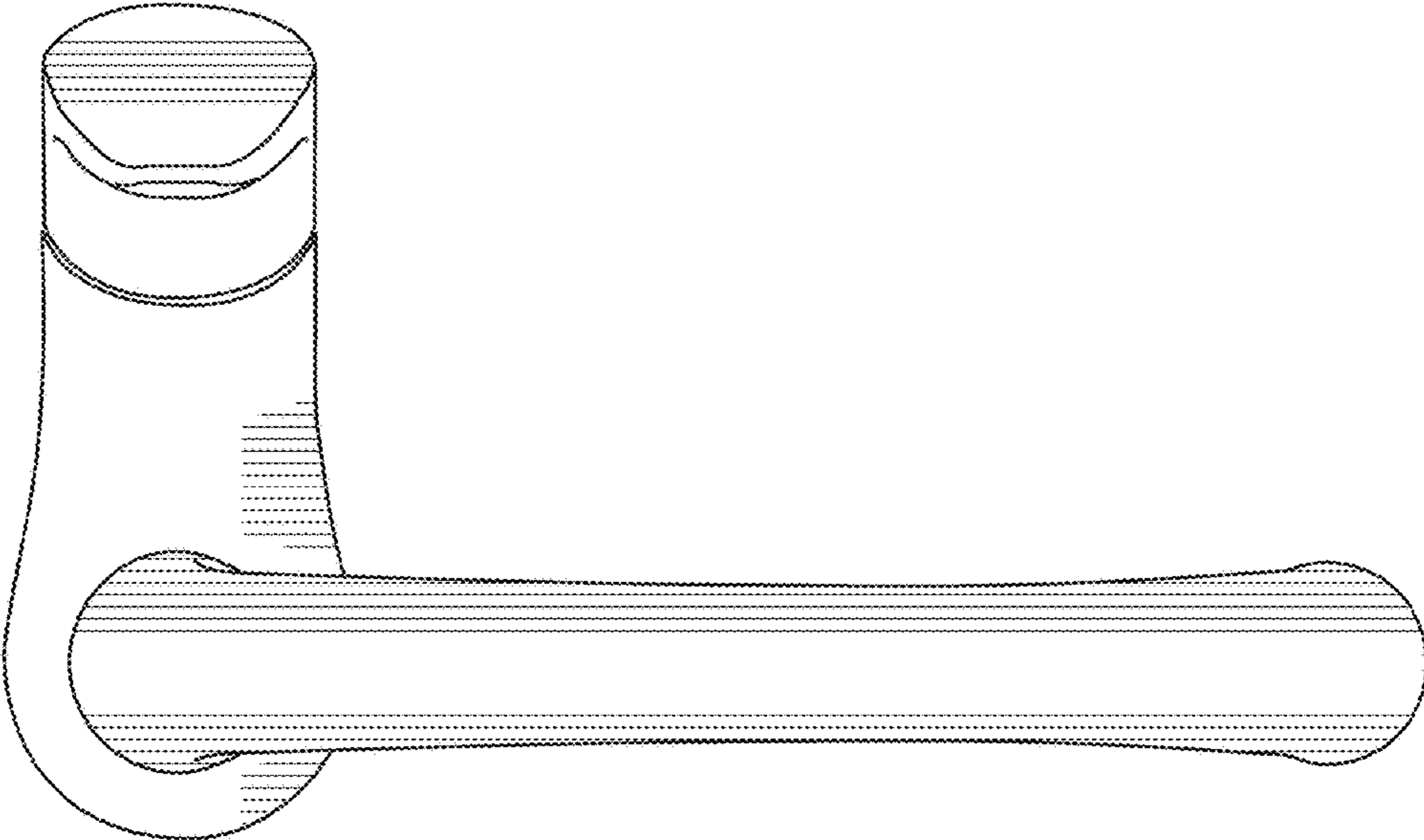

FIG. 4

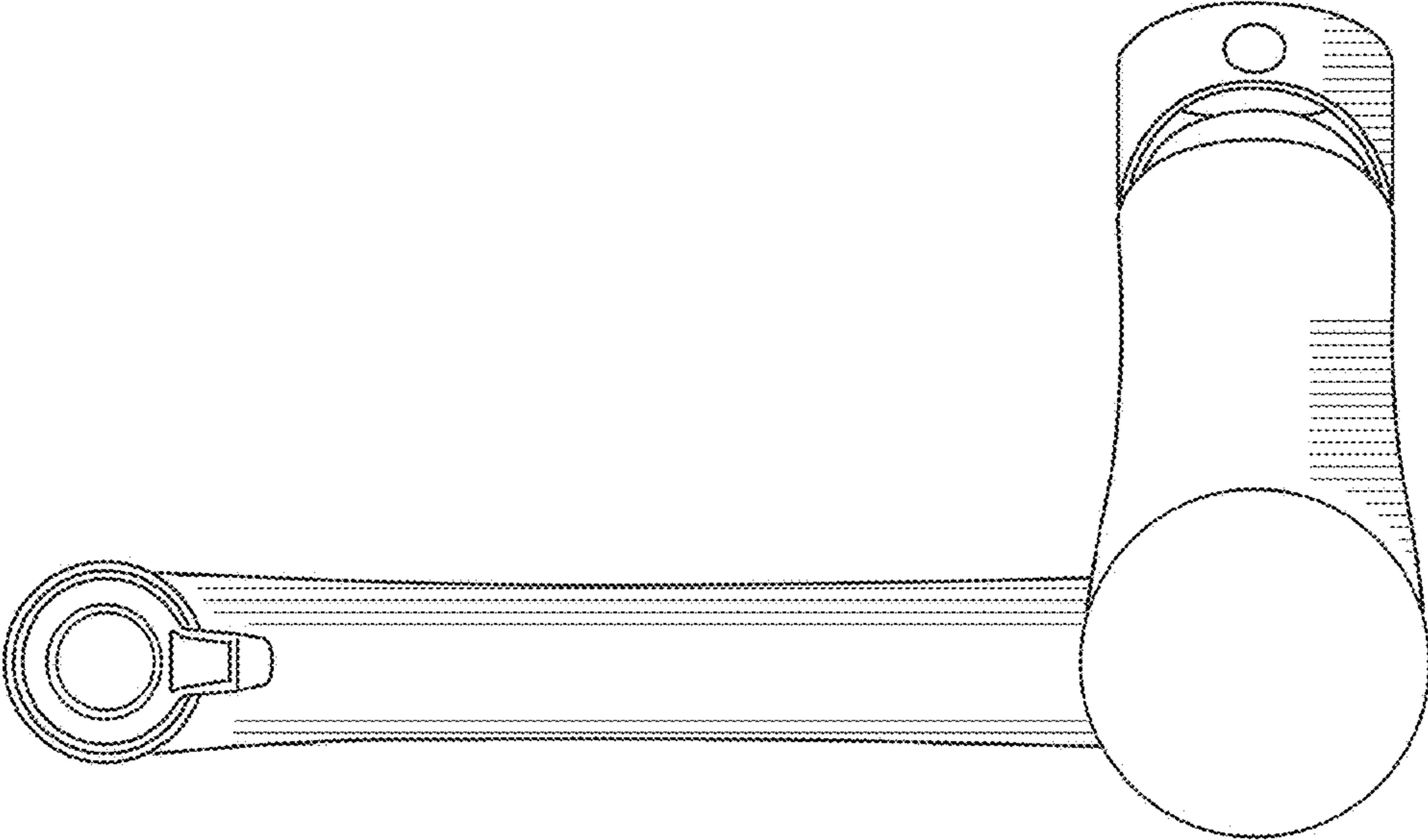

FIG. 5

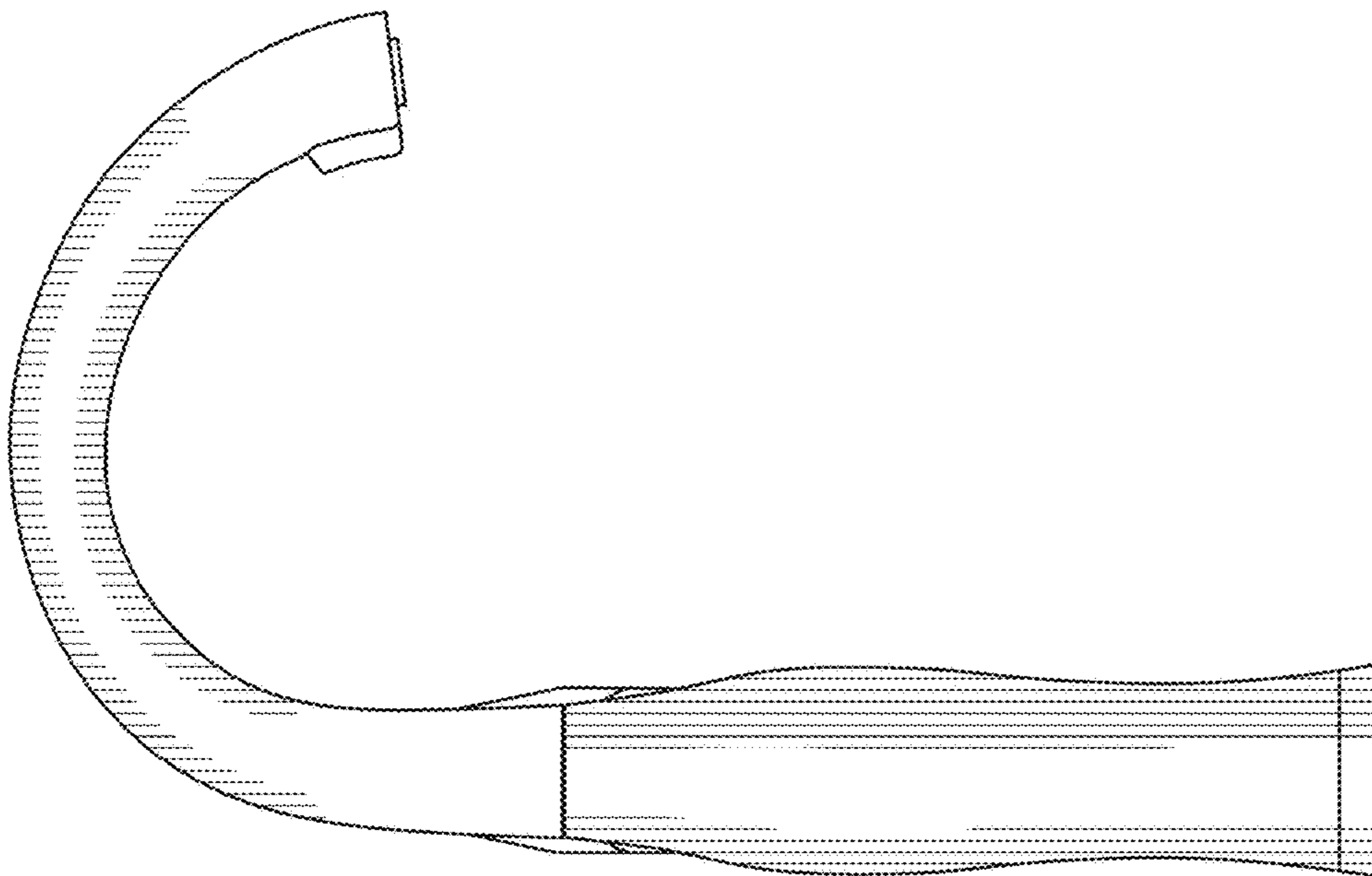

FIG. 6

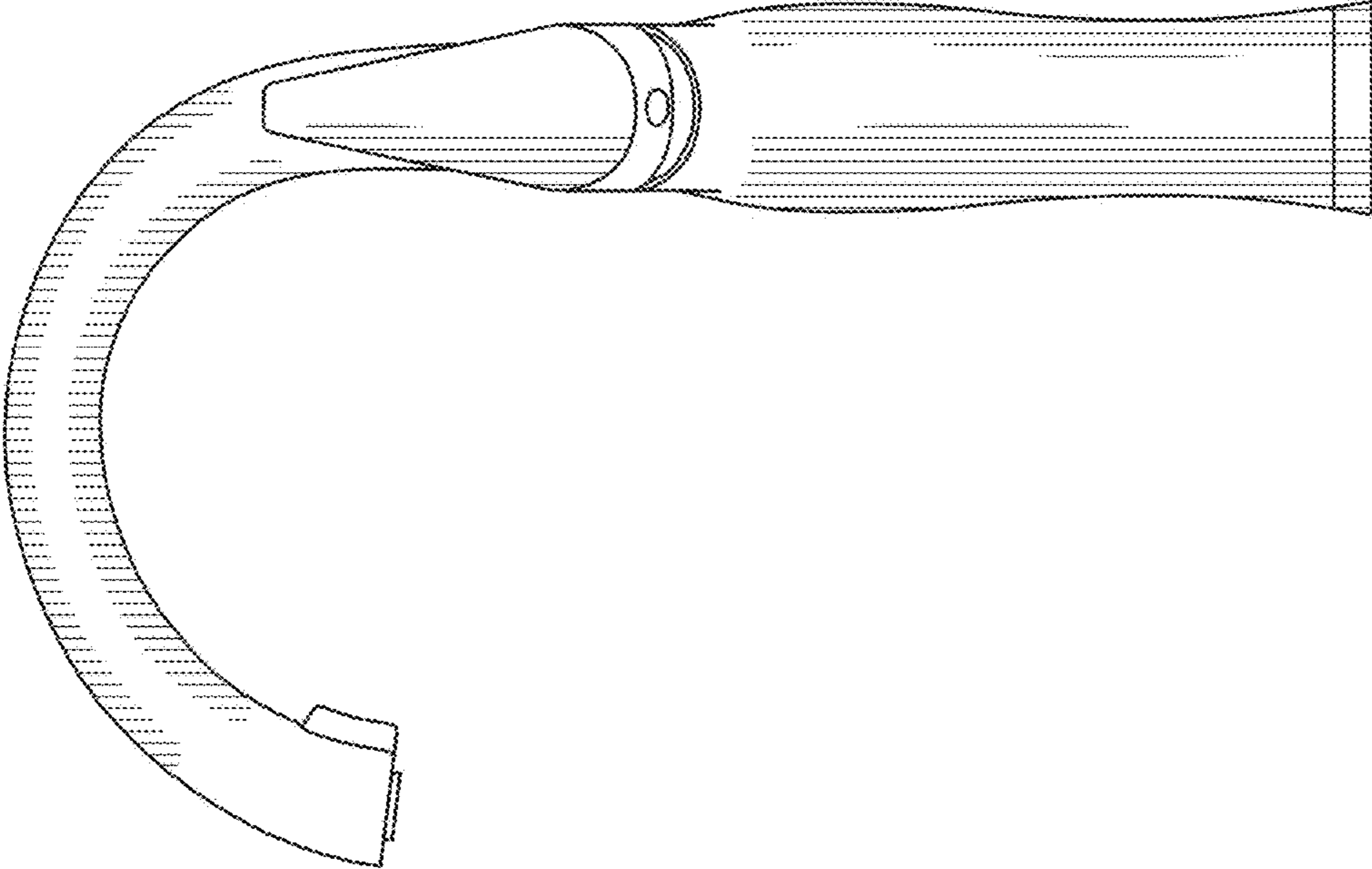

FIG. 7

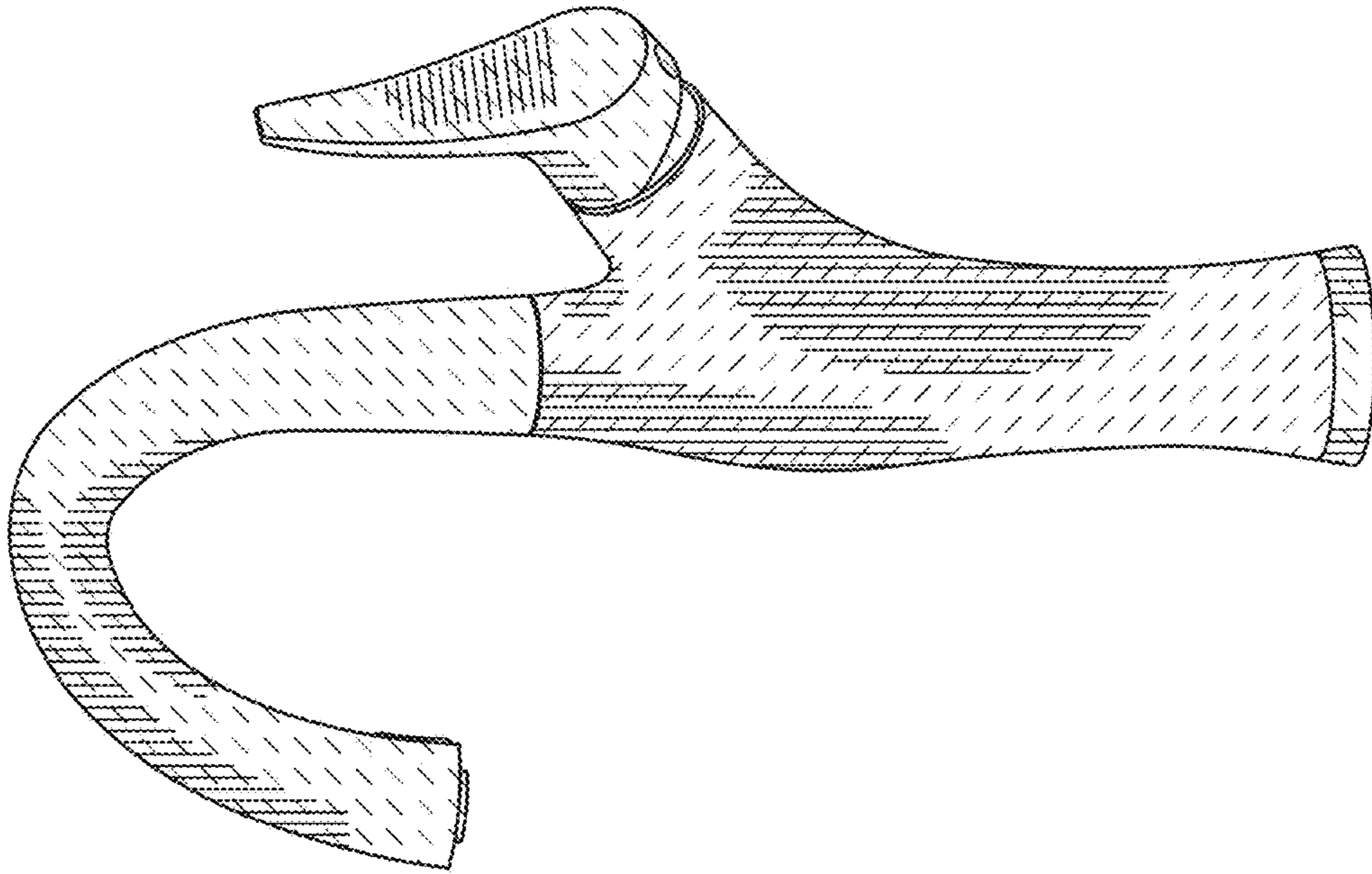

FIG. 8

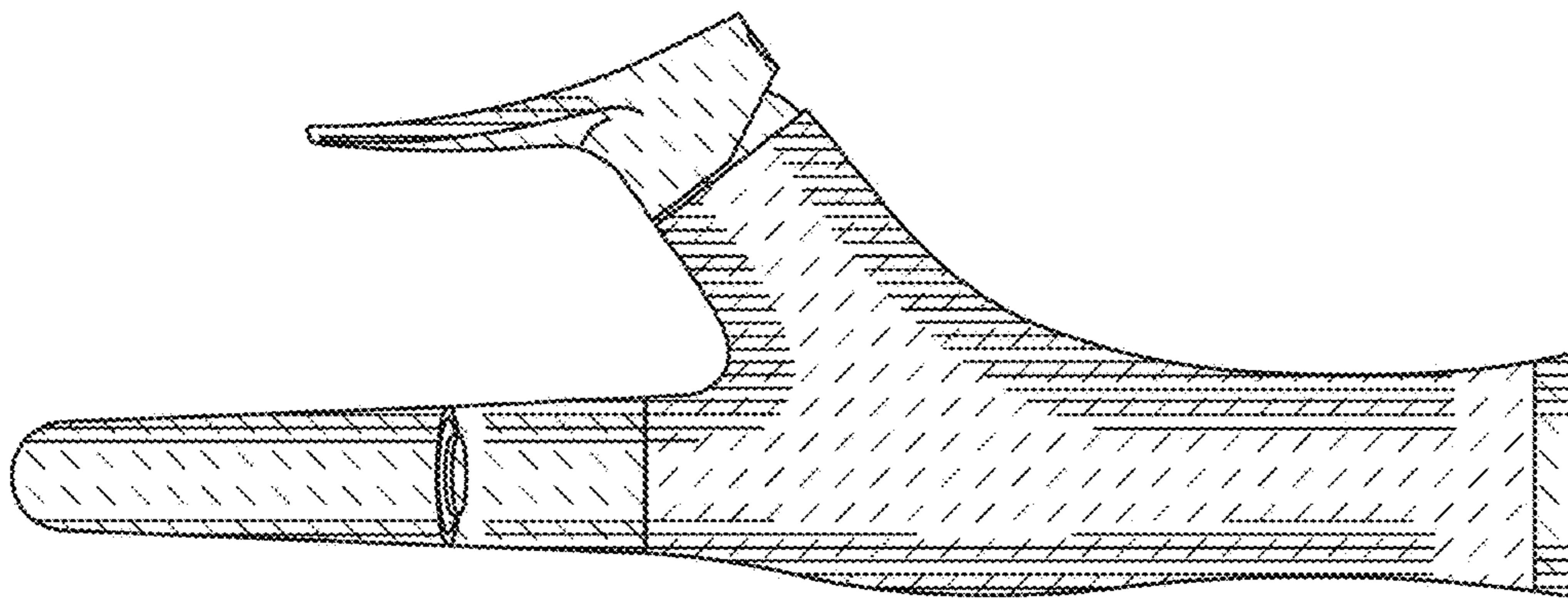

FIG. 9

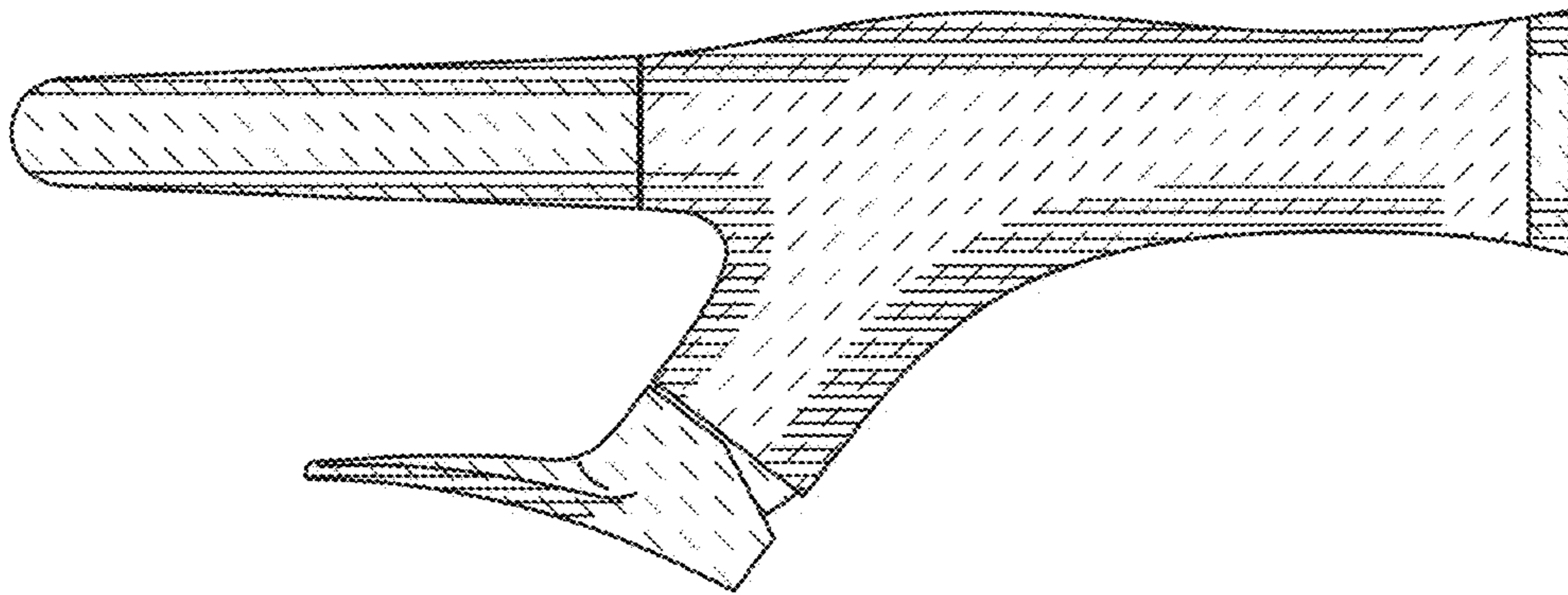

FIG. 10

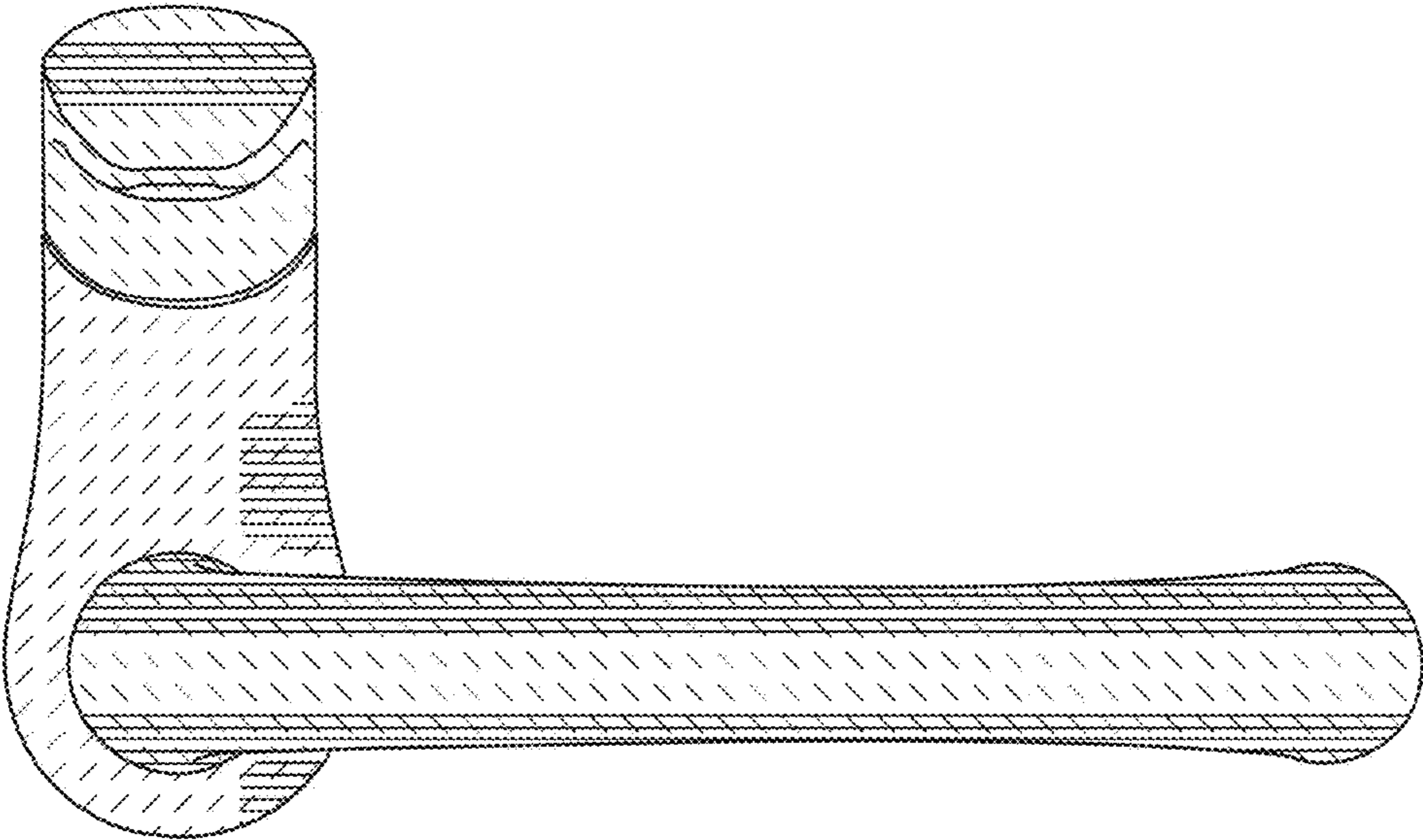

FIG. 11

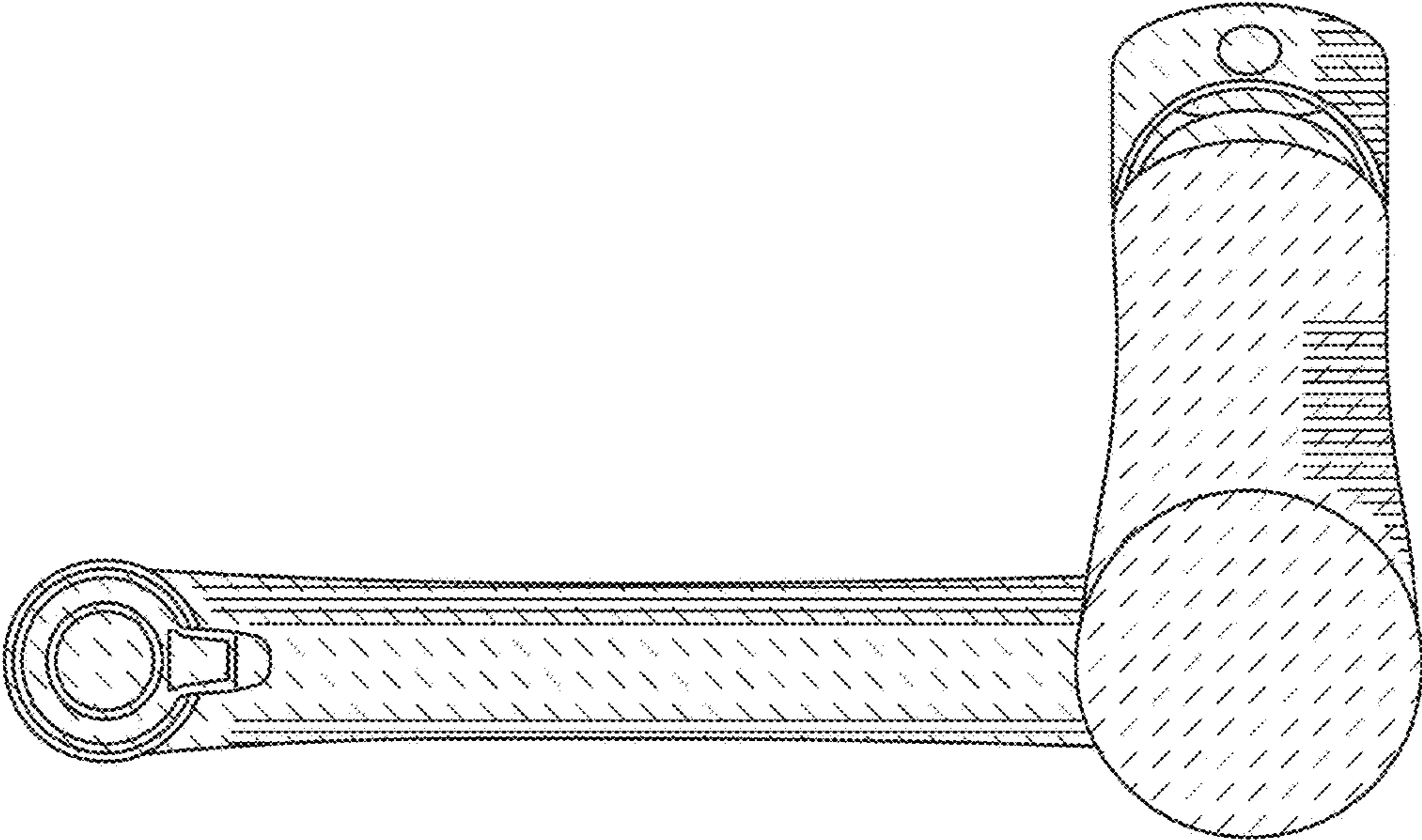

FIG. 12

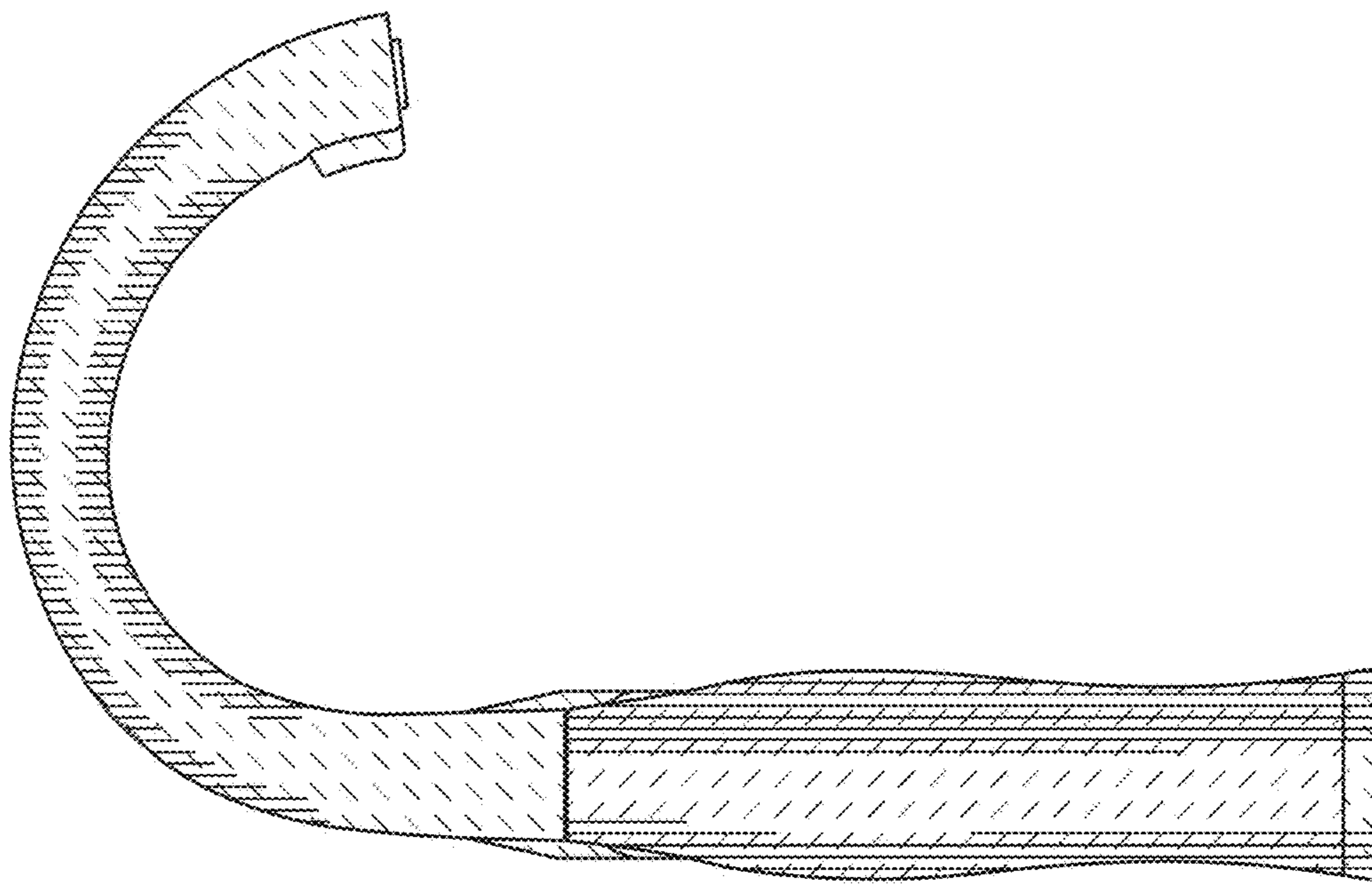

FIG. 13

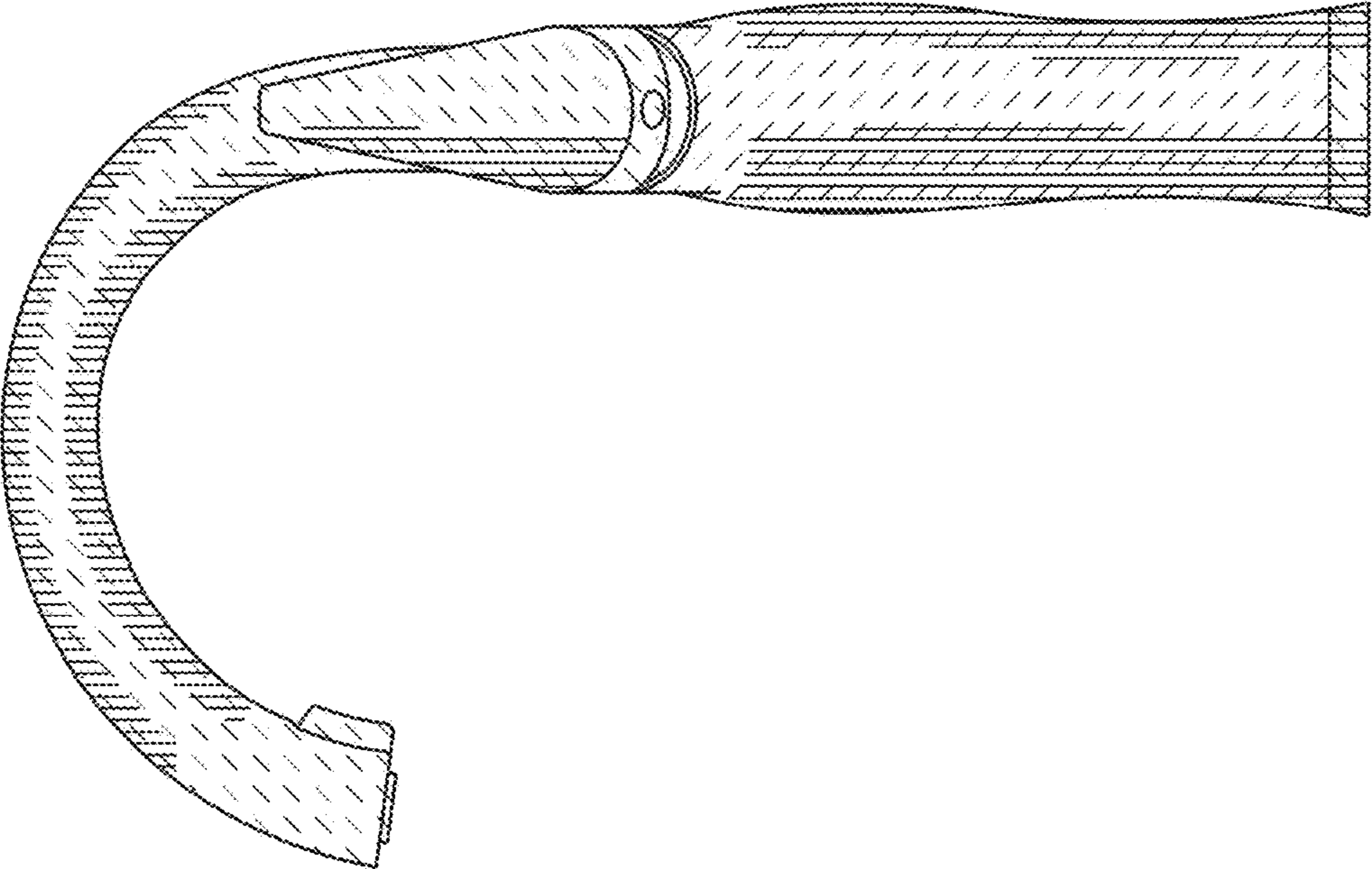

FIG. 14