



US00D788667S

(12) **United States Design Patent**
Dempsey

(10) **Patent No.:** **US D788,667 S**

(45) **Date of Patent:** **** Jun. 6, 2017**

(54) **AUTOMOBILE ENTRANCE HATCH**

(71) Applicant: **Robert Matthew Dempsey**, Carson City, NV (US)

(72) Inventor: **Robert Matthew Dempsey**, Carson City, NV (US)

(**) Term: **14 Years**

(21) Appl. No.: **29/496,043**

(22) Filed: **Jul. 9, 2014**

(51) **LOC (10) Cl.** **12-16**

(52) **U.S. Cl.**
USPC **D12/196; D12/183**

(58) **Field of Classification Search**
USPC D12/86, 90, 91, 92, 163, 169, 171, 183,
D12/196, 216; 293/102, 113, 115, 117,
293/120; 296/180.1, 180.2, 181.1, 181.5
CPC B62D 35/001; B62D 31/003; B62D 24/02;
B62D 25/08; B62D 33/00; B62D 25/06;
B60R 19/02
See application file for complete search history.

(56) **References Cited**

U.S. PATENT DOCUMENTS

4,973,082	A	*	11/1990	Kincheloe	B60R 21/13	280/756
D350,503	S	*	9/1994	Yang	D12/90	
D357,436	S	*	4/1995	Moar	D12/96	
D373,330	S	*	9/1996	Halajko	D12/90	
D390,163	S	*	2/1998	Tomforde	D12/91	
D422,254	S	*	4/2000	Toyoda	D12/196	
D580,330	S	*	11/2008	Gueler	D12/196	
D590,312	S	*	4/2009	Varga	D12/196	
D601,071	S	*	9/2009	Di Buduo	D12/196	
D615,905	S	*	5/2010	Arnell	D12/91	
D671,452	S	*	11/2012	Fernandez Isoird	D12/86	
D695,177	S	*	12/2013	Matsueda	D12/196	
D713,297	S	*	9/2014	Bose	D12/91	

OTHER PUBLICATIONS

“The Citroen C-ZERO, now available from 16300 in France”. Found online Feb. 4, 2016 at cleancarjournal.com. Page dated Feb. 9, 2012. Retrieved from <http://www.cleancarjournal.com/citroen-c-zero-battery-rental/>.*

“1961 Isetta 300 (British)”. Found online Feb. 4, 2016 at microcarmuseum.com. Page dated 2002. Retrieved from <http://www.microcarmuseum.com/tour/isetta-gb.html>.*

“Hitachi Comes Out with New Vehicle for Disabled and Elderly”. Found online Feb. 4, 2016 at boombotix.com. Page dated Mar. 28, 2013. Retrieved from <https://boombotix.com/blog/2013/03/28/new-one-person-self-driving-cars-hit-sidewalks-in-japan/>.*

“The Concept for the BMW Mega City Vehicle is the iSetta?” Found online Feb. 4, 2016 at bmwblog.com. Page dated Apr. 5, 2010. Retrieved from <http://www.bmwblog.com/2010/04/05/the-concept-for-the-bmw-mega-city-vehicle-is-the-isetta/>.*

* cited by examiner

Primary Examiner — Robert M Spear

Assistant Examiner — Kendra L Hamilton

(74) *Attorney, Agent, or Firm* — Eric F. Taylor

(57) **CLAIM**

The ornamental design for an automobile entrance hatch, as shown and described.

DESCRIPTION

FIG. 1 is a front, top perspective view of an automobile entrance hatch, in a closed configuration, showing the new design;

FIG. 2 is a front elevational view thereof;

FIG. 3 is a right side elevational view thereof;

FIG. 4 is a top plan view thereof;

FIG. 5 is a front, top perspective view thereof, shown in an open configuration of use;

FIG. 6 is a front elevational view thereof;

FIG. 7 is a right side elevational view thereof; and,

FIG. 8 is a top view thereof.

The broken lines in the drawings illustrate portions of the automobile that form no part of the claimed design.

1 Claim, 8 Drawing Sheets

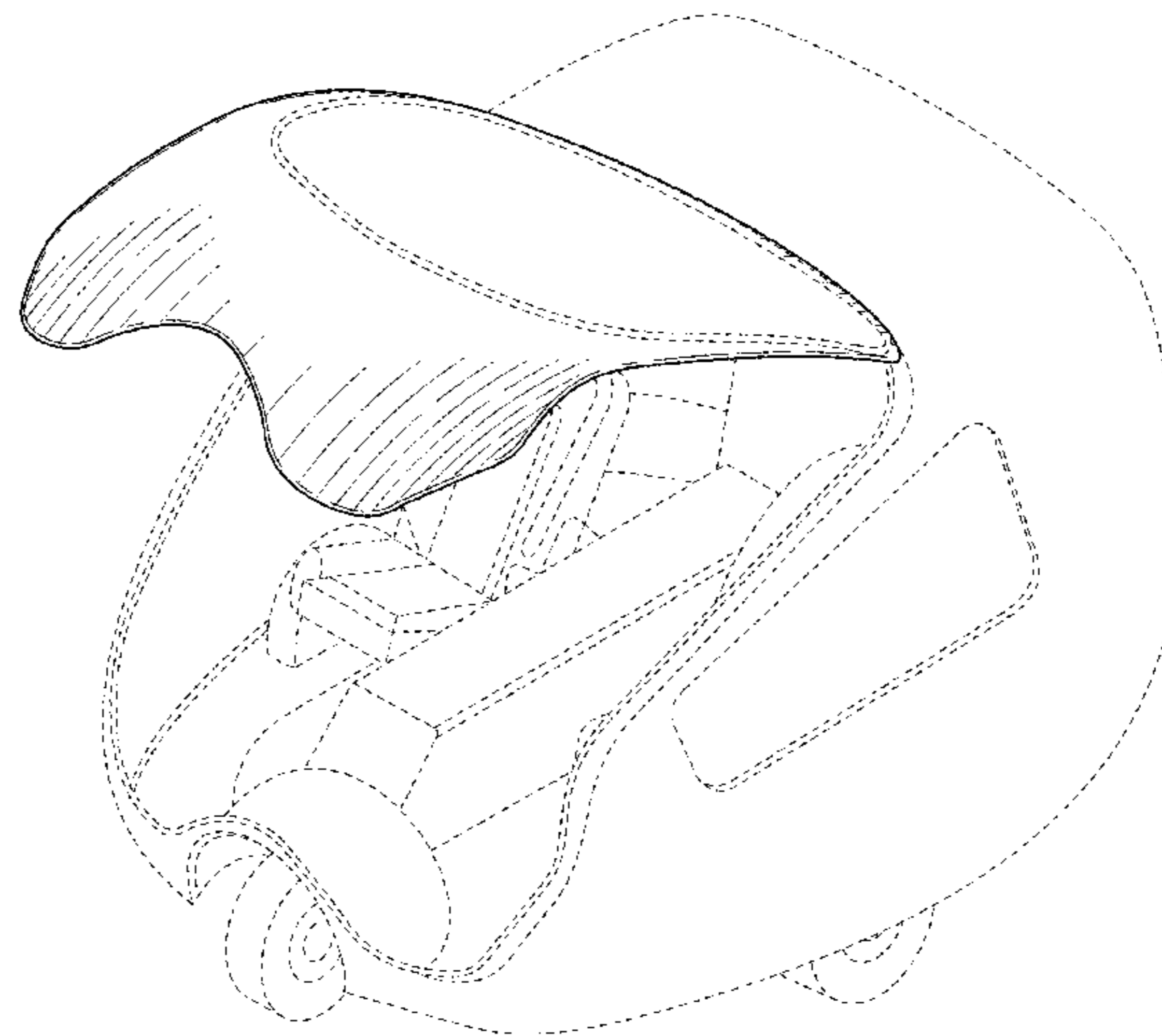
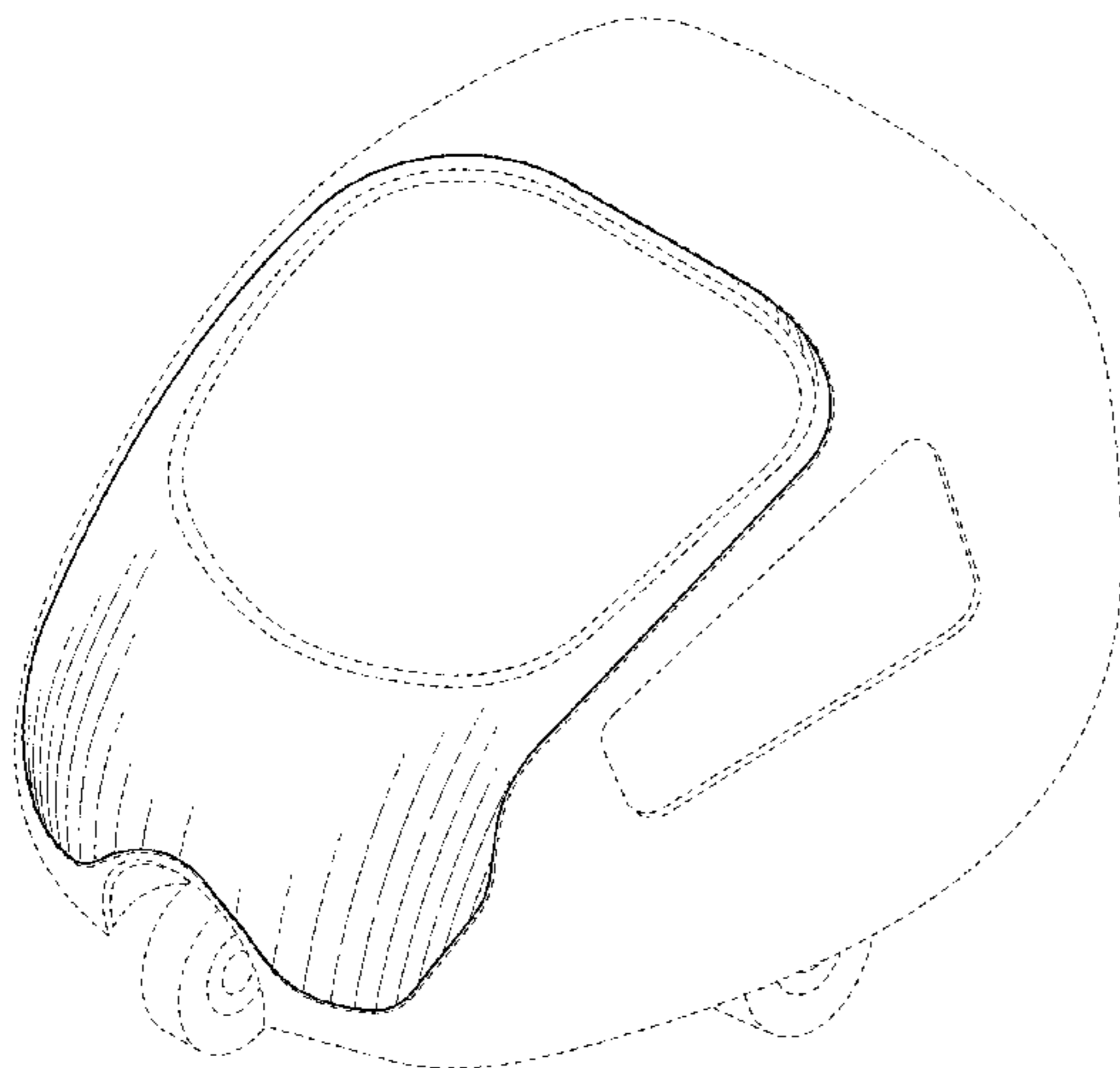

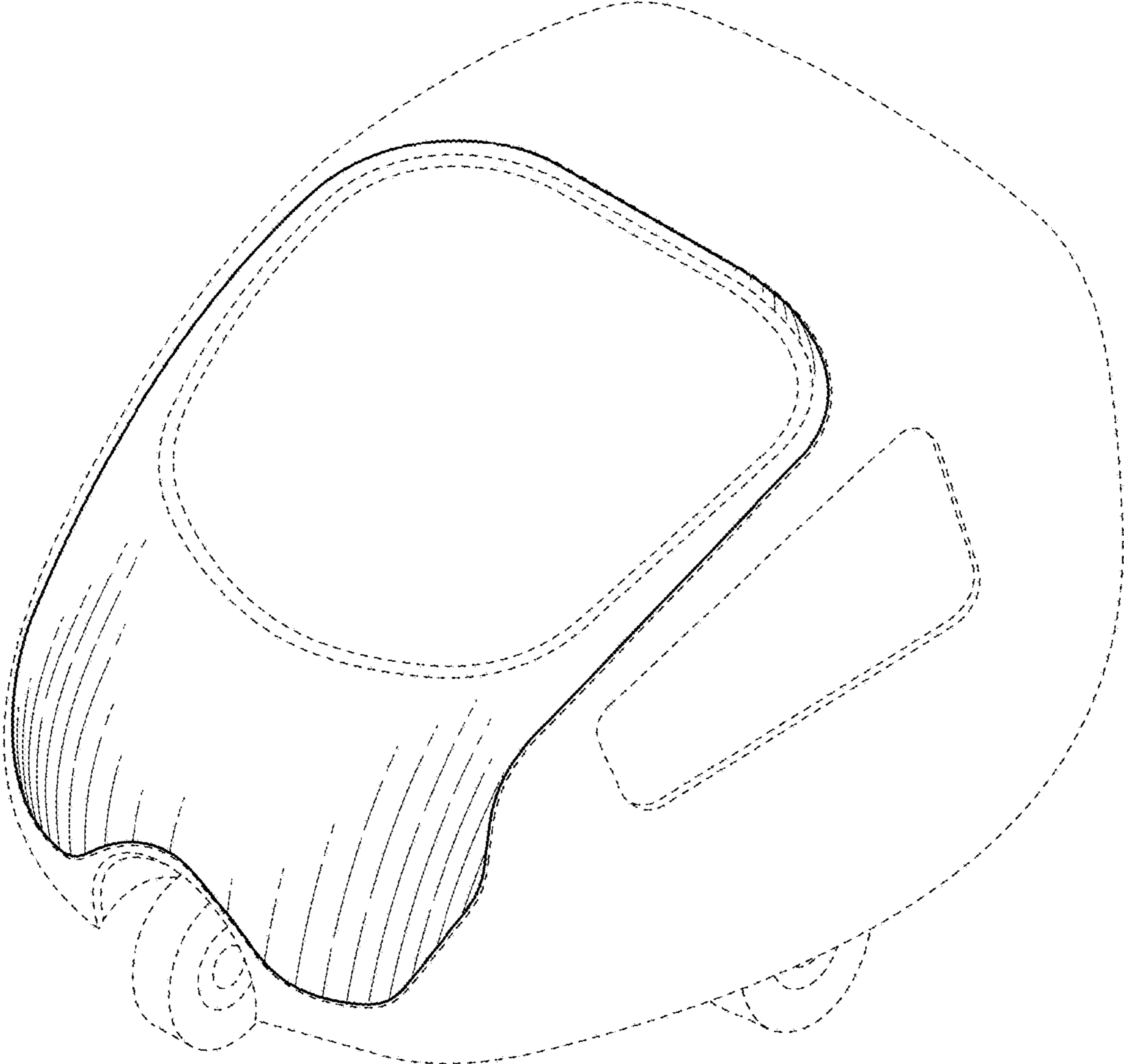

FIG. 1

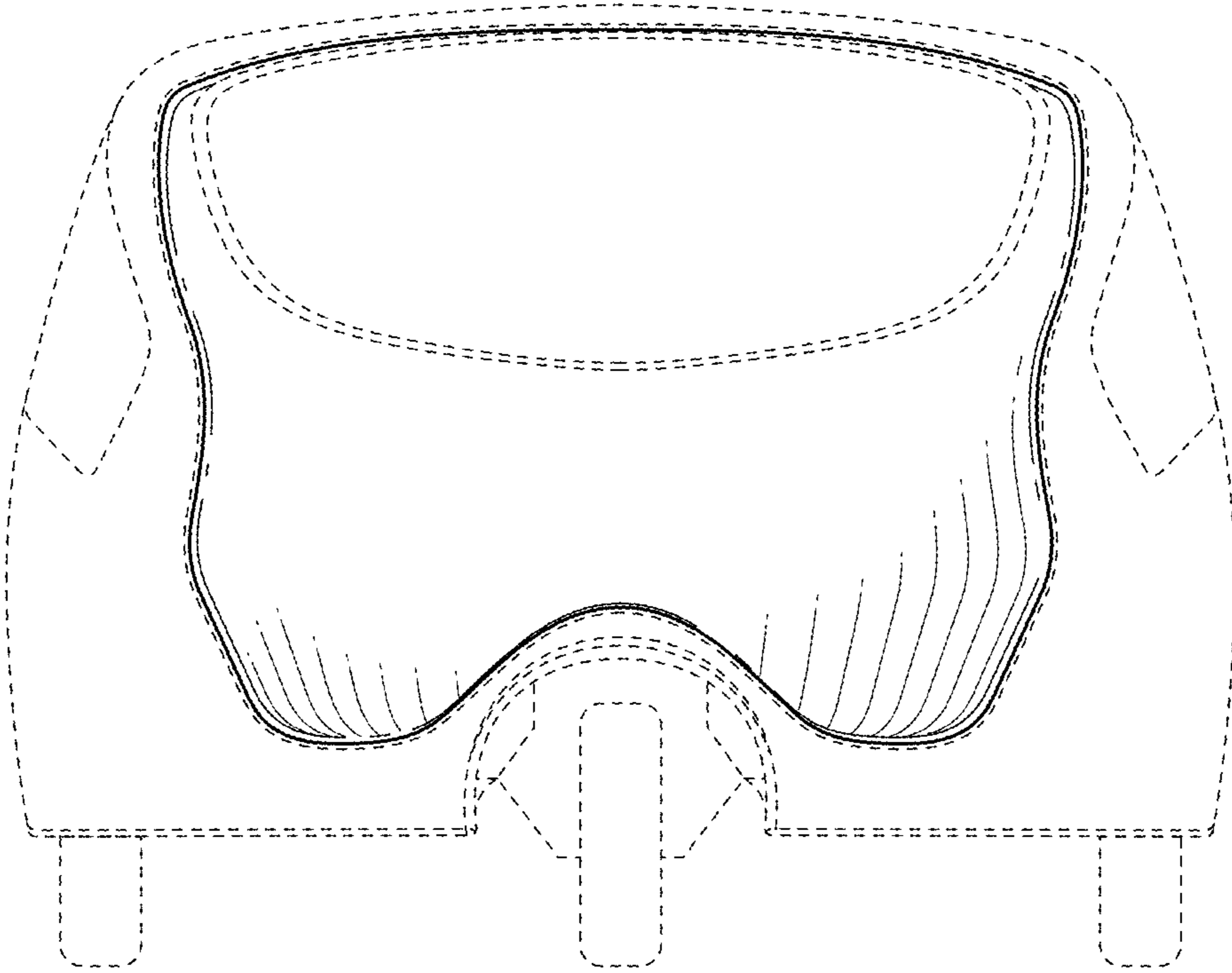

FIG. 2

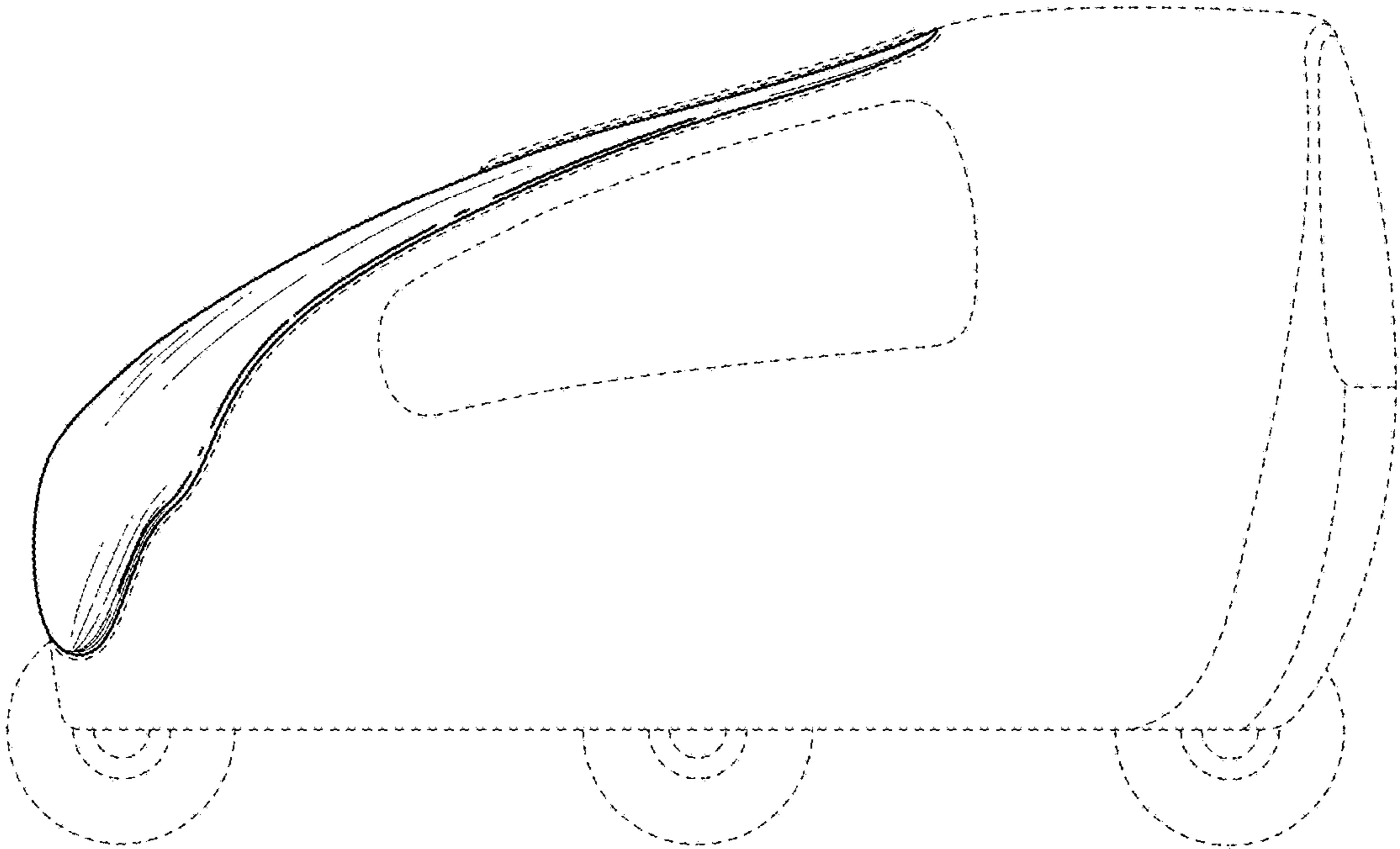

FIG. 3

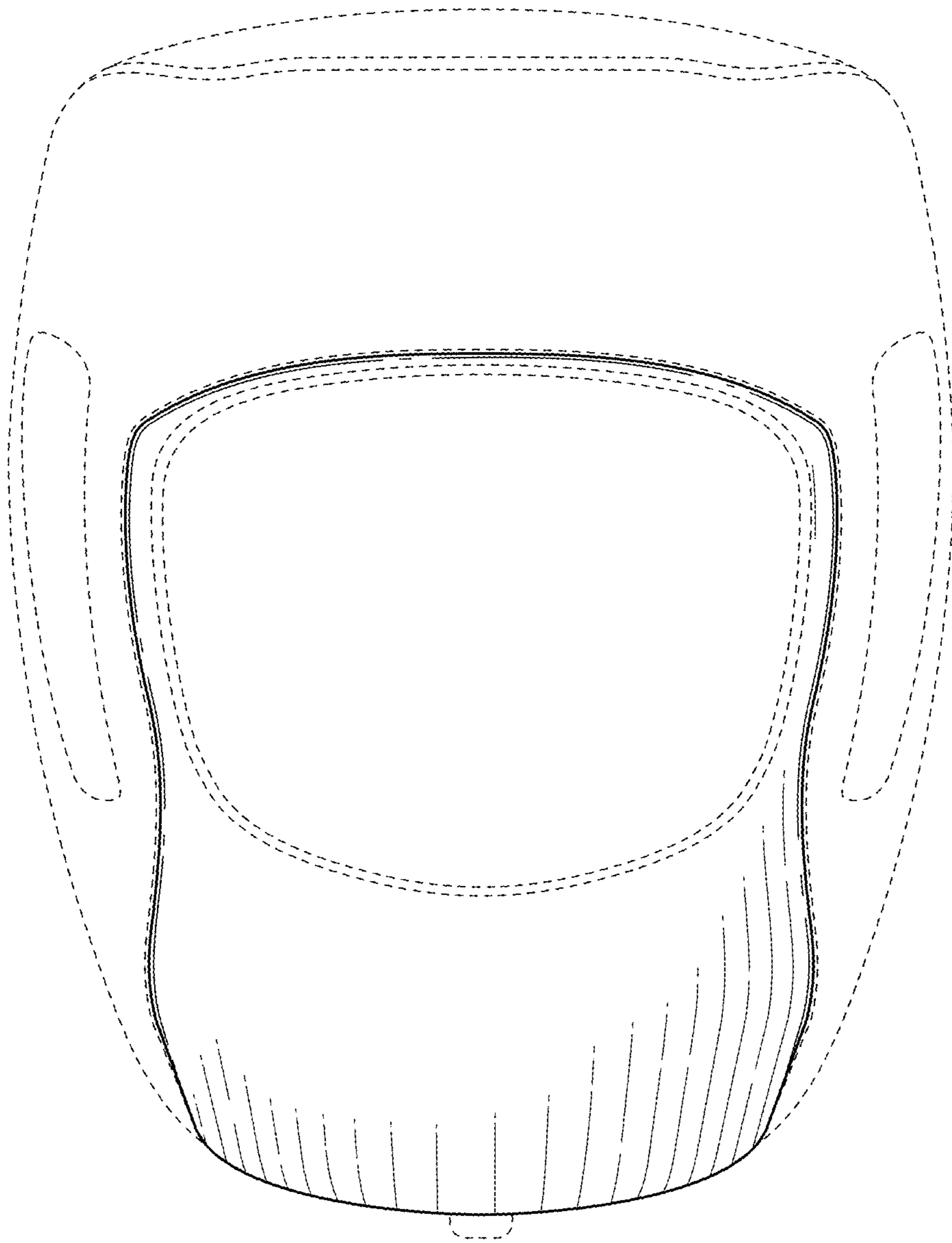

FIG. 4

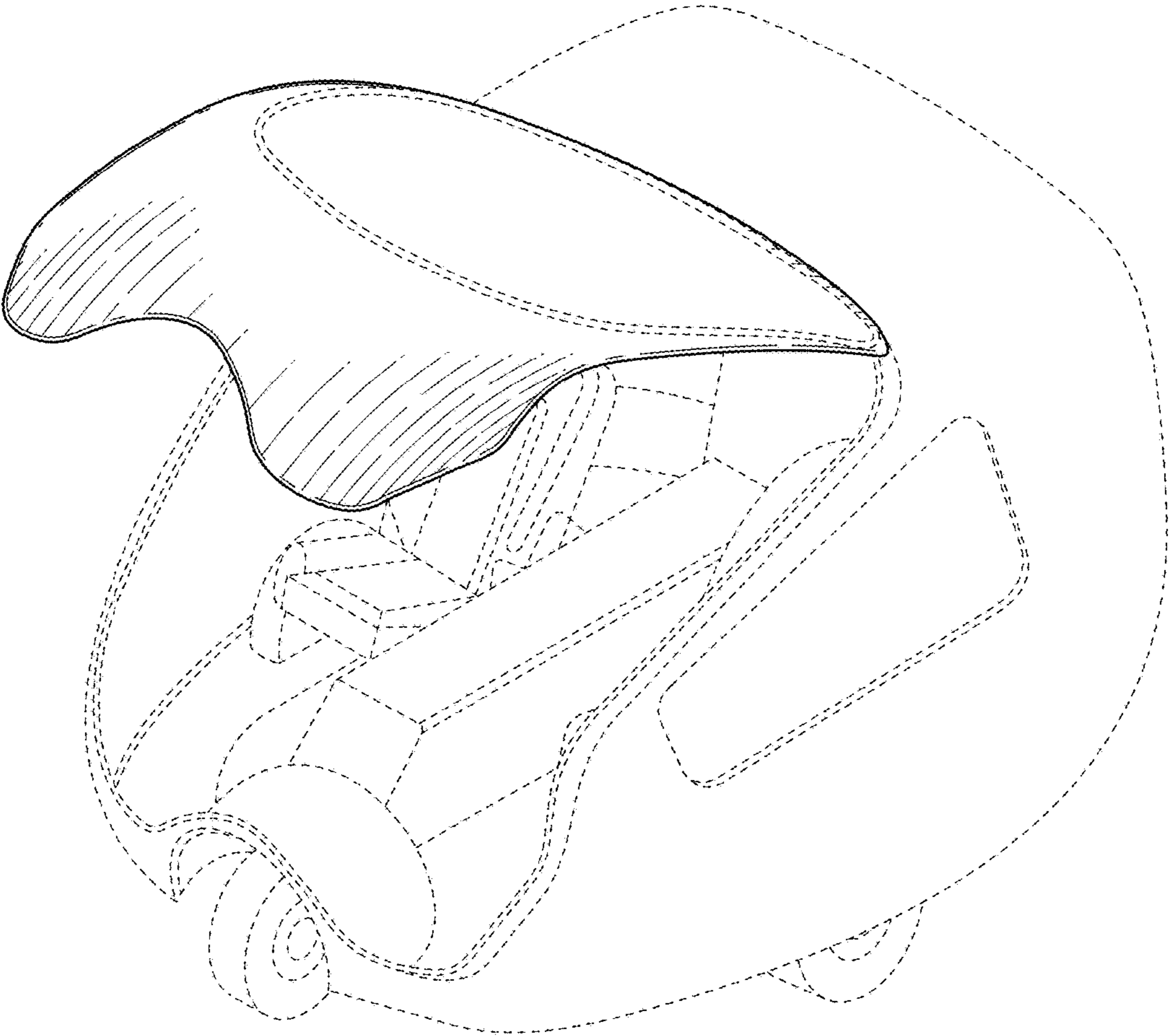

FIG. 5

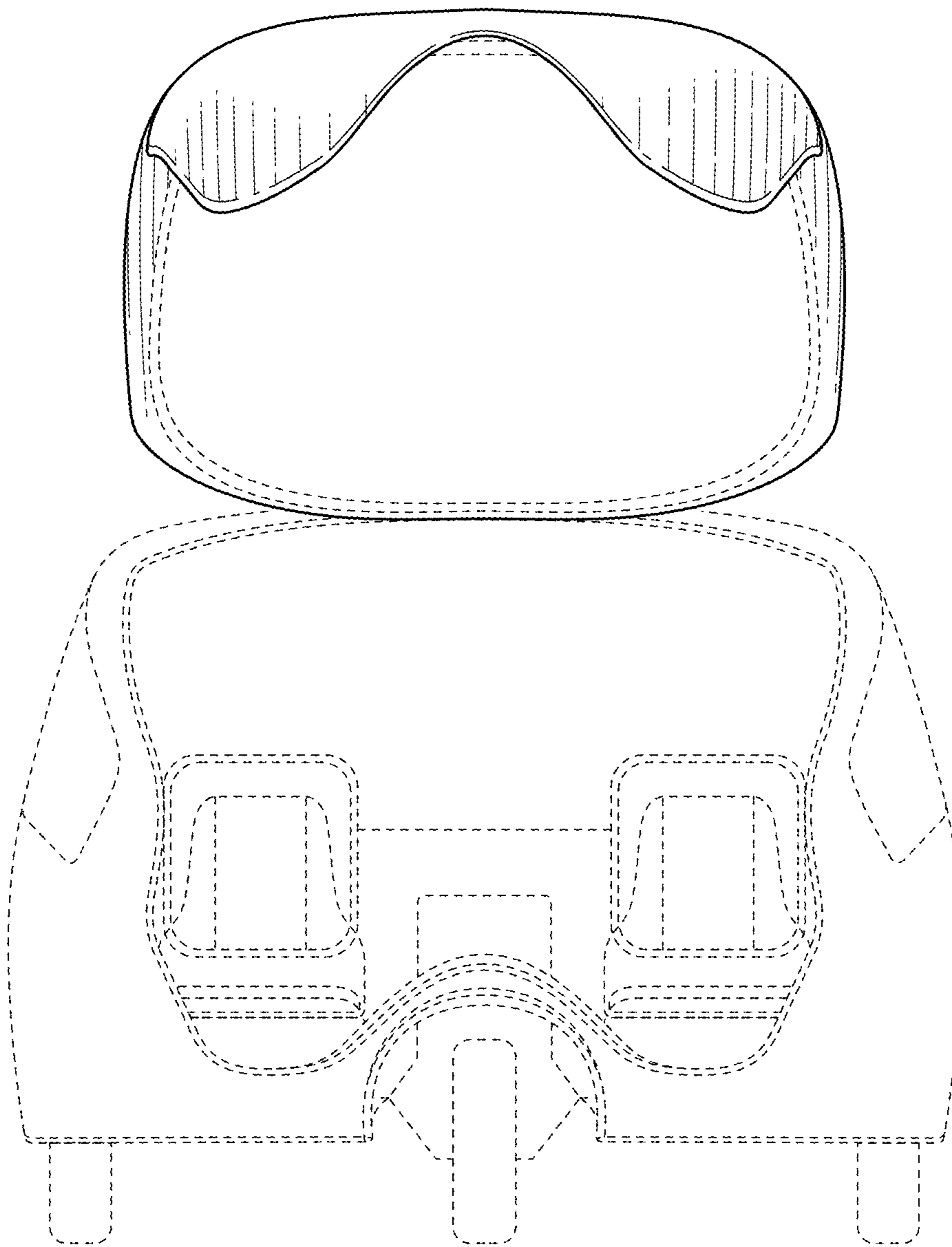

FIG. 6

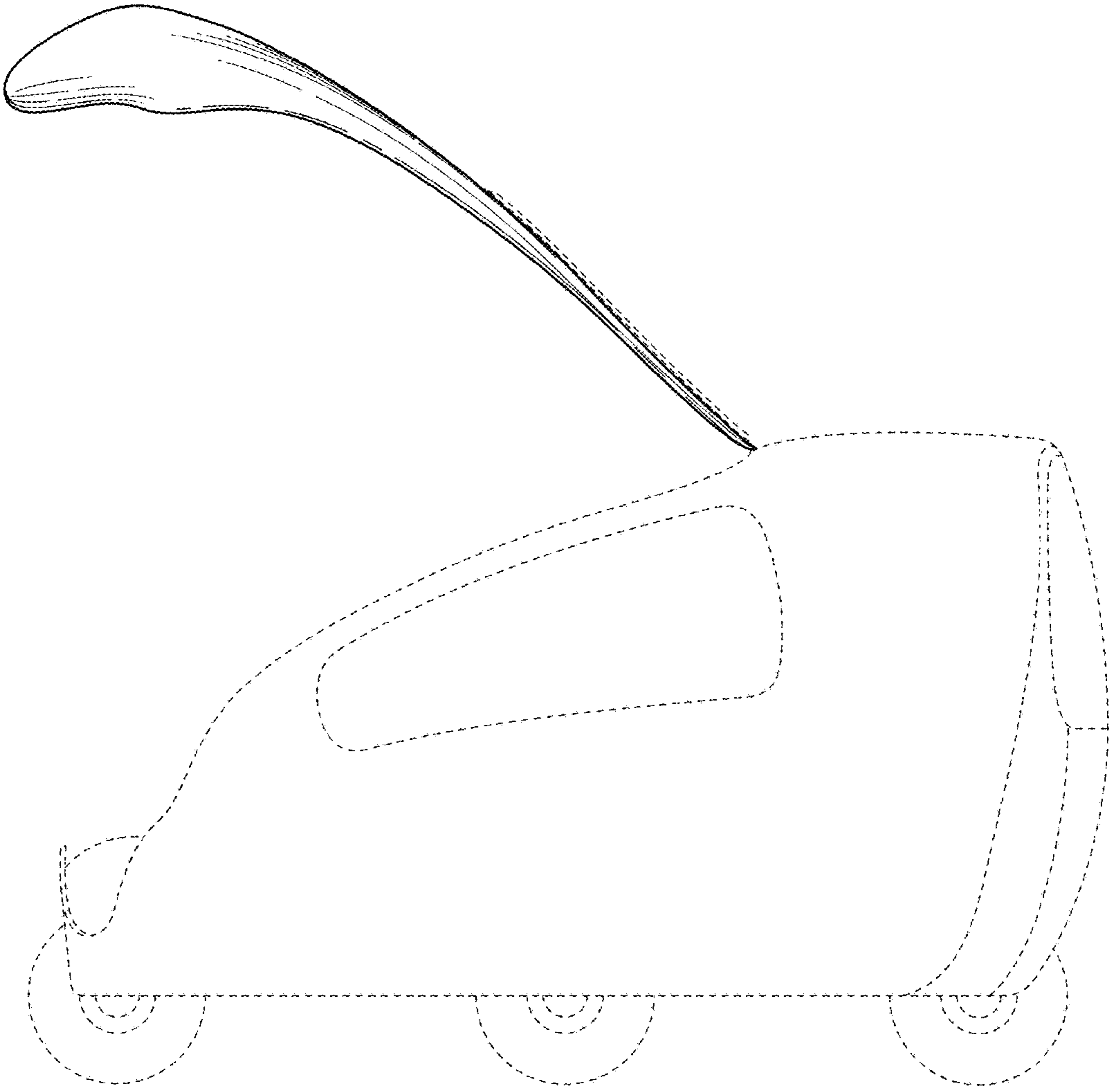

FIG. 7

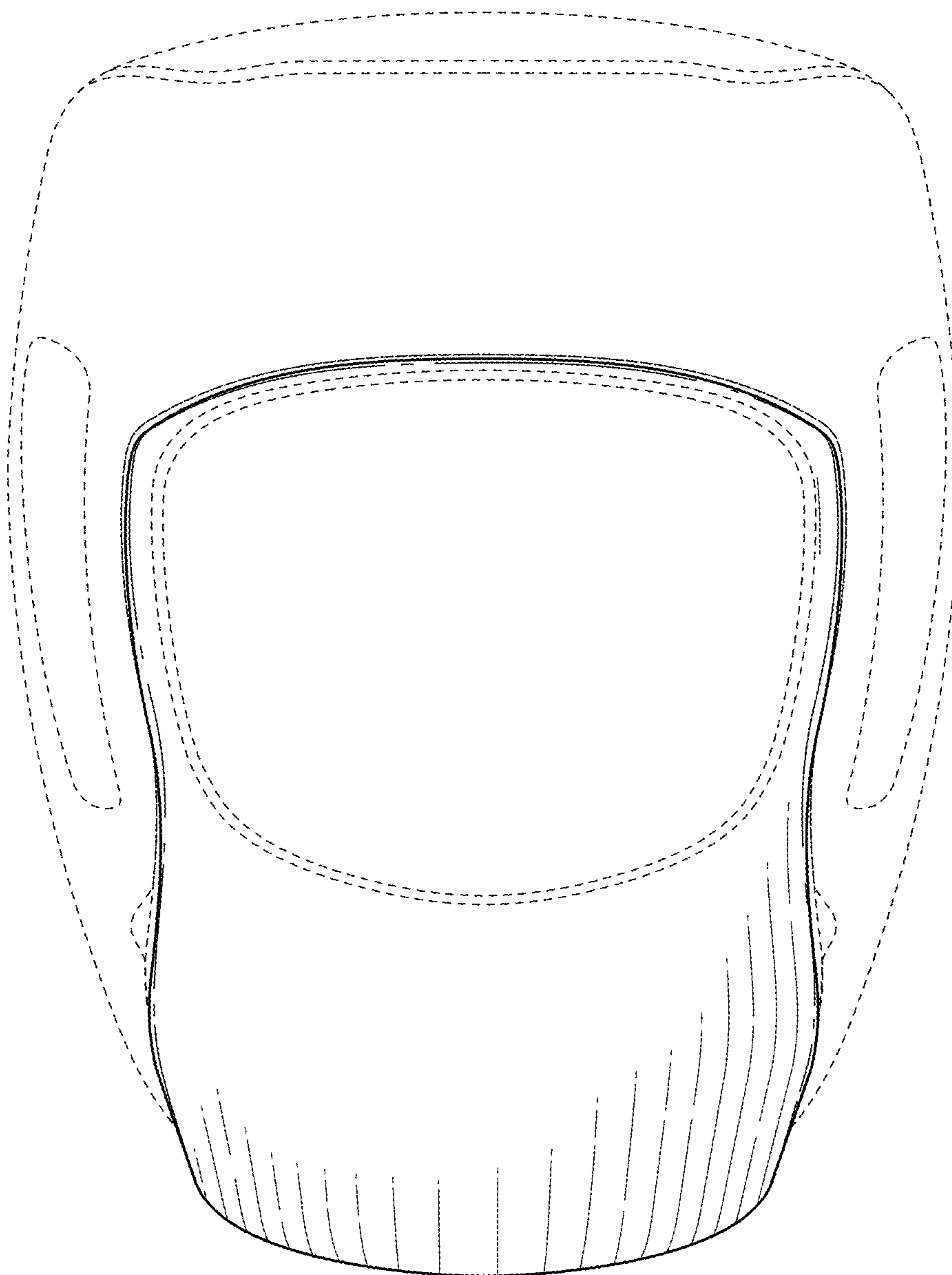

FIG. 8