



US00D788311S

(12) **United States Design Patent** (10) **Patent No.:** **US D788,311 S**  
**Sanga** (45) **Date of Patent:** **\*\* May 30, 2017**

(54) **PORTABLE DENTAL EQUIPMENT** 6,464,497 B2 \* 10/2002 Landoz ..... A61C 5/025  
 206/369  
 (71) Applicant: **Toshinari Sanga**, Kanuma (JP) D554,757 S \* 11/2007 Haymann ..... D14/389  
 8,342,841 B2 \* 1/2013 Vogel ..... A61C 19/02  
 (72) Inventor: **Toshinari Sanga**, Kanuma (JP) 8,631,931 B2 \* 1/2014 Patenaude ..... A61C 19/02  
 206/362  
 (73) Assignee: **Nakanishi Inc.**, Kanuma-shi (JP) 2006/0204922 A1 \* 9/2006 Anderson ..... A61C 1/0053  
 206/63.5  
 433/77  
 (\*\*) Term: **15 Years**

(21) Appl. No.: **29/532,265**  
 (22) Filed: **Jul. 3, 2015**  
 (51) **LOC (10) Cl.** ..... **24-01**  
 (52) **U.S. Cl.**  
 USPC ..... **D24/176**  
 (58) **Field of Classification Search**  
 USPC ..... D24/176–179, 231–232; D3/201, 203.1,  
 D3/273–274, 294; 433/49, 53, 59, 72,  
 433/77; 206/369–370  
 CPC ..... A61C 1/0053; A61C 19/02; A61C 5/025  
 See application file for complete search history.

(56) **References Cited**  
**U.S. PATENT DOCUMENTS**  
 2,984,344 A \* 5/1961 Weissman ..... A61C 19/02  
 206/63.5  
 D221,380 S \* 8/1971 Chasen et al. .... D24/177  
 3,936,937 A \* 2/1976 Gordon ..... A61C 19/02  
 433/77  
 D346,658 S \* 5/1994 Bailey ..... D24/177  
 D360,466 S \* 7/1995 Nordstrom ..... D24/176  
 5,536,084 A \* 7/1996 Curtis ..... 433/77  
 6,450,328 B1 \* 9/2002 Machacek ..... A61C 19/02  
 206/45.2

**FOREIGN PATENT DOCUMENTS**

JP D1481252 \* 10/2012  
 \* cited by examiner

*Primary Examiner* — Wan Laymon  
 (74) *Attorney, Agent, or Firm* — Jason D. Voight

(57) **CLAIM**

The ornamental design for a portable dental equipment, as shown and described.

**DESCRIPTION**

FIG. 1 is a perspective view of a portable dental equipment;  
 FIG. 2 is a front view thereof;  
 FIG. 3 is a rear view thereof;  
 FIG. 4 is a top plan view thereof;  
 FIG. 5 is a bottom view thereof;  
 FIG. 6 is a right side view thereof; and,  
 FIG. 7 is a left side view thereof.  
 The portions of the portable dental equipment shown in broken lines form no part of the claimed design.

**1 Claim, 4 Drawing Sheets**

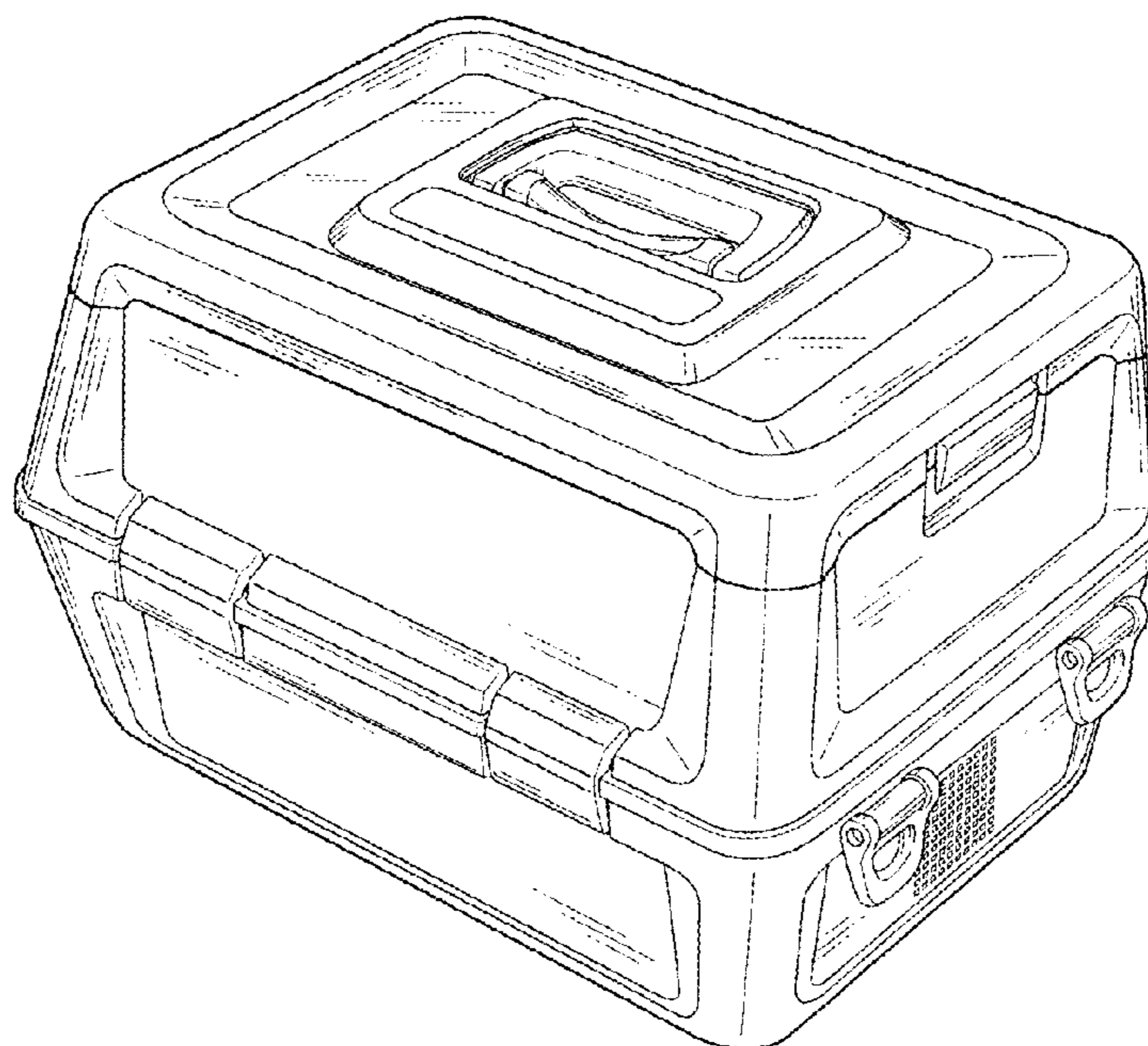

FIG. 1

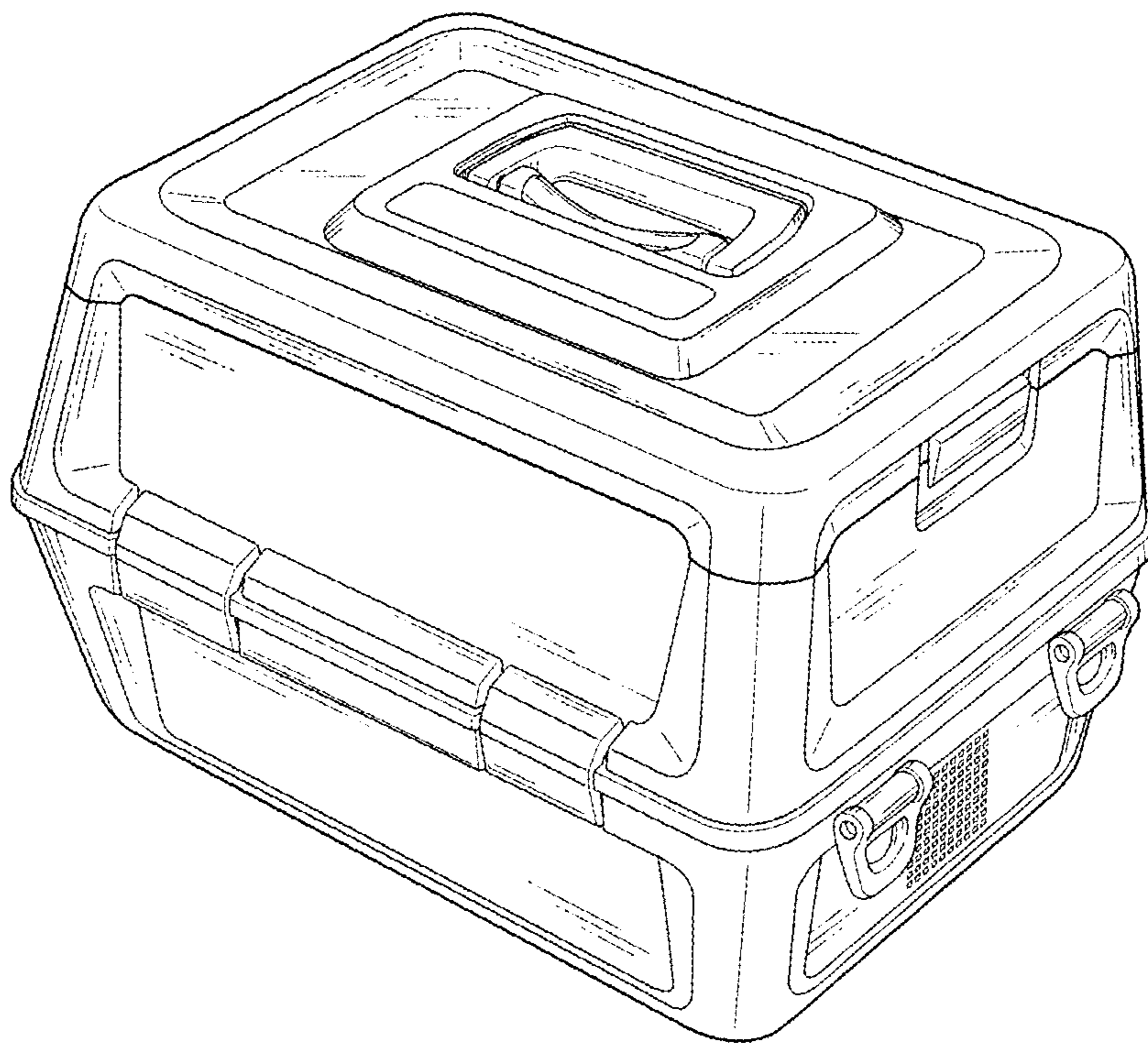

FIG.2

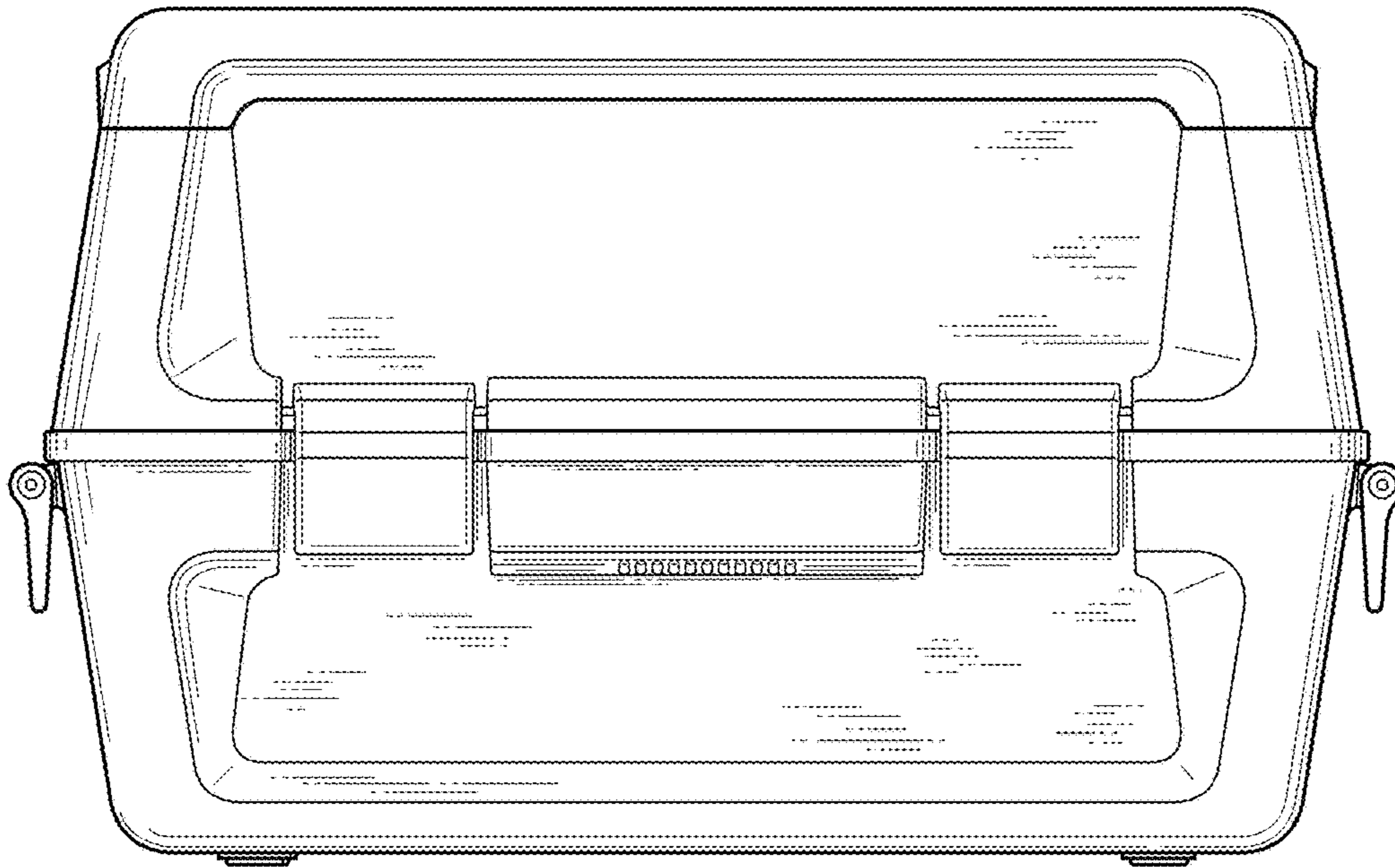

FIG.3

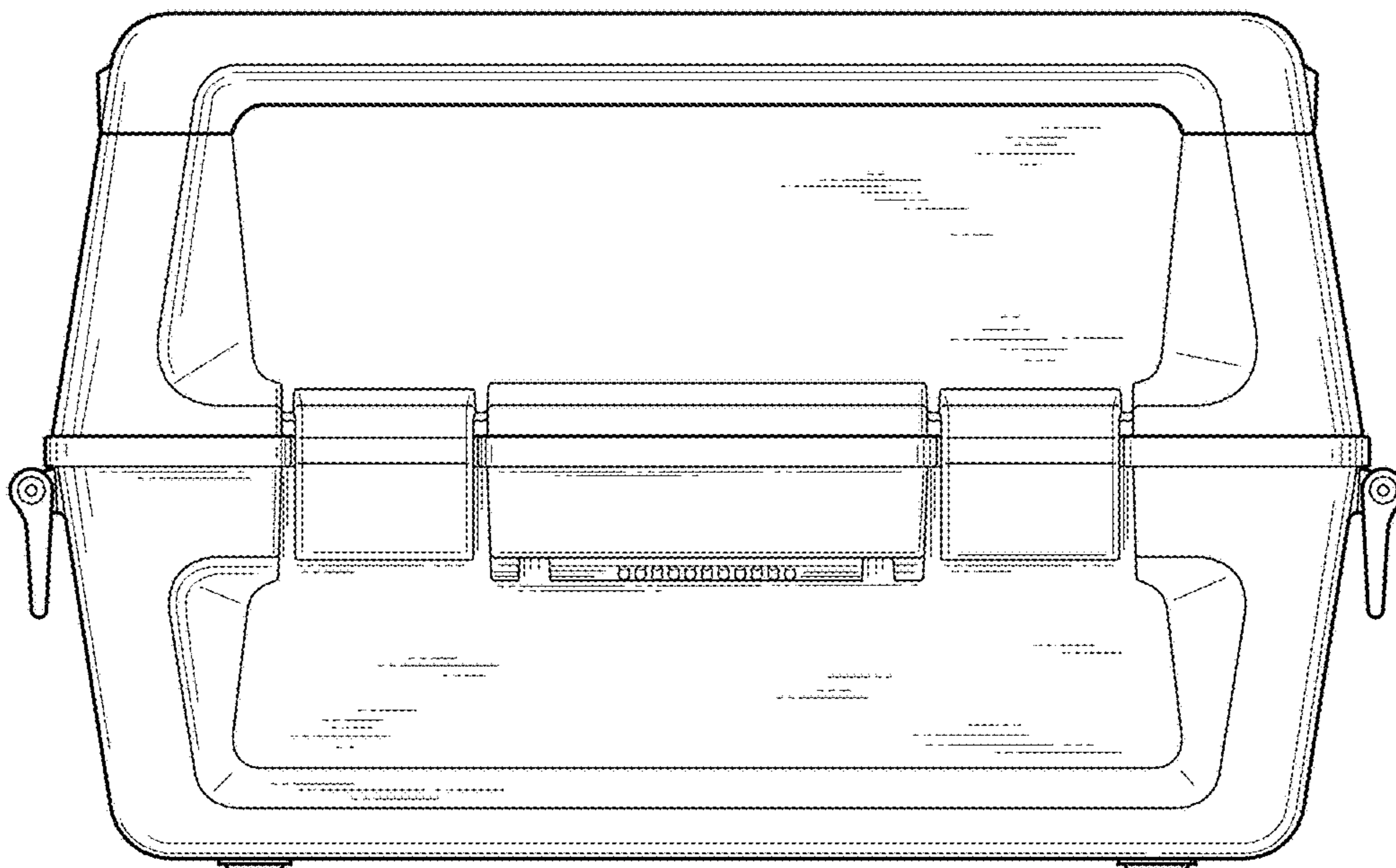

FIG.4

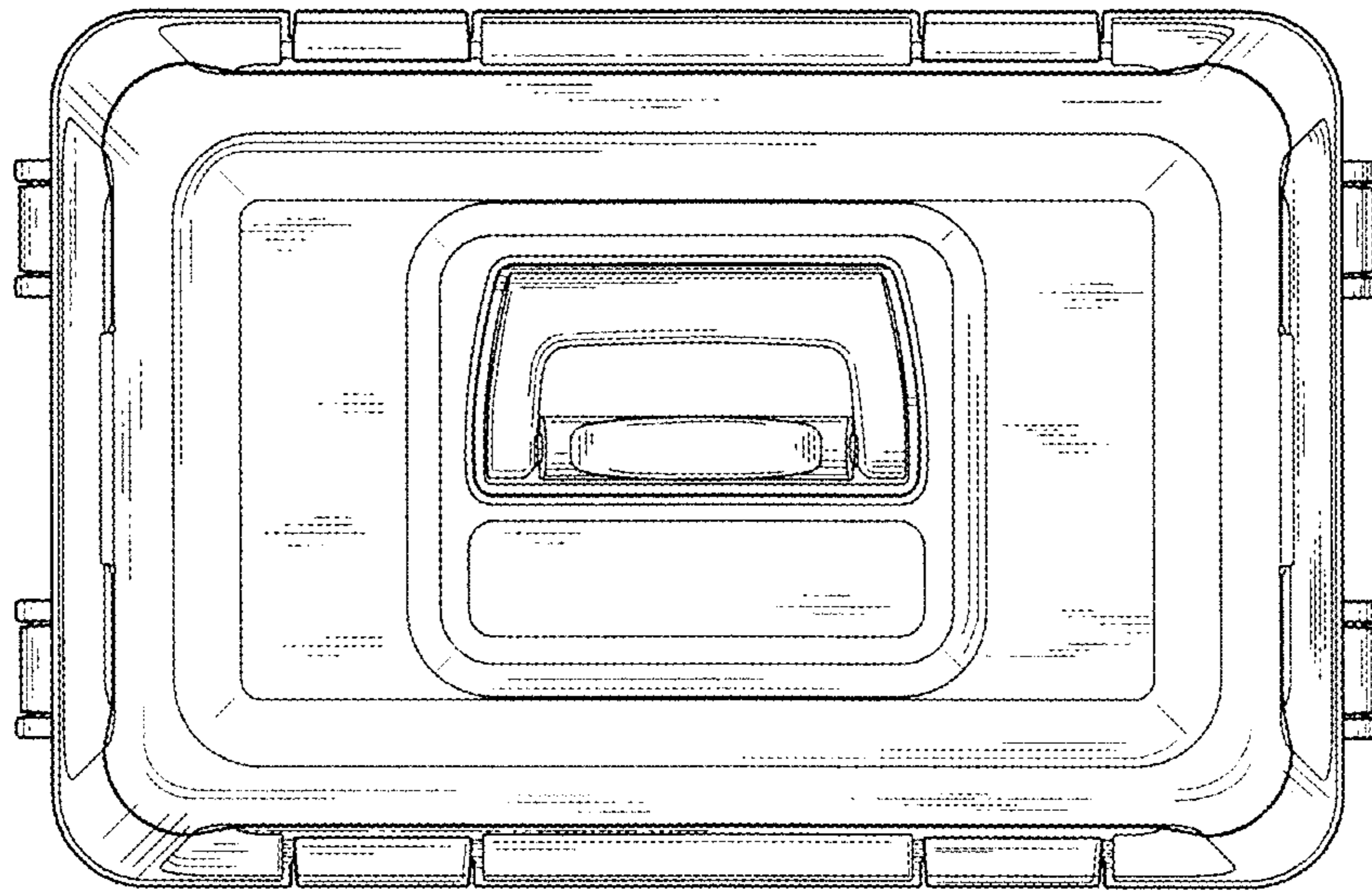

FIG.5

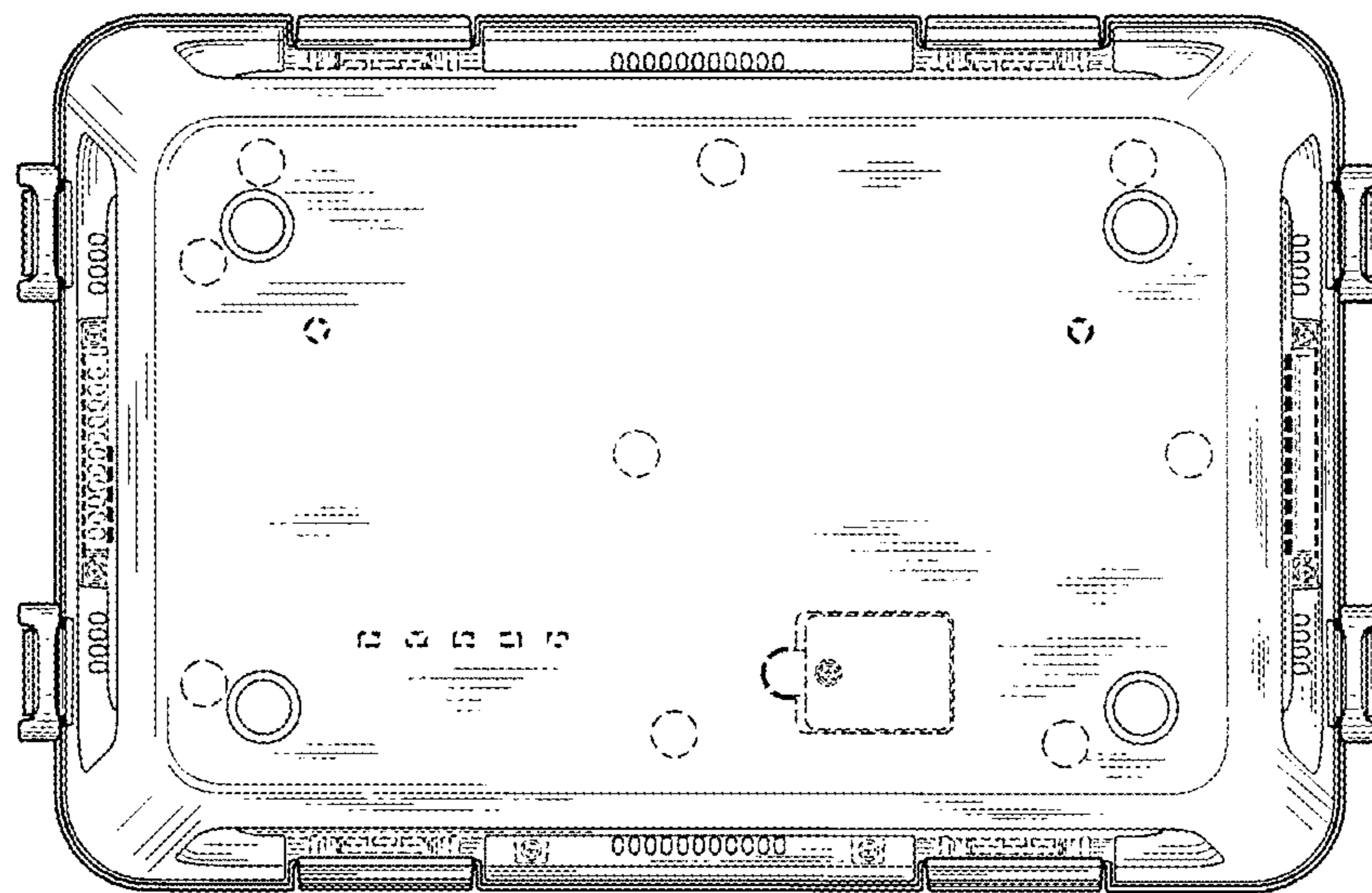

FIG.6

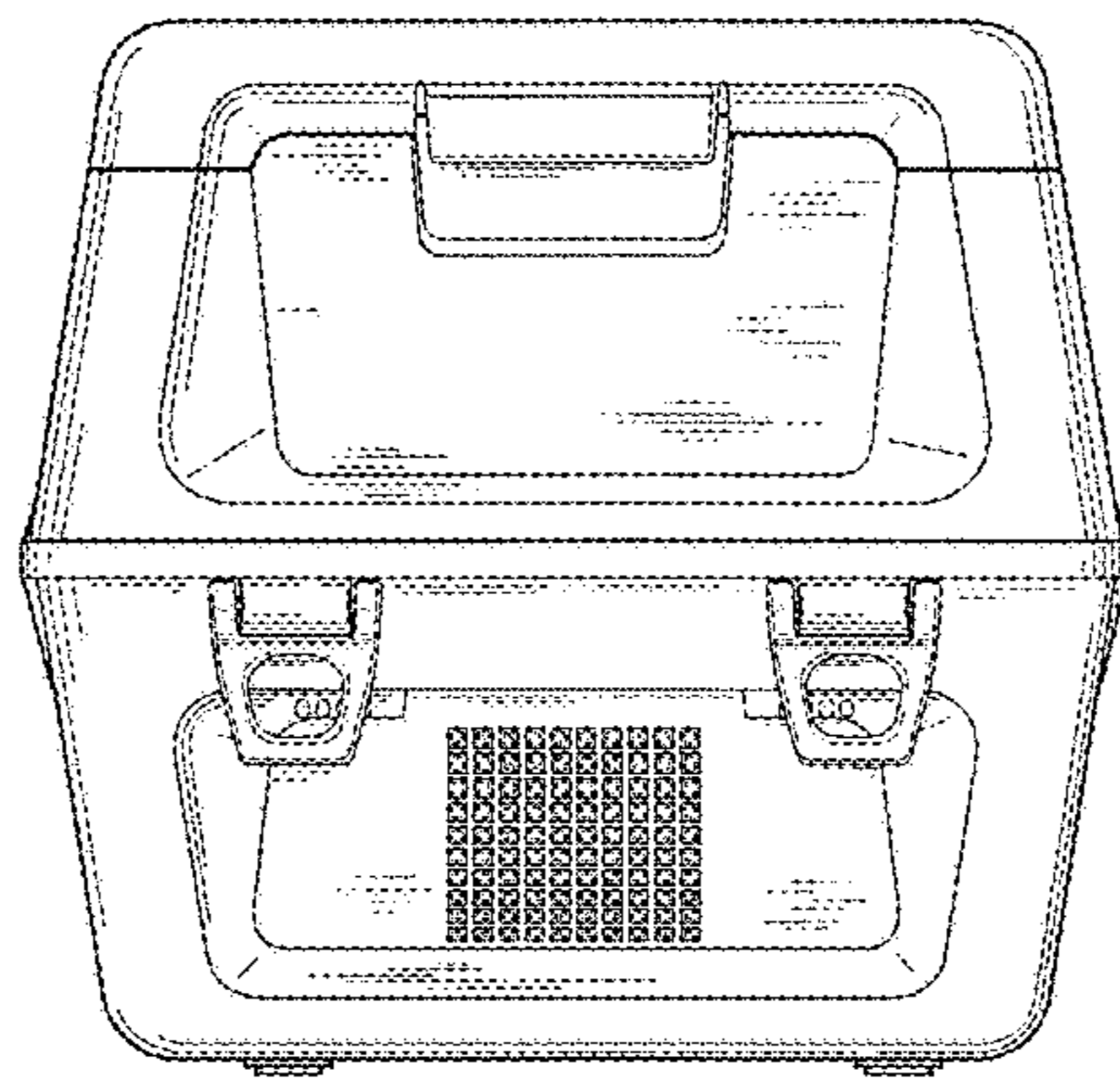

FIG.7

