



US00D788226S

(12) **United States Design Patent**  
**Lueken**

(10) **Patent No.:** **US D788,226 S**  
(45) **Date of Patent:** **\*\* May 30, 2017**

(54) **PAIR OF ADVERTISING PANELS WITH  
RECTANGULAR MARKER FOR SHOPPING  
CART CORRAL**

FOREIGN PATENT DOCUMENTS

CA 2848905 3/2013  
CN 203054922 7/2013

(Continued)

(71) Applicant: **Starlite Media, LLC**, New York, NY  
(US)

(72) Inventor: **Harold Lueken**, New York, NY (US)

(73) Assignee: **Starlite Media, LLC**, New York, NY  
(US)

(\*\*) Term: **14 Years**

(21) Appl. No.: **29/518,912**

(22) Filed: **Feb. 27, 2015**

(51) **LOC (10) Cl.** ..... **20-03**

(52) **U.S. Cl.**  
USPC ..... **D20/19; D20/42**

(58) **Field of Classification Search**  
USPC ..... D20/10, 19, 39, 40, 42, 99; D10/113.4;  
D6/300; D25/1, 18, 22, 32, 199  
CPC ..... G09F 7/00; G09F 7/08; G09F 9/00; G09F  
13/00; G09F 15/00; G09F 15/025; G09F  
15/0068; A47F 10/04; E04F 19/00  
See application file for complete search history.

(56) **References Cited**

U.S. PATENT DOCUMENTS

519,256 A \* 5/1894 Greene ..... G09F 3/20  
40/651  
D31,832 S 11/1899 Marcus  
1,927,997 A 9/1933 Weston  
2,165,724 A 7/1939 Le  
2,833,069 A \* 5/1958 Cairns ..... G09F 13/0413  
40/574  
2,985,316 A 5/1961 Ruhnke  
3,323,655 A 6/1967 Foran et al.  
D219,946 S 2/1971 Birnberg  
3,722,702 A 3/1973 Marker, Jr.

(Continued)

OTHER PUBLICATIONS

RFID Technology [online], [retrieved Feb. 14, 2013]. Retrieved  
from the Internet: <URL: [http://www.vorelco.com/services/rfid-  
technology](http://www.vorelco.com/services/rfid-technology)>, 16 pages.

(Continued)

*Primary Examiner* — Mary Ann Calabrese

(74) *Attorney, Agent, or Firm* — Bryan Cave LLP

(57) **CLAIM**

The ornamental design for a pair of advertising panels with  
rectangular marker for shopping cart corral, as shown and  
described.

**DESCRIPTION**

FIG. 1 is a perspective view of the pair of advertising panels  
with rectangular marker for shopping cart corral;  
FIG. 2 is a left side view thereof;  
FIG. 3 is a right side view thereof;  
FIG. 4 is a front view thereof;  
FIG. 5 is a rear view thereof;  
FIG. 6 is a top view thereof;  
FIG. 7 is a perspective view of the pair of advertising panels  
with rectangular marker for shopping cart corral;  
FIG. 8 is a left side view thereof;  
FIG. 9 is a right side view thereof;  
FIG. 10 is a front view thereof;  
FIG. 11 is a rear view thereof; and,  
FIG. 12 is a top view thereof.

The broken line showings of the shopping cart corral in the  
figures are for the purpose of illustrating an environment  
only and form no part of the claimed design.

**1 Claim, 10 Drawing Sheets**

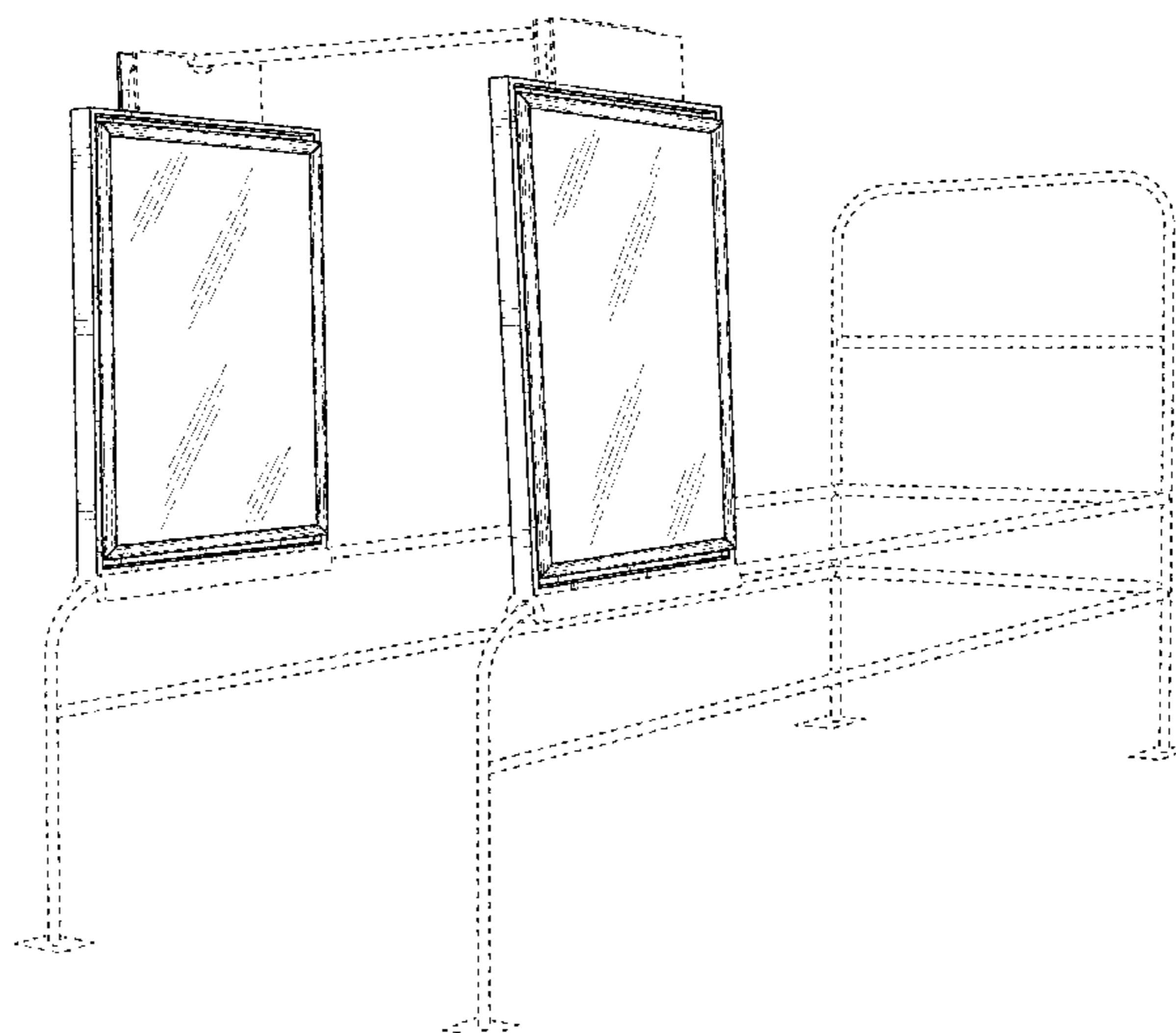

(56)

References Cited

U.S. PATENT DOCUMENTS

3,744,168 A \* 7/1973 Howe ..... G09F 11/00  
40/572

4,236,697 A 12/1980 Savino

4,292,352 A 9/1981 Singer

4,333,253 A \* 6/1982 Cooper ..... G09F 15/0012  
40/584

4,364,192 A 12/1982 Lloyd

D269,978 S 8/1983 Dickson

4,609,183 A 9/1986 Ulmer

D286,074 S 10/1986 Corte

4,777,750 A 10/1988 Garfinkle

4,884,353 A 12/1989 Taylor

4,918,878 A 4/1990 Paschke et al.

4,957,256 A 9/1990 Boeding

D317,671 S \* 6/1991 Skaggs ..... D99/34

D321,798 S 11/1991 Buckley

5,082,087 A 1/1992 Hubbell

D334,301 S 3/1993 Buckley

5,201,426 A 4/1993 Cruwell

5,220,740 A 6/1993 Brault

5,279,085 A 1/1994 DiPaolo et al.

D350,038 S 8/1994 Buckley

D361,448 S 8/1995 Buckley

5,551,578 A 9/1996 McCue et al.

D376,854 S 12/1996 DiPaolo et al.

5,626,926 A 5/1997 Roberts

5,708,782 A 1/1998 Larson et al.

5,862,921 A 1/1999 Venegas

D405,473 S \* 2/1999 Tikhonski ..... D20/10

5,875,578 A 3/1999 Grewe

5,878,518 A 3/1999 Grewe

D430,901 S 9/2000 Palmer

6,298,997 B1 10/2001 Jarrett et al.

6,449,888 B1 9/2002 Gibbs

6,493,997 B2 12/2002 Cohen

6,581,616 B1 6/2003 Venegas

D488,904 S 4/2004 Unnerstall et al.

D492,732 S 7/2004 Herbst

D495,011 S 8/2004 Trubiano

D497,167 S 10/2004 Ozolins et al.

6,975,205 B1 12/2005 French et al.

7,044,446 B2 5/2006 Hempen et al.

D529,960 S 10/2006 Cox

7,140,581 B1 11/2006 White

D537,952 S 3/2007 Anton

D540,472 S 4/2007 Van Es

7,210,270 B1 5/2007 King et al.

7,237,360 B2 7/2007 Moncho et al.

7,283,650 B1 10/2007 Sharma et al.

D587,761 S 3/2009 Grimshaw

D588,201 S 3/2009 Kohagen et al.

7,660,747 B2 2/2010 Brice et al.

D613,338 S \* 4/2010 Marukos ..... D20/10

D615,129 S 5/2010 Allen

D620,531 S 7/2010 Allen

7,894,936 B2 2/2011 Walker et al.

7,895,782 B2 3/2011 Farrell

8,015,737 B2 9/2011 Venegas, Jr.

8,104,671 B2 1/2012 Besecker et al.

D653,709 S 2/2012 Allen

RE43,233 E 3/2012 Venegas, Jr.

8,196,326 B2 6/2012 Frey

8,205,757 B2 6/2012 Allen

D663,779 S 7/2012 Lueken

RE43,634 E \* 9/2012 Mischel, Jr. .... D14/371

D667,504 S 9/2012 Allen

D670,343 S \* 11/2012 Byford ..... D20/43

8,332,272 B2 12/2012 Fisher

8,424,690 B2 4/2013 Allen

D682,944 S 5/2013 Lueken

D695,835 S 12/2013 Lueken

D695,836 S 12/2013 Lueken

D695,837 S 12/2013 Lueken

D699,789 S 2/2014 Allen

D701,322 S 3/2014 McCue et al.

D703,271 S 4/2014 Lueken

D725,287 S 3/2015 Allen

8,984,782 B1 3/2015 Lueken

8,998,003 B2 4/2015 McCue et al.

9,138,081 B1 9/2015 Allen

9,301,627 B1 4/2016 Lueken

9,301,628 B1 4/2016 Allen

D756,461 S 5/2016 Lueken

9,367,859 B2 6/2016 Lueken

2003/0115096 A1 6/2003 Reynolds et al.

2004/0079934 A1 4/2004 Hempen et al.

2004/0225560 A1 11/2004 Lewis et al.

2005/0083465 A1 4/2005 Niiyama et al.

2008/0040962 A1 2/2008 Gurren

2008/0120877 A1 5/2008 Farrell

2008/0185888 A1 8/2008 Beall et al.

2008/0262928 A1 10/2008 Michaelis

2009/0288012 A1 11/2009 Hertel et al.

2010/0114683 A1 5/2010 Wessels et al.

2010/0327245 A1 12/2010 Allen

2011/0047023 A1 2/2011 Lieblang et al.

2011/0185607 A1 8/2011 Forster et al.

2011/0218942 A1 9/2011 Scheffer

2012/0029998 A1 2/2012 Aversano et al.

2012/0066068 A1 3/2012 Pan

2012/0123826 A1 5/2012 French et al.

2012/0209686 A1 8/2012 Horowitz et al.

2012/0271715 A1 10/2012 Morton et al.

2013/0085835 A1 4/2013 Horowitz

2013/0090999 A1 4/2013 Lellouche

2013/0091002 A1 4/2013 Christie et al.

2013/0159090 A1 6/2013 Boal

2013/0204697 A1 8/2013 Boal

2013/0332253 A1 12/2013 Shiffert et al.

2013/0332258 A1 12/2013 Shiffert et al.

2013/0332274 A1 12/2013 Faith et al.

2013/0332283 A1 12/2013 Faith et al.

2014/0108108 A1 4/2014 Artman et al.

FOREIGN PATENT DOCUMENTS

EP 2273444 1/2011

EP 2487875 8/2012

WO WO2013/040591 3/2013

WO WO2013/126894 8/2013

OTHER PUBLICATIONS

Thinaire Launches the First Ever NFC Enterprise Marketing Platform [online], Sep. 12, 2012, [retrieved Jul. 31, 2014]. Retrieved from the Internet <URL: <http://globenewswire.com/news-release/2012/09/12/490308/10004878/en/Thinaire-TM-Launches-the-First-Ever-NFC-Enterprise-Marketing-Platform.html>>.

Kraft NFC pilot delivers 12 times the engagement level of QR codes [online], Oct. 18, 2012, [retrieved Jul. 31, 2014]. Retrieved from the Internet <URL: <http://www.mobilecommercedaily.com/kraft-nfc-pilot-delivers-12-times-the-engagement-level-of-qr-codes>>.

Valassis Launches Electronic Coupon Clearing Platform [online], Oct. 20, 2011, [retrieved Jul. 31, 2014]. Retrieved from the Internet <URL: <http://news.thomasnet.com/fullstory/Coupon-Redemption-Software-performs-real-time-validation-604347>>.

RFID-Enabled Cart Set to Provide Shoppers With Product Info, Ads [online], Jan. 31, 2007, [retrieved Jul. 31, 2014]. Retrieved from the Internet <URL: <http://rfidjournal.com/articles/view?3013>>.

Meijer's Smart Carts [online], Nov. 8, 2006, [retrieved Jul. 31, 2014]. Retrieved from the Internet <URL: <http://www.retailwire.com/discussion/11786/meijers-smart-carts>>.

Store logistics and payment with NFC [online], Jul. 1, 2006, [retrieved Jul. 31, 2014]. Retrieved from the Internet <URL: <http://www.ist-world.org/ProjectDetails.aspx?ProjectId=e89323fb585a4b798bf211f044c71b54&SourceDatabaseId=7cff9226e582440894200b751bab883f>>.

Brand.net brochure, Mobile Ads: Any Device / Instant Action.

(56)

**References Cited**

OTHER PUBLICATIONS

Stop and Shop, Login [online], [retrieved Aug. 1, 2014]. Retrieved from the Internet <URL: [https://www.stopandshop.com/login/?\\_requestid=88655](https://www.stopandshop.com/login/?_requestid=88655)>.

Grabert, Clear Channel Outdoor launches 'Connect,' the first global out-of-home mobile interactive.

\* cited by examiner

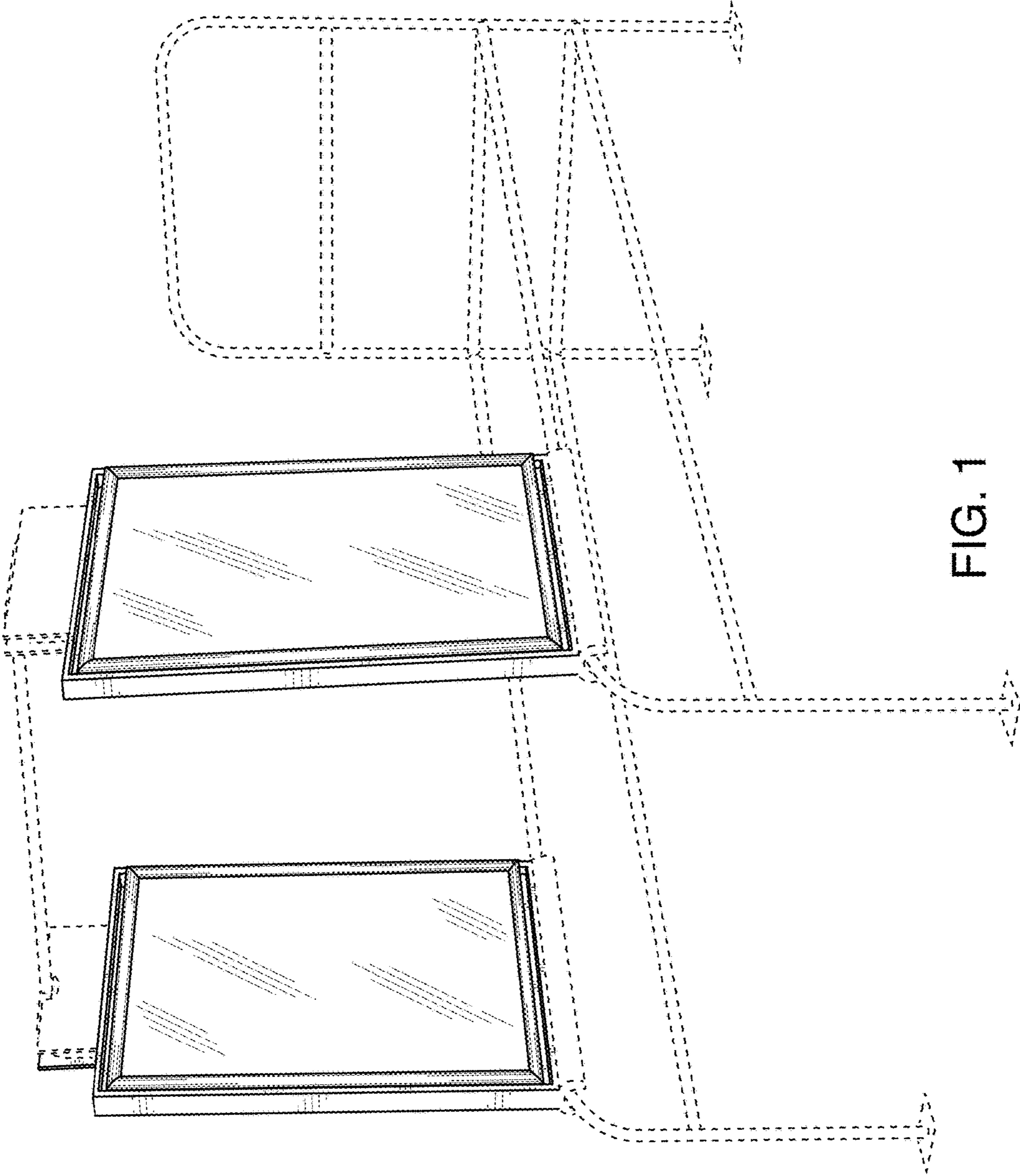

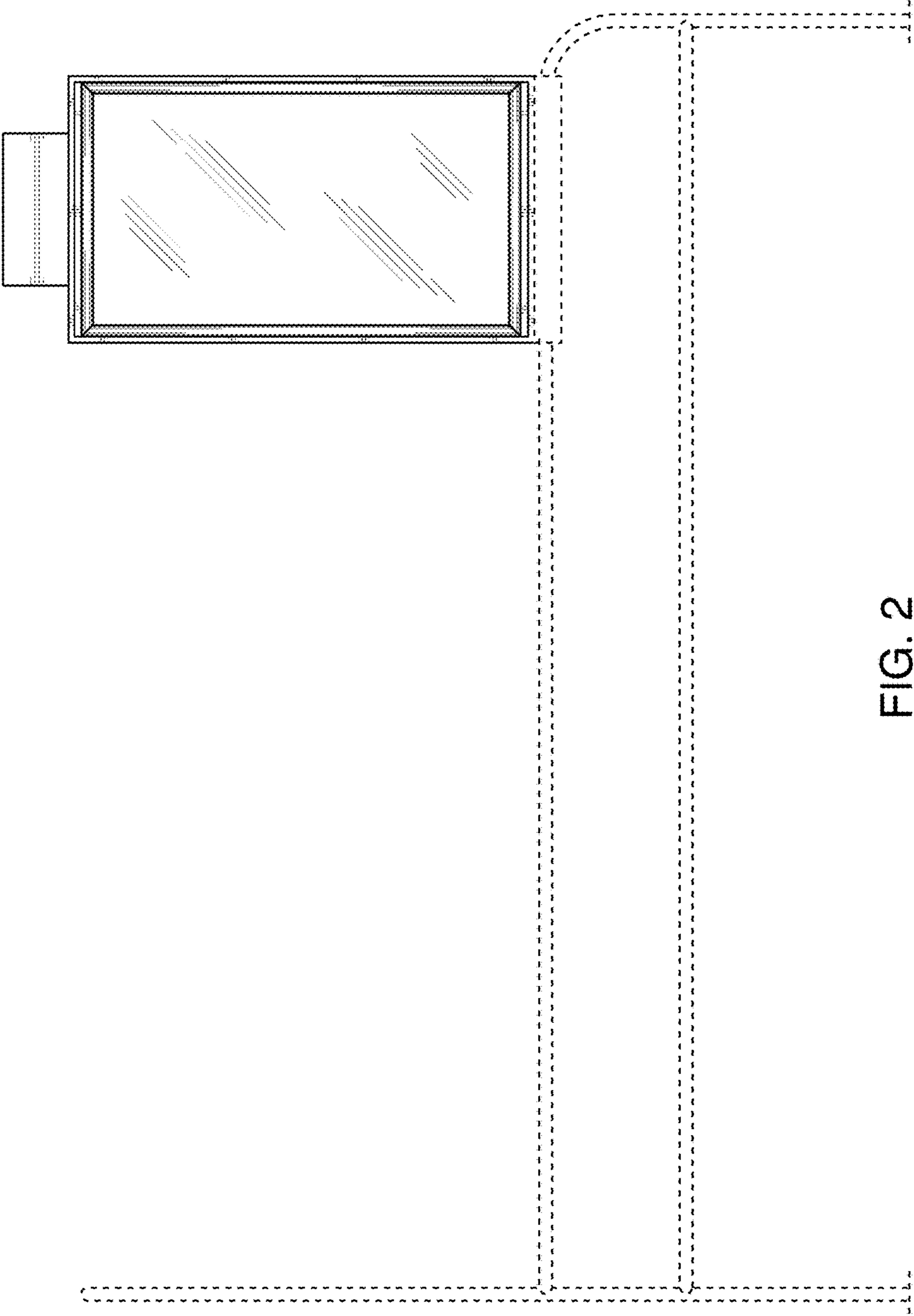

FIG. 2

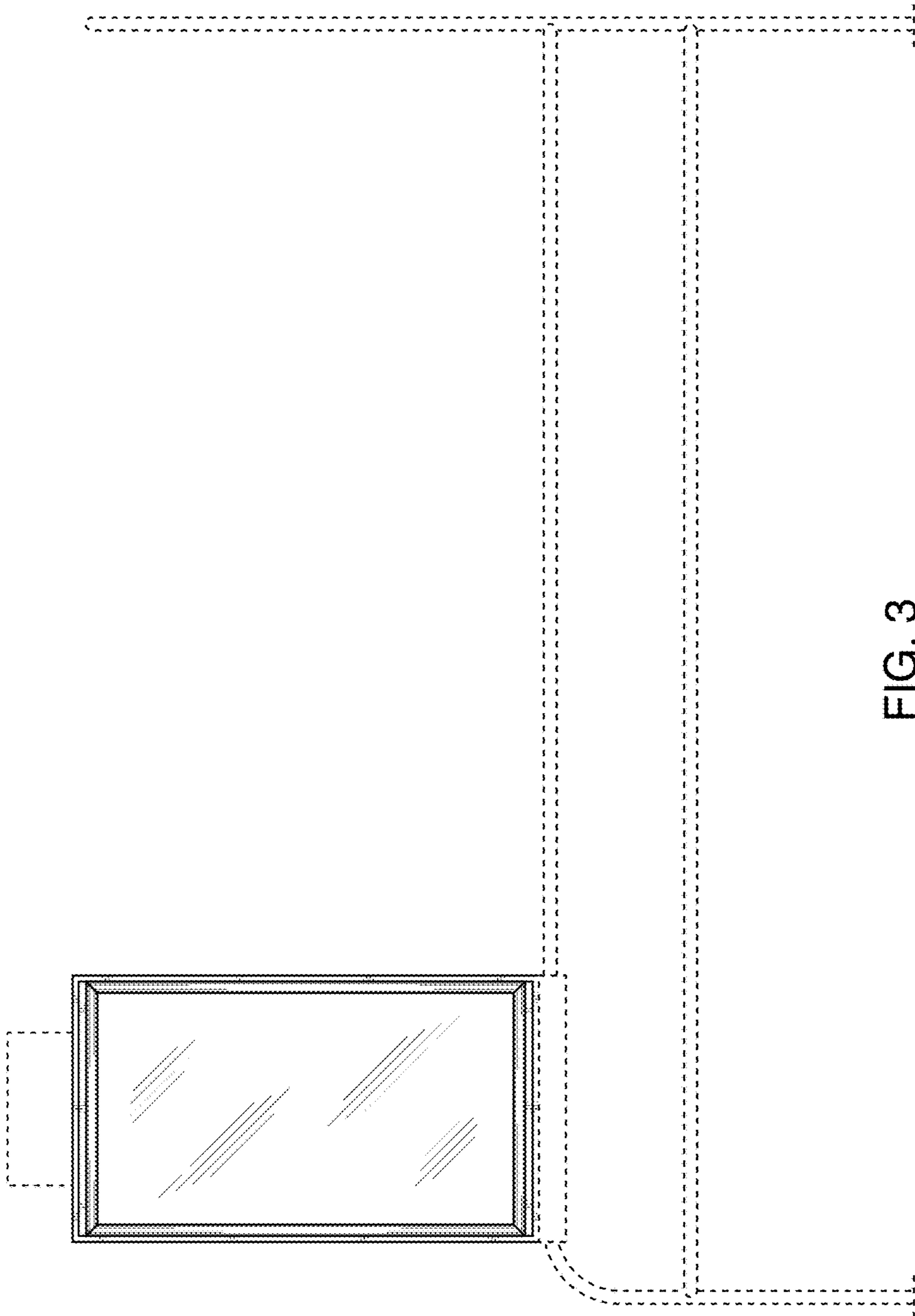

FIG. 3

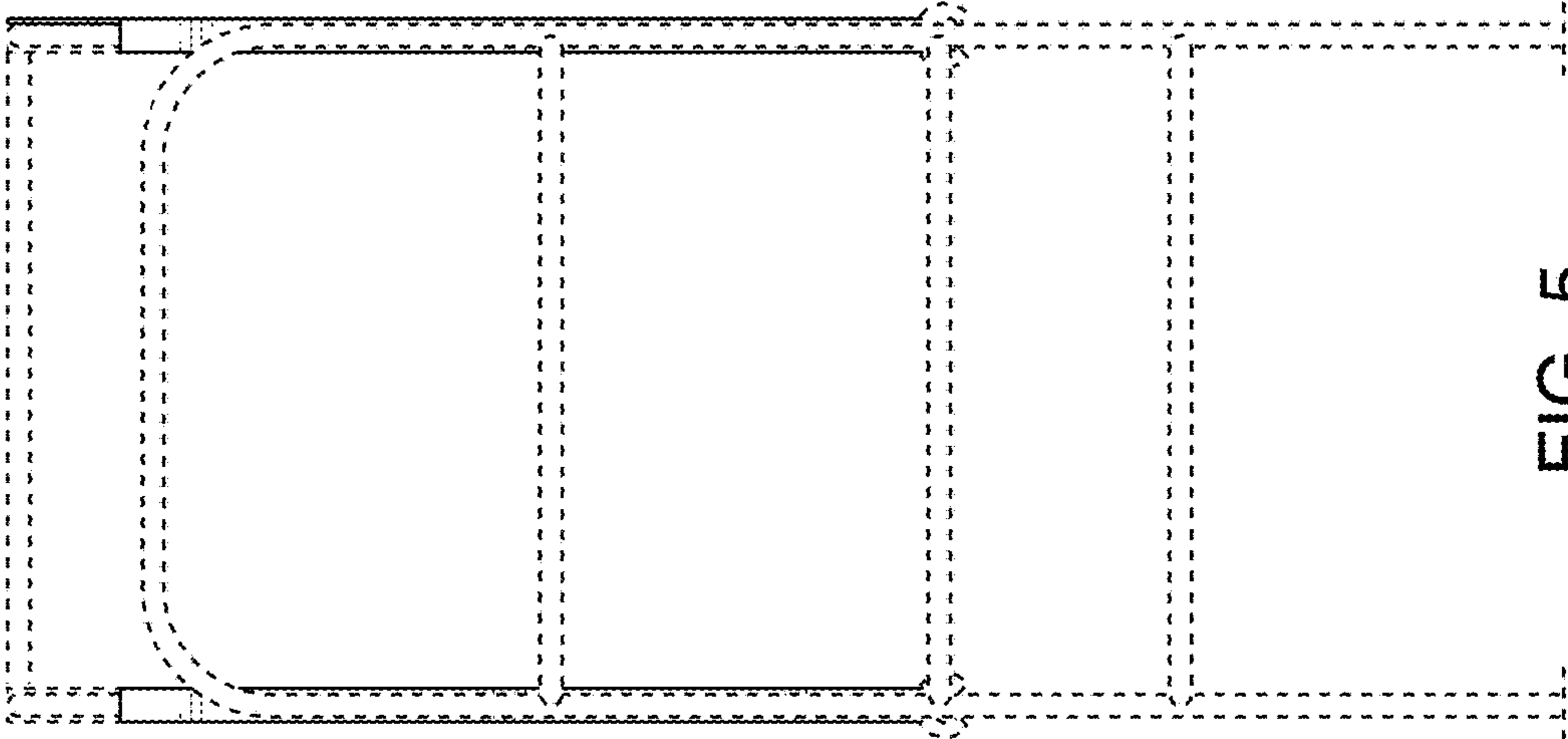

FIG. 5

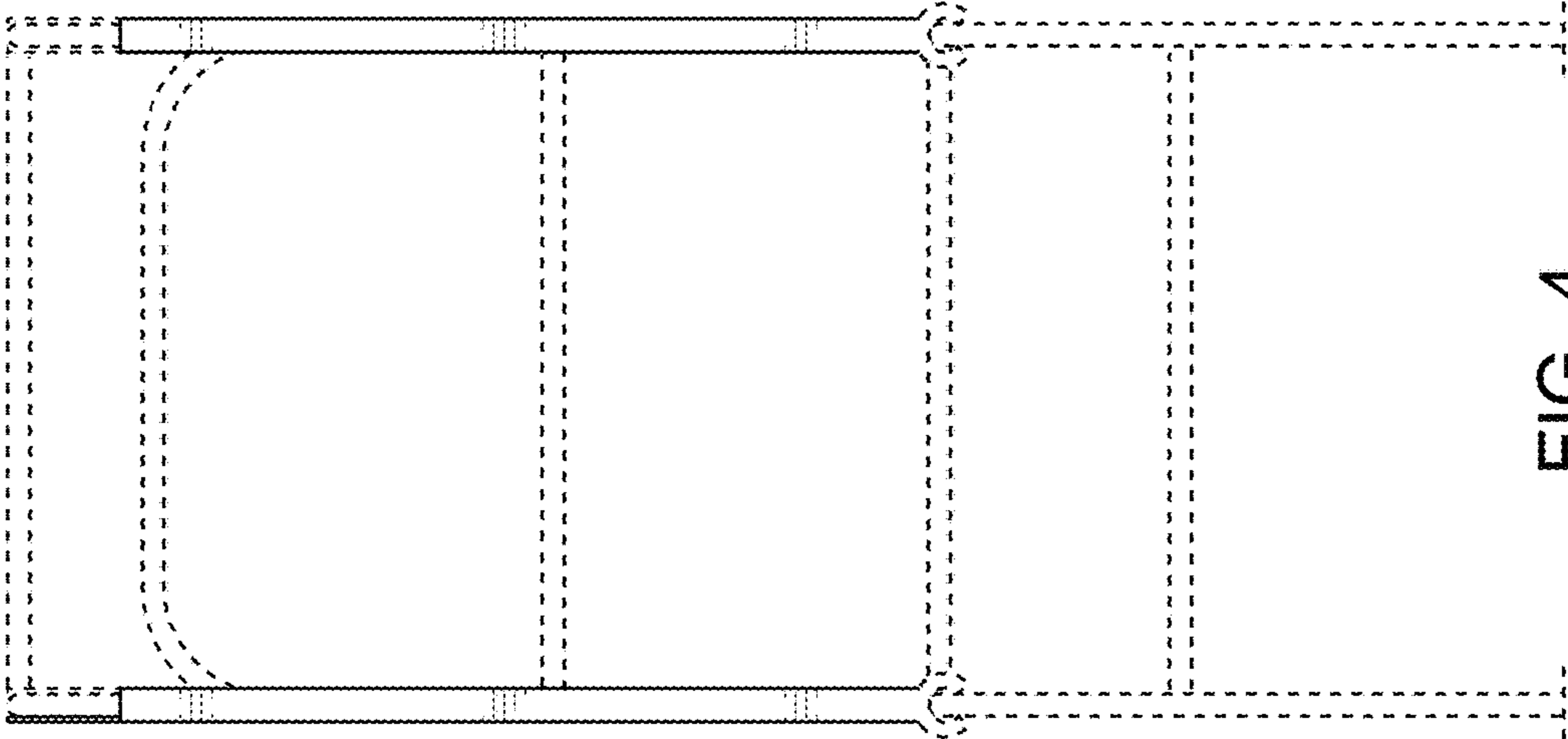

FIG. 4

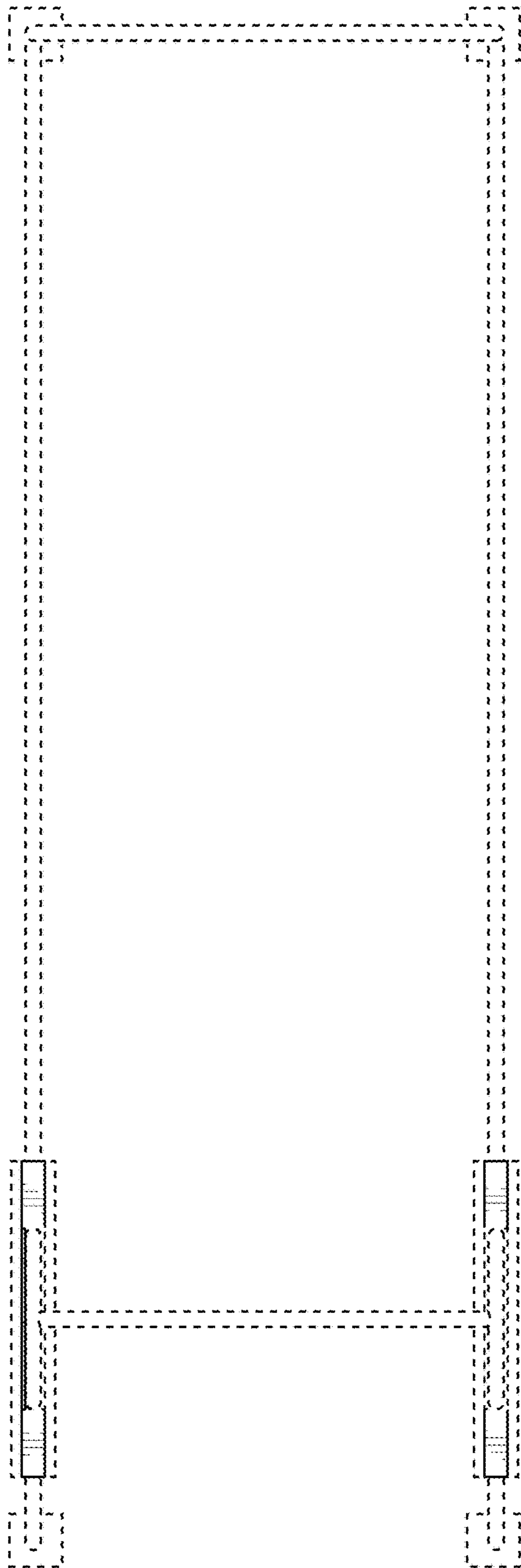

FIG. 6



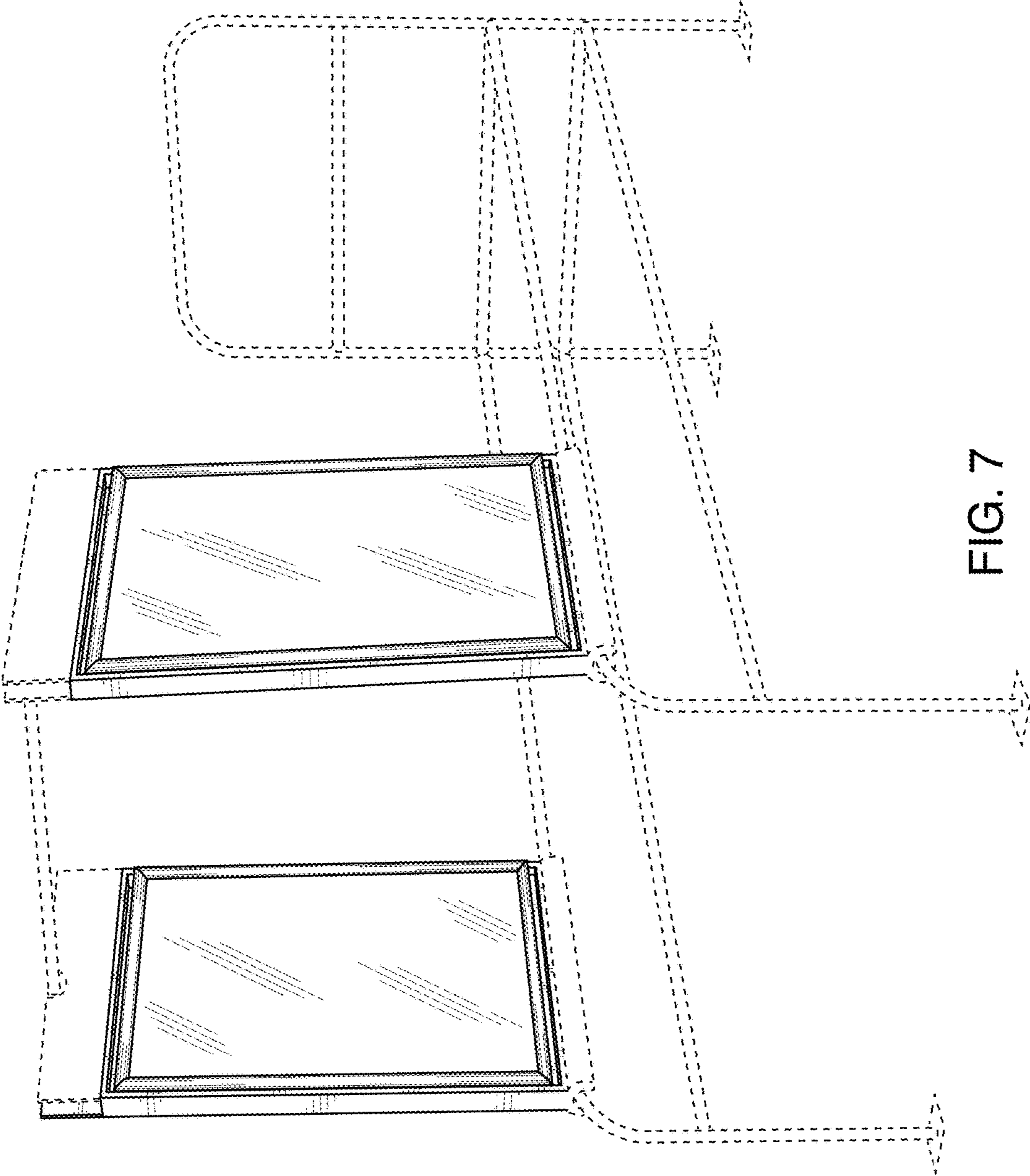

FIG. 7

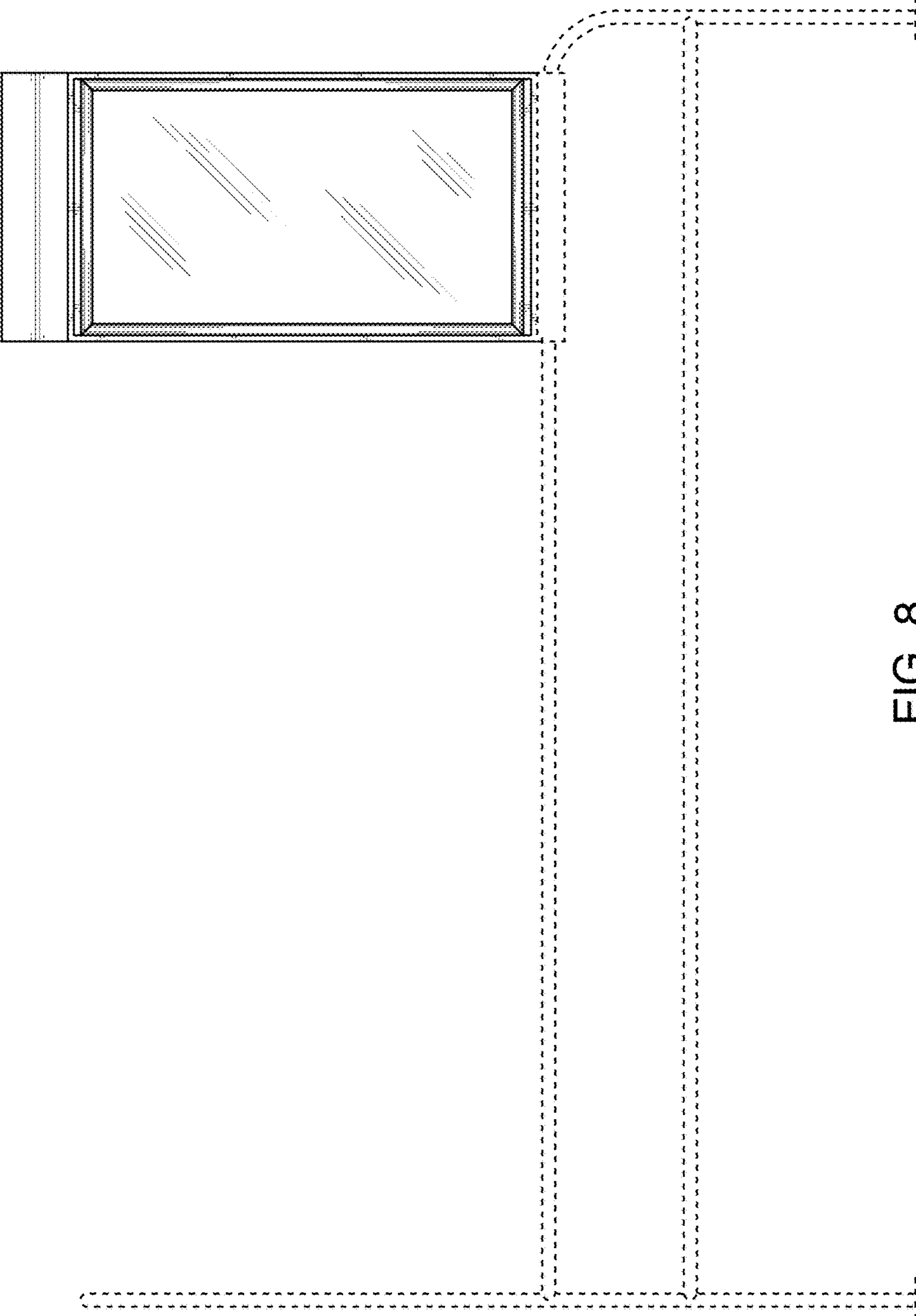

FIG. 8

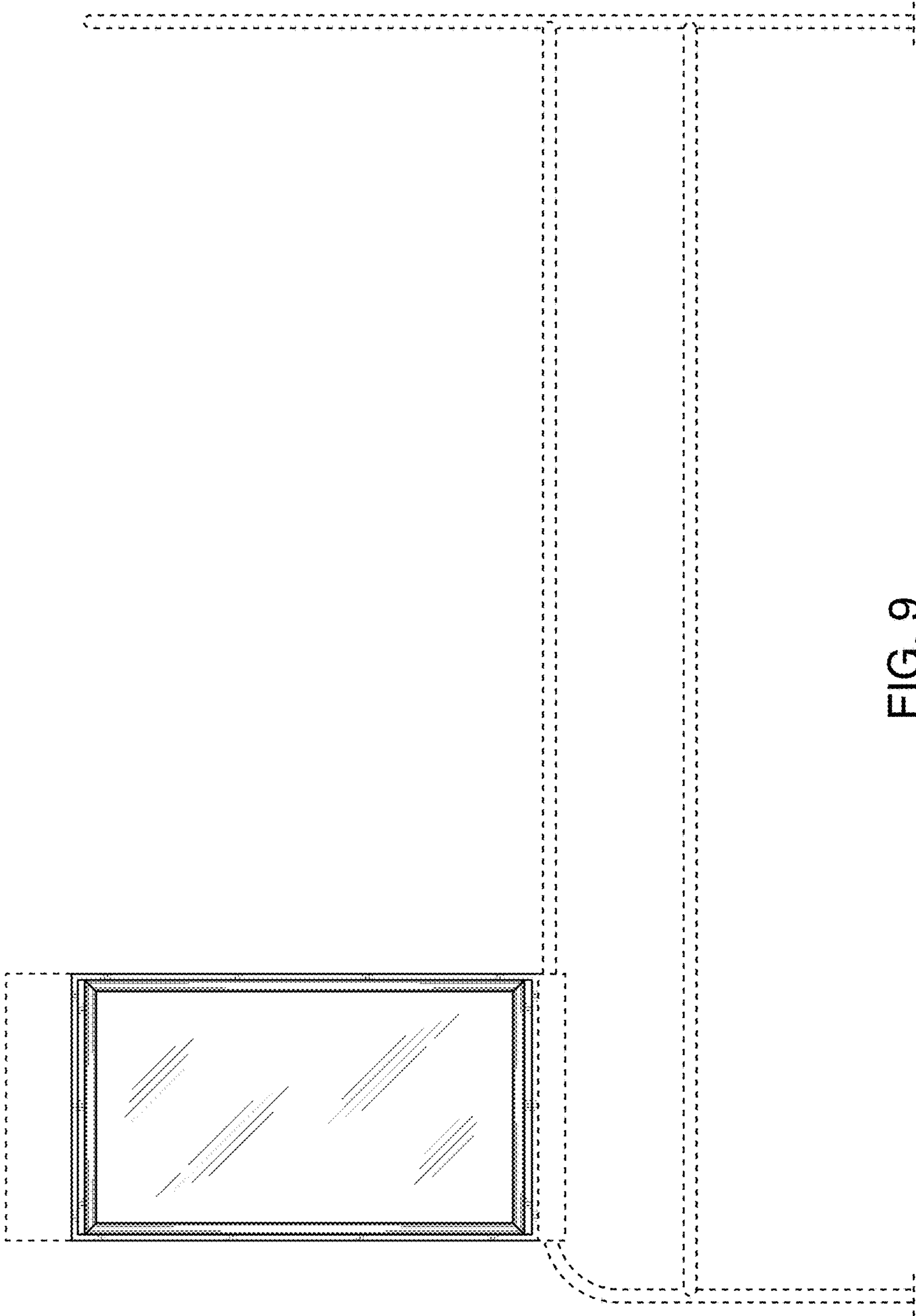

FIG. 9

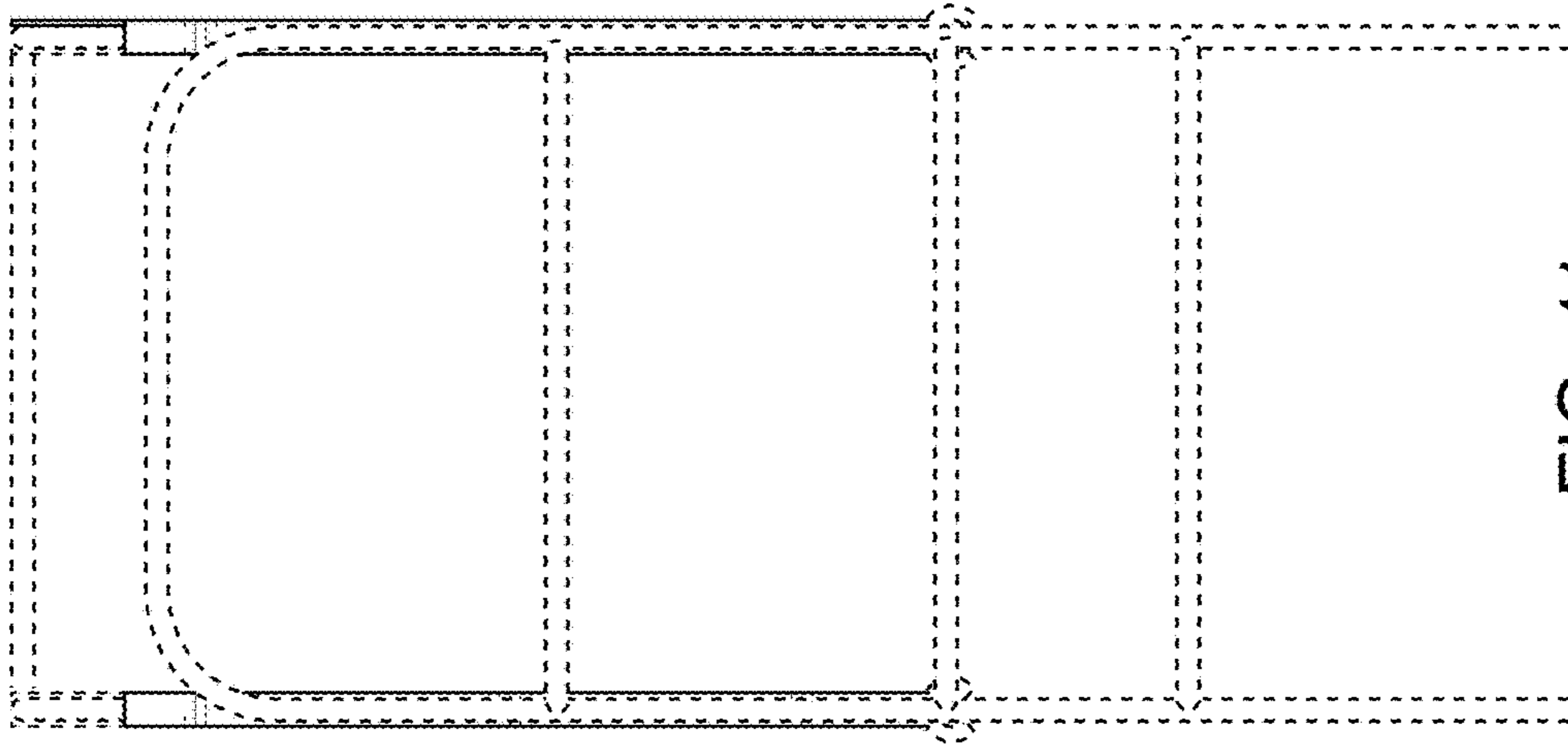

FIG. 11

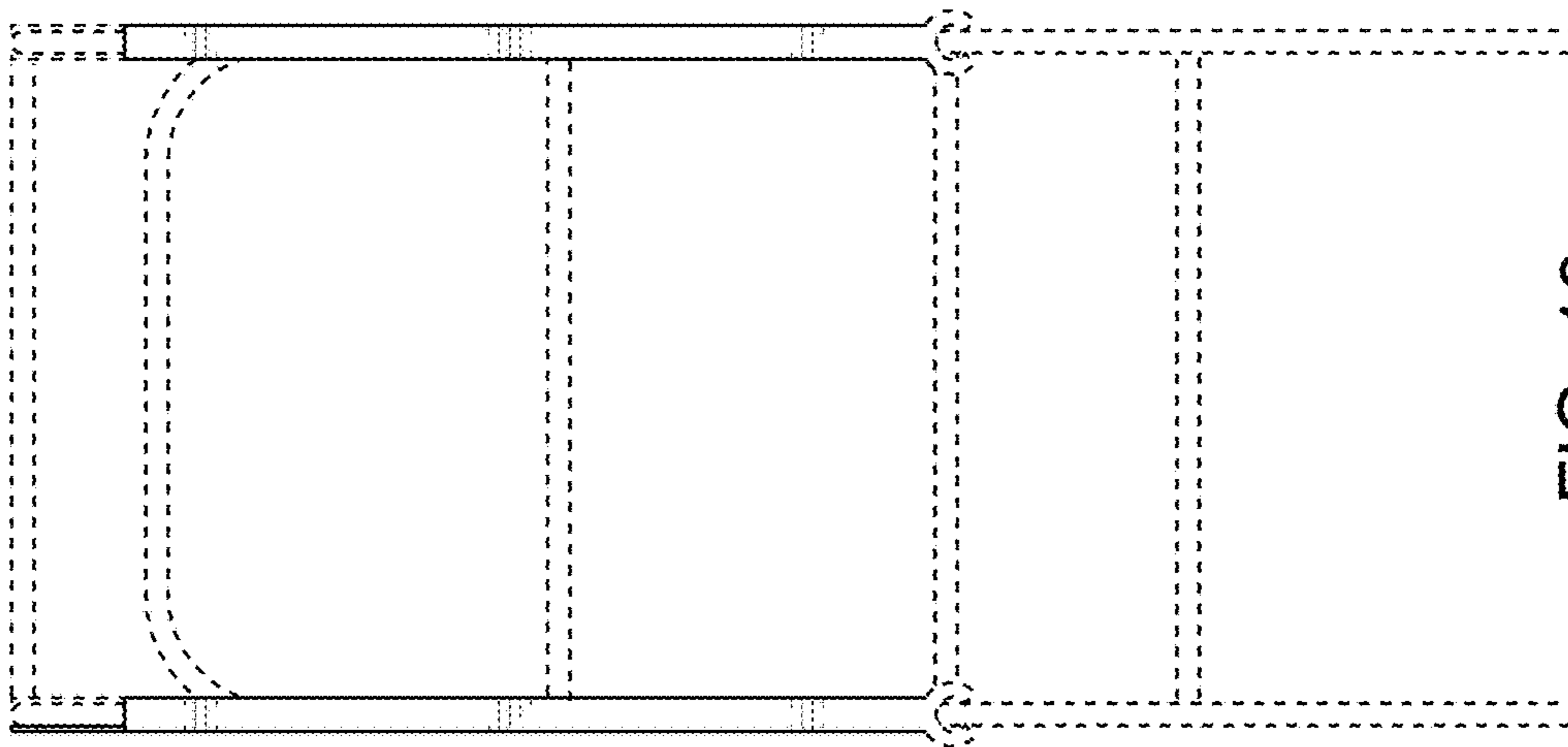

FIG. 10

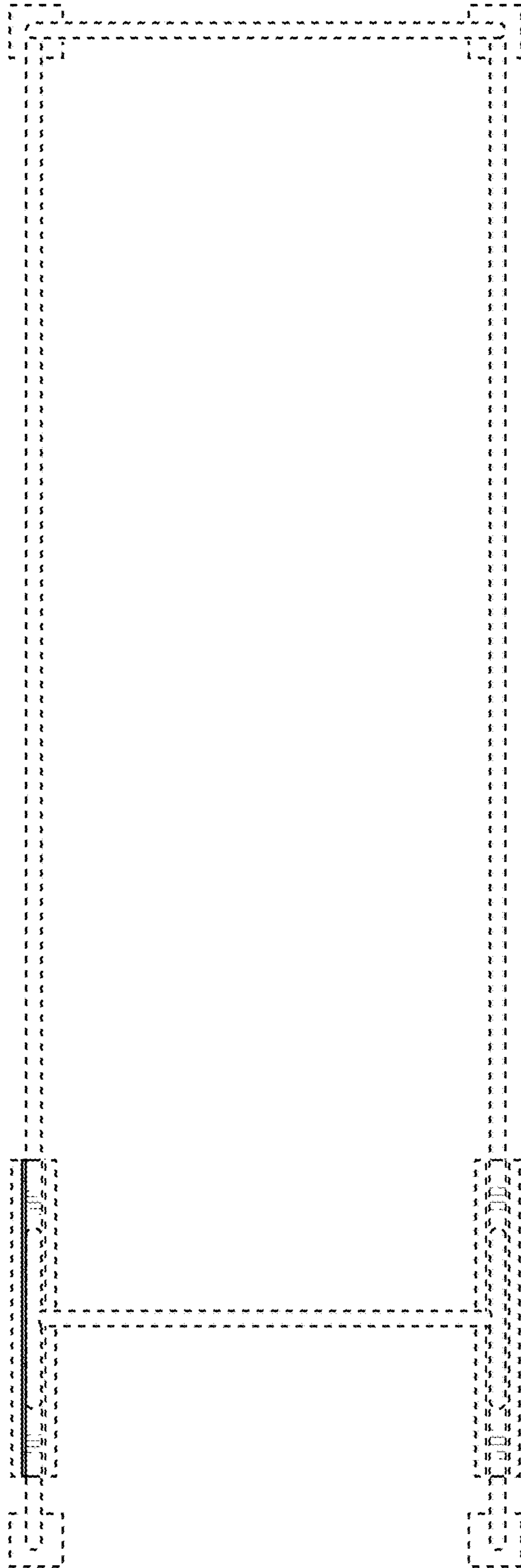

FIG. 12