



US00D788195S

(12) **United States Design Patent** (10) **Patent No.:** **US D788,195 S**  
**Liu et al.** (45) **Date of Patent:** **\*\* May 30, 2017**

(54) **FILAMENT CARTRIDGE FOR 3D PRINTING**

(71) Applicant: **PRINT-RITE • UNICORN IMAGE PRODUCTS CO., LTD. OF ZHUHAI, Zhuhai (CN)**

(72) Inventors: **Li'an Liu, Zhuhai (CN); Daoquan Song, Zhuhai (CN); Kin Keung So, Zhuhai (CN)**

(73) Assignee: **PRINT-RITE • UNICORN IMAGE PRODUCTS CO., LTD. OF ZHUHAI (CN)**

(\*\*) Term: **14 Years**

(21) Appl. No.: **29/514,689**

(22) Filed: **Jan. 15, 2015**

(30) **Foreign Application Priority Data**

Jul. 16, 2014 (CN) ..... 2014 3 0239779

(51) **LOC (10) Cl.** ..... **15-09**

(52) **U.S. Cl.**  
USPC ..... **D15/122; D18/56**

(58) **Field of Classification Search**  
USPC ..... D15/122; D14/475; D18/43, 50, 56;  
347/86

CPC ..... B33Y 40/00; B33Y 33/00; B41J 2/1752;  
B41J 2/17553

See application file for complete search history.

(56) **References Cited**

**U.S. PATENT DOCUMENTS**

4,114,832 A \* 9/1978 Tauscher ..... G11B 23/093  
242/338.2  
D436,111 S \* 1/2001 Hahn ..... D14/475

D501,011 S \* 1/2005 Sumner ..... D14/480  
D531,213 S \* 10/2006 Hegge ..... 347/86  
D650,787 S \* 12/2011 Taatjes ..... D14/475  
D680,164 S \* 4/2013 Kawate ..... D18/56  
D704,259 S \* 5/2014 Lecheheb ..... D18/56  
D737,347 S \* 8/2015 Anantha ..... D14/475  
D744,586 S \* 12/2015 Chung ..... D15/122  
D747,374 S \* 1/2016 Anantha ..... D14/475  
D748,193 S \* 1/2016 Chung ..... D15/122  
2007/0001050 A1 \* 1/2007 Taatjes ..... B33Y 40/00  
242/598.6  
2014/0300671 A1 \* 10/2014 Nie ..... B41J 2/17553  
347/86

\* cited by examiner

*Primary Examiner* — Susan Bennett Hattan

*Assistant Examiner* — Brett Miller

(74) *Attorney, Agent, or Firm* — Lerner, David, Littenberg, Krumholz & Mentlik, LLP

(57) **CLAIM**

The ornamental designs for a filament cartridge for 3D printing, as shown and described.

**DESCRIPTION**

FIG. 1 is a perspective view of a filament cartridge for 3D printing in accordance with our new design;  
FIG. 2 is a front elevational view thereof;  
FIG. 3 is a bottom plan view thereof;  
FIG. 4 is a top plan view thereof;  
FIG. 5 is a rear elevational view thereof;  
FIG. 6 is a left side view thereof; and,  
FIG. 7 is a right side view thereof.

**1 Claim, 4 Drawing Sheets**

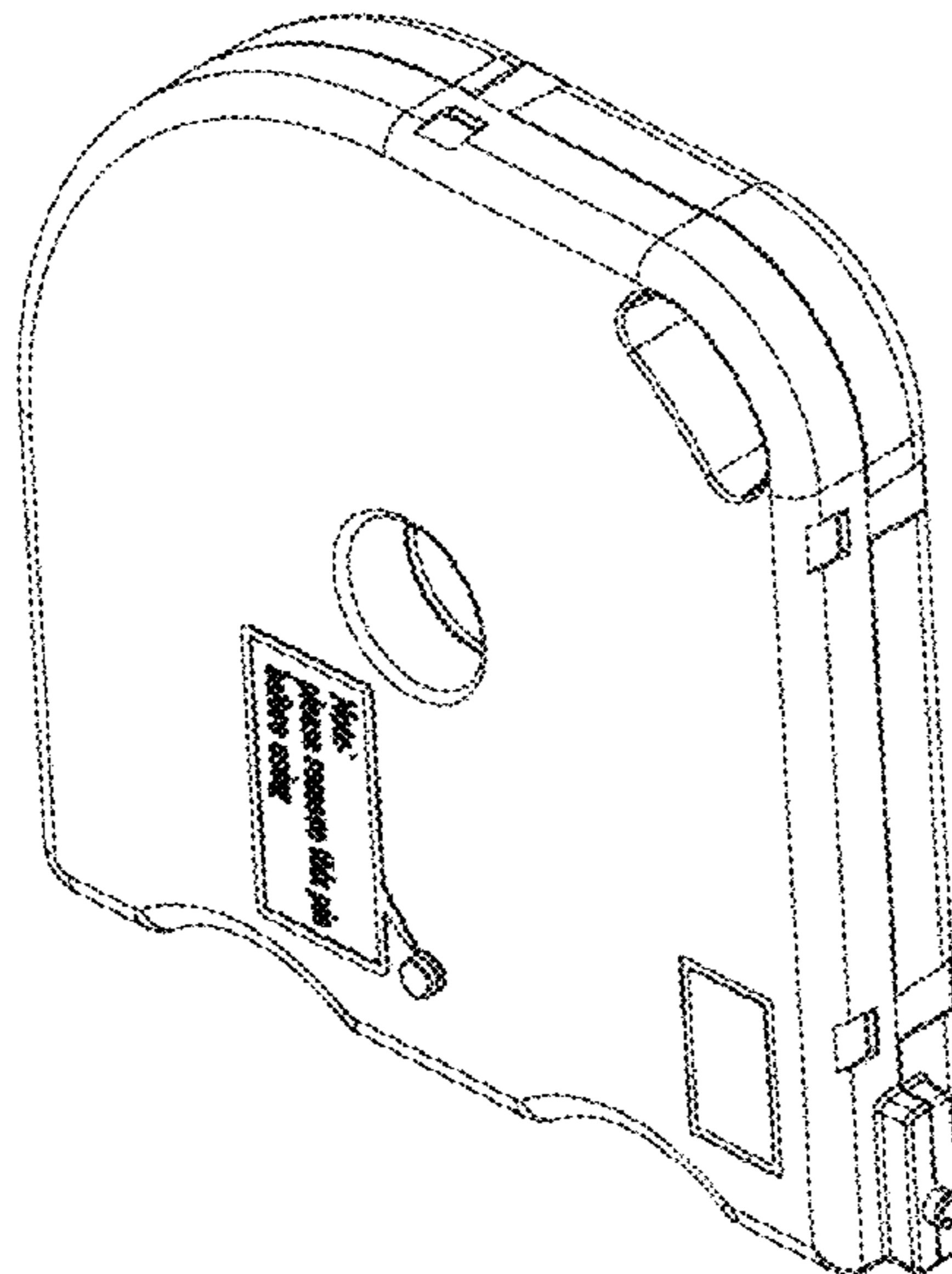

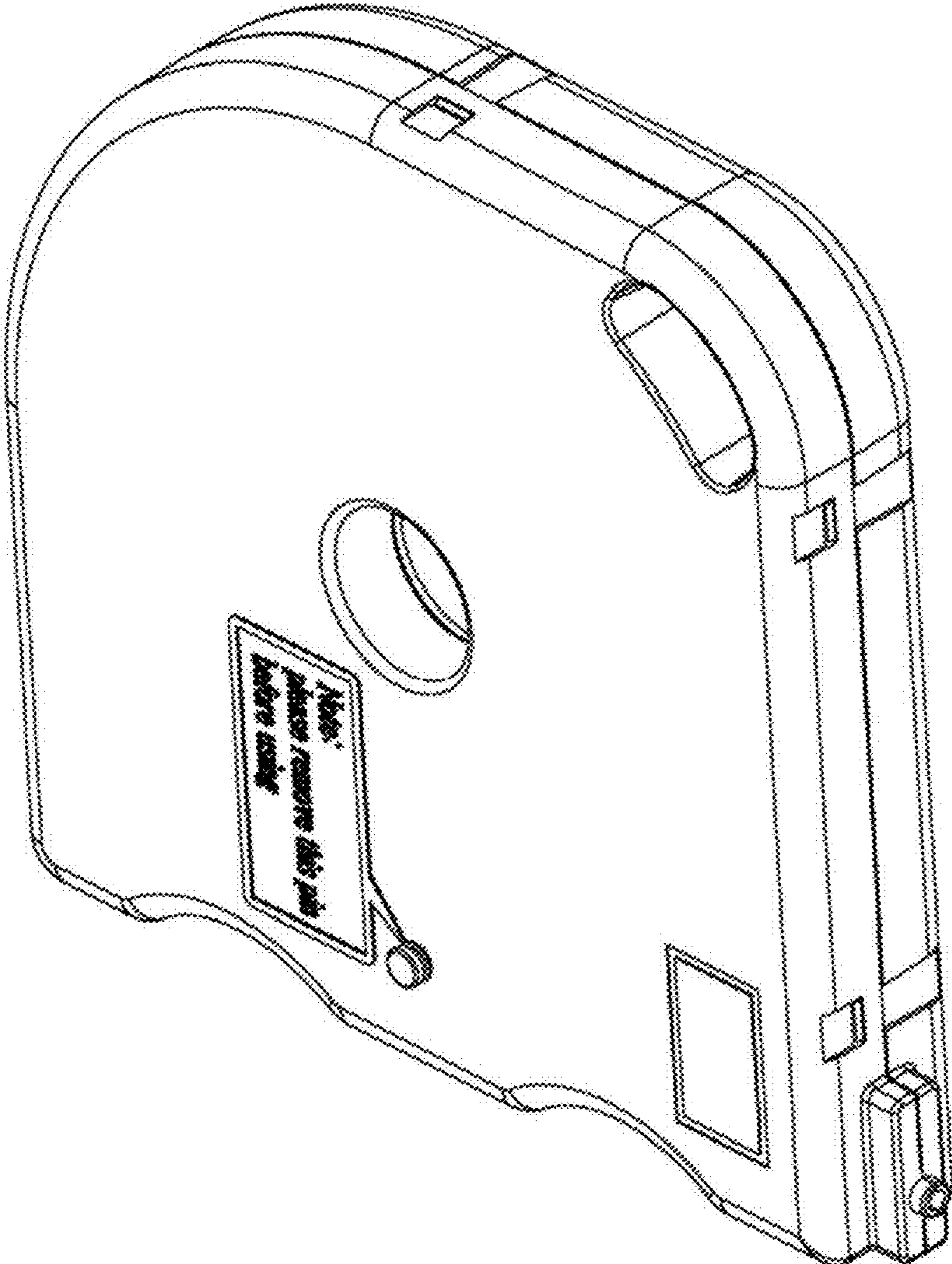

FIG. 1

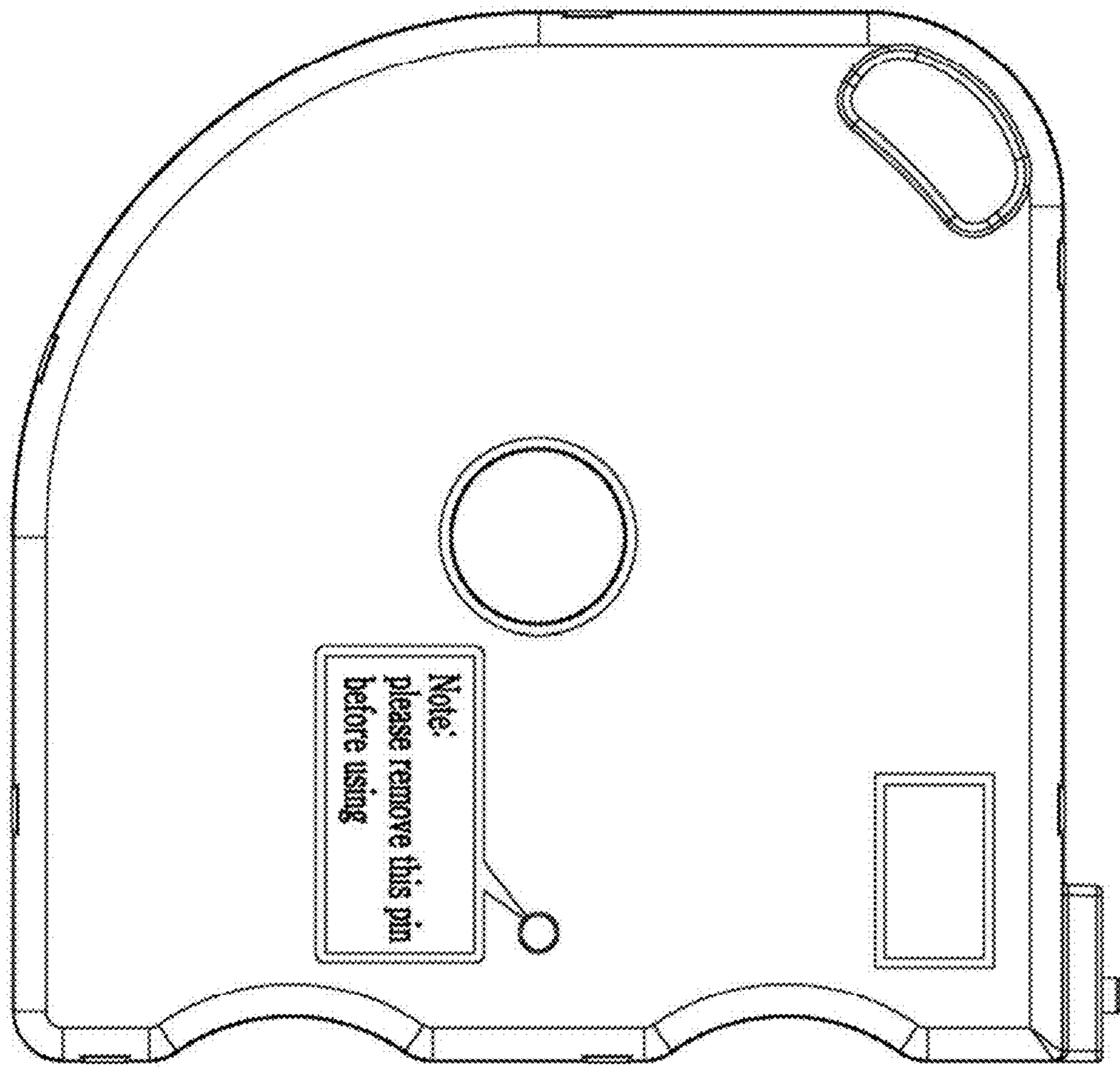

FIG. 2

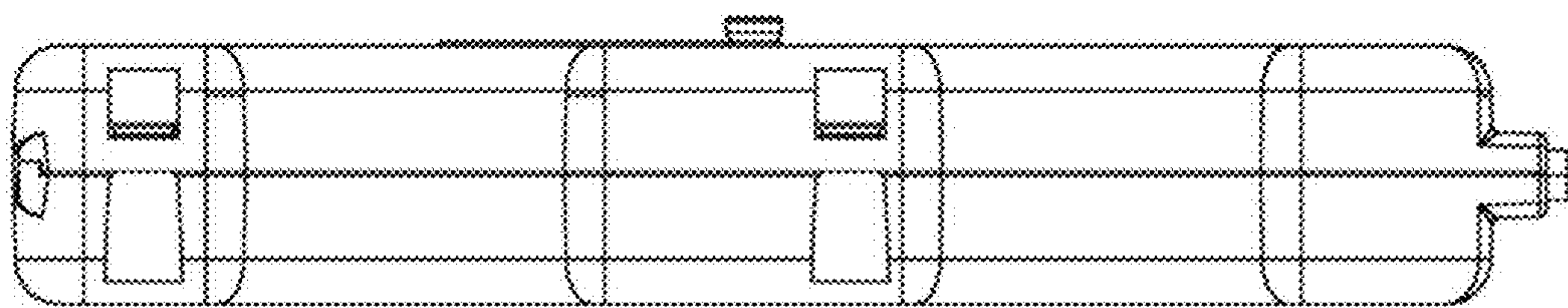

FIG. 3

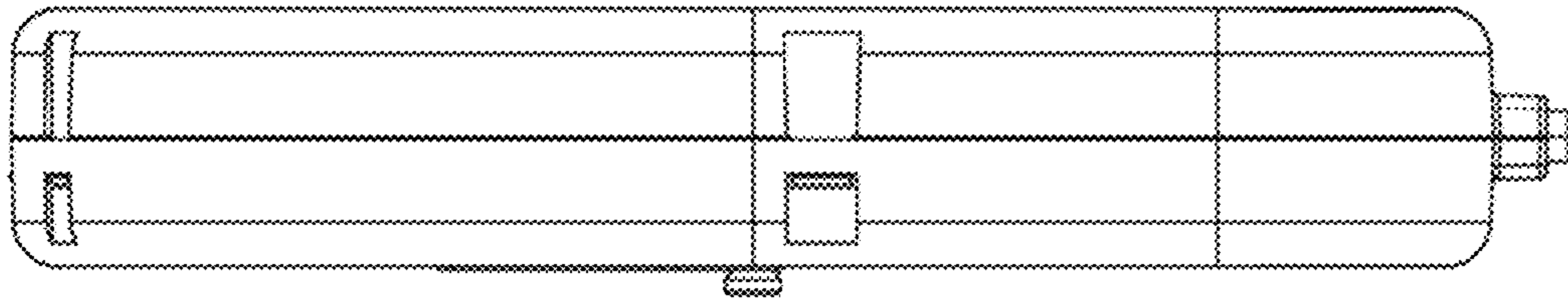

FIG. 4

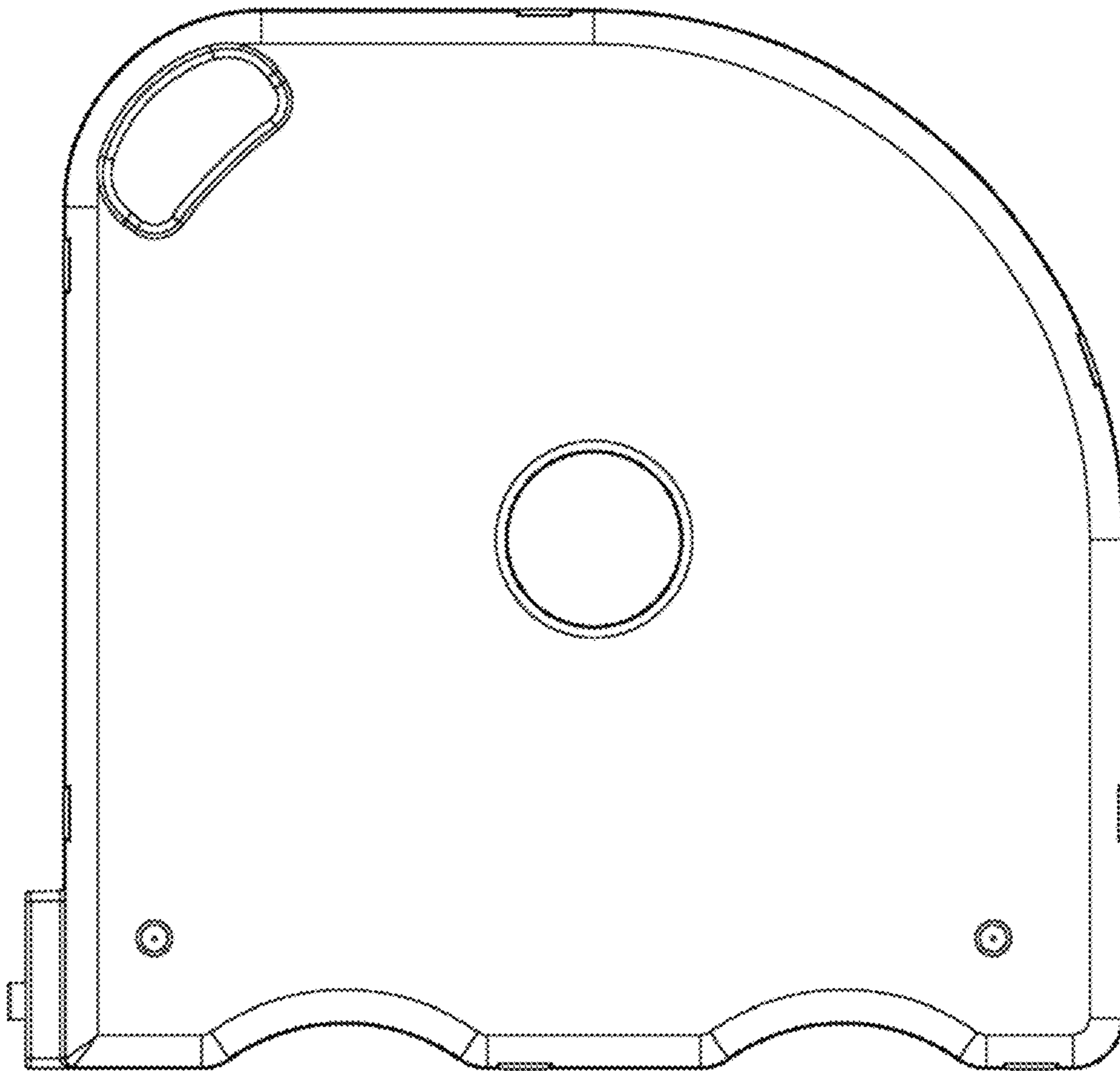

FIG. 5

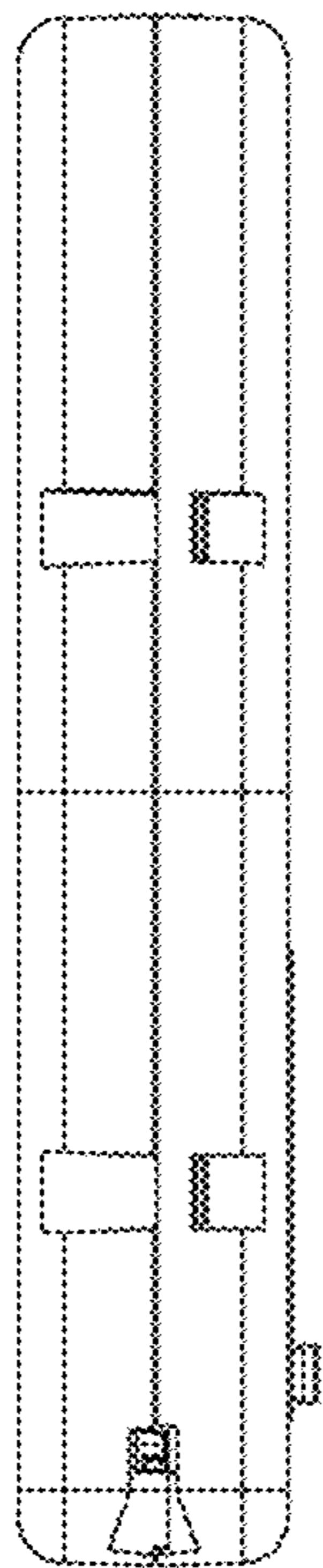

FIG. 6

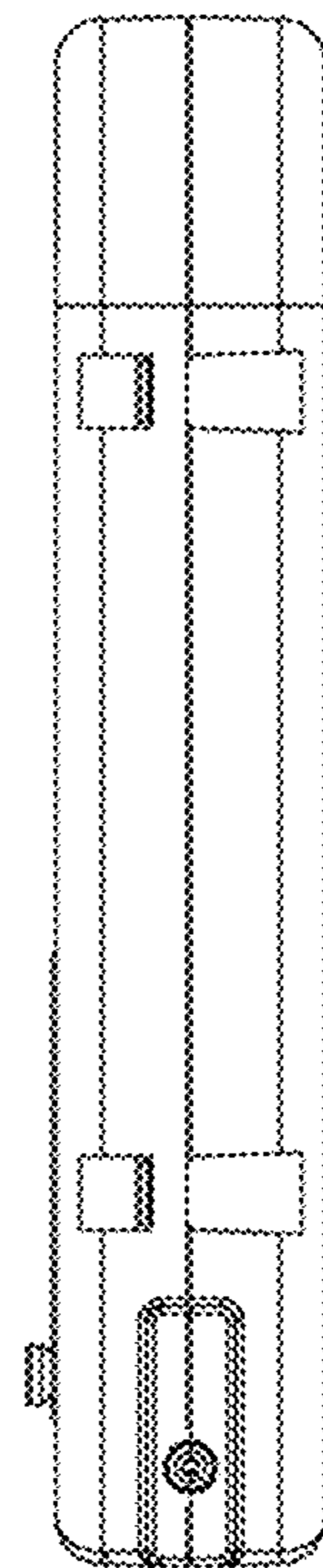

FIG. 7