



US00D787990S

(12) **United States Design Patent** (10) **Patent No.:** **US D787,990 S**
Kozub et al. (45) **Date of Patent:** **** May 30, 2017**

(54) **VEHICLE FRONT FASCIA**
(71) Applicant: **GM GLOBAL TECHNOLOGY OPERATIONS LLC**, Detroit, MI (US)
(72) Inventors: **Timothy P. Kozub**, Troy, MI (US); **Stuart Cooper**, Bloomfield Hills, MI (US); **Jonghyuk Park**, Troy, MI (US)
(73) Assignee: **GM Global Technology Operations LLC**, Detroit, MI (US)

D608,249 S 1/2010 Peters
D608,690 S 1/2010 Folden et al.
D608,691 S 1/2010 Zak, Jr. et al.
D609,608 S 2/2010 Boniface et al.
D611,387 S 3/2010 Thompson et al.
D611,879 S 3/2010 Kim et al.
D612,297 S 3/2010 Peters et al.
D613,645 S 4/2010 Song et al.
D615,458 S 5/2010 Thompson et al.
D617,700 S * 6/2010 Nishio D12/169
D618,595 S 6/2010 Ware et al.
(Continued)

(**) Term: **15 Years**

OTHER PUBLICATIONS

(21) Appl. No.: **29/543,753**
(22) Filed: **Oct. 28, 2015**
(51) **LOC (10) Cl.** **12-01**
(52) **U.S. Cl.**
USPC **D12/169**
(58) **Field of Classification Search**
USPC D12/86-92, 163-172; 293/102-155;
296/35.2, 193.09, 193.1, 203.02
CPC B60R 19/02; B60R 19/023; B60R 19/18;
B60R 19/24; B60R 19/44; B60R 19/48;
B60R 19/56; B60R 2019/527; B60R
2019/1886
See application file for complete search history.

Pleskot, Kelly. "GM Invests \$174 Million in 2016 Chevrolet Malibu Production." motortrend.com. May 4, 2015. Accessed Aug. 1, 2016. Available online at URL: <http://www.motortrend.com/news/gm-invests-174-million-to-support-2016-chevrolet-malibu-production/>.*

(Continued)

Primary Examiner — Cathron Brooks
Assistant Examiner — Christian P McLean
(74) *Attorney, Agent, or Firm* — Reising Ethington P.C.

(57) **CLAIM**

The ornamental design for a vehicle front fascia, as shown and described.

(56) **References Cited**

DESCRIPTION

U.S. PATENT DOCUMENTS

D570,742 S 6/2008 Takagi et al.
D592,105 S 5/2009 Dean et al.
D597,447 S 8/2009 Folden
D600,595 S 9/2009 Nakamura et al.
D601,925 S 10/2009 O'Donnell
D603,755 S 11/2009 Peters
D604,203 S 11/2009 O'Donnell
D605,082 S 12/2009 Munson
D605,083 S 12/2009 Manoogian, II et al.
D605,977 S 12/2009 Zipfel et al.
D605,978 S 12/2009 Wolff et al.

FIG. 1 is a perspective view of the vehicle front fascia; FIG. 2 is a front view thereof; FIG. 3 is left side elevation view thereof (where the right side elevation view is omitted since the right side elevation view is identical to the left side elevation view); and, FIG. 4 is a top plan view thereof. The broken lines shown in the drawings depict portions of the vehicle front fascia that form no part of the claimed design.

1 Claim, 2 Drawing Sheets

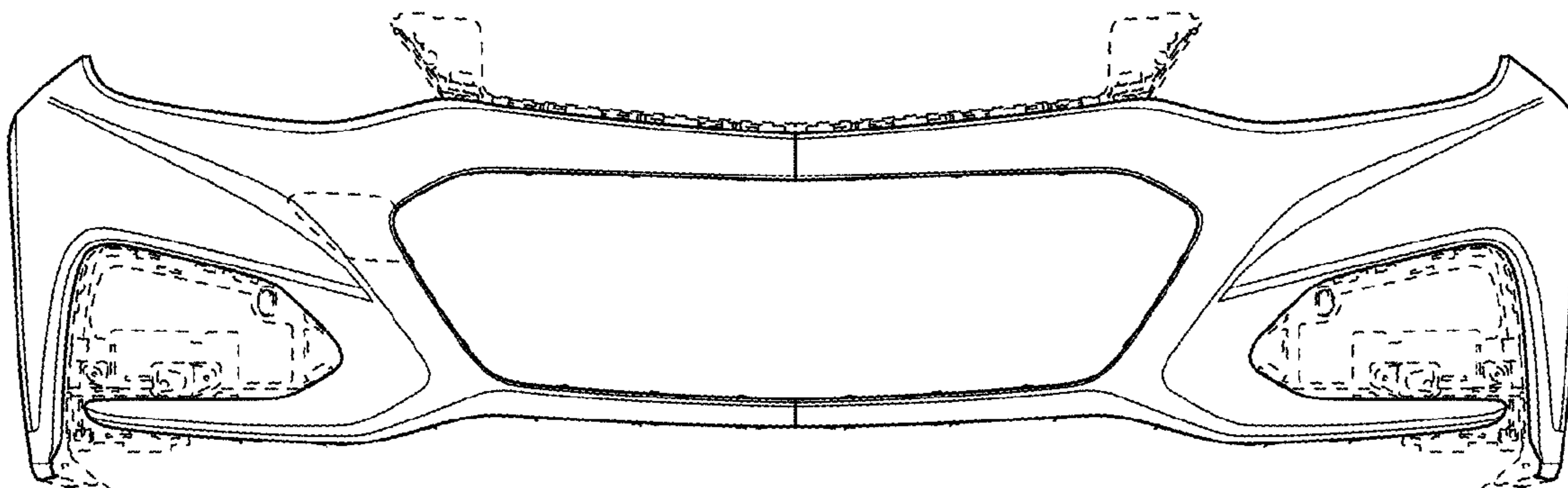

(56)

References Cited

U.S. PATENT DOCUMENTS

D623,090 S 9/2010 Cox et al.
 D627,262 S 11/2010 Ikeda et al.
 D635,488 S 4/2011 Phipps
 D643,350 S * 8/2011 Furst D12/169
 D644,147 S 8/2011 Suh et al.
 D644,567 S 9/2011 Kozub
 D647,440 S * 10/2011 Murakawa D12/169
 D657,718 S 4/2012 Zipfel et al.
 D659,052 S 5/2012 Ware et al.
 D659,053 S 5/2012 Ware et al.
 D664,901 S * 8/2012 Futschik D12/169
 D668,182 S 10/2012 Barba Franco
 D668,183 S 10/2012 Smart
 D668,189 S * 10/2012 Gifford D12/169
 D678,820 S 3/2013 Son et al.
 D678,821 S 3/2013 Ikeda et al.
 D680,909 S 4/2013 Munson et al.
 D680,910 S 4/2013 David
 D684,899 S 6/2013 Baker
 D686,119 S * 7/2013 Futschik D12/169
 D686,536 S 7/2013 McCabe et al.
 D691,526 S * 10/2013 Uchino D12/169
 D692,798 S 11/2013 Thurber
 D692,799 S 11/2013 Smith et al.
 D696,157 S 12/2013 Loeb
 D699,629 S 2/2014 Ikeda et al.
 D700,114 S * 2/2014 Wada D12/169
 D700,871 S 3/2014 O'Donnell et al.
 D703,103 S 4/2014 Lee
 D704,103 S 5/2014 Mack et al.
 D705,132 S 5/2014 Ware et al.
 D705,699 S 5/2014 Ware et al.
 D713,298 S 9/2014 Dyson
 D713,764 S 9/2014 Ferlazzo
 D716,200 S * 10/2014 Pevovar D12/169
 D716,696 S 11/2014 Thole et al.
 D716,706 S 11/2014 Thole et al.
 D716,709 S 11/2014 Thole et al.
 D717,696 S 11/2014 Thole et al.
 D718,189 S 11/2014 Krieg et al.

D718,683 S 12/2014 Thole et al.
 D722,282 S 2/2015 Loeb
 D722,533 S 2/2015 Thole et al.
 D722,534 S 2/2015 Munson et al.
 D724,503 S * 3/2015 Hall D12/169
 D724,510 S 3/2015 McMahan et al.
 D725,001 S 3/2015 McMahan et al.
 D726,591 S 4/2015 Jacob
 D730,776 S 6/2015 Smart
 D730,783 S 6/2015 Henriques et al.
 D732,427 S 6/2015 Loeb
 D732,429 S 6/2015 Loeb
 D732,430 S 6/2015 Loeb
 D732,431 S 6/2015 Loeb
 D732,432 S 6/2015 Aengenheyster
 D732,433 S 6/2015 Aengenheyster
 D732,435 S 6/2015 Mackay
 D733,002 S 6/2015 Loeb
 D735,611 S 8/2015 Aengenheyster
 D735,627 S 8/2015 Smith
 D736,451 S 8/2015 Smith
 D739,306 S 9/2015 McMahan et al.
 D739,317 S 9/2015 McMahan et al.
 D741,223 S 10/2015 Kim et al.
 D745,837 S * 12/2015 Smith D12/169
 D749,985 S * 2/2016 Kozub D12/92
 D750,000 S * 2/2016 Han D12/169
 D751,954 S * 3/2016 Choey D12/169
 D756,276 S * 5/2016 Minamisawa D12/169
 D760,631 S * 7/2016 Choi D12/169

OTHER PUBLICATIONS

Stoklosa, Alexander. "2016 Chevrolet Malibu: No Yawning!" caranddriver.com. Apr. 2015. Accessed Aug. 1, 2016. Available online at URL: <<http://www.caranddriver.com/news/2016-chevrolet-malibu-photos-and-info-news>>.*
 "First live photos and impressions of Chevy's 2014 Malibu." autoblog.com. May 31, 2013. Accessed Aug. 1, 2016. Available online at URL: <<http://www.autoblog.com/2013/05/31/2014-chevy-malibu-photos-impressions-reveal/#slide-146106>>.*

* cited by examiner

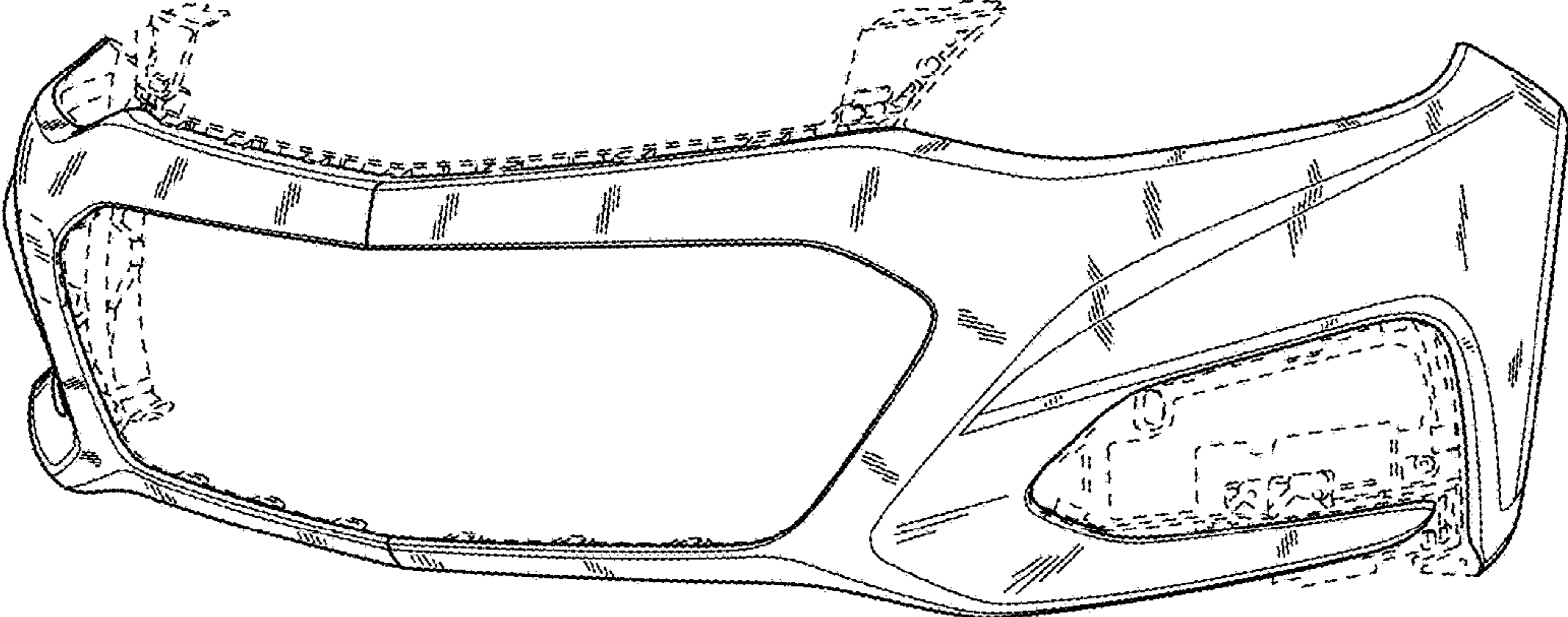

FIG. 1

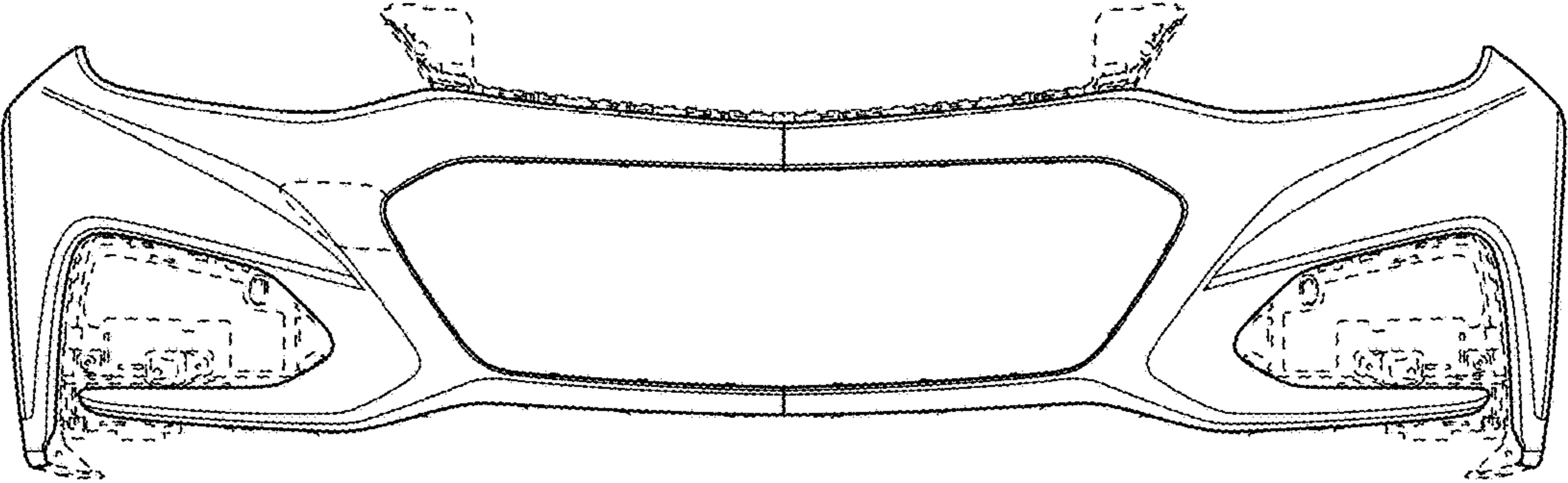

FIG. 2

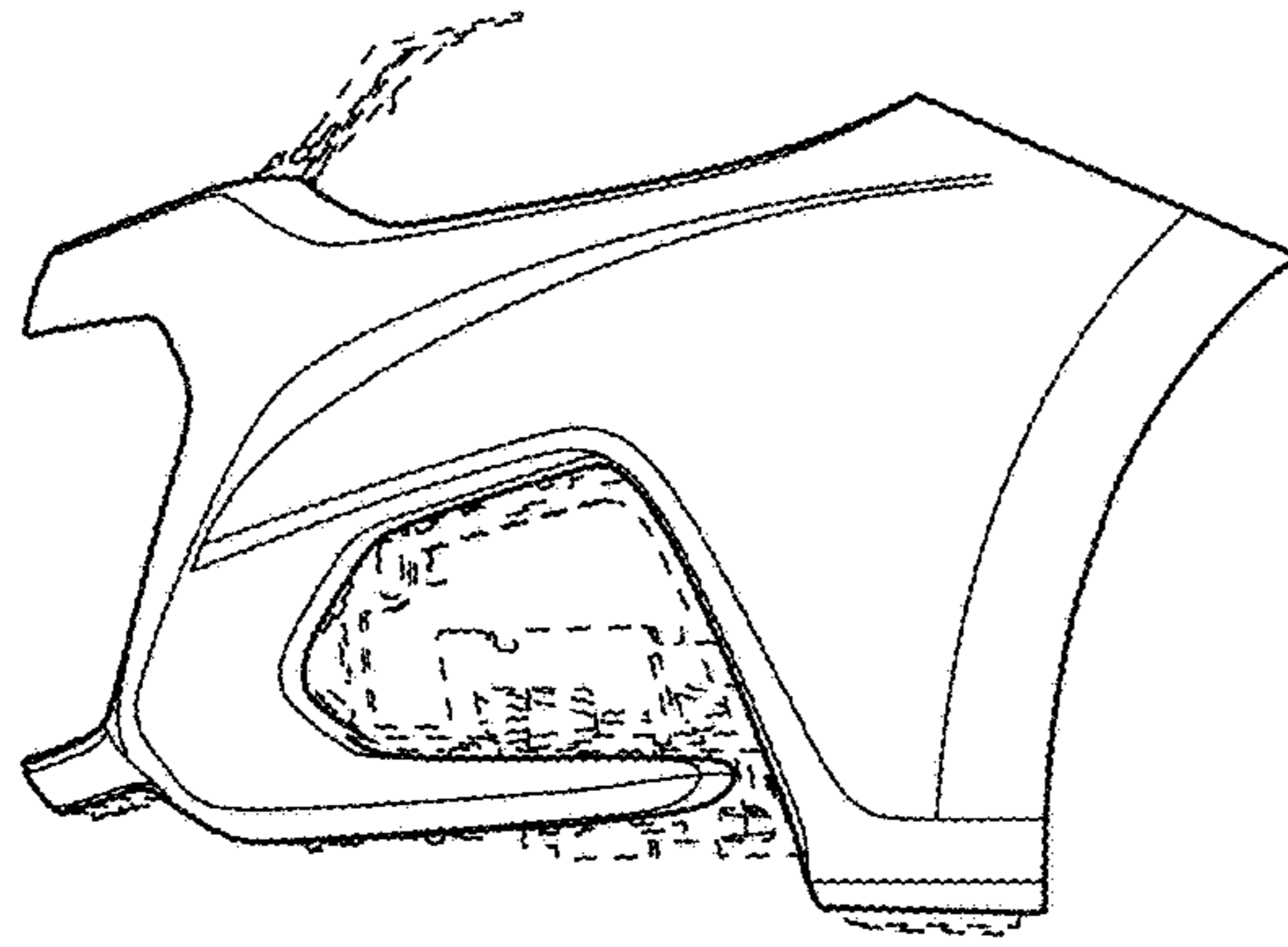

FIG. 3

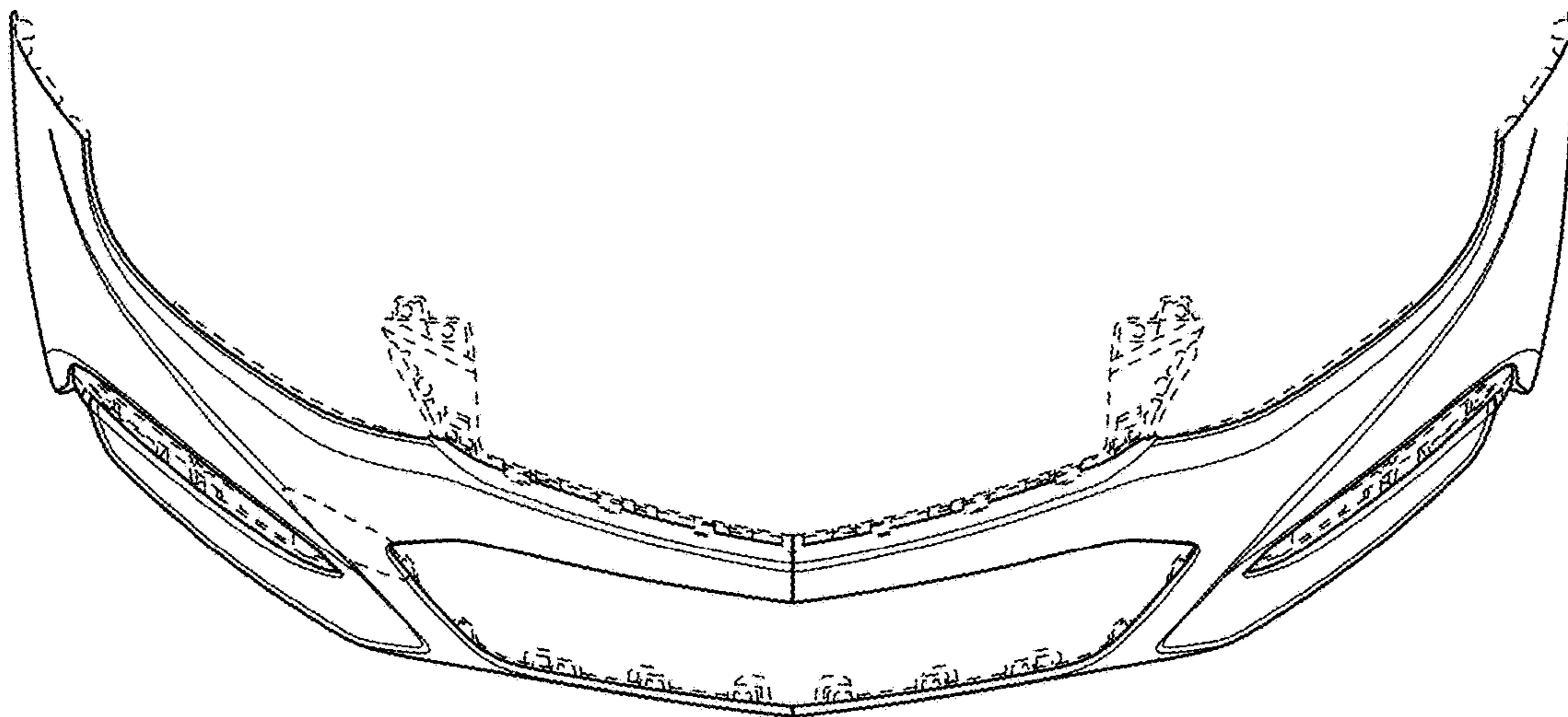

FIG. 4