



US00D787962S

(12) **United States Design Patent**
Scott et al.

(10) **Patent No.:** **US D787,962 S**
(45) **Date of Patent:** **** May 30, 2017**

(54) **SENSOR FOR A MULTI-PARAMETER SONDE**

Primary Examiner — Antoine D Davis
(74) *Attorney, Agent, or Firm* — Lathrop & Gage LLP

(71) Applicant: **In-Situ, Inc.**, Fort Collins, CO (US)

(72) Inventors: **Elijah Lyle Scott**, Loveland, CO (US);
Steven Collin Sewell, Fort Collins, CO (US)

(57) **CLAIM**

The ornamental design for a sensor for a multi-parameter sonde, as shown and described.

(73) Assignee: **In-Situ, Inc.**, Fort Collins, CO (US)

(**) Term: **15 Years**

DESCRIPTION

(21) Appl. No.: **29/558,413**

(22) Filed: **Mar. 17, 2016**

Related U.S. Application Data

(63) Continuation of application No. 29/513,888, filed on Jan. 6, 2015, now Pat. No. Des. 755,655.

(51) **LOC (10) Cl.** **10-04**

(52) **U.S. Cl.**
USPC **D10/81; D10/94**

(58) **Field of Classification Search**
USPC D10/78, 80, 81, 94, 103
(Continued)

FIG. 1 is a top and outer surface perspective view of sensor of a multi-parameter sonde;
FIG. 2 is a first inner-side view thereof;
FIG. 3 is a top, second inner-side, central surface perspective view thereof;
FIG. 4 is a second inner-side view thereof;
FIG. 5 is a bottom, first inner-side and central surface perspective view thereof;
FIG. 6 is a bottom, second inner-side, and central surface perspective view thereof;
FIG. 7 is a bottom and outer surface perspective view thereof;
FIG. 8 is a central surface view thereof;
FIG. 9 is an outer surface view thereof;
FIG. 10 is a top surface view thereof;
FIG. 11 is a bottom surface view thereof;
FIG. 12 is a top, first inner-surface, outer perspective view thereof; and
FIG. 13 is a bottom, central surface view thereof; and,
FIG. 14 is a top perspective view showing sensors of FIGS. 1-13 connected to a base and central support portion of a multi-parameter sonde, with one of the sensors removed, to illustrate the sensor in its intended environment; it being understood that the base and central support portion of the multi-parameter sonde forms no part of the claimed design. Only the distal end of the multi-parameter sonde is shown. The broken line showing of structural features is included for the purpose of illustrating non-claimed subject matter and forms no part of the claimed design.

(56) **References Cited**

U.S. PATENT DOCUMENTS

5,099,920 A 3/1992 Warburton et al.
5,259,452 A 11/1993 Wittrisch
(Continued)

FOREIGN PATENT DOCUMENTS

EP 1851537 9/2013
WO WO2006/088829 8/2006

OTHER PUBLICATIONS

U.S. Appl. No. 29/558,419, filed Mar. 17, 2016, Scott et al.
(Continued)

1 Claim, 13 Drawing Sheets

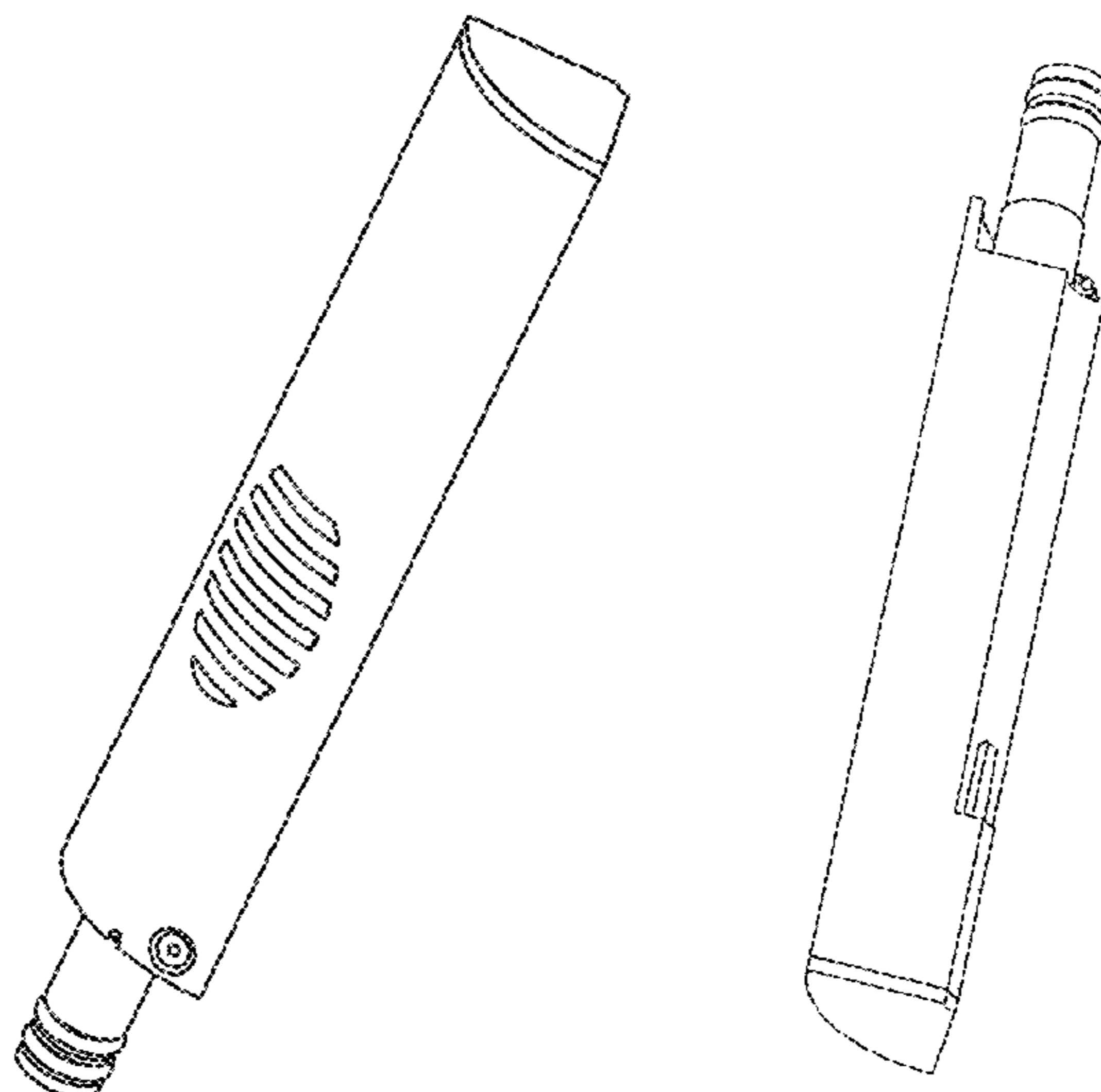

(58) **Field of Classification Search**

CPC G01N 33/22; G01N 33/221; G01N 33/18;
G01N 33/1806; G01N 33/1813; G01N
33/1893; G01N 33/182; G01N 33/1826;
G01N 33/1833; G01N 2033/184; G01N
33/1846; G01N 33/1853; G01N 33/186;
G01N 33/1866; G01N 2033/1873; G01N
33/01

See application file for complete search history.

(56) **References Cited**

U.S. PATENT DOCUMENTS

D371,517	S	7/1996	Narayanan	
5,596,193	A	1/1997	Chutjian et al.	
5,820,416	A	10/1998	Carmichael	
D418,073	S	12/1999	Kreutzer et al.	
6,157,029	A	12/2000	Chutjian et al.	
6,305,944	B1	10/2001	Henry et al.	
6,677,861	B1	1/2004	Henry et al.	
6,779,383	B2	8/2004	Lizotte et al.	
6,798,347	B2	9/2004	Henry et al.	
6,928,864	B1	8/2005	Henry et al.	
6,938,506	B2	9/2005	Henry et al.	
6,943,686	B2	9/2005	Allen	
7,007,541	B2	3/2006	Henry et al.	
7,138,926	B2	11/2006	Henry et al.	
7,142,299	B2	11/2006	Tokhtuev et al.	
7,470,917	B1	12/2008	Hoang et al.	
D616,314	S	5/2010	Akomolede	
7,832,295	B2	11/2010	Rodriguez et al.	
7,900,528	B2	3/2011	Vincent	
8,429,952	B1	4/2013	Bringhurst et al.	
8,488,122	B2	7/2013	Dong et al.	
8,514,066	B2	8/2013	Harmon	
8,542,189	B2	9/2013	Milne et al.	
8,555,482	B2	10/2013	Metzger	
8,797,523	B2	8/2014	Clark	
8,877,027	B2 *	11/2014	Ishii	G01N 27/30 204/416
9,194,854	B2 *	11/2015	Andersen	G01N 33/186
9,267,881	B2 *	2/2016	Furtaw	G01N 21/3504
D755,655	S *	5/2016	Scott	D10/81
2003/0117623	A1	6/2003	Tokhtuev et al.	
2003/0148637	A1	8/2003	Henry et al.	
2007/0140921	A1	6/2007	Mitchell	
2009/0158819	A1	6/2009	Vincent	
2010/0321046	A1	12/2010	Randall et al.	
2011/0023586	A1	2/2011	Leyer et al.	
2011/0273710	A1	11/2011	Dong et al.	
2012/0242993	A1	9/2012	Schick et al.	
2012/0262618	A1	10/2012	Weakly	
2013/0090789	A1	4/2013	DeDonato	
2014/0017143	A1	1/2014	Clark	
2016/0139046	A1	5/2016	Baltz et al.	
2016/0139070	A1	5/2016	Scott et al.	
2016/0139101	A1	5/2016	Scott et al.	
2016/0146777	A1	5/2016	McKee	

OTHER PUBLICATIONS

U.S. Appl. No. 29/558,414, filed Mar. 17, 2016, Scott et al.
U.S. Appl. No. 29/558,417, filed Mar. 17, 2016, Scott et al.
U.S. Appl. No. 15/148,832, filed May 6, 2016, Steinbach et al.
Sonde Wikipedia, accessed Nov. 4, 2015.
Teledyne Isco AQ700 Water Quality Multi-Parameter Sonde, 2 pages, Sep. 2013.
YSI EXO1 Multiparameter Sonde, <http://www.ysi.com/productsdetail.php?EXO1-Water-Quality-Sonde-89>, webpage publicly available at least as early as Oct. 2014.
YSI EXO2 Multiparameter Sonde, <https://www.ysi.com/EXO2>, webpage publicly available at least as early as Oct. 2014.
Hydrolab HL4 <http://hydrolab.com/hydrolab-hl4-multiparameter-sonde/>, webpage publicly available at least as early as May 6, 2014.
Ott Hydrolab DS5 <http://www.ott.com/products/water-quality/hydrolab-ds5-multiparameter-data-sonde/>, webpage publicly available at least as early as Oct. 2014.
In Situ Troll 9500 Multiparameter Sonde, <https://in-situ.com/products/water-quality-testing-equipment/troll-9500-multiparameter-sonde/>, webpage publicly available at least as early as Apr. 1, 2015.
In Situ Aqua Troll 600 Multiparameter Sonde, <https://in-situ.com/products/water-quality-testing-equipment/aqua-troll-600-multiparameter-sonde/>, webpage publicly available at least as early as Sep. 14, 2015.
In Situ AquaTROLL 600 Product Information, <https://in-situ.com/blog/introducing-the-aqua-troll-600-water-quality-platform-2/>, webpage publicly available at least as early as Sep. 21, 2015.
In Situ AquaTROLL 600 Specification Sheet, https://in-situ.com/wp-content/uploads/2015/09/Aqua_TROLL_600_Spec.pdf, webpage publicly available at least as early as Apr. 30, 2016.
In Situ Water Quality Testing Equipment Products, <https://in-situ.com/product-category/water-quality-testing-equipment/>, webpage publicly available at least as early as Apr. 1, 2015.
Examiner's Report for corresponding CA Application No. 163113, dated Nov. 16, 2015, 3 pages.
6-Series Multiparameter Water Quality Sondes, YSI Environmental, dated Aug. 24, 2006, 14 pages.
International Search Report with Written Opinion corresponding to International Patent Application No. PCT/US2015/059925, mailed Jan. 20, 2016, 8 pages.
International Search Report with Written Opinion corresponding to International Patent Application No. PCT/US2015/059920, mailed Jan. 29, 2016, 7 pages.
International Search Report and Written Opinion corresponding to International Patent Application No. PCT/US2015/059918, mailed Feb. 1, 2016, 8 pages.
International Search Report with Written Opinion corresponding to International Patent Application No. PCT/US2015/059939, mailed Jan. 13, 2016, 9 pages.
U.S. Appl. No. 29/558,419, filed Mar. 17, 2016.
U.S. Appl. No. 29/558,414, filed Mar. 17, 2016.
U.S. Appl. No. 29/558,417, filed Mar. 17, 2016.
U.S. Appl. No. 15/148,832, filed May 6, 2016.

* cited by examiner

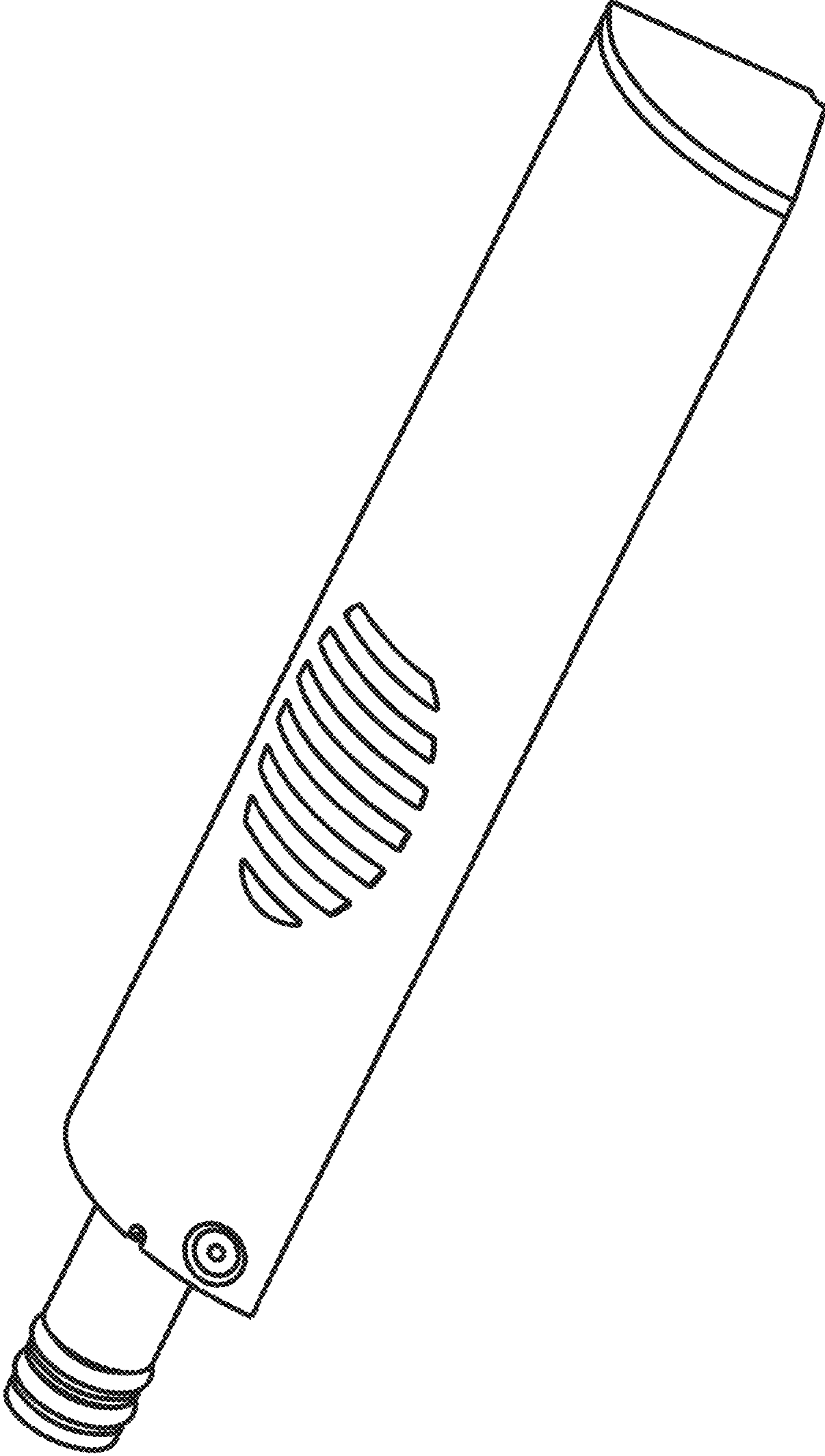

FIG. 1

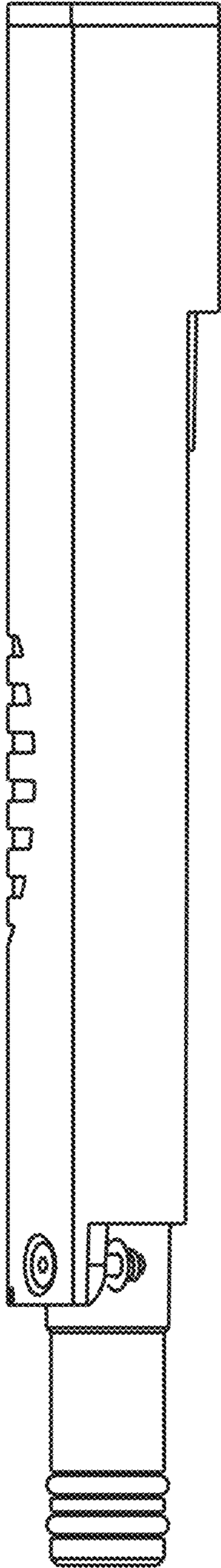

FIG. 2

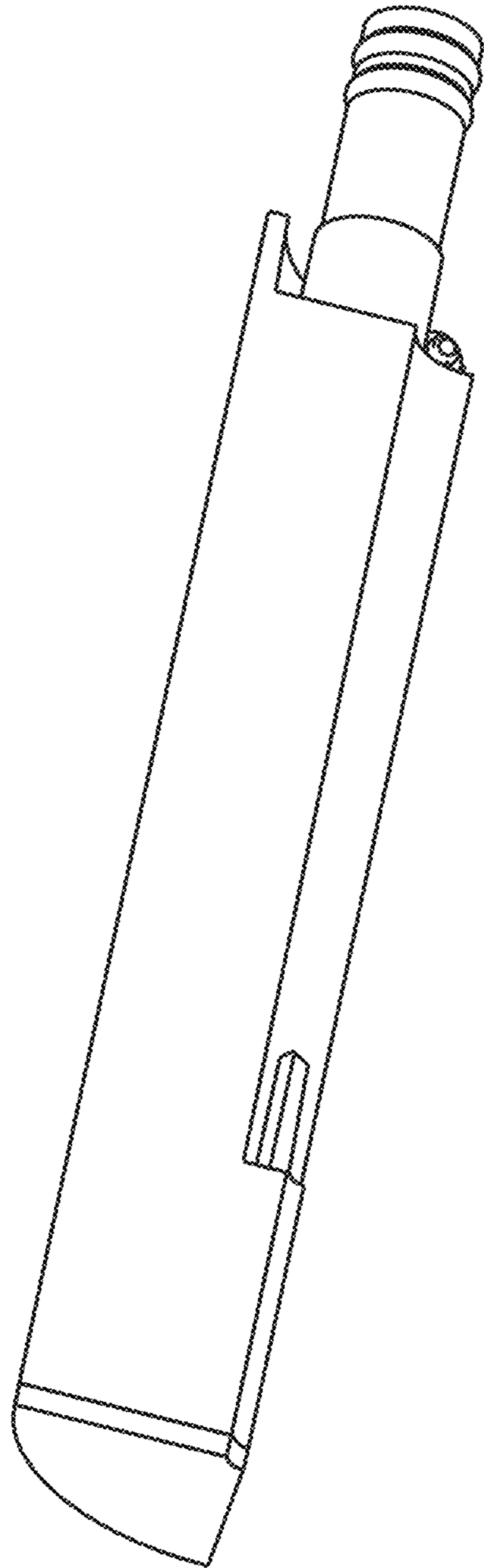

FIG. 3

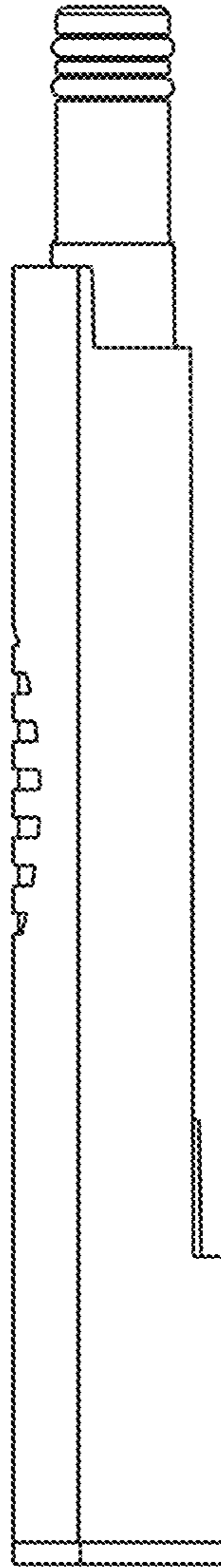

FIG. 4

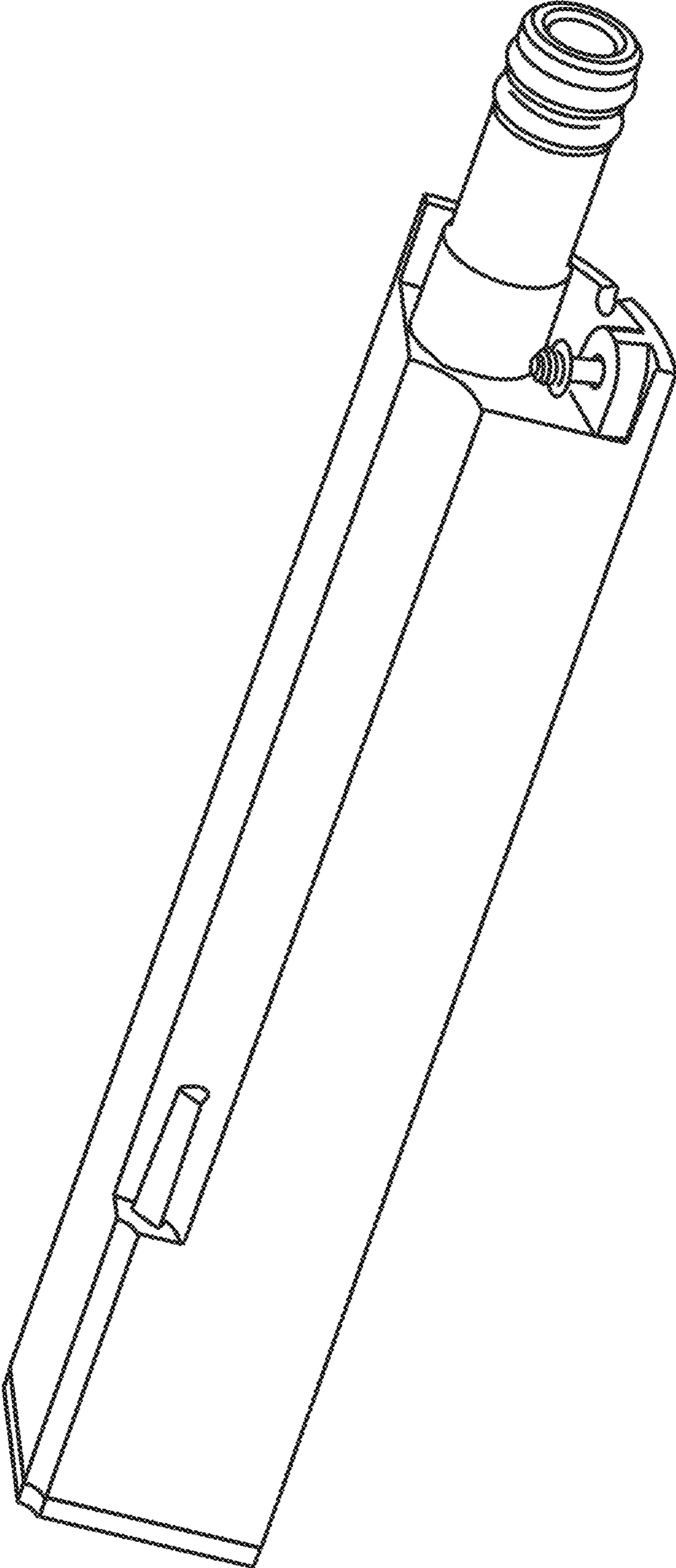

FIG. 5

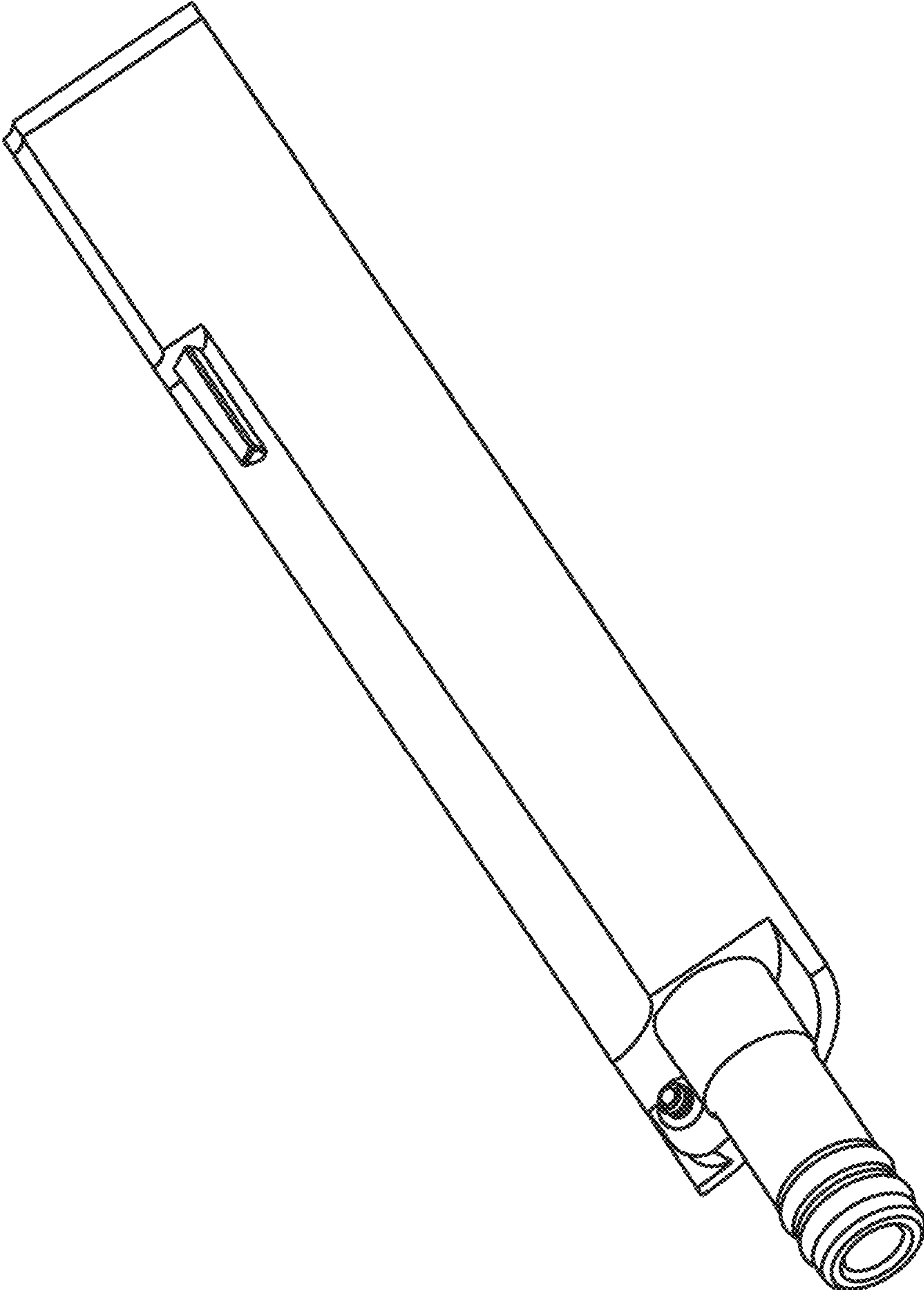

FIG. 6

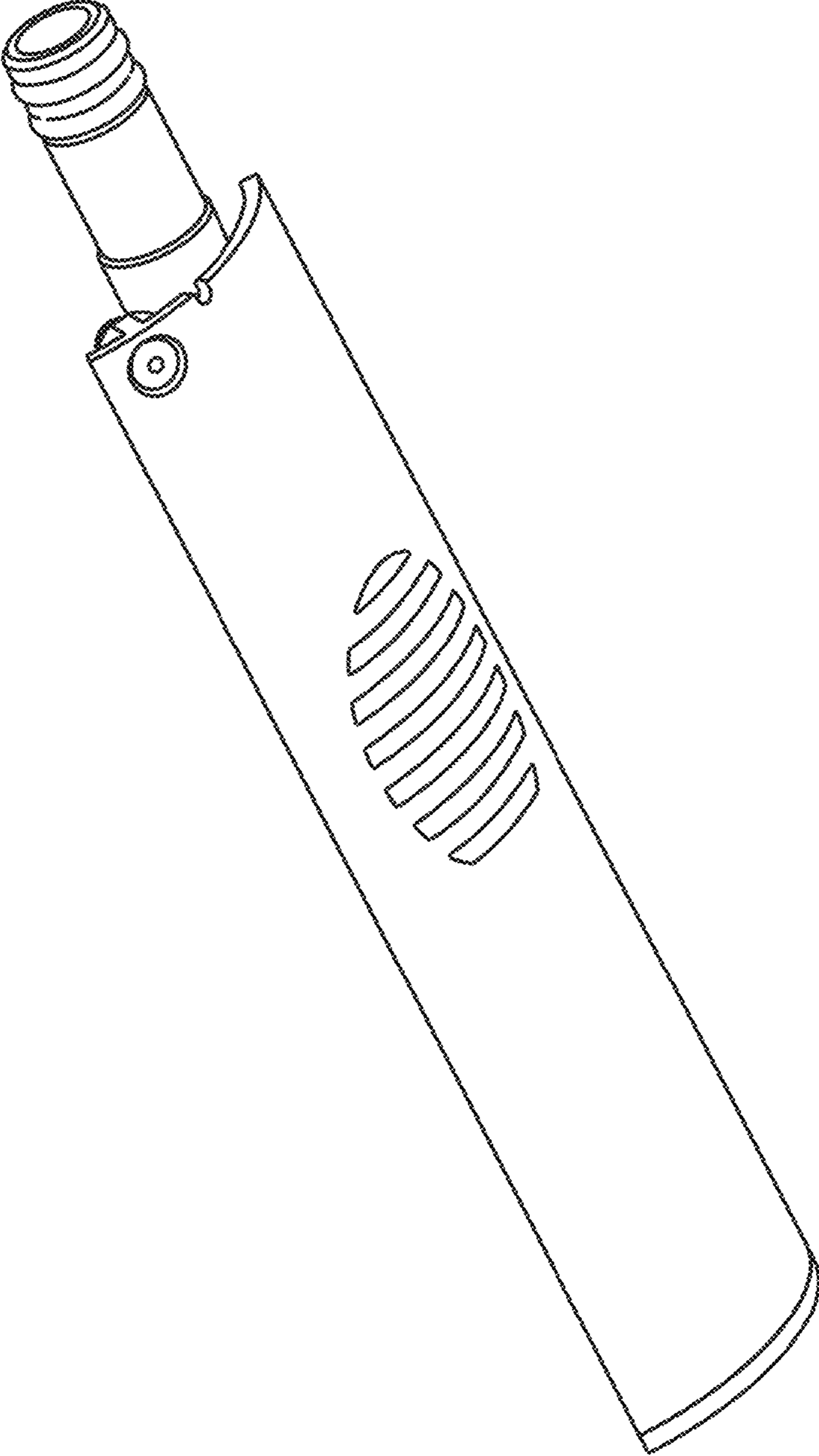

FIG. 7

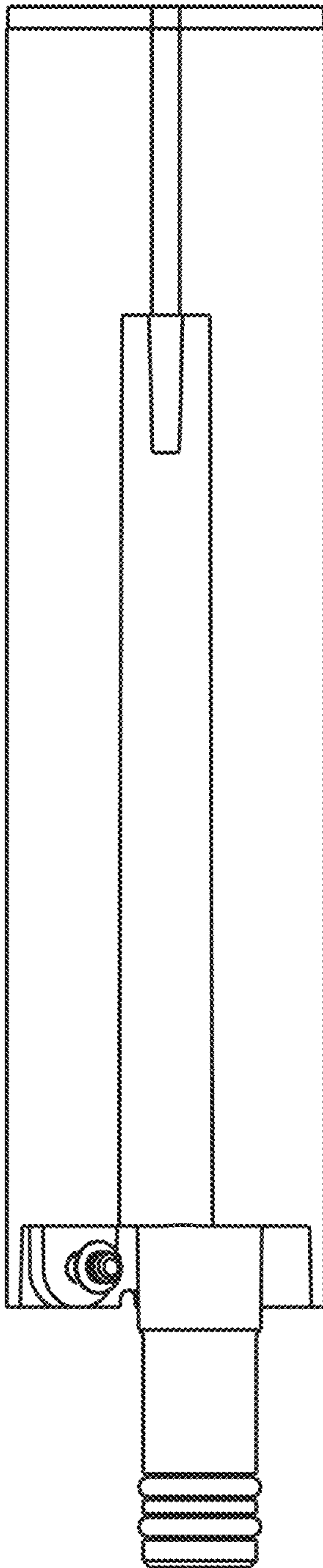

FIG. 8

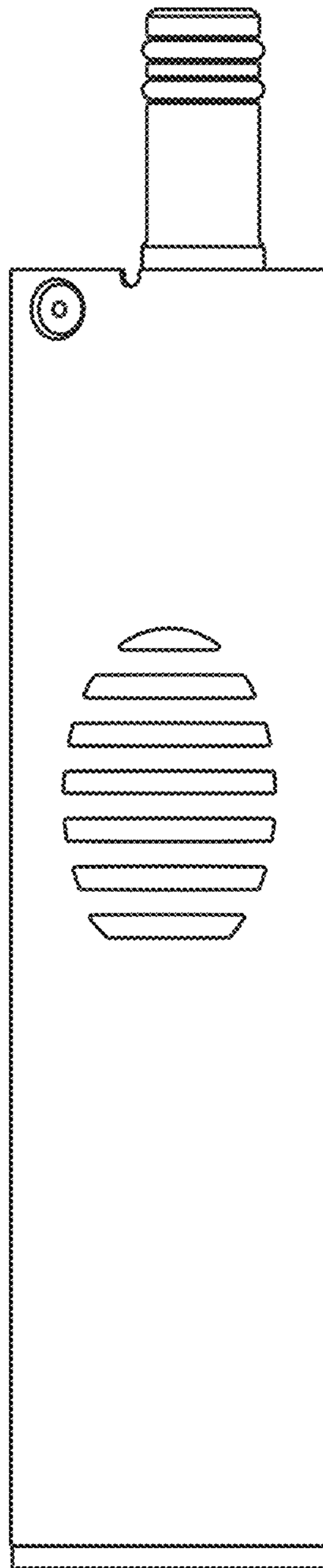

FIG. 9

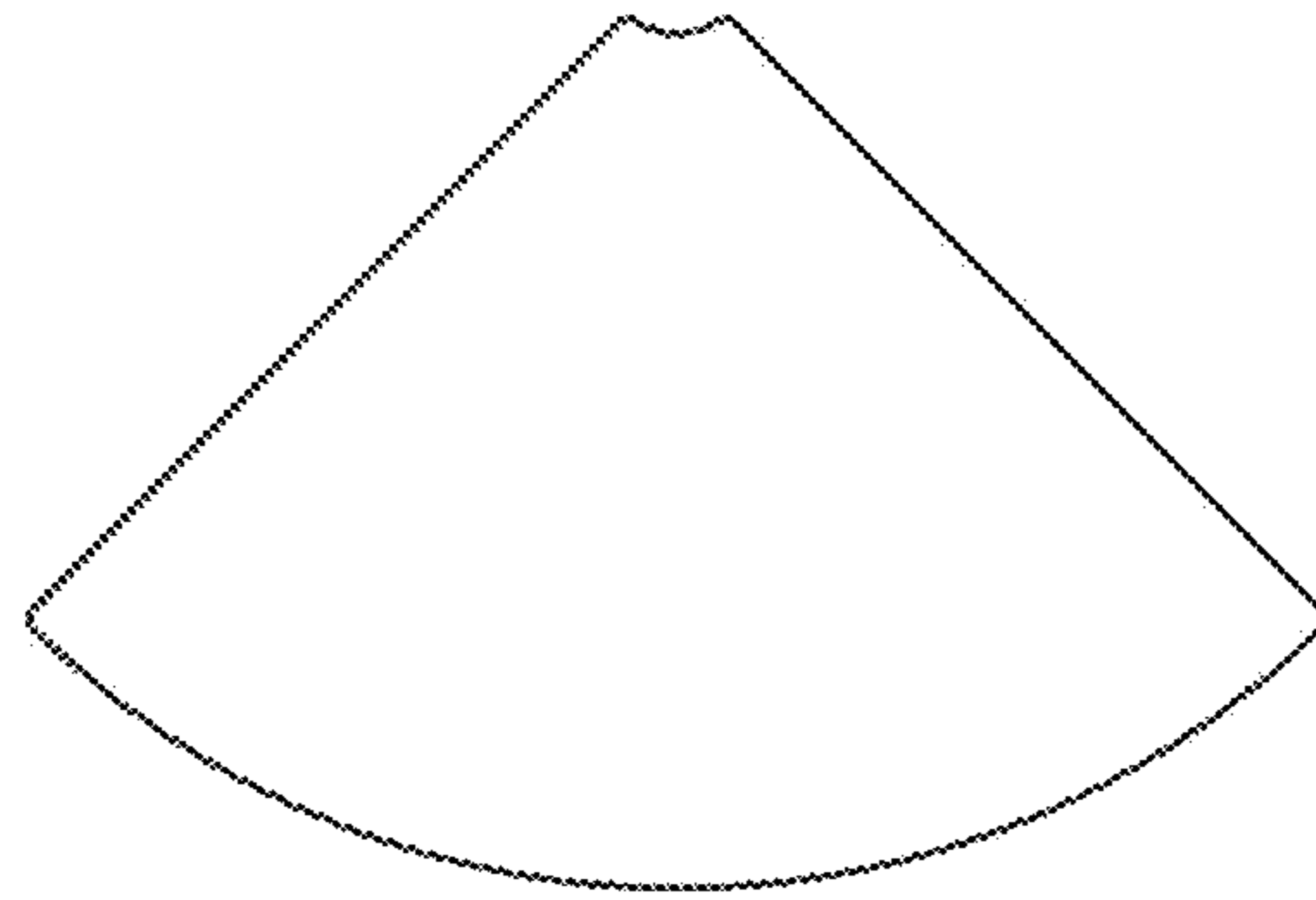

FIG. 10

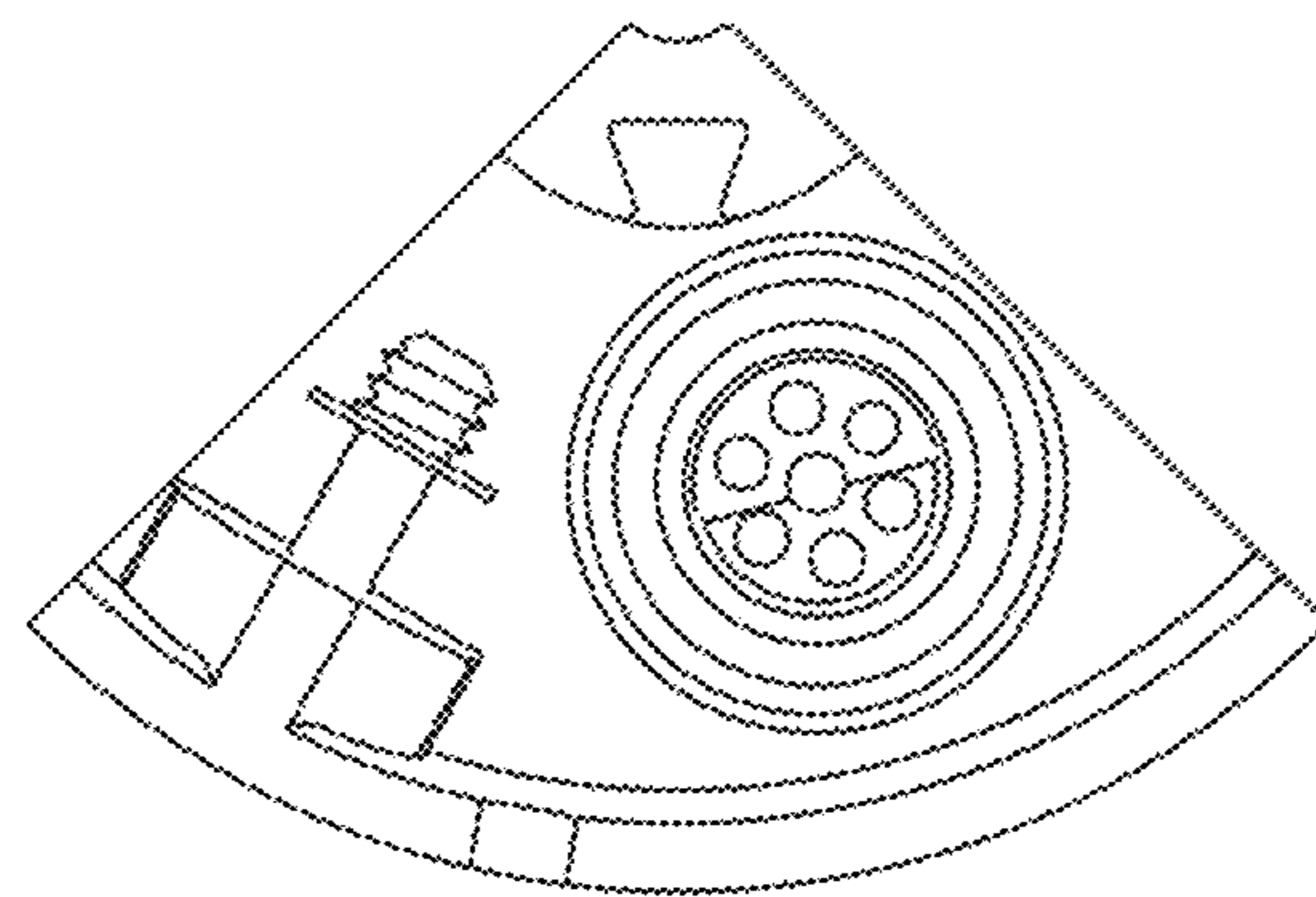

FIG. 11

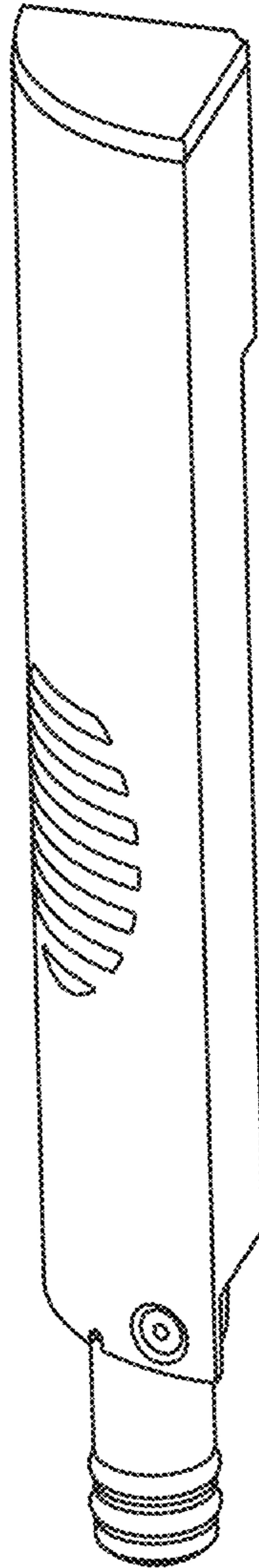

FIG. 12

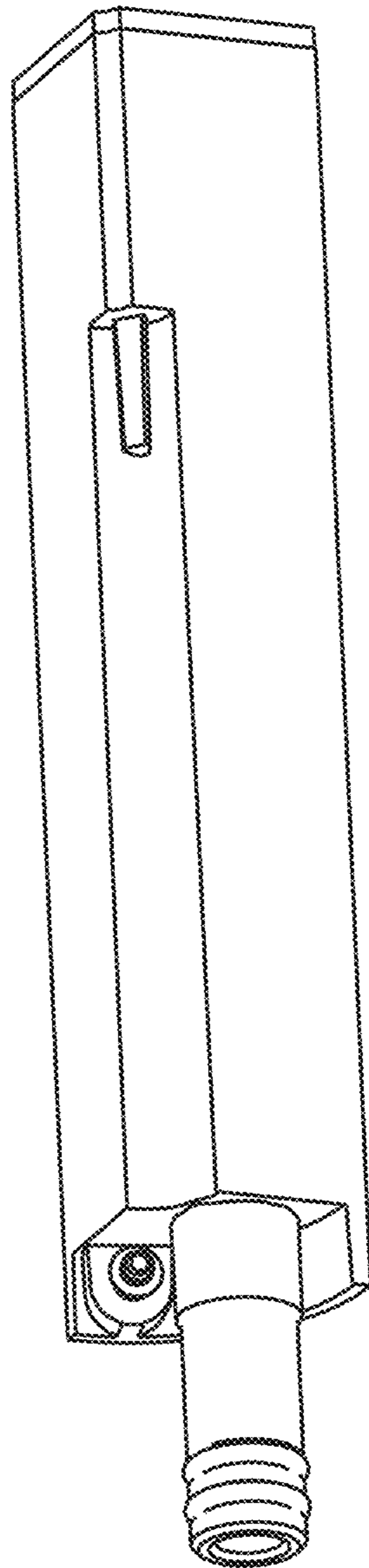

FIG. 13

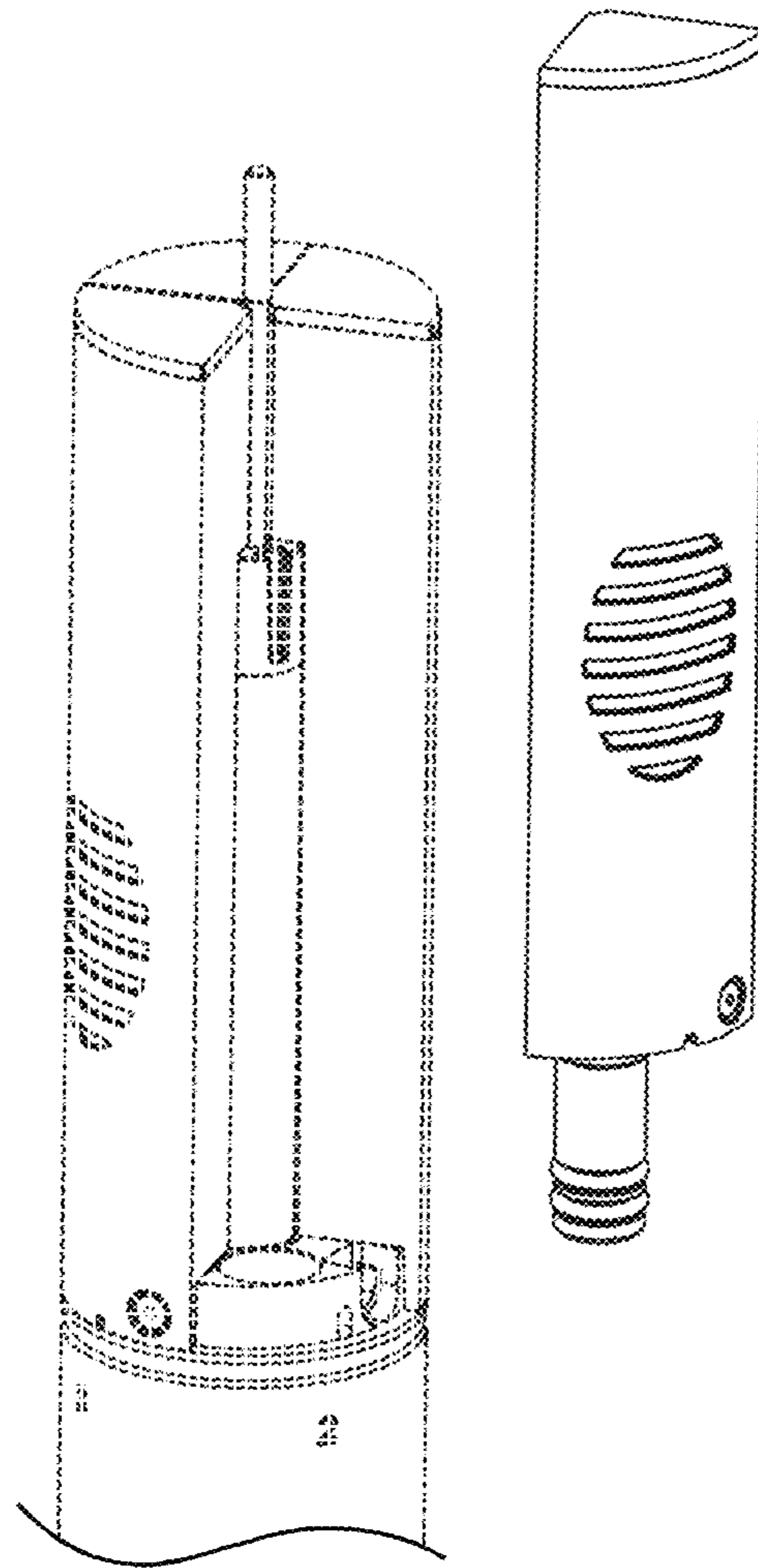

FIG. 14