



US00D787931S

(12) **United States Design Patent**  
**Beck et al.**

(10) **Patent No.:** **US D787,931 S**  
(45) **Date of Patent:** **\*\* May 30, 2017**

(54) **MACHINE PARTS PACKAGING**

(71) Applicant: **Groz-Beckert KG**, Albstadt (DE)

(72) Inventors: **Thomas Beck**, Albstadt (DE); **Jörg Bredemeyer**, Balingen (DE); **Thomas Zindritsch**, Bisingen (DE); **Torsten Butz**, Meßstetten (DE)

(73) Assignee: **GROZ-BECKERT KG**, Albstadt (DE)

(\*\*) Term: **14 Years**

(21) Appl. No.: **29/512,065**

(22) Filed: **Dec. 16, 2014**

(30) **Foreign Application Priority Data**

Jun. 16, 2014 (EM) ..... 002483172-0004

(51) **LOC (10) Cl.** ..... **09-03**

(52) **U.S. Cl.**  
USPC ..... **D9/432**

(58) **Field of Classification Search**  
USPC ..... D9/414–415, 417, 418, 420–427,  
D9/430–434, 634, 721, 783–744, 751,  
(Continued)

(56) **References Cited**

**U.S. PATENT DOCUMENTS**

2,846,806 A \* 8/1958 Gaines ..... A01K 97/06  
206/315.1  
3,033,355 A \* 5/1962 Van Sickle ..... B65D 43/12  
206/539

(Continued)

*Primary Examiner* — Vy Koenig

(74) *Attorney, Agent, or Firm* — Fitch, Even, Tabin & Flannery LLP

(57) **CLAIM**

We claim the ornamental design for machine parts packaging, as shown and described.

**DESCRIPTION**

FIG. 1 is a perspective view of the new design of machine parts packaging with the machine parts in place and a first insert removed and shown and a second insert within the machine parts packaging box;

FIG. 2 is the perspective view of FIG. 1 of the machine parts packaging with the lid removed, the first insert in place, and several of the machine parts placed in the machine parts packaging;

FIG. 3 is the perspective view of FIG. 2 with all the machine parts placed in the machine parts packaging;

FIG. 4 is a perspective view of the machine parts packaging of FIG. 1 with the lid in place;

FIG. 5 is a top view of the machine parts packaging of FIG. 1 with the lid removed, the first insert in place, and the machine parts removed;

FIG. 6 is the top view of FIG. 5 with the first insert removed and the machine parts placed in the machine parts packaging;

FIG. 7 is a front view of the machine parts packaging of FIG. 1 with the lid in place;

FIG. 8 is a back view of the machine parts packaging of FIG. 1 with the lid in place;

FIG. 9 is a perspective view of the machine parts packaging of FIG. 1 shown separately for clarity and ease of illustration with the lid and inserts removed;

FIG. 10 is a top view of the machine parts packaging of FIG. 1 shown separately for clarity and ease of illustration with the lid and inserts removed;

FIG. 11 is a bottom view of the machine parts packaging of FIG. 1 shown separately for clarity and ease of illustration with the lid and inserts removed;

FIG. 12 is a right side view of the machine parts packaging of FIG. 1 shown separately for clarity and ease of illustration with the lid and inserts removed;

FIG. 13 is a left side view of the machine parts packaging of FIG. 1 shown separately for clarity and ease of illustration with the lid and inserts removed;

FIG. 14 is a front view of the machine parts packaging of FIG. 1 shown separately for clarity and ease of illustration with the lid and inserts removed;

(Continued)

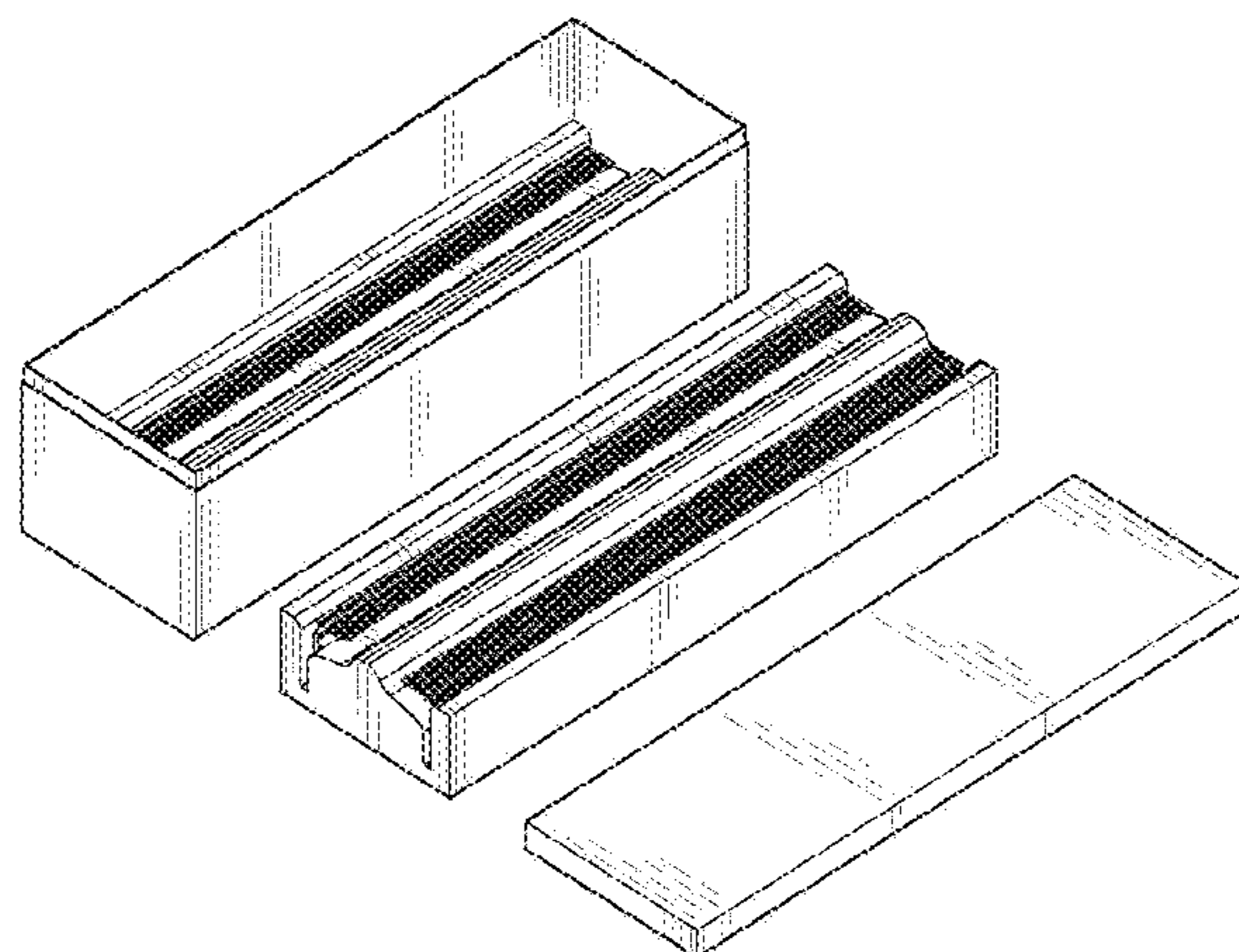

FIG. 15 is a back view of the machine parts packaging of FIG. 1 shown separately for clarity and ease of illustration with the lid and inserts removed;

FIG. 16 is a top perspective view of the lid for the machine parts packaging of FIG. 1 shown separately for clarity and ease of illustration;

FIG. 17 is a bottom perspective view of the lid of the machine parts packaging of FIG. 1 shown separately for clarity and ease of illustration;

FIG. 18 is a top view of the lid for the machine parts packaging of FIG. 1 shown separately for clarity and ease of illustration;

FIG. 19 is a bottom view of the lid of the machine parts packaging of FIG. 1 shown separately for clarity and ease of illustration;

FIG. 20 is a right side view of the lid of the machine parts packaging of FIG. 1 shown separately for clarity and ease of illustration;

FIG. 21 is a left side view of the lid of the machine parts packaging of FIG. 1 shown separately for clarity and ease of illustration;

FIG. 22 is a front view of the lid of the machine parts packaging of FIG. 1 shown separately for clarity and ease of illustration;

FIG. 23 is a back view of the lid of the machine parts packaging of FIG. 1 shown separately for clarity and ease of illustration;

FIG. 24 is a perspective view of one of the two inserts of the machine parts packaging shown separately for clarity and ease of illustration;

FIG. 25 is a top view of one of the two inserts of the machine parts packaging shown separately for clarity and ease of illustration;

FIG. 26 is a bottom view of one of the two inserts of the machine parts packaging shown separately for clarity and ease of illustration;

FIG. 27 is a right side view of one of the two inserts of the machine parts packaging shown separately for clarity and ease of illustration;

FIG. 28 is a left side view of one of the two inserts of the machine parts packaging shown separately for clarity and ease of illustration;

FIG. 29 is a front view of one of the two inserts of the machine parts packaging shown separately for clarity and ease of illustration; and,

FIG. 30 is a back view of one of the two inserts of the machine parts packaging shown separately for clarity and ease of illustration.

The broken lines shown in the drawings illustrate environmental subject matter, specifically machine parts, and form no part of the claimed design.

**1 Claim, 18 Drawing Sheets**

(58) **Field of Classification Search**

USPC ..... D9/756, 759, 760; D3/272, 273, 302,  
D3/304–309, 315; D7/601, 602, 609,  
D7/619.1, 630

CPC ..... B65D 5/00–5/02; B65D 5/0209–5/0272;  
B65D 5/029; B65D 5/40; B65D 5/72;  
B65D 5/727

See application file for complete search history.

(56) **References Cited**

U.S. PATENT DOCUMENTS

D197,988	S *	4/1964	Slaton	.....	D19/83
D229,673	S *	12/1973	Danjeczek	.....	D9/759
D267,700	S *	1/1983	Skarin	.....	206/443
D326,409	S *	5/1992	Krueger	.....	D9/424
6,915,899	B2 *	7/2005	Lin	.....	A01K 97/06 206/315.11
D591,593	S *	5/2009	Stannard	.....	D9/756
D664,043	S *	7/2012	Hofmann	.....	D9/751
8,333,281	B2 *	12/2012	Saltsov	.....	A61J 1/03 206/1.5
D691,465	S *	10/2013	O'Brien	.....	D9/418

\* cited by examiner



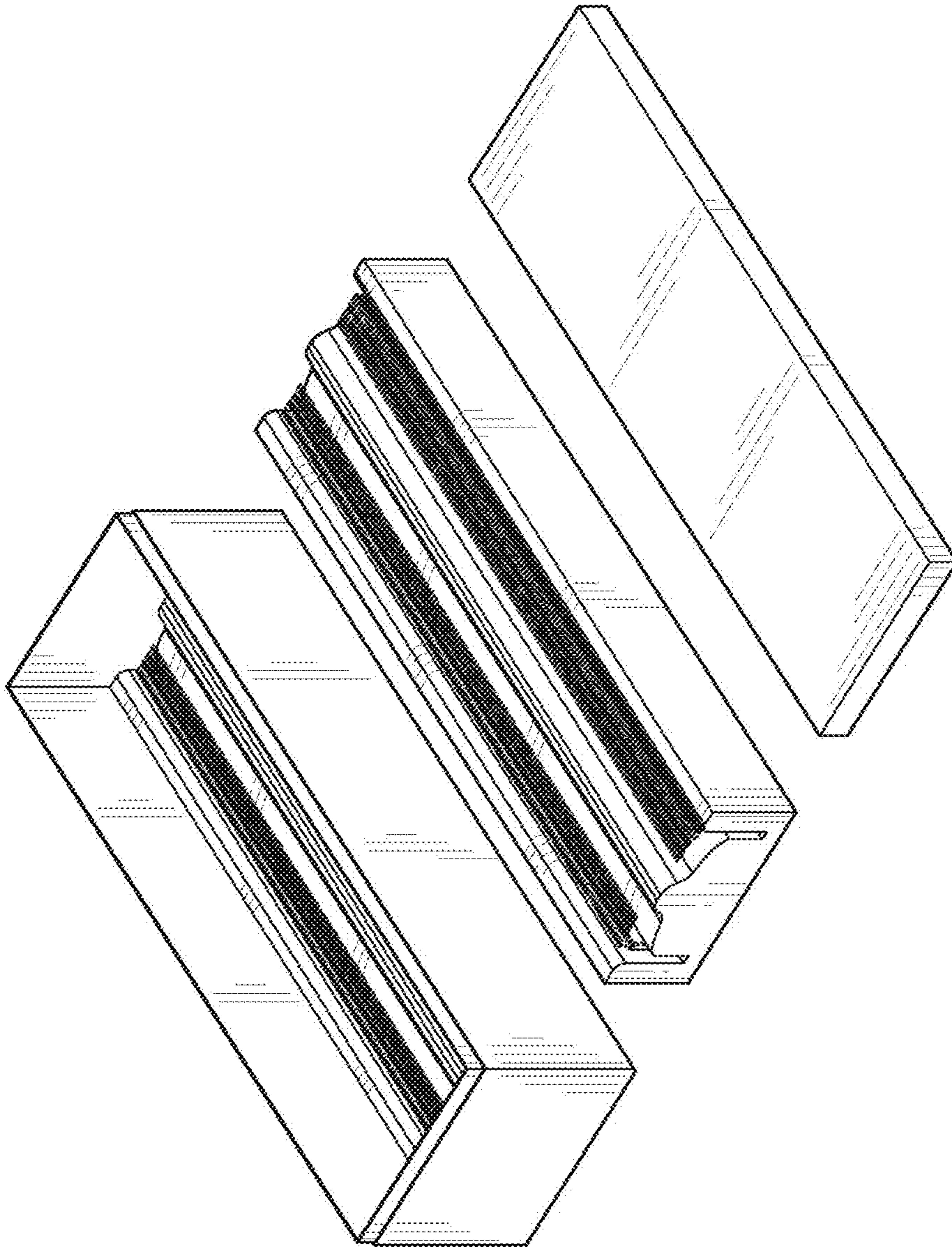

FIG. 1

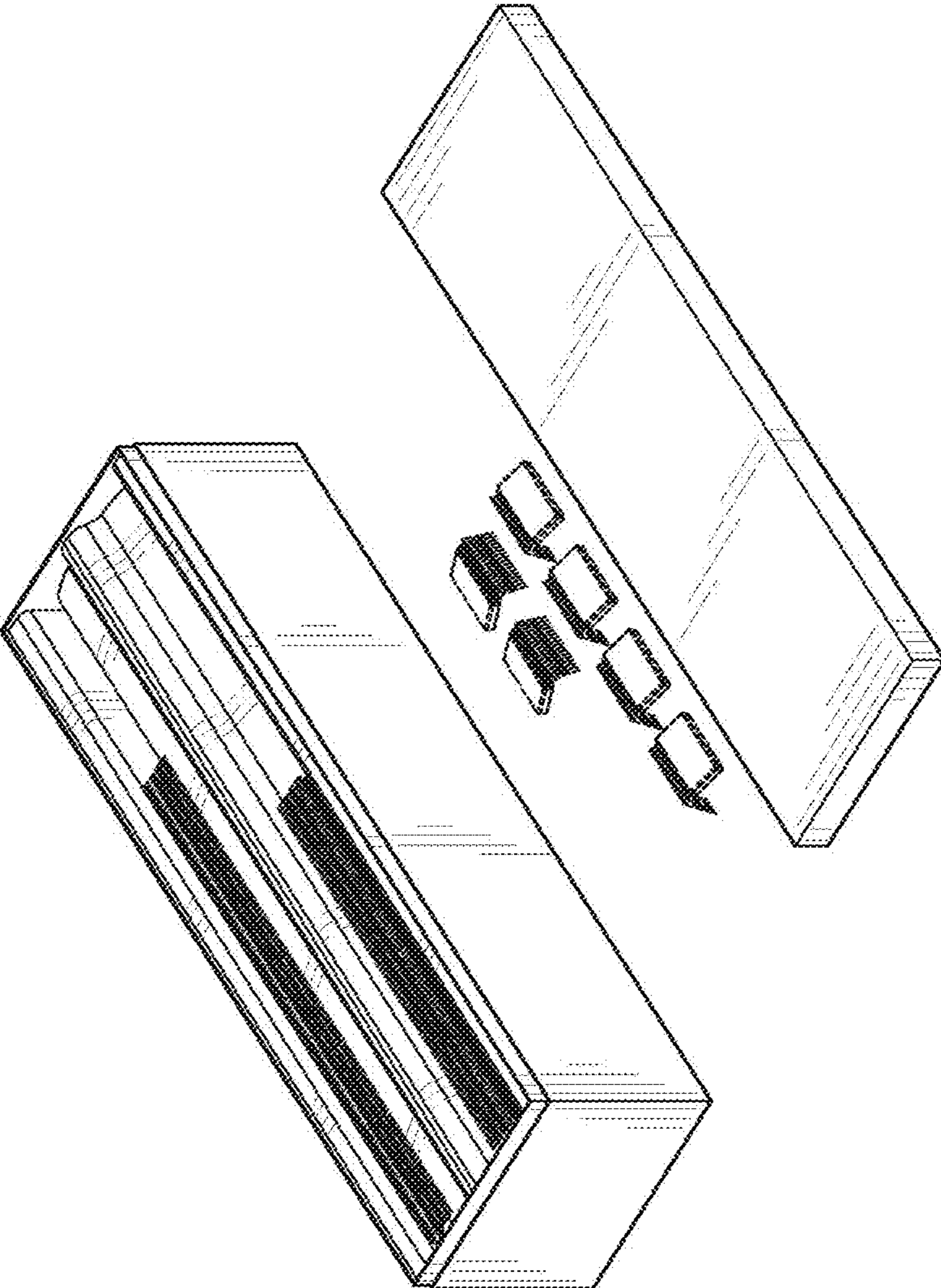

FIG. 2

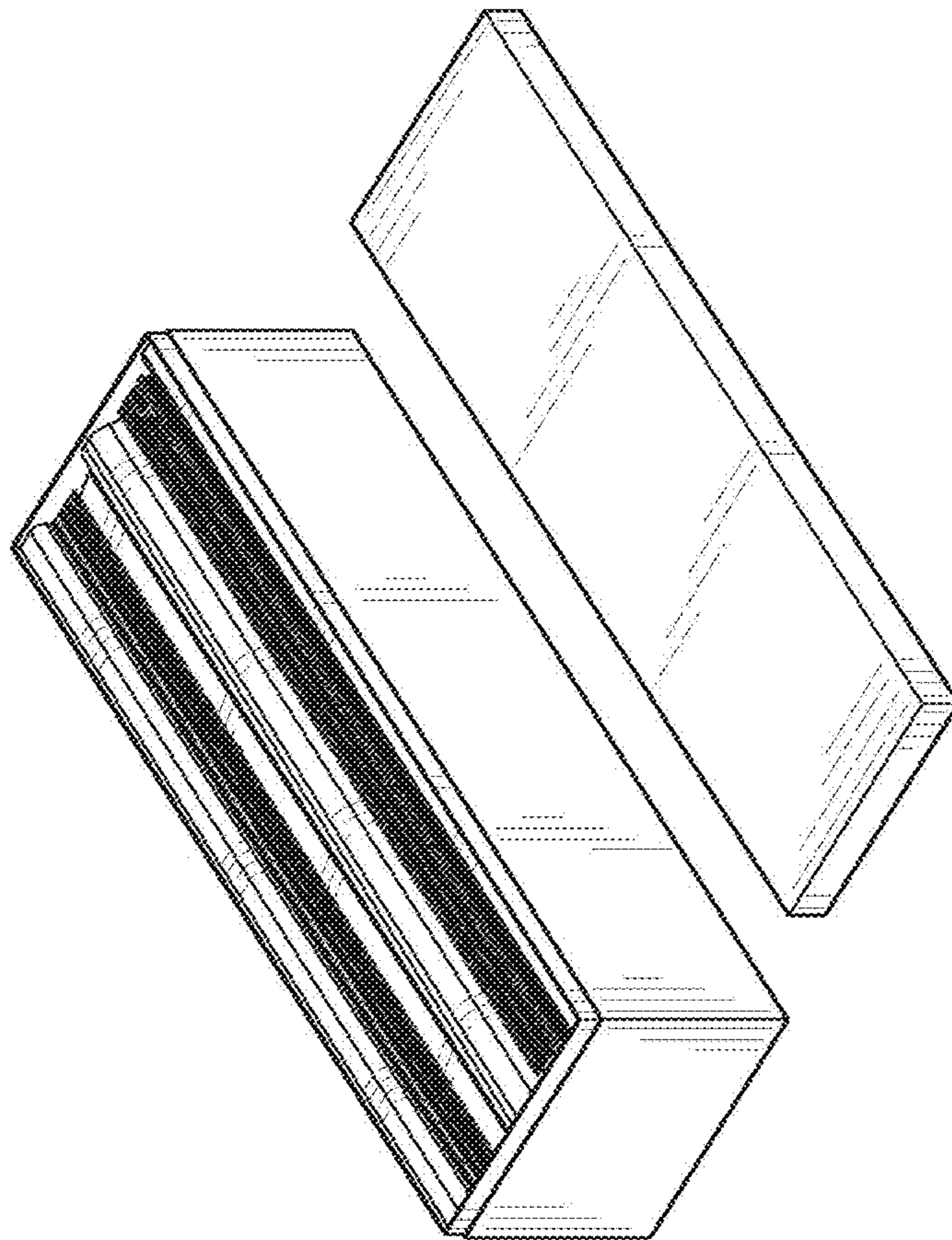

FIG. 3

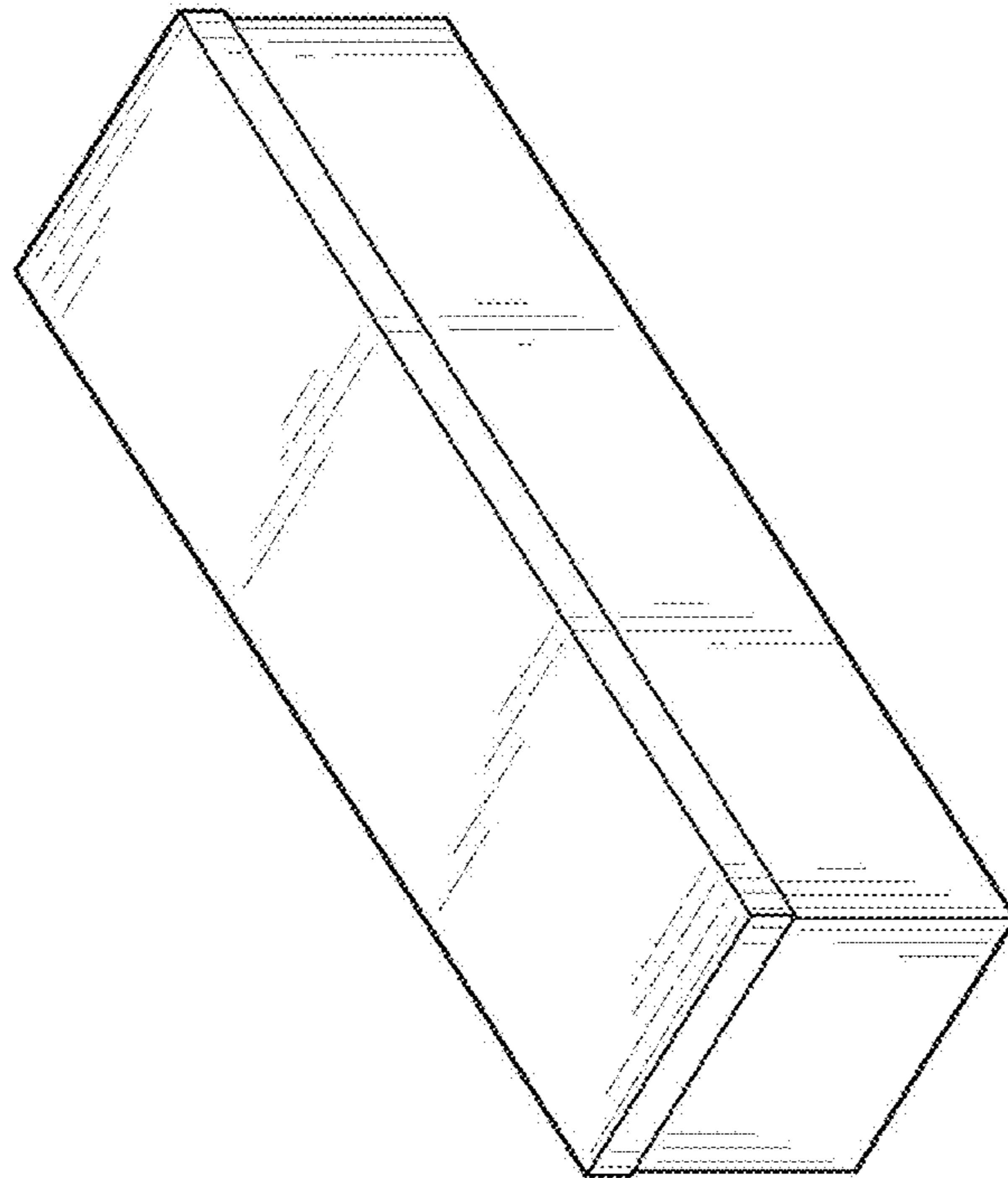

FIG. 4



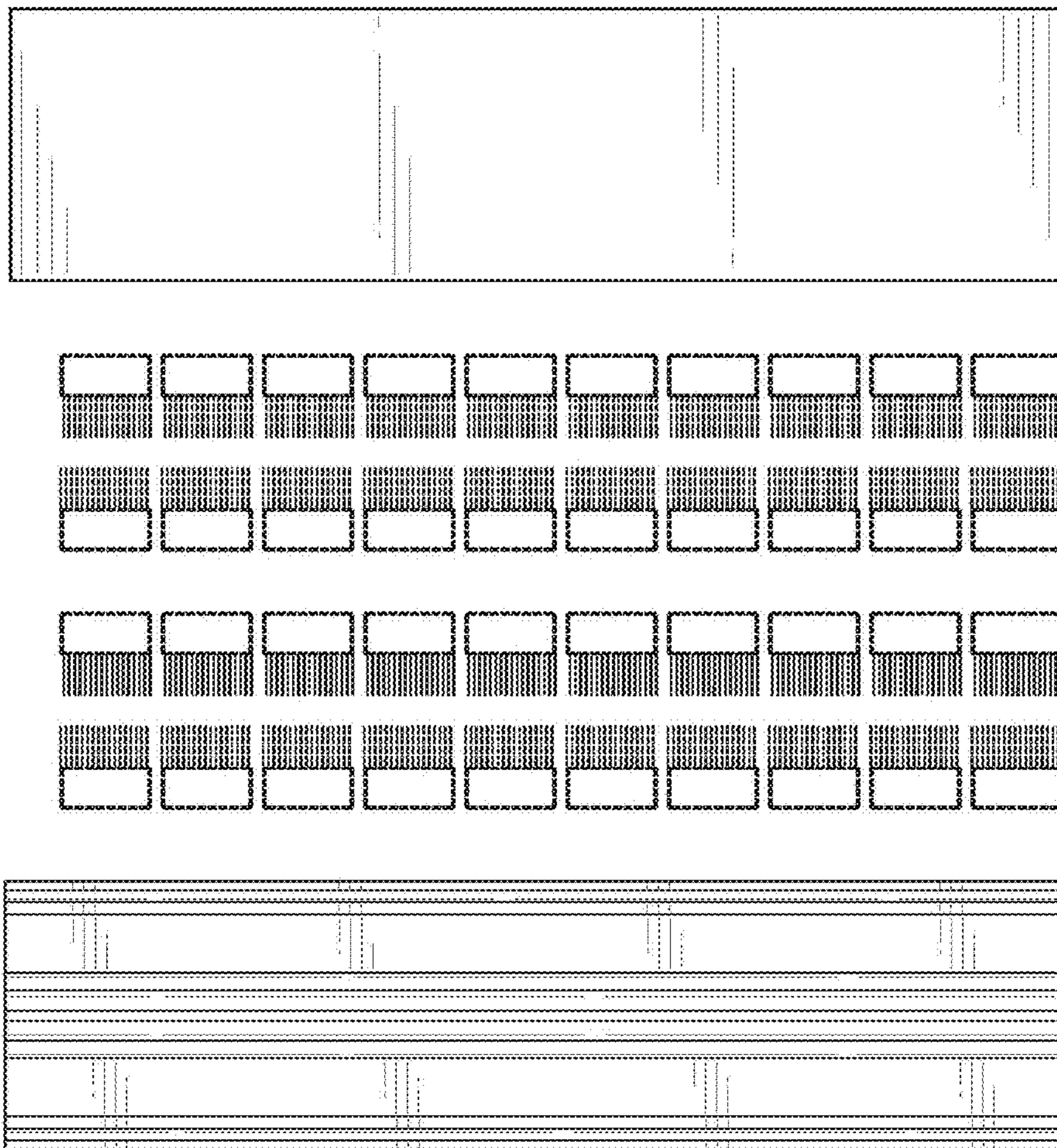

FIG. 5

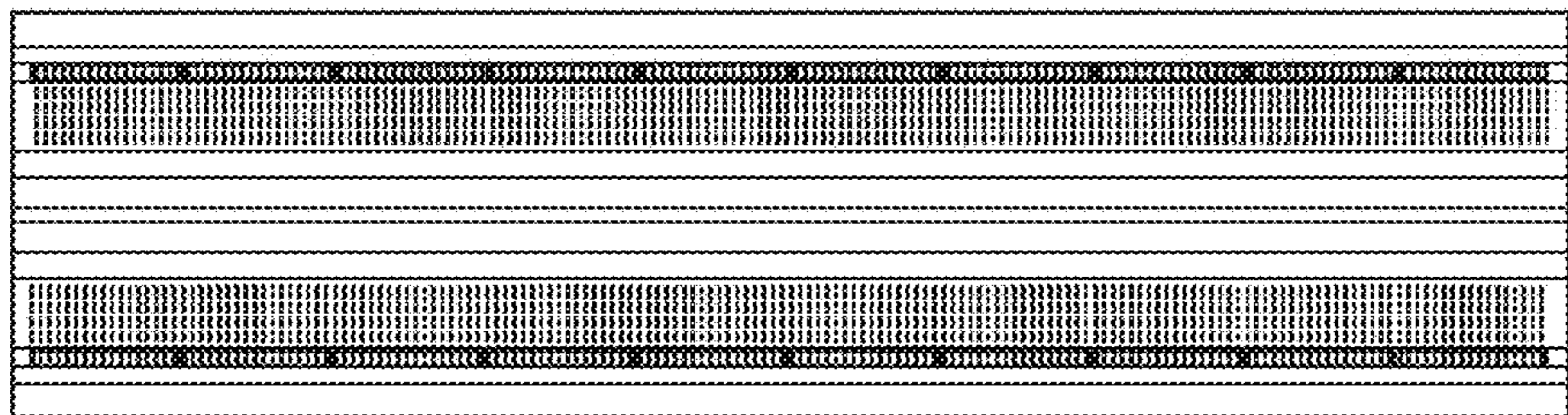

FIG. 6

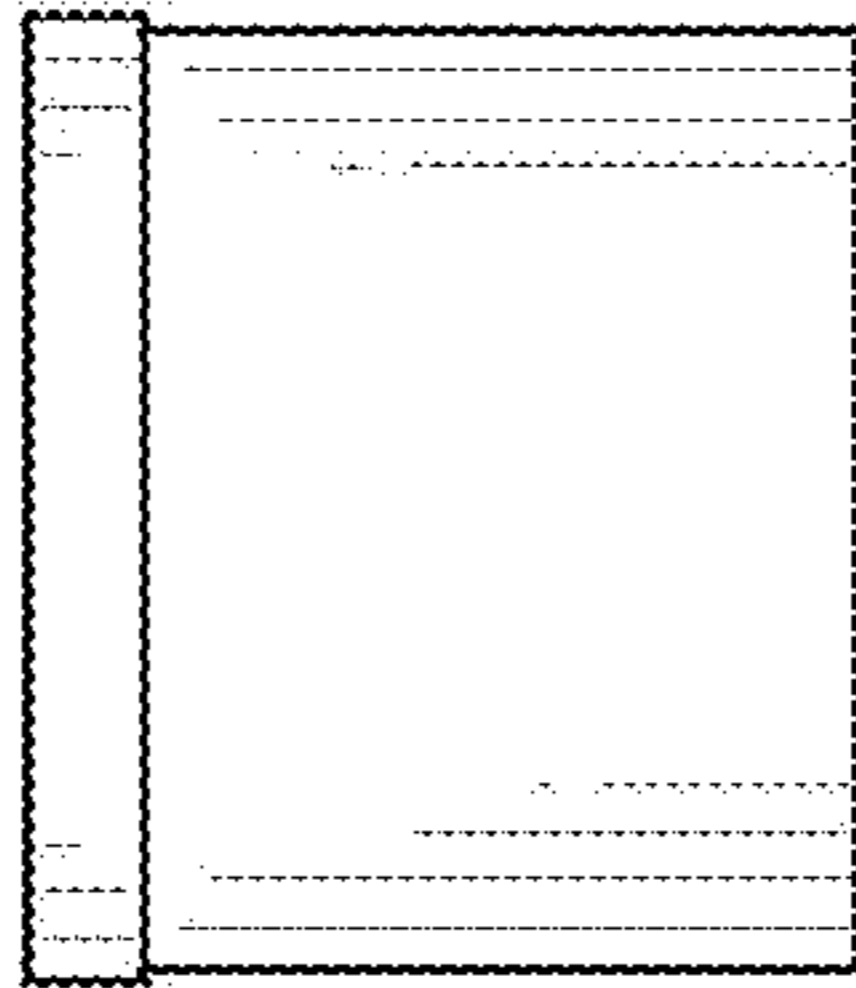

FIG. 8

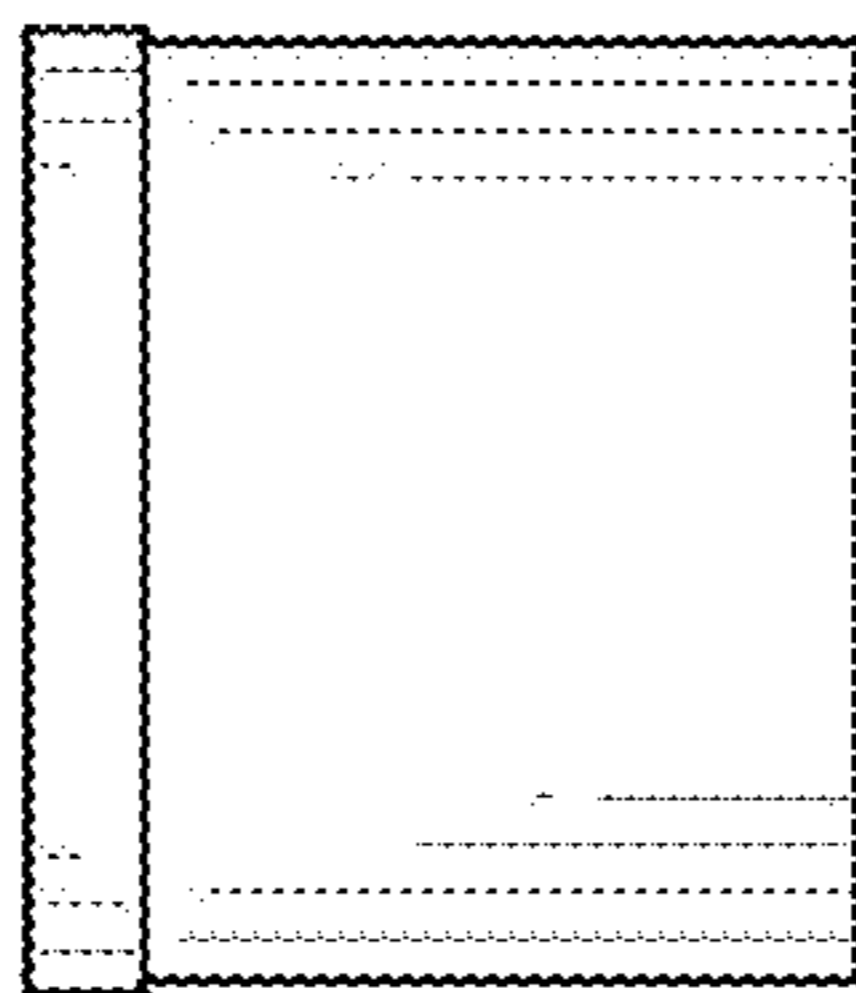

FIG. 7



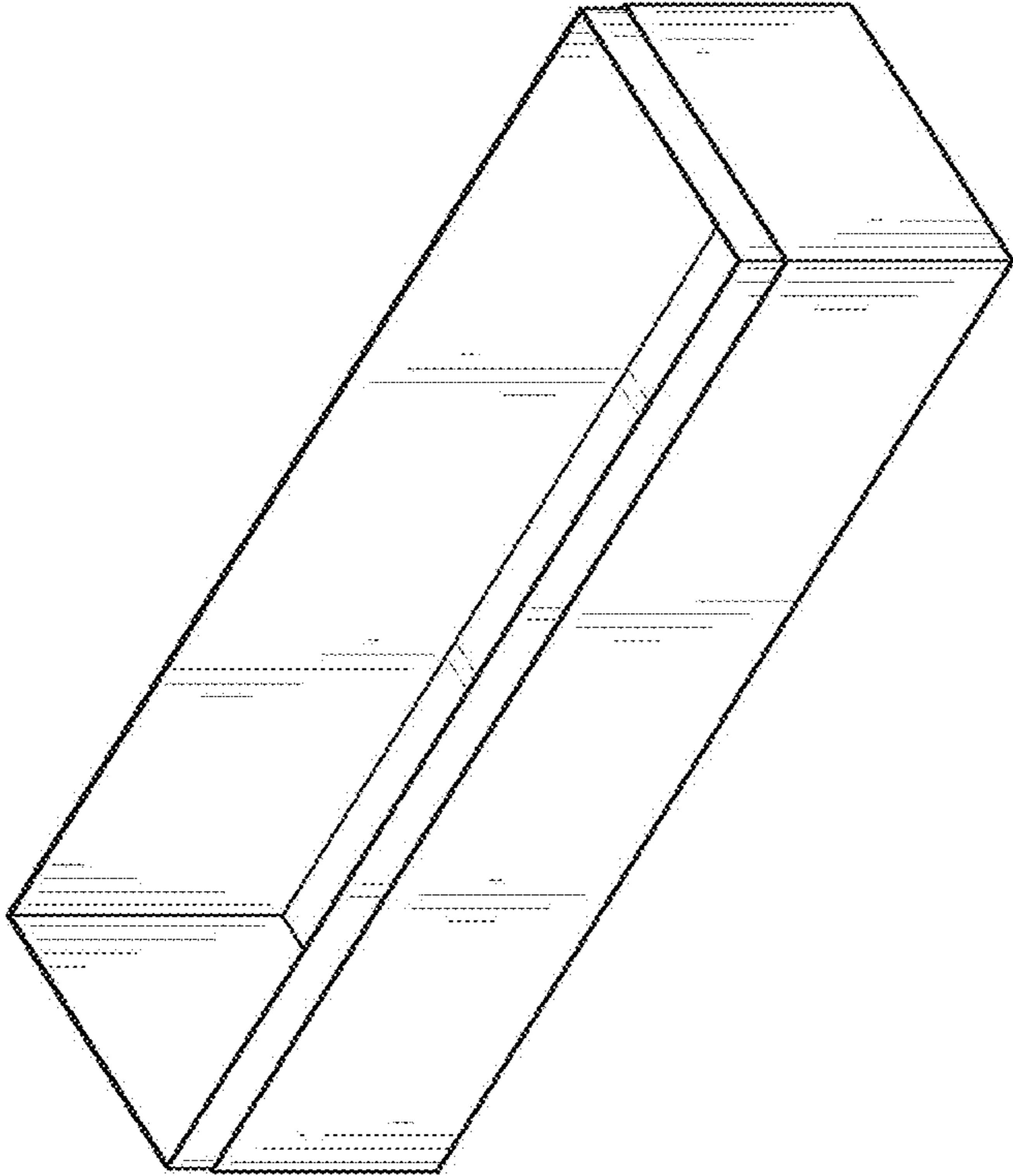

FIG. 9



FIG. 10



FIG. 11

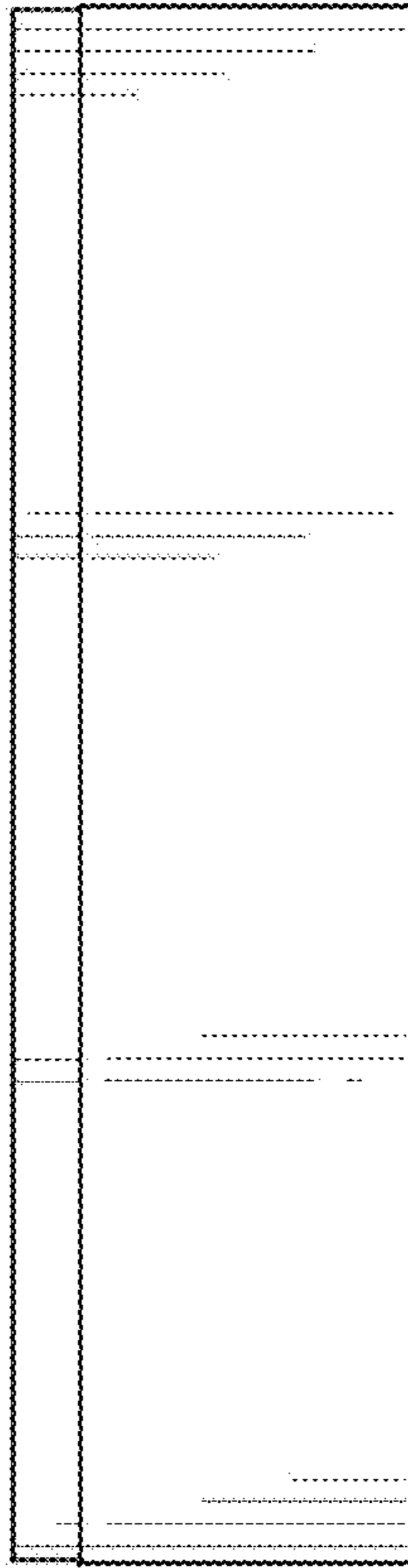

FIG. 12

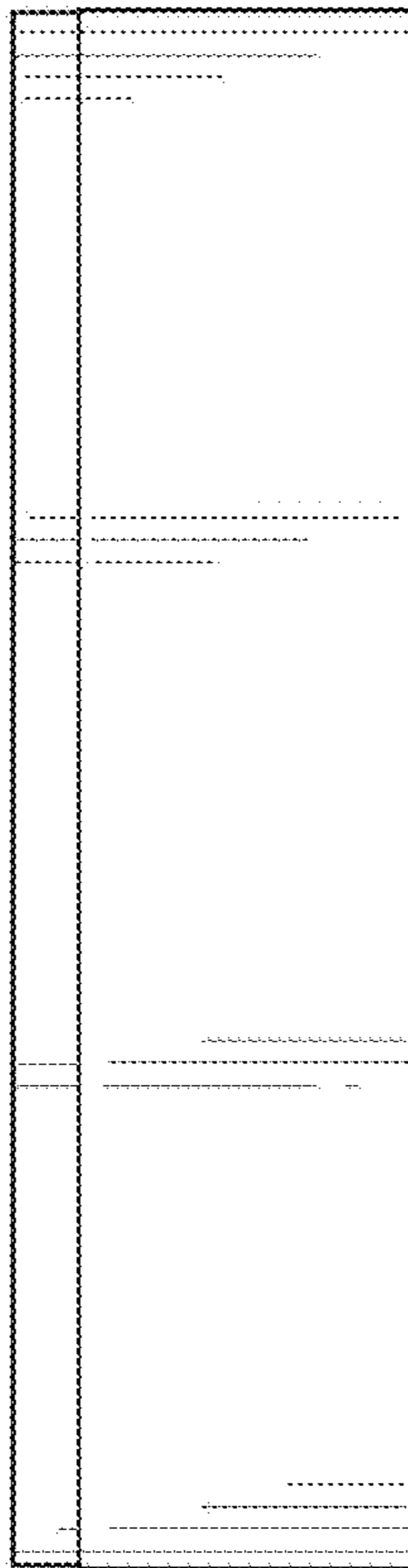

FIG. 13



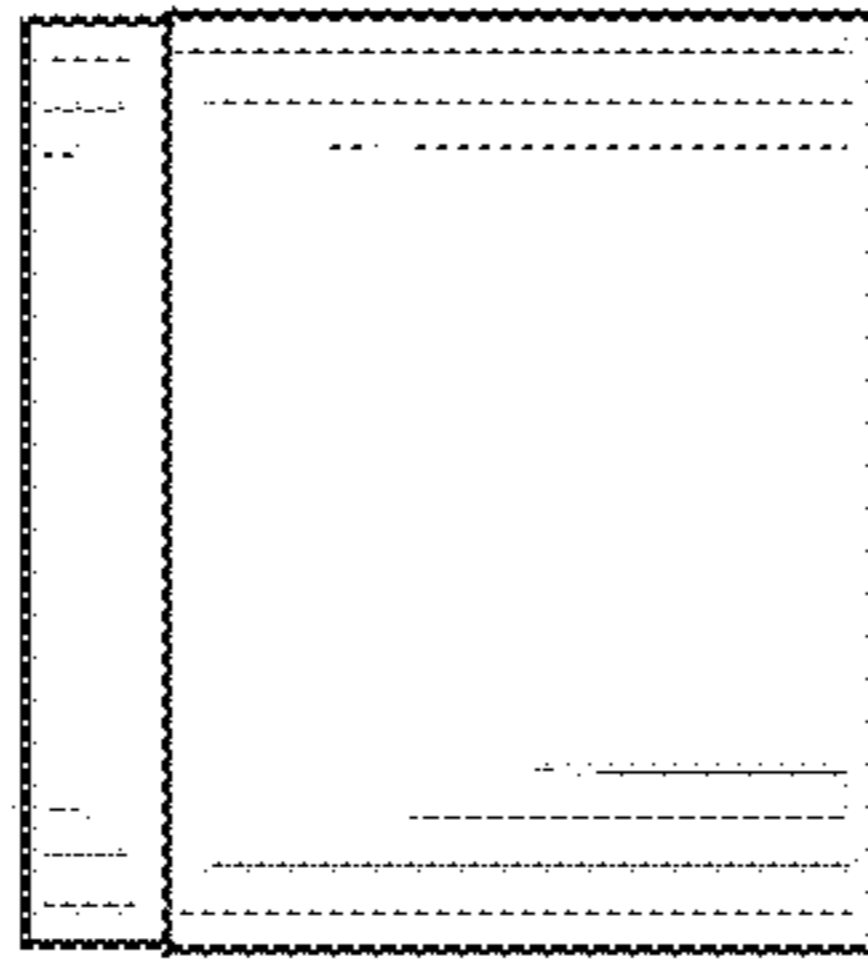

FIG. 14

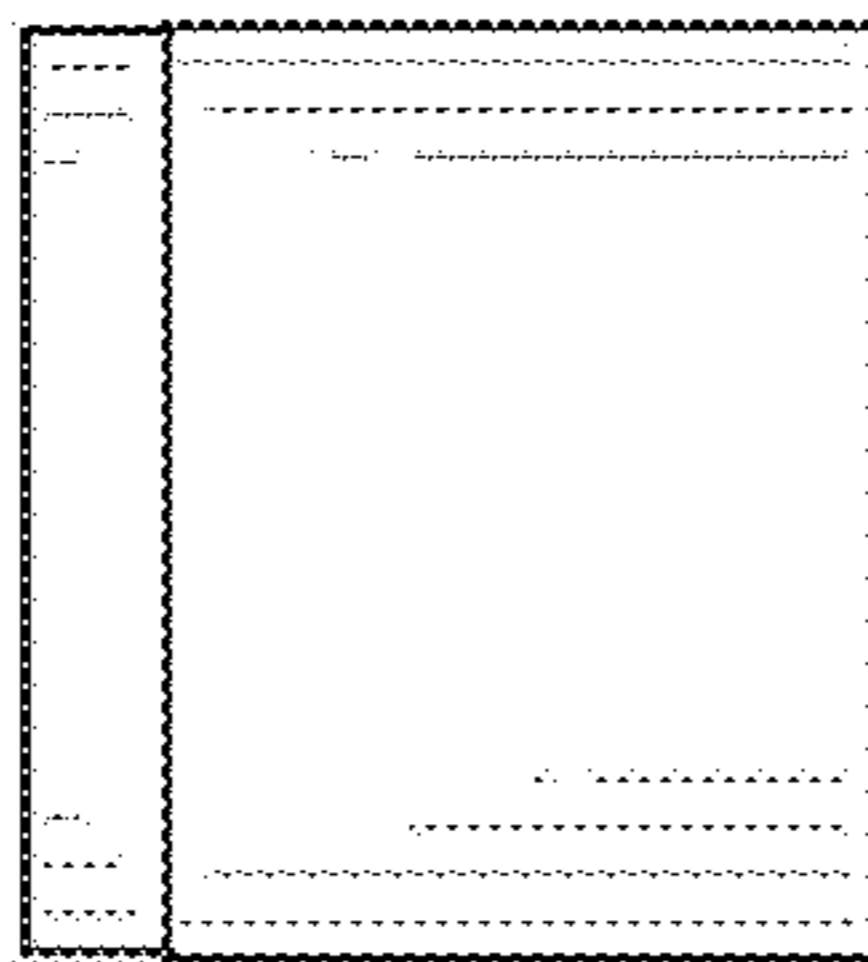

FIG. 15

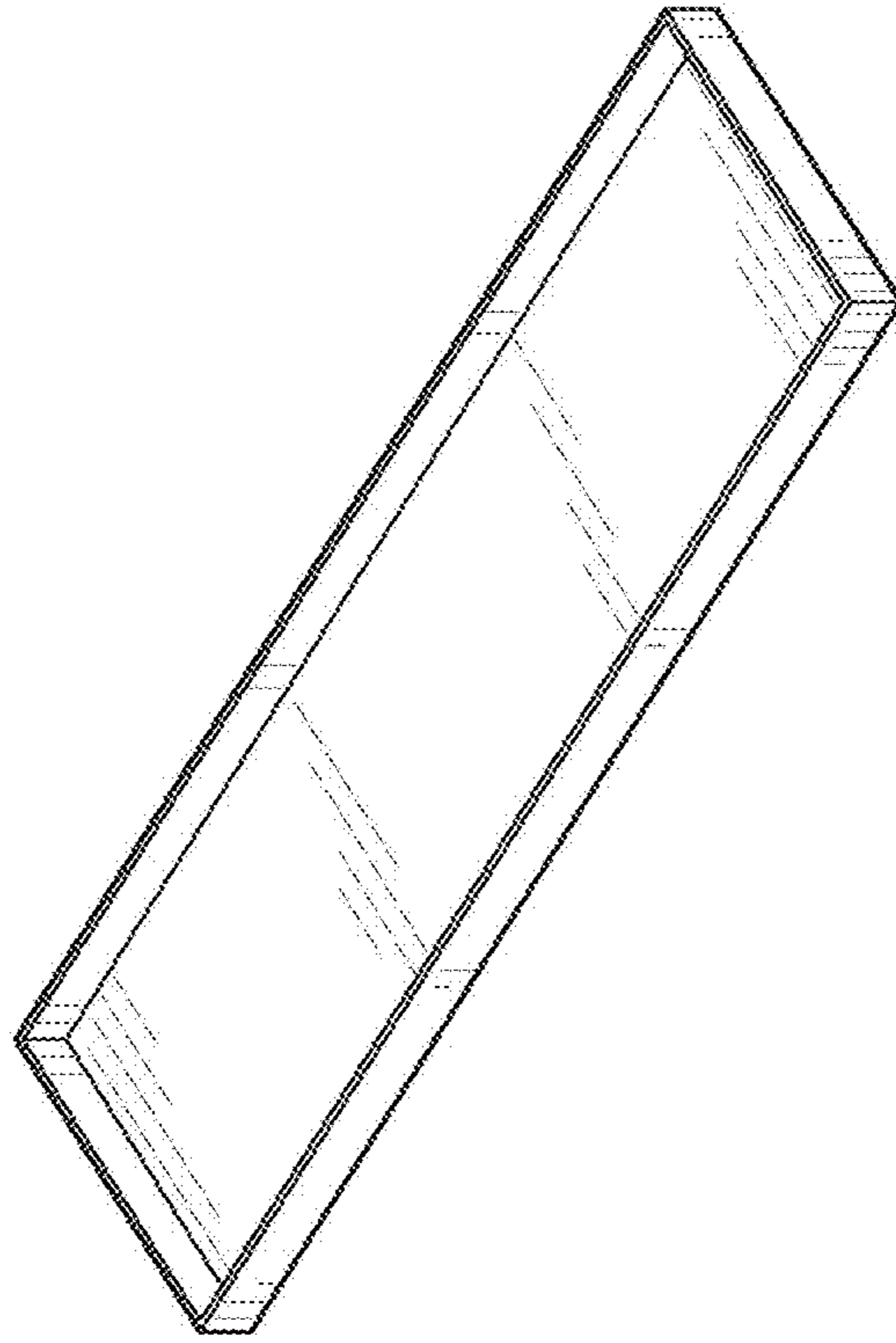

FIG. 16

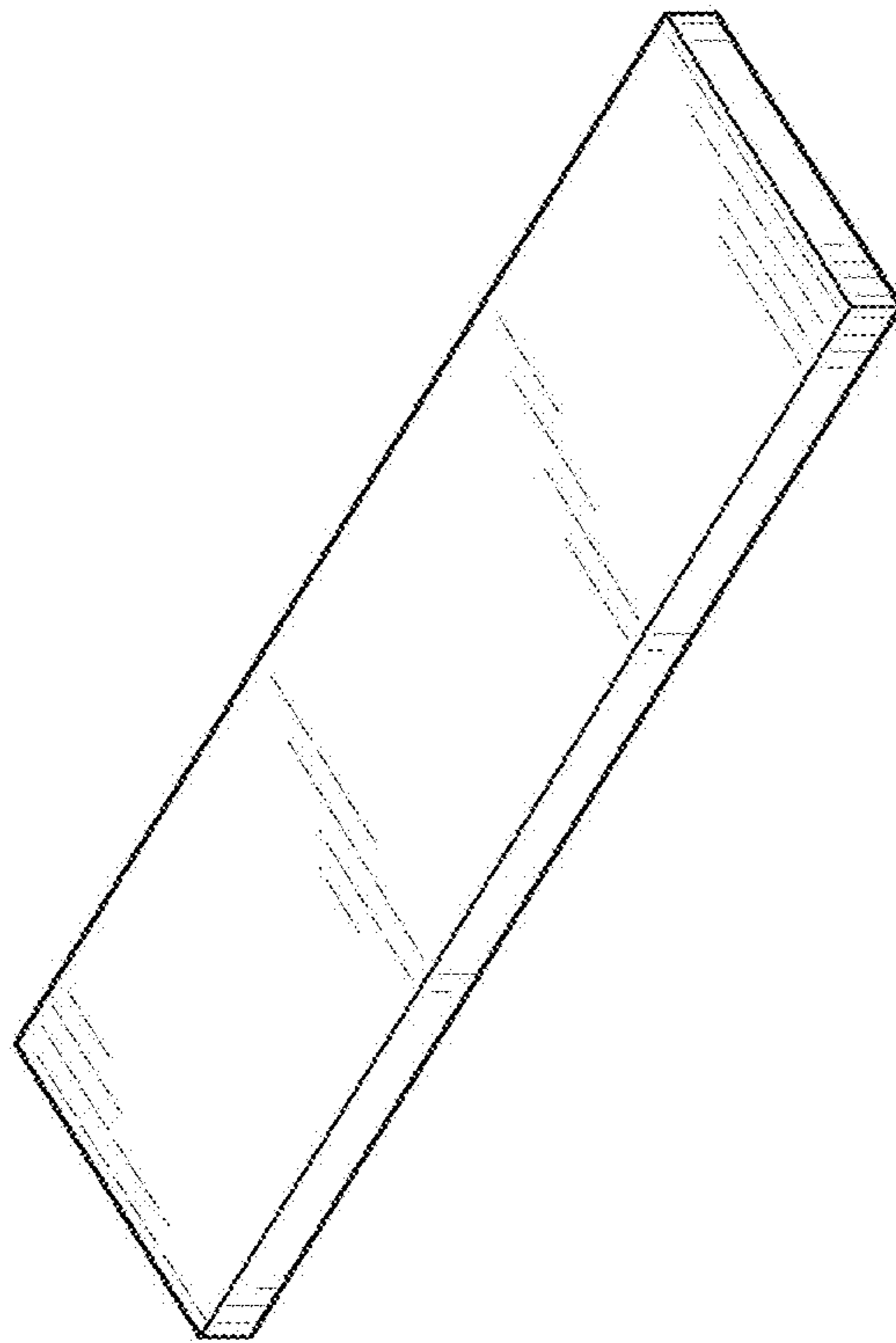

FIG. 17

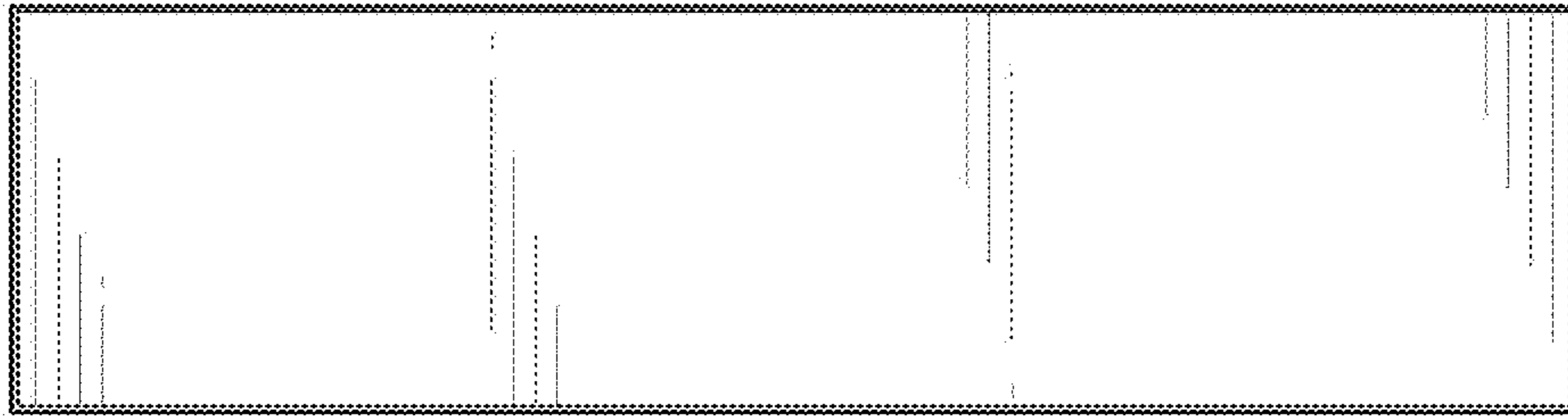

FIG. 19

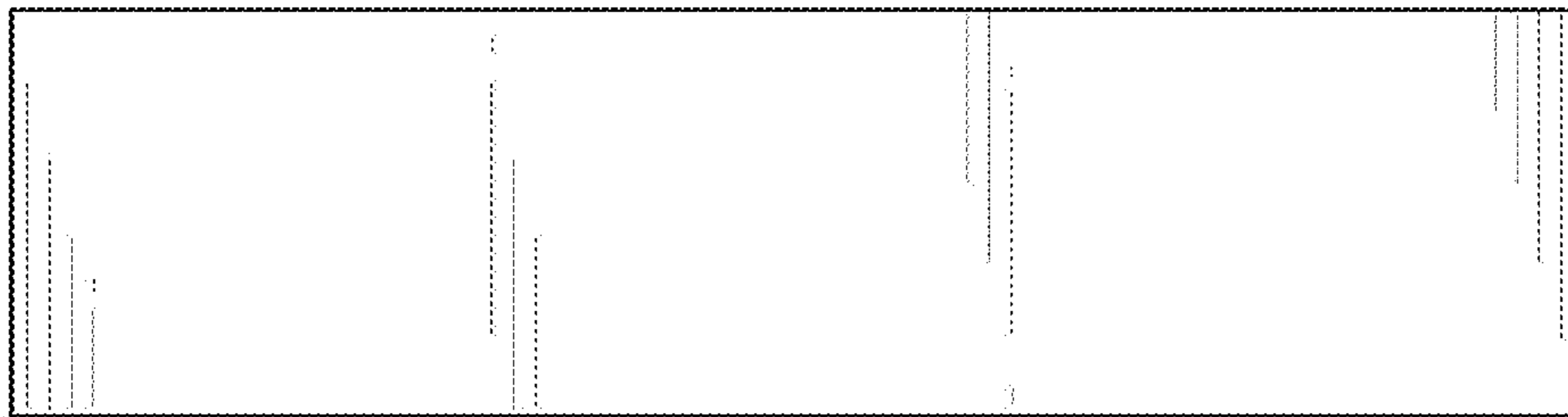

FIG. 18





FIG. 21

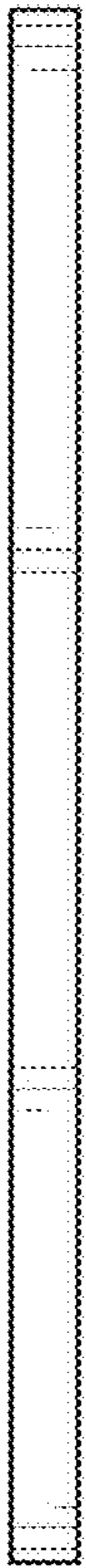

FIG. 20



FIG. 23



FIG. 22

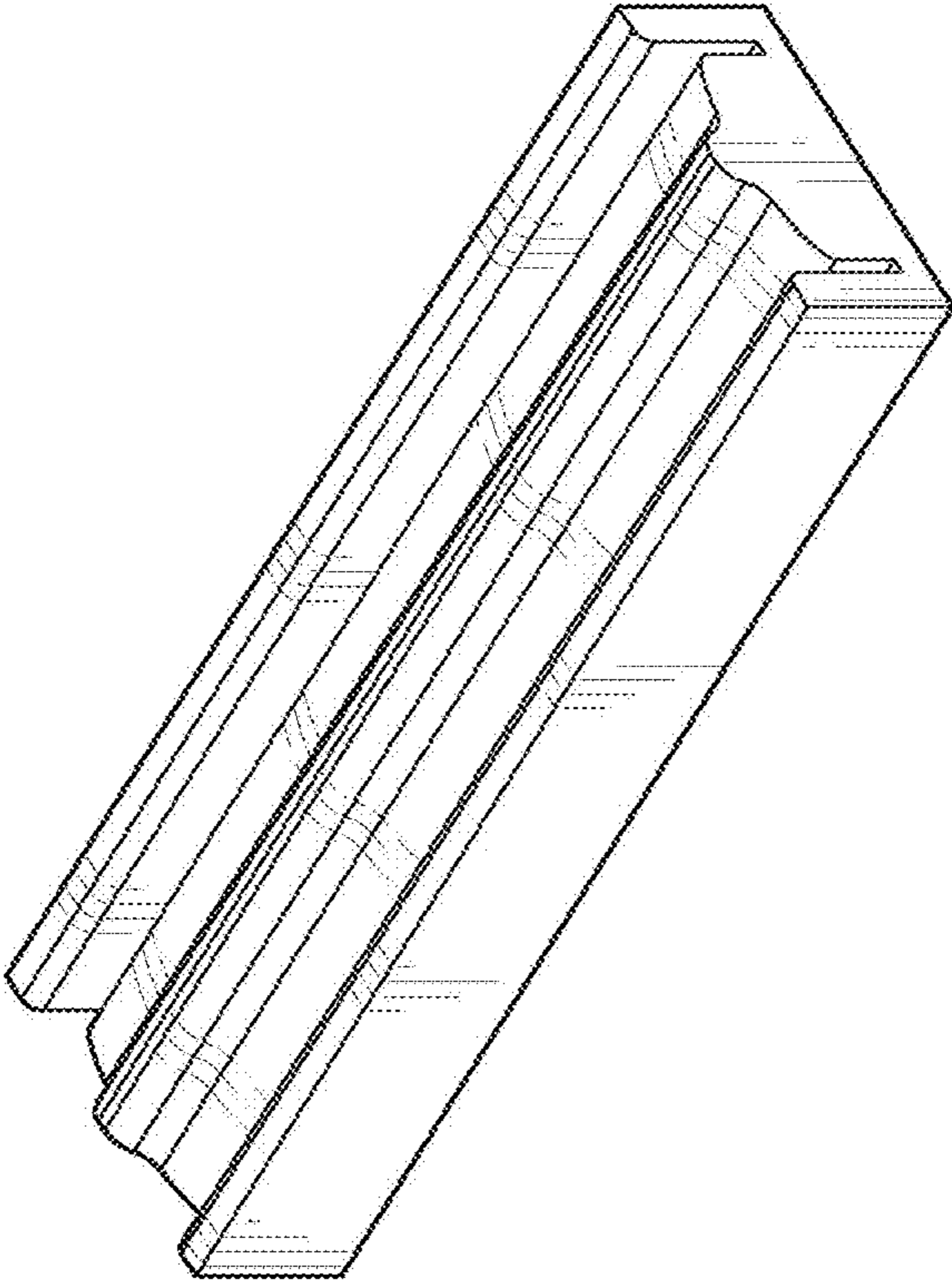

FIG. 24



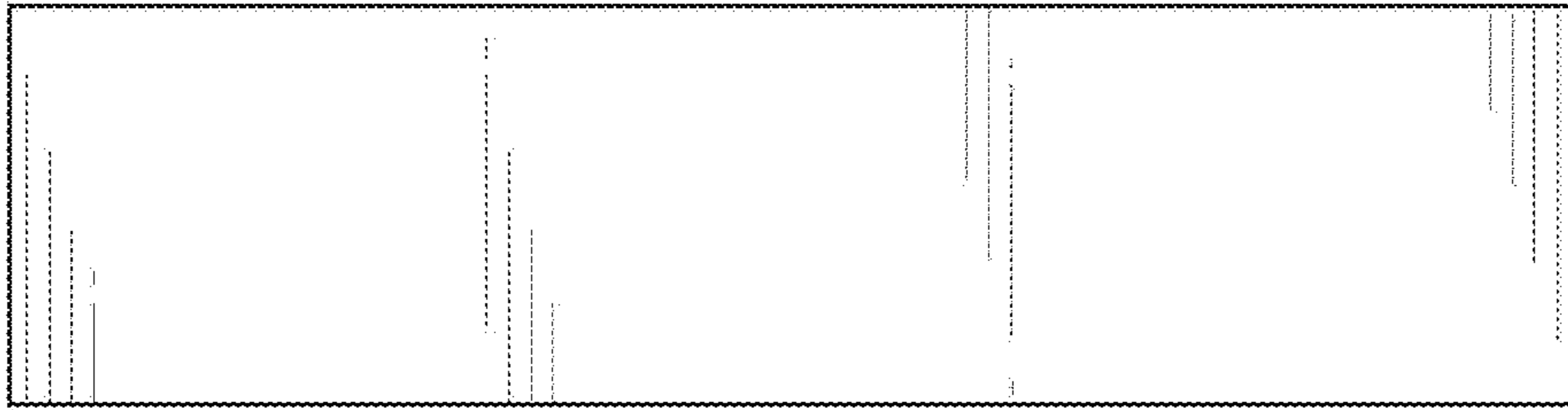

FIG. 26

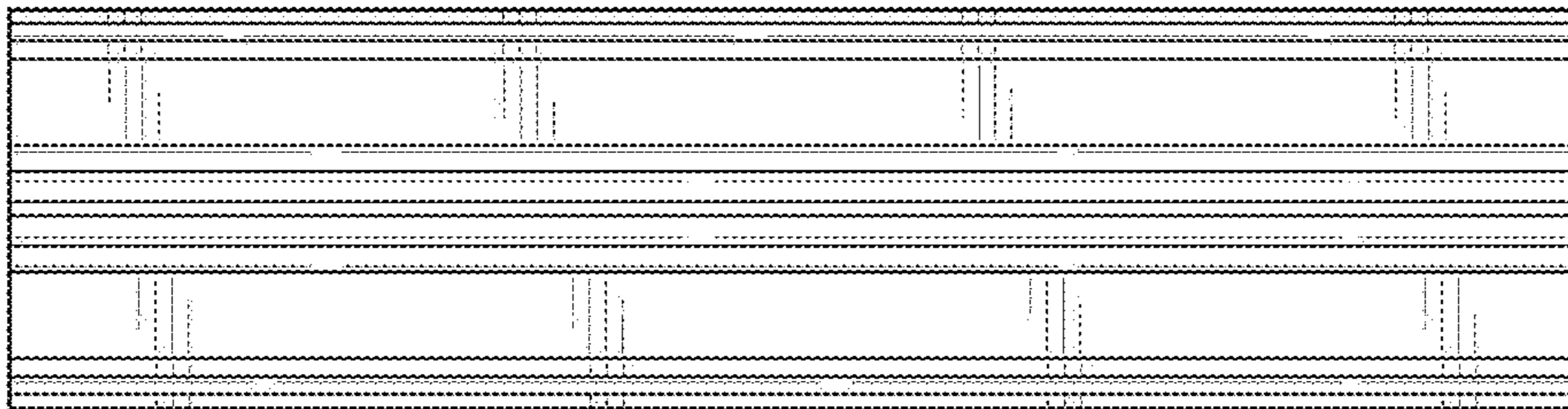

FIG. 25

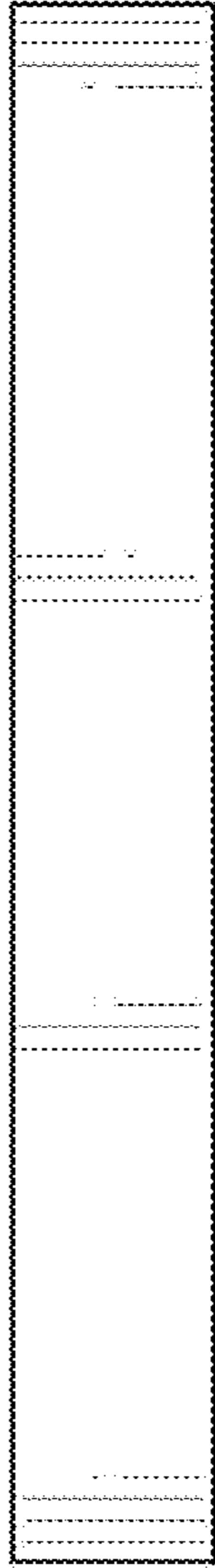

FIG. 27

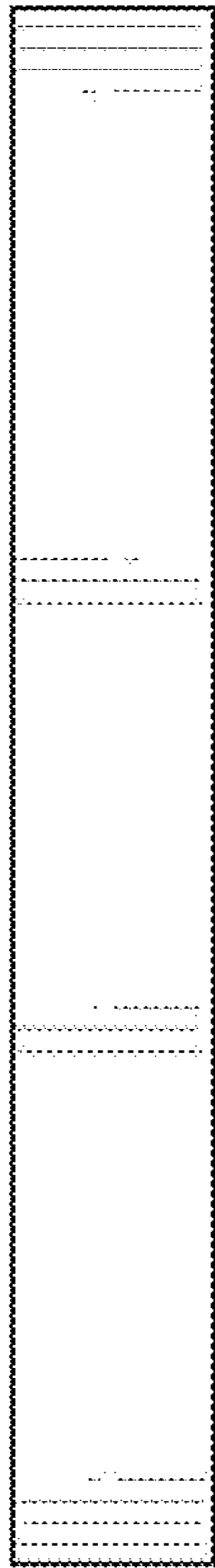

FIG. 28

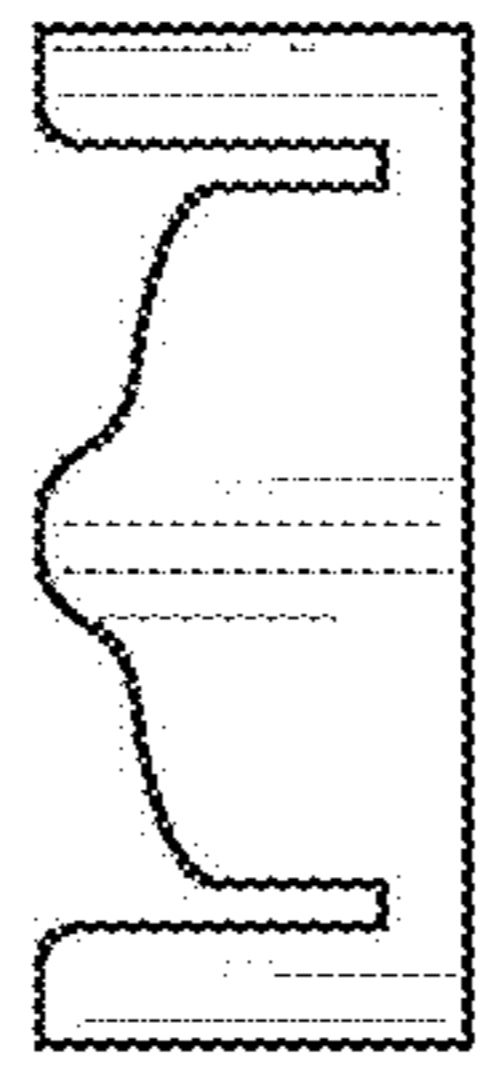

FIG. 29

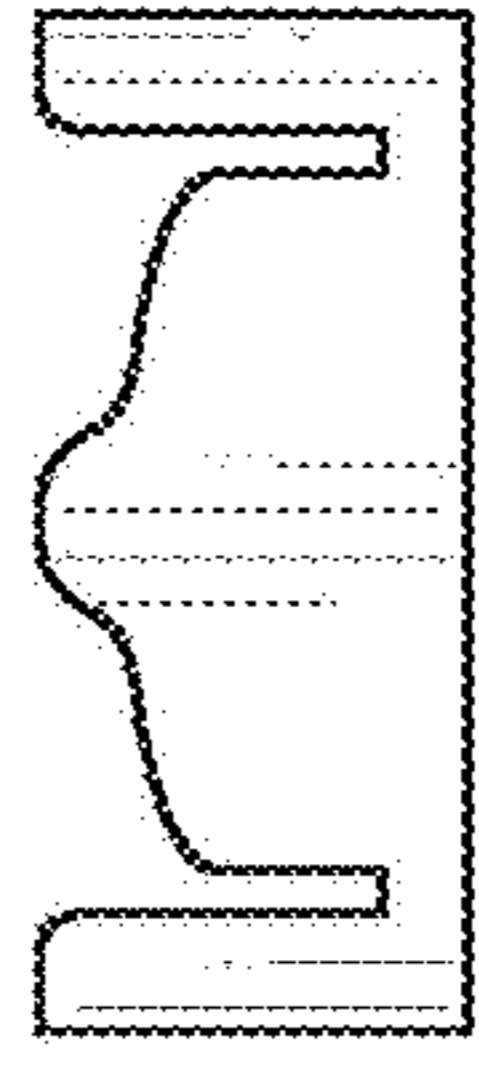

FIG. 30