



US00D787859S

(12) **United States Design Patent**
Goddard

(10) **Patent No.:** **US D787,859 S**

(45) **Date of Patent:** **** May 30, 2017**

(54) **SEAT CUSHION**

(71) Applicant: **Kraco Enterprises, LLC.**, Compton, CA (US)

(72) Inventor: **Lingere D. Goddard**, Fullerton, CA (US)

(73) Assignee: **Kraco Enterprises, LLC.**, Compton, CA (US)

(**) Term: **15 Years**

(21) Appl. No.: **29/591,040**

(22) Filed: **Jan. 16, 2017**

Related U.S. Application Data

(62) Division of application No. 29/549,642, filed on Dec. 28, 2015, now Pat. No. Des. 780,484.

(51) **LOC (10) Cl.** **06-09**

(52) **U.S. Cl.**
USPC **D6/601**

(58) **Field of Classification Search**

USPC D6/333, 349, 355, 375, 388, 512, 563, D6/564, 595, 596, 601, 604, 611, 707, D6/715, 716, 716.1; D24/183-185, 234; D21/803, 804, 805, 809; 5/401, 420, 5/600, 630, 631, 632, 633, 635, 636, 638, 5/639, 646, 652, 652.1, 655, 703, 730; 297/1, 2, 4, 93, 180.11, 195.1, 195.11, 297/195.13, 393, 397, 452.12, 452.14, 297/452.15, 452.21, 452.24, 452.26, 297/452.48, 452.62, 482
CPC A47G 9/10; A47G 9/1009; A47G 9/1018; A47G 9/1027; A47G 9/1036; A47G 9/1045; A47G 9/1063; A47G 9/1072; A47G 9/1081; A47G 9/109; A47C 7/021; A47C 27/00

See application file for complete search history.

(56) **References Cited**

U.S. PATENT DOCUMENTS

D238,235 S *	12/1975	Elgebrandt	5/653
D260,125 S *	8/1981	Rogers	5/653
D316,354 S *	4/1991	Bool	D6/601
D334,318 S *	3/1993	Chee	D6/601
D354,876 S *	1/1995	Pace	D6/596
D386,035 S *	11/1997	Matsler	D6/596
D386,036 S *	11/1997	Laidlaw	D6/601
D396,981 S *	8/1998	Laidlaw	5/654

(Continued)

Primary Examiner — Eric Goodman

Assistant Examiner — Sanjeev Paul

(74) *Attorney, Agent, or Firm* — Wood Herron & Evans LLP

(57) **CLAIM**

The ornamental design for a seat cushion, as shown and described.

DESCRIPTION

FIG. 1 is a front top isometric view of my new seat cushion design;

FIG. 2 is a rear top isometric view thereof;

FIG. 3 is a top view thereof;

FIG. 4 is a bottom view thereof;

FIG. 5 is a right side view thereof;

FIG. 6 is a left side view thereof;

FIG. 7 is a cross-sectional view taken along line 7-7 of FIG. 3;

FIG. 8 is a front view thereof; and,

FIG. 9 is a rear view thereof.

The broken dash line hatching shown in the cross sectional drawing view of FIG. 7 form no part of the claimed design. The broken dash lines shown in the drawing views represent unclaimed portions of the seat cushion, and neither the broken dash lines themselves nor anything within the lines form any part of the claimed design.

1 Claim, 5 Drawing Sheets

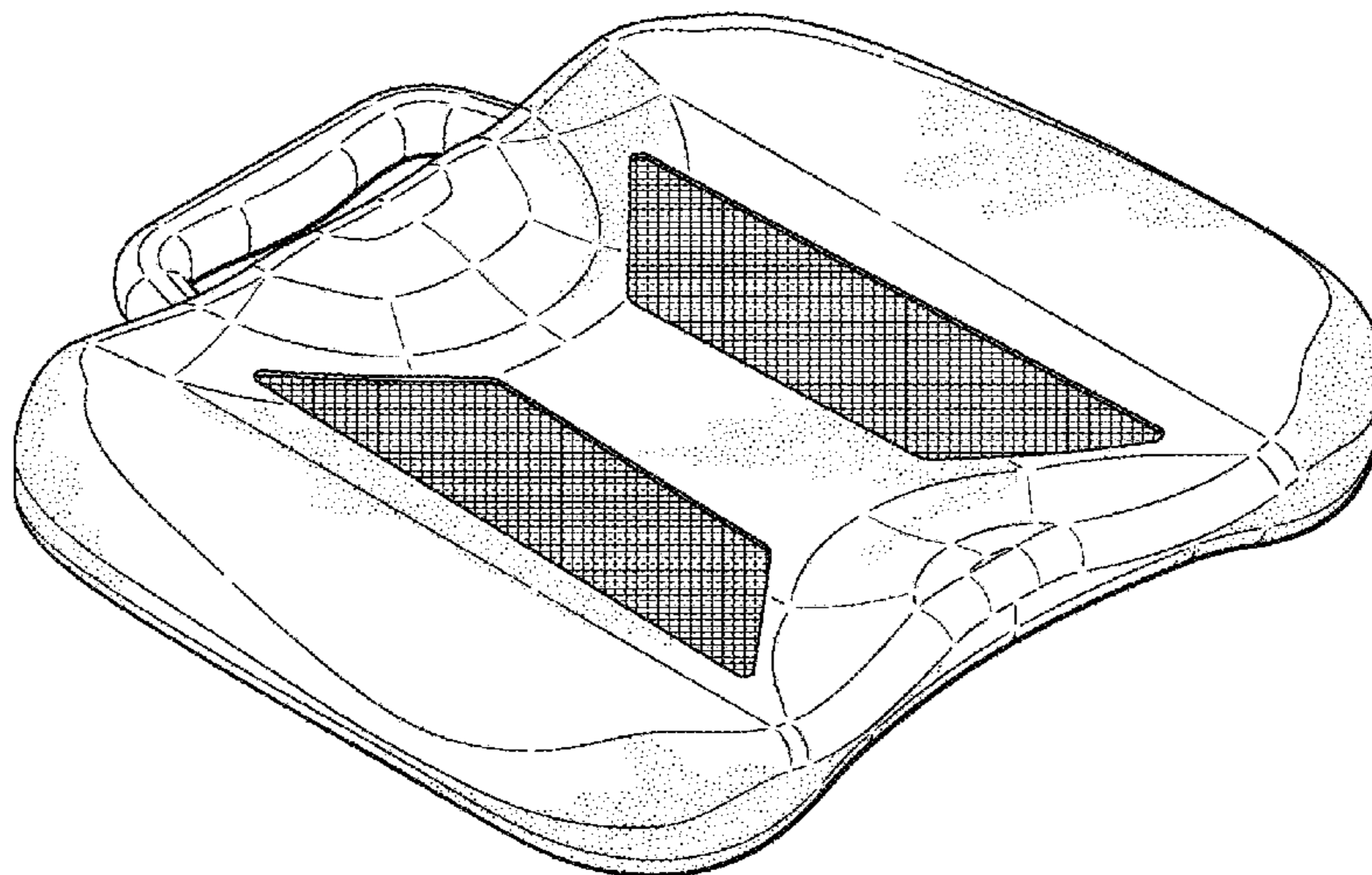

(56)

References Cited

U.S. PATENT DOCUMENTS

D399,694 S *	10/1998	Laidlaw	D6/596	D731,813 S *	6/2015	Durkin	D6/601
D441,588 S *	5/2001	Roberts	D6/601	D732,313 S *	6/2015	Fux	D6/601
D445,505 S *	7/2001	Shapiro	D24/183	D737,075 S *	8/2015	Albrecht	D6/601
D489,113 S *	4/2004	Peterson	D21/803	D747,613 S *	1/2016	Scarlett	D6/601
D496,086 S *	9/2004	Peterson	D21/770	D750,398 S *	3/2016	Werner	D6/601
D496,977 S *	10/2004	Peterson	D21/770	D750,926 S *	3/2016	Line	D6/716.1
7,082,633 B1 *	8/2006	Maarbjerg	A47G 9/10 5/636	D754,990 S *	5/2016	Velasquez	D6/601
D529,324 S *	10/2006	Yates	D6/601	D756,687 S *	5/2016	Durkin	D6/601
D529,325 S *	10/2006	Maarbjerg	D6/601	D759,402 S *	6/2016	Thomas	D6/601
D618,030 S *	6/2010	Wang	D6/601	D779,857 S *	2/2017	Goddard	D6/601
D637,439 S *	5/2011	Mettler	D6/601	D780,484 S *	3/2017	Goddard	D6/601
D637,440 S *	5/2011	Mettler	D6/601	D780,485 S *	3/2017	Goddard	D6/601
D642,846 S *	8/2011	Parish	D6/601	D782,849 *	4/2017	Goddard	D6/601
D707,358 S *	6/2014	Mantilla	D24/184	D782,851 *	4/2017	Goddard	D6/601
D715,579 S *	10/2014	Scarlett	D6/601	2009/0139031 A1 *	6/2009	Davis	A47G 9/10 5/639
D722,449 S *	2/2015	Krishtul	D6/601	2012/0119560 A1 *	5/2012	Wu	A47C 7/022 297/452.21
					2013/0198961 A1 *	8/2013	Davis	A47C 7/62 5/648

* cited by examiner

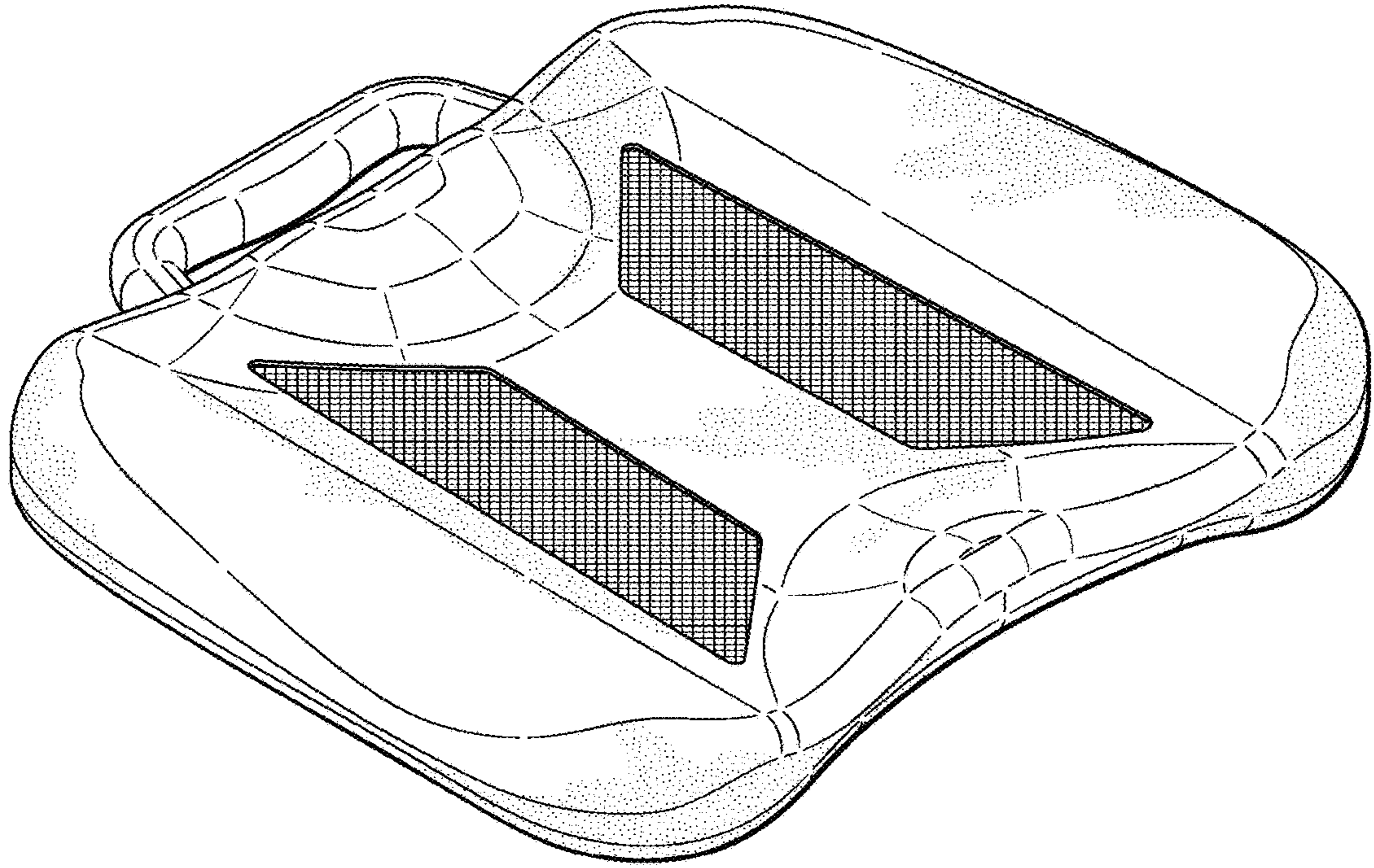

FIG. 1

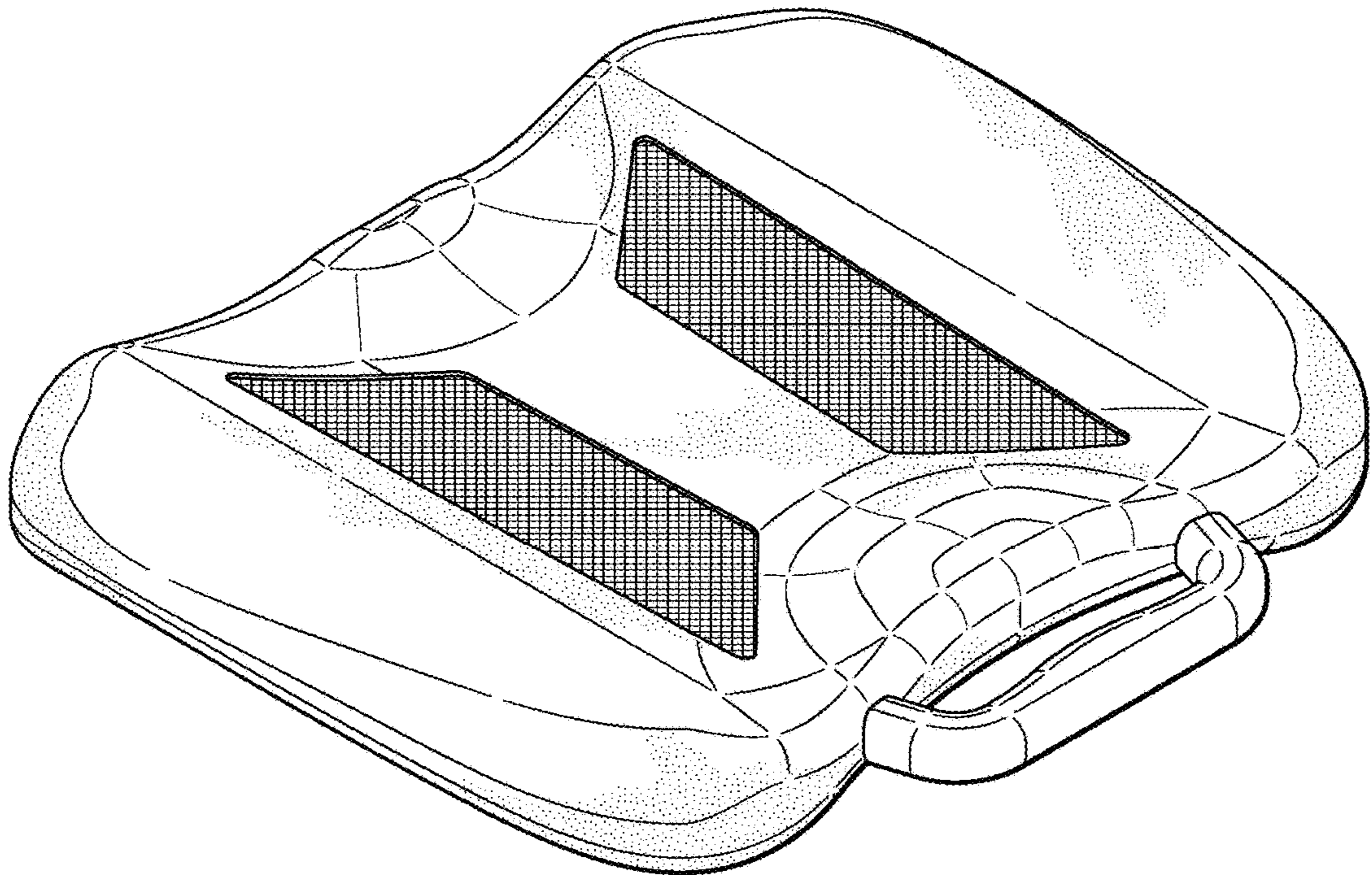

FIG. 2

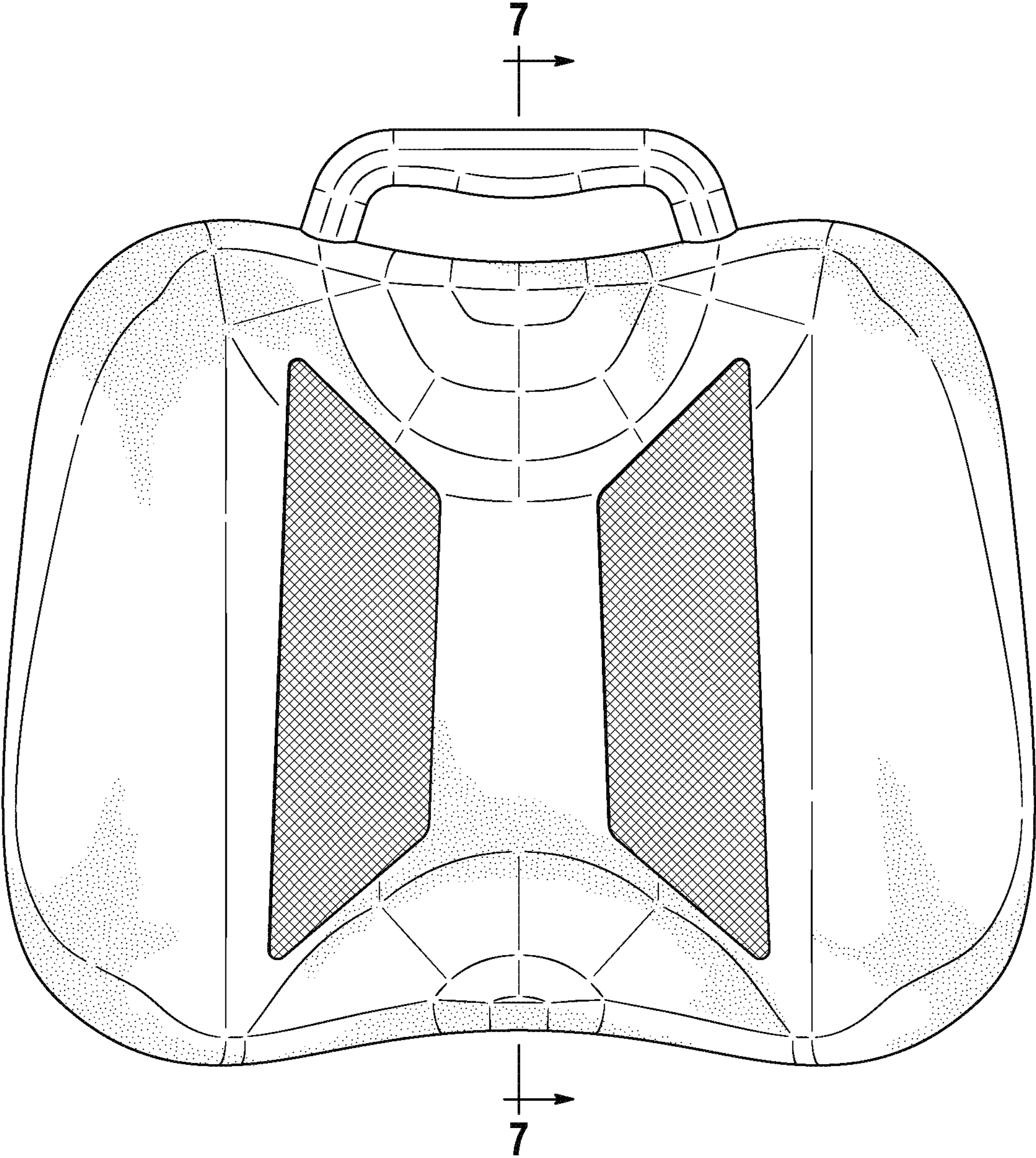

FIG. 3

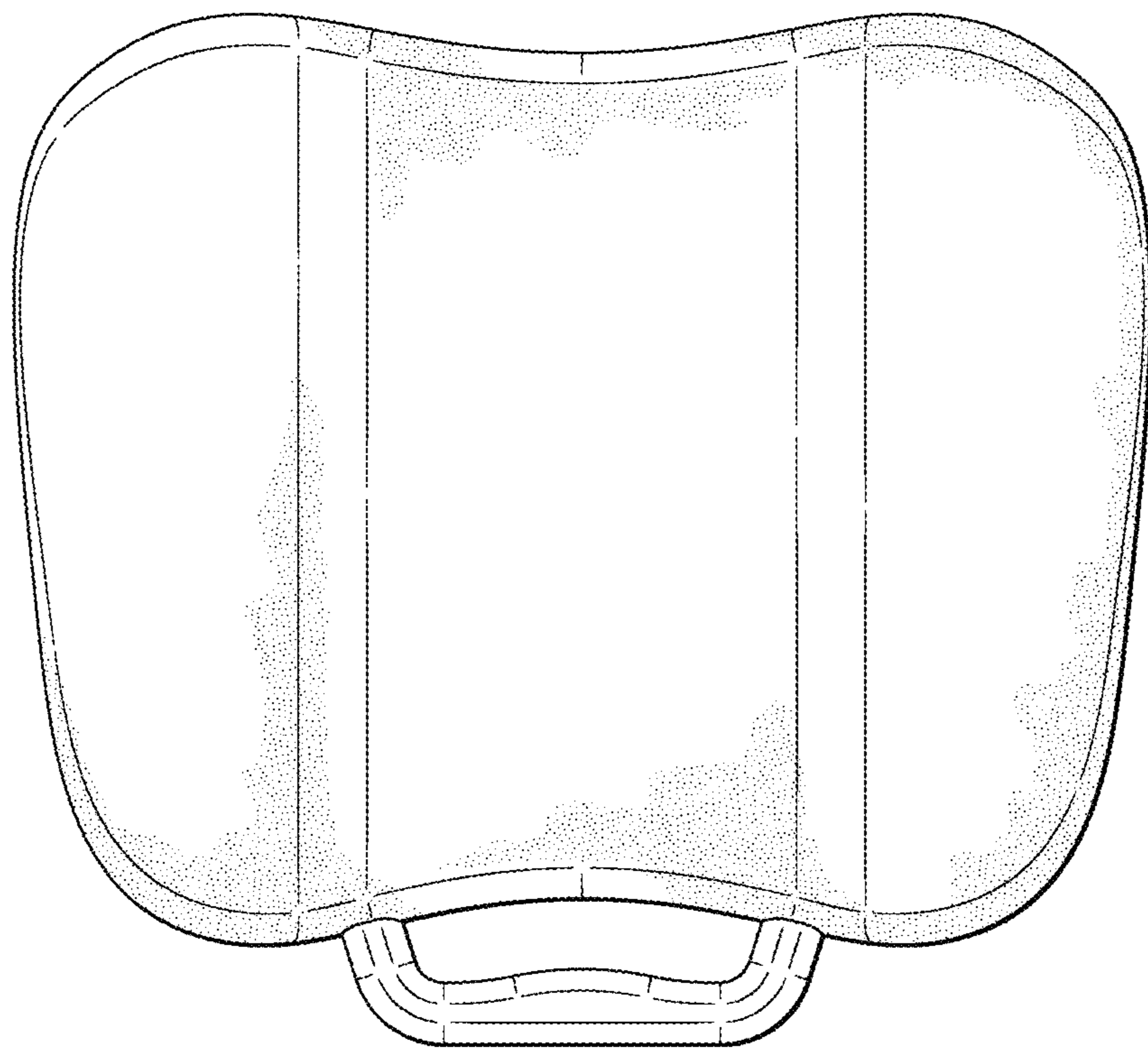

FIG. 4

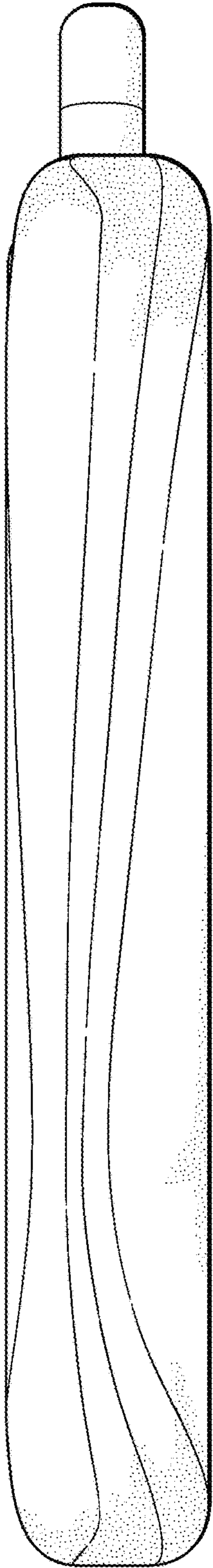

FIG. 5

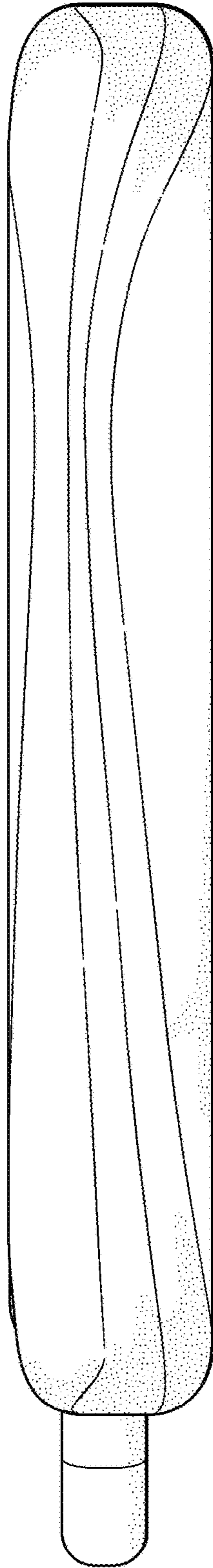

FIG. 6

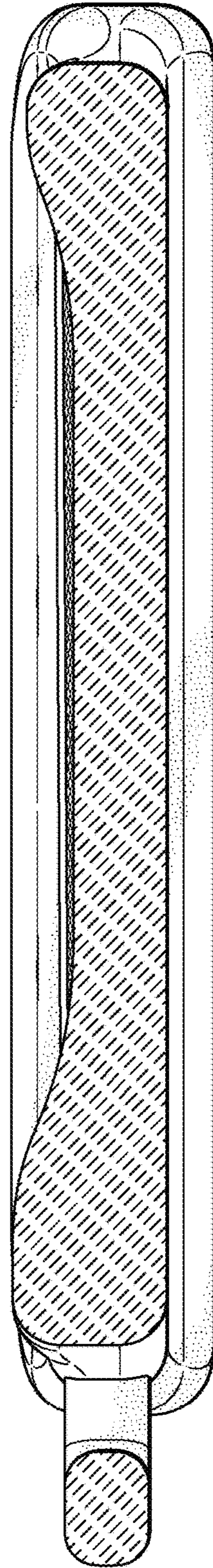

FIG. 7

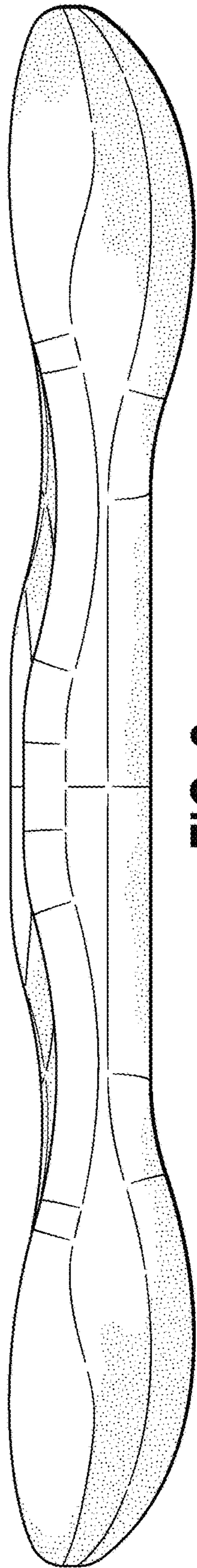

FIG. 8



FIG. 9