



US00D787685S

(12) **United States Design Patent** (10) **Patent No.:** **US D787,685 S**
Vezena (45) **Date of Patent:** **** May 23, 2017**

(54) **PROBE FOR A PERIPHERAL ULTRASOUND DEVICE**

(71) Applicant: **Guardspan Scientific, Inc.**, Park City, UT (US)

(72) Inventor: **Daniel P. Vezena**, Park City, UT (US)

(73) Assignee: **Guardspan Scientific, Inc.**, Park City, UT (US)

(**) Term: **14 Years**

(21) Appl. No.: **29/457,201**

(22) Filed: **Jun. 7, 2013**

(51) **LOC (10) Cl.** **24-01**

(52) **U.S. Cl.**
USPC **D24/187**

(58) **Field of Classification Search**
USPC D24/133, 158, 186-187, 200, 107, 144;
600/437, 439, 446, 453, 459, 463, 424,
600/443; 128/916; D10/60, 80, 103, 78;
73/634
CPC A61B 5/14532; A61B 5/14546; A61B
5/1455; A61B 5/14551; A61B 5/14552;
A61B 7/003; A61B 5/0476; A61B 5/021;
A61B 5/0478; A61B 8/4281; A61B 8/00;
A61B 5/0002; A61B 5/042; A61B 8/12;
C12Q 1/006

See application file for complete search history.

(56) **References Cited**

U.S. PATENT DOCUMENTS

4,165,270 A 8/1979 Ost et al.
4,305,207 A 12/1981 Lantz
4,343,092 A 8/1982 Wahl et al.
4,517,840 A * 5/1985 Thompson G10K 11/004
73/634
4,582,066 A * 4/1986 Barnes A61B 8/065
600/459

4,674,517 A * 6/1987 Barnes G10K 11/004
600/459

4,827,943 A 5/1989 Bornn et al.
4,857,836 A 8/1989 Söelkner
4,908,568 A 3/1990 Söelkner
4,947,853 A 8/1990 Hon
5,022,410 A 6/1991 Hall et al.
5,070,880 A 12/1991 Gomez et al.

(Continued)

FOREIGN PATENT DOCUMENTS

EP 0607490 7/1994
JP 05337108 12/1993

OTHER PUBLICATIONS

Anderson G. Chronic Conditions: Making the Case for Ongoing Care. Johns Hopkins University, Baltimore, MD. Nov. 2007, 77 pages.

(Continued)

Primary Examiner — Ian Simmons
Assistant Examiner — Mark Cavanna
(74) *Attorney, Agent, or Firm* — Polsinelli PC

(57) **CLAIM**

The ornamental design for a probe for a peripheral ultrasound device, as shown and described.

DESCRIPTION

FIG. 1 is a bottom perspective view of a probe for a peripheral ultrasound device showing my new design.
FIG. 2 is a bottom view thereof.
FIG. 3 is a top view thereof.
FIG. 4 is a left view thereof.
FIG. 5 is a right view thereof.
FIG. 6 is a back view thereof; and,
FIG. 7 is a front view thereof.
In the drawings, the broken line showing of cables illustrates environment and forms no part of the claimed design.

1 Claim, 7 Drawing Sheets

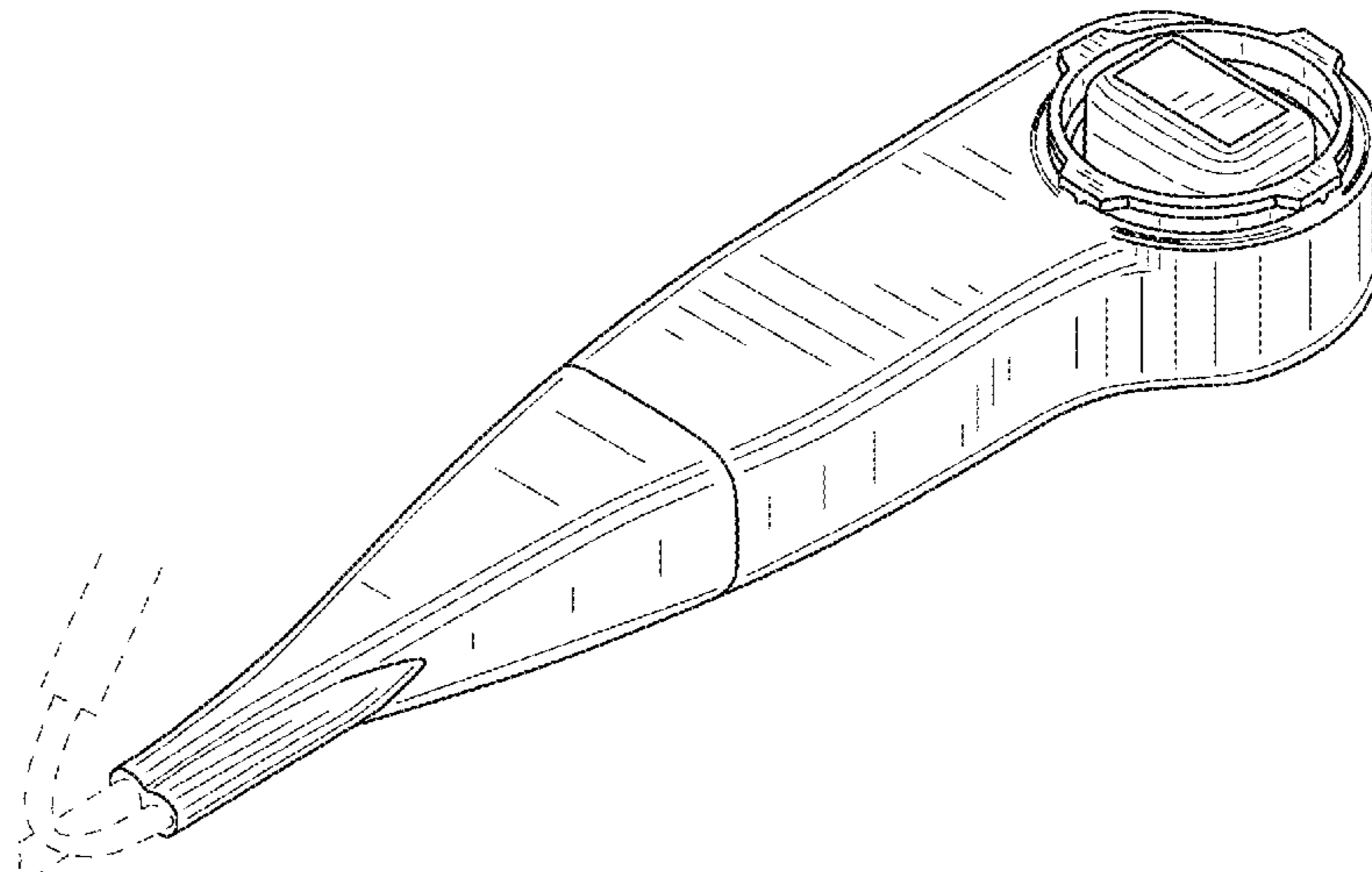

(56)

References Cited

U.S. PATENT DOCUMENTS

| | | | | | |
|--------------|-----|---------|----------------------|-------|------------------------|
| D343,801 | S * | 2/1994 | Burns | | D10/78 |
| 5,394,877 | A | 3/1995 | Orr et al. | | |
| 5,469,852 | A | 11/1995 | Nakamura et al. | | |
| D369,307 | S * | 4/1996 | Imling | | D10/78 |
| 5,558,623 | A * | 9/1996 | Cody | | B06B 1/0269 600/439 |
| 5,598,845 | A | 2/1997 | Chandraratna et al. | | |
| 5,634,468 | A | 6/1997 | Platt et al. | | |
| 5,671,747 | A * | 9/1997 | Connor | | A61B 8/12 600/459 |
| 5,704,352 | A | 1/1998 | Tremblay et al. | | |
| 5,740,804 | A | 4/1998 | Cerofolini | | |
| 5,771,896 | A | 6/1998 | Sliwa, Jr. et al. | | |
| 5,807,268 | A | 9/1998 | Reeves et al. | | |
| 5,947,961 | A | 9/1999 | Netherly | | |
| 6,031,383 | A | 2/2000 | Streib et al. | | |
| D425,980 | S * | 5/2000 | Last | | D24/107 |
| 6,124,723 | A | 9/2000 | Costello | | |
| 6,126,636 | A | 10/2000 | Naka | | |
| 6,132,371 | A | 10/2000 | Dempsey et al. | | |
| 6,139,502 | A * | 10/2000 | Fredriksen | | A61B 8/4281 600/459 |
| 6,248,101 | B1 | 6/2001 | Whitmore, III et al. | | |
| 6,261,231 | B1 | 7/2001 | Damphousse et al. | | |
| 6,285,180 | B1 | 9/2001 | Pas | | |
| 6,577,893 | B1 | 6/2003 | Besson et al. | | |
| 6,653,825 | B2 | 11/2003 | Munniksma | | |
| D536,450 | S * | 2/2007 | Ryan | | D24/144 |
| 7,215,991 | B2 | 5/2007 | Besson et al. | | |
| 7,244,230 | B2 | 7/2007 | Duggirala et al. | | |
| D550,365 | S * | 9/2007 | Kitayama | | D24/186 |
| D623,755 | S * | 9/2010 | Ikegame | | D24/186 |
| D638,946 | S * | 5/2011 | Egorov | | D24/187 |
| 8,348,847 | B2 | 1/2013 | Vezina | | |
| D687,153 | S * | 7/2013 | Torzilli | | D24/187 |
| 2002/0120310 | A1 | 8/2002 | Linden et al. | | |
| 2003/0187362 | A1 | 10/2003 | Murphy et al. | | |
| 2003/0220578 | A1 | 11/2003 | Ho et al. | | |
| 2004/0006278 | A1 | 1/2004 | Webb et al. | | |
| 2004/0015081 | A1 | 1/2004 | Kramer et al. | | |
| 2005/0157888 | A1 | 7/2005 | Yang | | |
| 2005/0232434 | A1 | 10/2005 | Andersen | | |
| 2005/0288584 | A1 | 12/2005 | McMorrow et al. | | |
| 2006/0030782 | A1 | 2/2006 | Shennib | | |
| 2006/0241464 | A1 | 10/2006 | Ohtake et al. | | |
| 2006/0264767 | A1 | 11/2006 | Shennib | | |
| 2007/0106751 | A1 | 5/2007 | Moore | | |
| 2007/0260285 | A1 | 11/2007 | Libbus et al. | | |
| 2007/0261493 | A1 | 11/2007 | Kim | | |
| 2007/0276251 | A1 | 11/2007 | Orenstein et al. | | |
| 2007/0276270 | A1 | 11/2007 | Tran | | |
| 2008/0004904 | A1 | 1/2008 | Tran | | |
| 2008/0013747 | A1 | 1/2008 | Tran | | |
| 2010/0168577 | A1 | 7/2010 | Vezina | | |
| 2011/0270089 | A1 | 11/2011 | Vezina | | |
| 2013/0102899 | A1 | 4/2013 | Vezina | | |
| 2013/0102900 | A1 | 4/2013 | Vezina | | |

OTHER PUBLICATIONS

Devereux et al. A population-based assessment of left ventricular systolic dysfunction in middle-aged and older adults; the Strong Heart Study. *Am Heart J.* Mar. 2001 141(3): 439-46.

Devereux et al. Congestive heart failure despite normal ventricular systolic function in a population-based sample: the Strong Heart Study. *Am. J. Cardiol.* Nov. 15, 2000; 86 (10): 1090-6.

Eagle et al. ACC/AHA Guideline Update for Perioperative Cardiovascular Evaluation for Noncardiac Surgery-Executive Summary. A report of the American College of Cardiology/American Heart Association Task Force on Practice Guidelines (Committee to Update the 1996 Guidelines on Perioperative Cardiovascular Evaluation for Noncardiac Summary) *Anesth. Analg.* May 4/5, 2002) 1052-64.

Garrett et al. The boomers are coming; a total cost of care model of the impact of population aging on the cost of chronic conditions in the United States. *Dis Manag.* Apr. 2007; 10(2): 51-60.

Hammill et al. Impact of heart failure on patients undergoing major noncardiac surgery. *Anesthesiology*, 2008; 108:559-567.

International Search Report and Written Opinion, PCT/US2009/052850, Sep. 29, 2009, 11 pages.

International Search Report and Written Opinion, PCT/US2009/069474, 10 pages, Feb. 25, 2010.

Jencks et al. Rehospitalizations among patients in the Medicare fee-for-service program. *N Engl J Med* 2009;360:1418-28.

Maurer et al. Ventricular structure and function in hypertensive participants with heart failure and a normal ejection fraction; the Cardiovascular Health Study. *J. Am. Col. Cardiol.* Mar. 6, 2007; 49(9): 982-85.

Non-Final Office Action, U.S. Appl. No. 12/536,247, mailed Feb. 16, 2012, 24 pages.

Notice of Allowance, U.S. Appl. No. 12/536,247, mailed Sep. 18, 2012, 8 pages.

Owings et al. Ambulatory and Inpatient procedures in the United States, 1996. National Center for Health Statistics. *Vital Health Stat* 13(139), 1998.

Pelletier et al. Increasing US Emergency Department Visit Rates and Subsequent Hospital Admissions for Atrial Fibrillation from 1993 to 2004. *Ann. Emerg Med.* Jan. 2008;51(1):58-65.

Polanczyk et al. Right heart catheterization and the cardiac complications in patients undergoing noncardiac surgery: An observational study. *JAMA* 2001; 286: 309-314.

Practice Guidelines for Transesophageal Echocardiography. A report by the American Society of Anesthesiologists and the Society of Cardiovascular Anesthesiologists Task Force on Transesophageal Echocardiography. *Anesthesiology*. 1996: 986-1006.

Redfield et al. Burden of systolic and diastolic ventricular dysfunction in the community: appreciating the scope of the heart failure epidemic. *JAMA*, 2003; 289: 194-202.

Response to Non-Final Office Action, U.S. Appl. No. 12/536,247, filed Jun. 15, 2012, 12 pages.

Sandham et al. A randomized, controlled trial of the use of pulmonary-artery catheters in high-risk surgical patients. *N Engl J. Med.* vol. 348, No. 1, Jan. 2, 2003.

Standards for Basic Anesthetic Monitoring (Approved by the ASA House of Delegates on Oct. 21, 1986, and last amended on Oct. 25, 2005). [Http://www.asahg.org/publicationsAndServices/standards/02.pdf](http://www.asahg.org/publicationsAndServices/standards/02.pdf) last accessed Mar. 12, 2008.

U.S. Census Bureau. U.S. Interim Projections by Age, Sex, Race, and Hispanic Origin. [Http://www.census.gov/pc/www/usinterimproj/](http://www.census.gov/pc/www/usinterimproj/) Mar. 18, 2004. Last accessed Mar. 12, 2008.

U.S. Appl. No. 29/457,196, filed Jun. 7, 2013, Vezina.

U.S. Appl. No. 29/457,200, filed Jun. 7, 2013, Vezina.

U.S. Appl. No. 13/912,763, filed Jun. 7, 2013, Vezina.

* cited by examiner

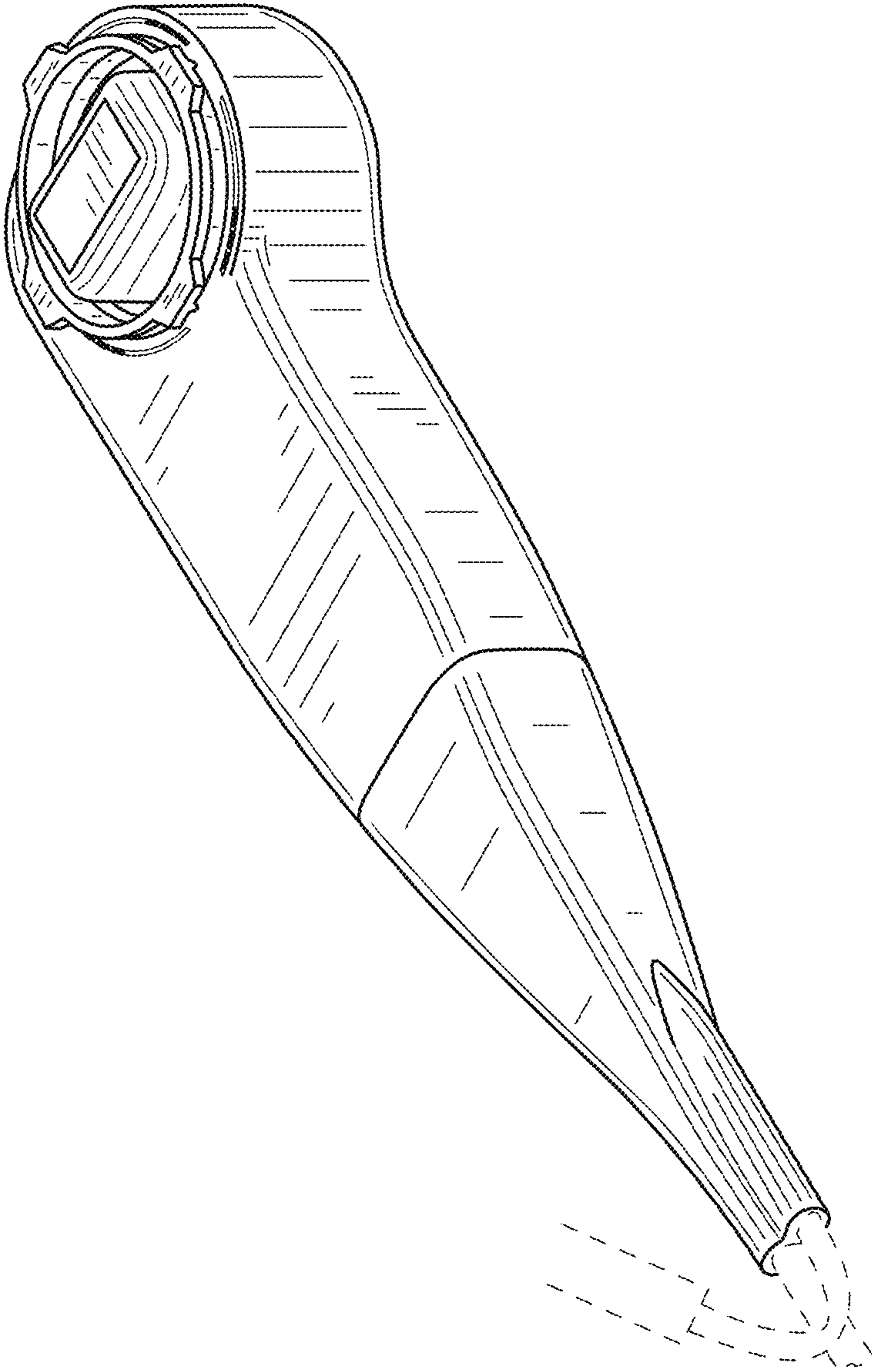

FIG.1

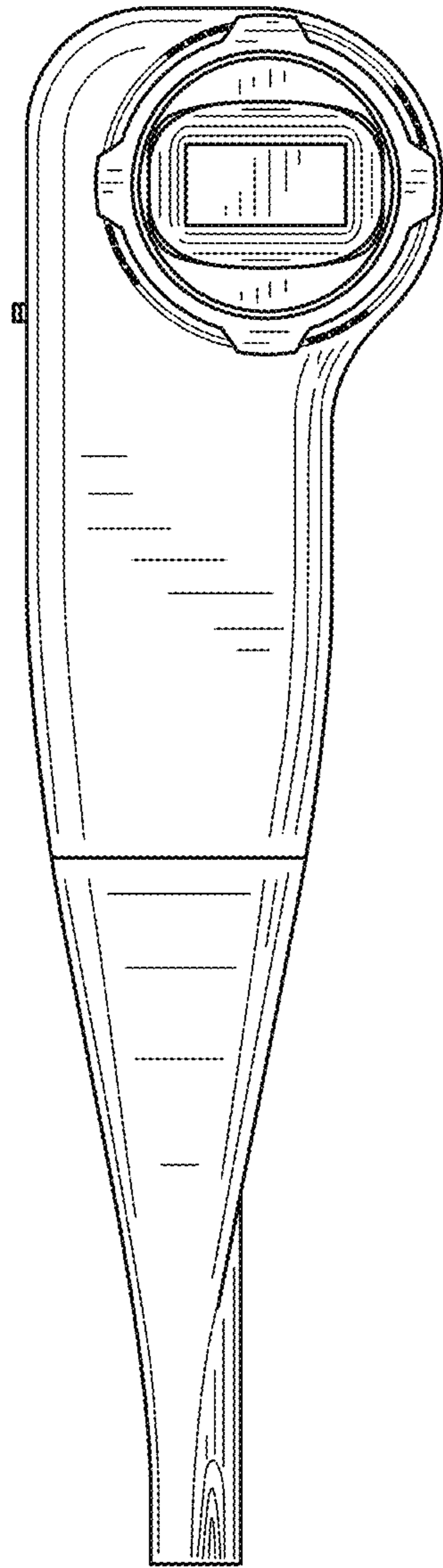

FIG.2

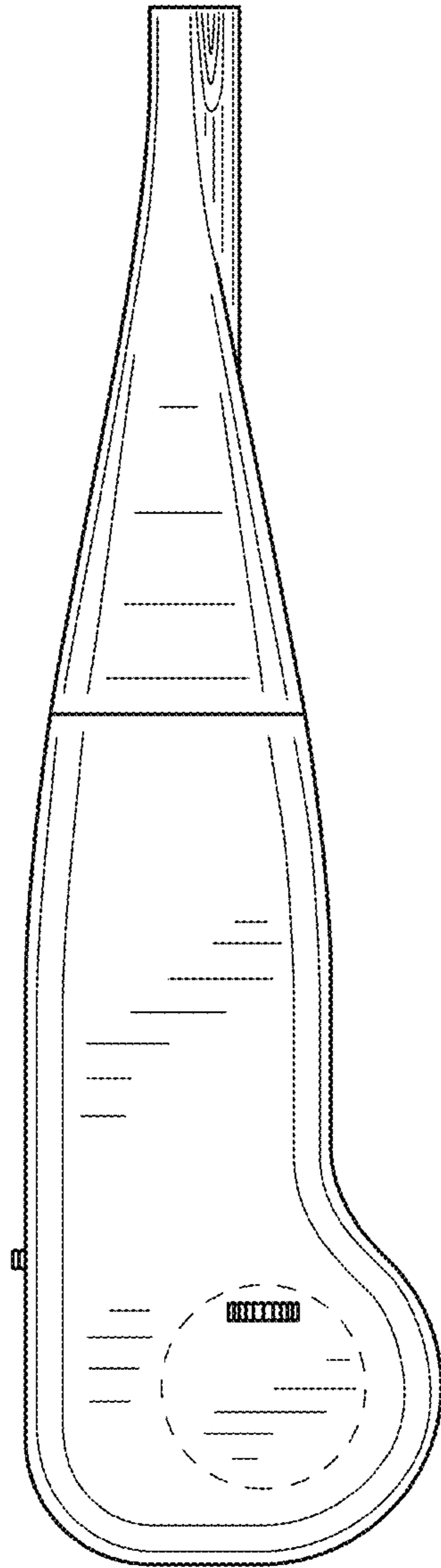

FIG.3

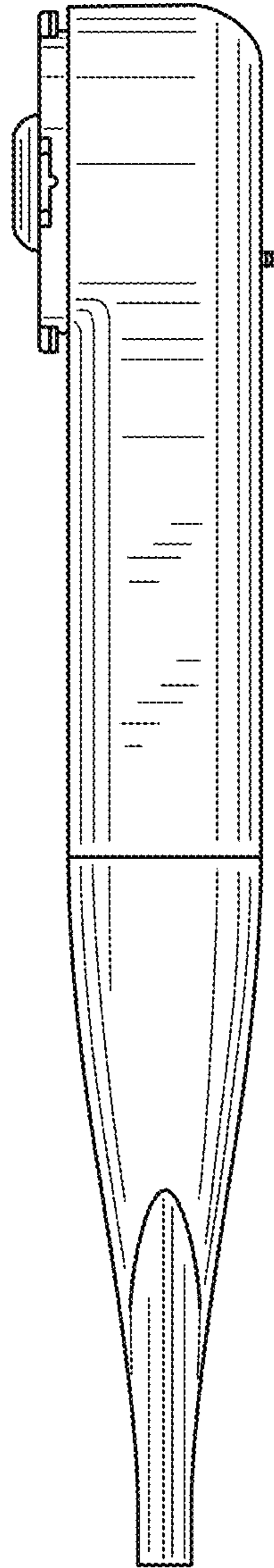

FIG.4

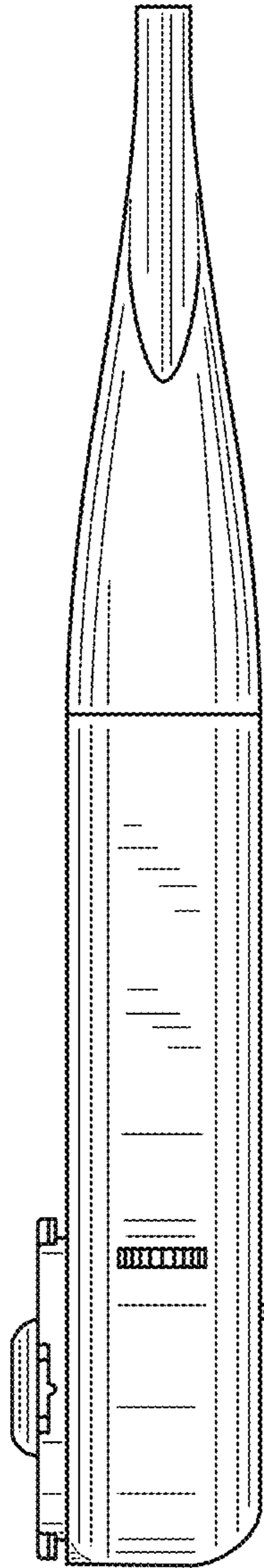

FIG. 5

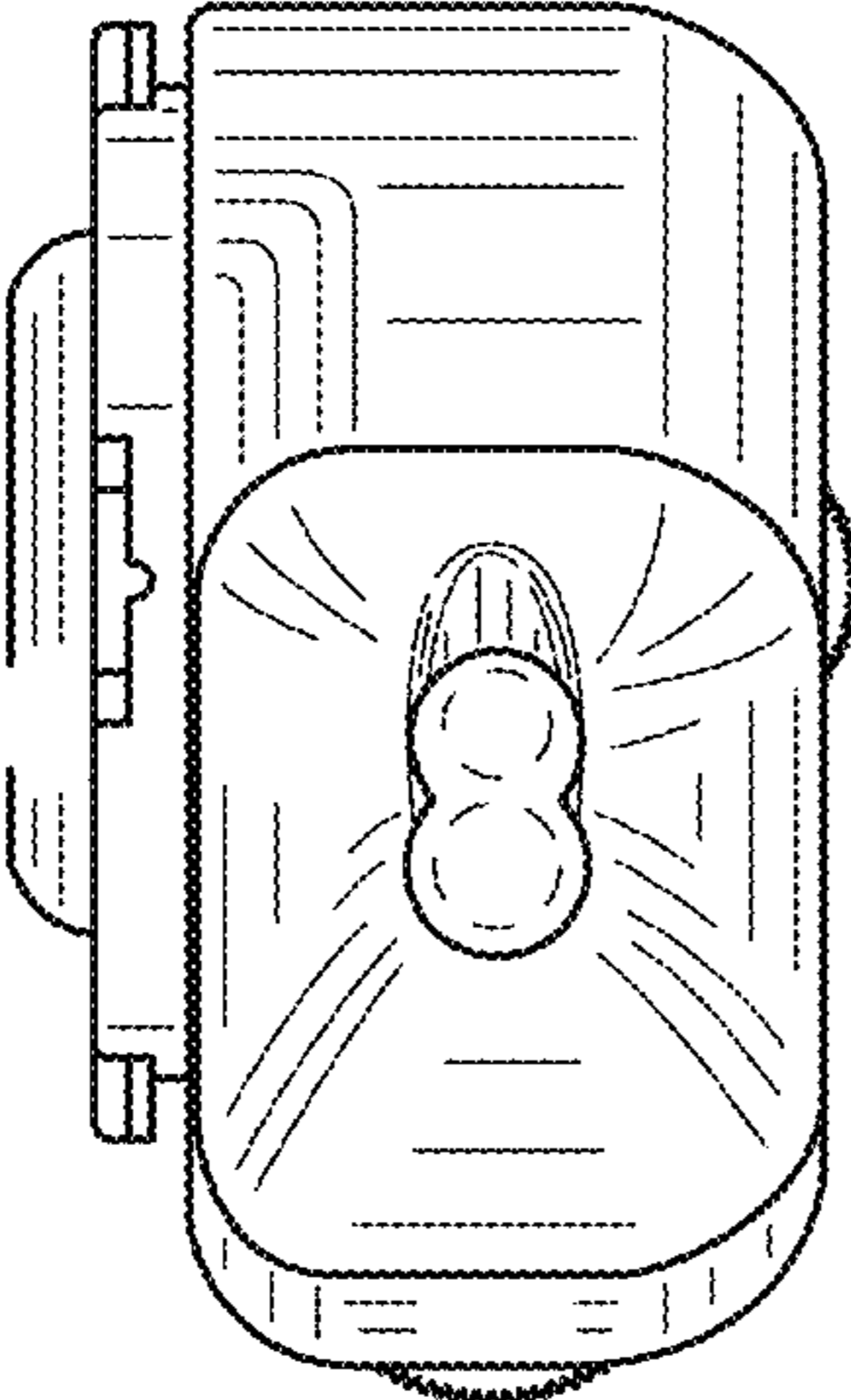

FIG.6

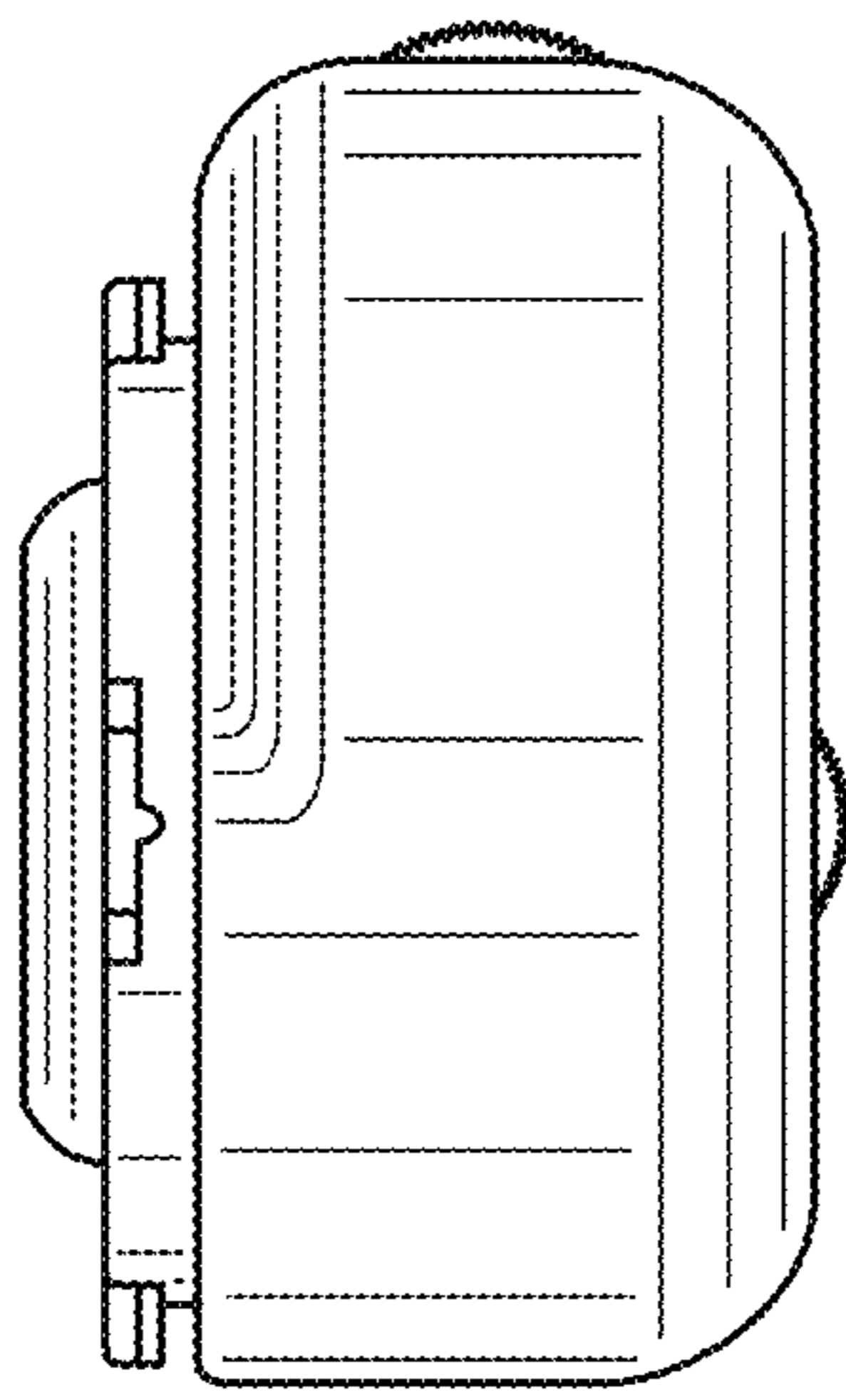

FIG.7