



US00D787297S

(12) **United States Design Patent** (10) **Patent No.:** **US D787,297 S**  
**Zimmer** (45) **Date of Patent:** **\*\* May 23, 2017**

(54) **CABINET KNOB** 5,499,427 A \* 3/1996 Bowman ..... A47B 95/02  
 16/417  
 (71) Applicant: **Hardware Resources, Inc.**, Bossier 6,062,616 A \* 5/2000 Smolarski ..... E05B 3/06  
 City, LA (US) 292/348  
 (72) Inventor: **Christine Zimmer**, Hillsborough, NJ D584,127 S \* 1/2009 Matijevic ..... D8/305  
 (US) D592,483 S \* 5/2009 Ricereto ..... D8/307  
 D679,982 S \* 4/2013 Ramsland ..... D8/307  
 D754,518 S \* 4/2016 Bahler ..... D8/310  
 D772,686 S \* 11/2016 Zimmer ..... D8/310  
 D772,688 S \* 11/2016 Zimmer ..... D8/310  
 (73) Assignee: **HARDWARE RESOURCES, INC.**, 2006/0174446 A1 \* 8/2006 Lautenschlager ..... A47B 95/02  
 Bossier City, LA (US) 16/417  
 (\*\*) Term: **15 Years** 2010/0139046 A1 \* 6/2010 Daniels ..... A47B 95/02  
 16/414

(21) Appl. No.: **29/568,920**

(22) Filed: **Jun. 22, 2016**

(51) **LOC (10) Cl.** ..... **08-06**

(52) **U.S. Cl.**  
USPC ..... **D8/310**

(58) **Field of Classification Search**  
 USPC ..... D8/300, 307, 310; D7/393; D23/250,  
 D23/252, 254  
 CPC ... Y10T 292/57; Y10T 16/469; Y10T 292/82;  
 Y10T 74/2084; Y10T 292/85; Y10T  
 16/458; Y10T 16/506; Y10T 70/5155;  
 Y10T 16/46; Y10T 16/4559; Y10T  
 74/20828; Y10T 70/8541; Y10T  
 74/20612; Y10T 16/459; Y10T 16/487;  
 Y10T 70/5389; Y10T 16/462; Y10T  
 16/4636; E05B 1/0007; E05B 3/00; Y10S  
 16/30; Y10S 292/53; Y10S 292/27  
 See application file for complete search history.

(56) **References Cited**

**U.S. PATENT DOCUMENTS**

D51,333 S \* 10/1917 Heizmann ..... D8/310  
 1,536,684 A \* 5/1925 Morgan ..... C22C 38/04  
 16/414

\* cited by examiner

*Primary Examiner* — Derrick Holland

*Assistant Examiner* — Lauren Calve

(74) *Attorney, Agent, or Firm* — Schultz & Associates,  
P.C.

(57) **CLAIM**

The ornamental design for a cabinet knob, as shown and described.

**DESCRIPTION**

FIG. 1 is a perspective view of a cabinet knob showing my new design;  
 FIG. 2 is a side elevation view thereof;  
 FIG. 3 is top plan view thereof; and,  
 FIG. 4 is a bottom plan view thereof.  
 The broken lines shown represent unclaimed subject matter and form no part of the claimed design.

**1 Claim, 2 Drawing Sheets**

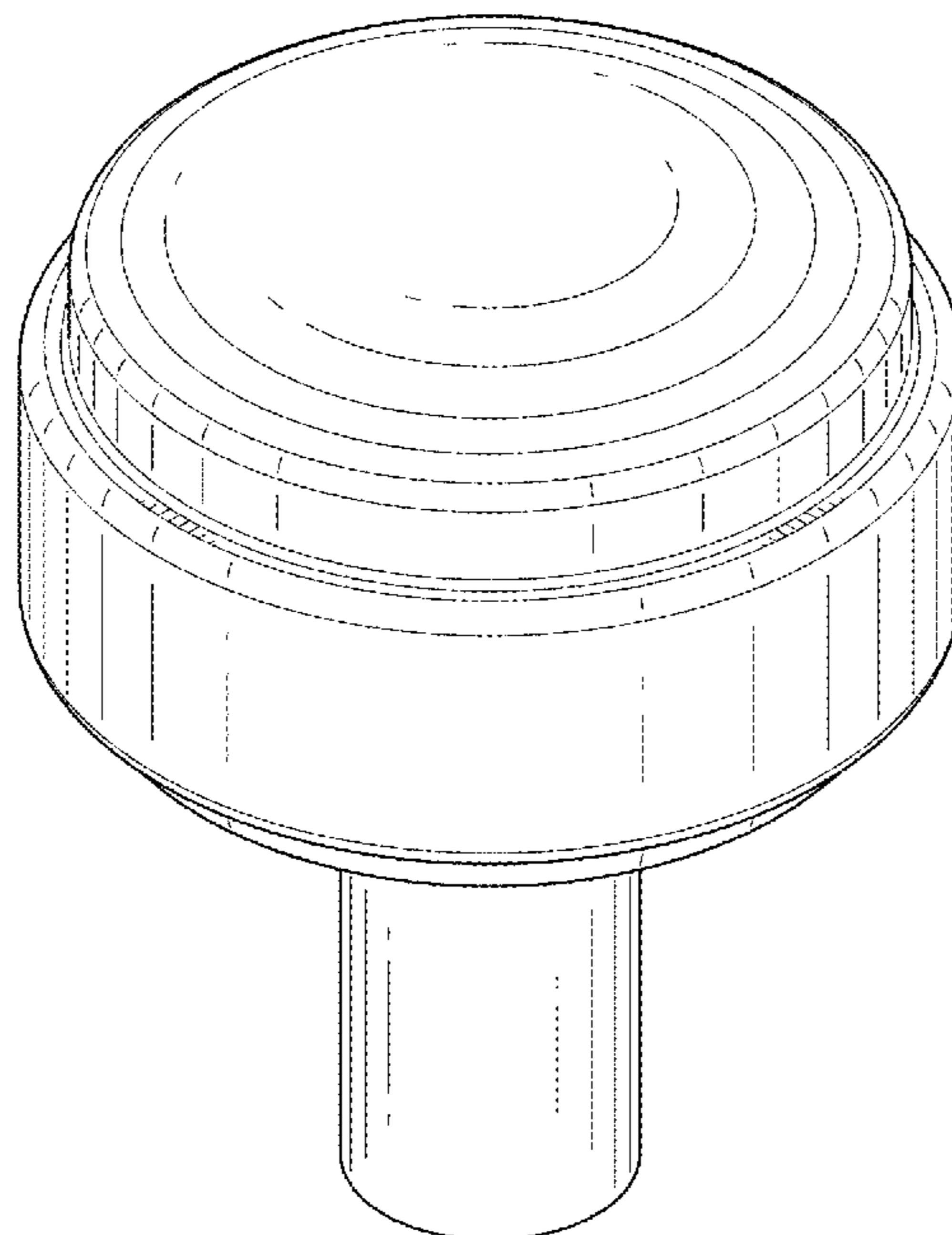

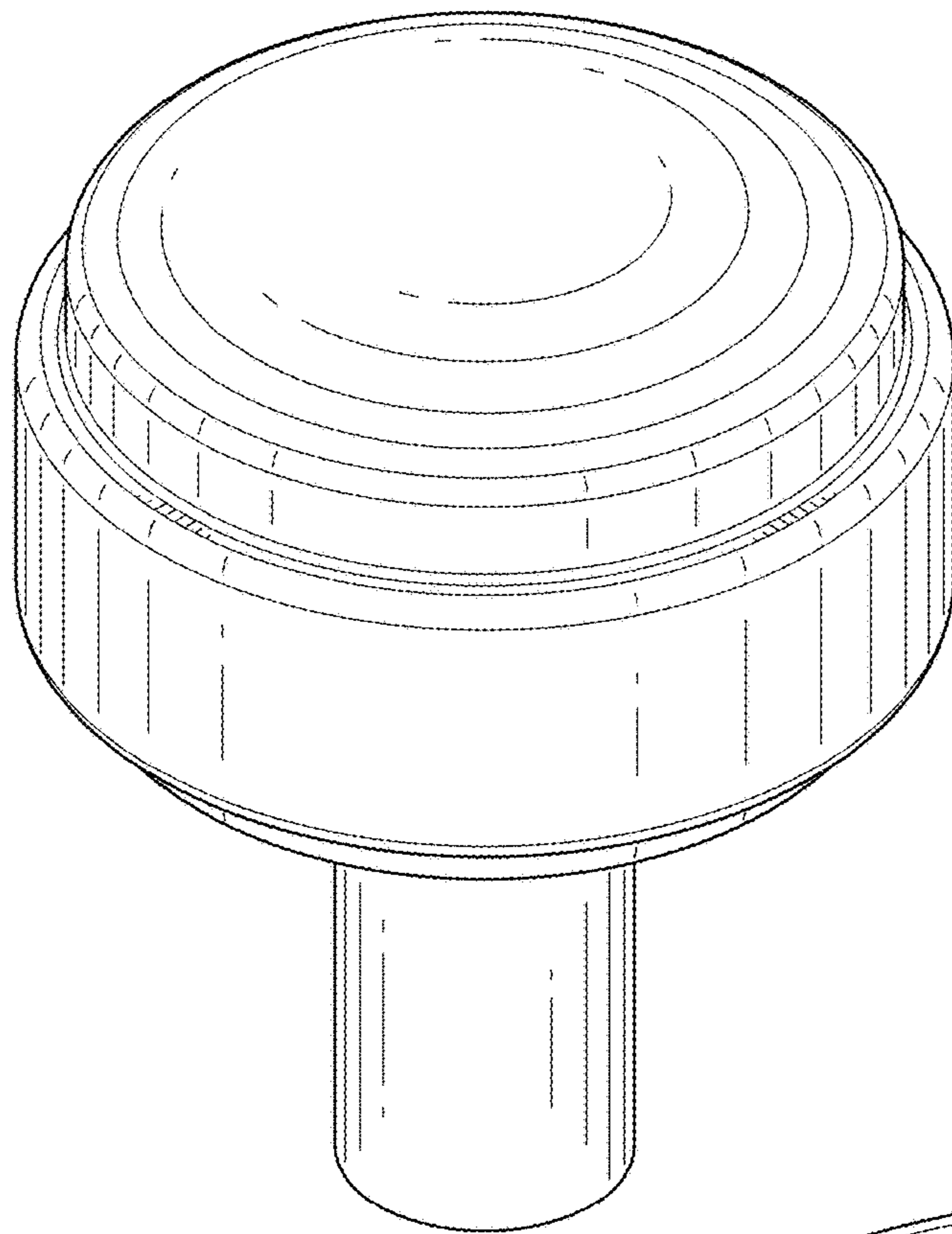

FIG. 1

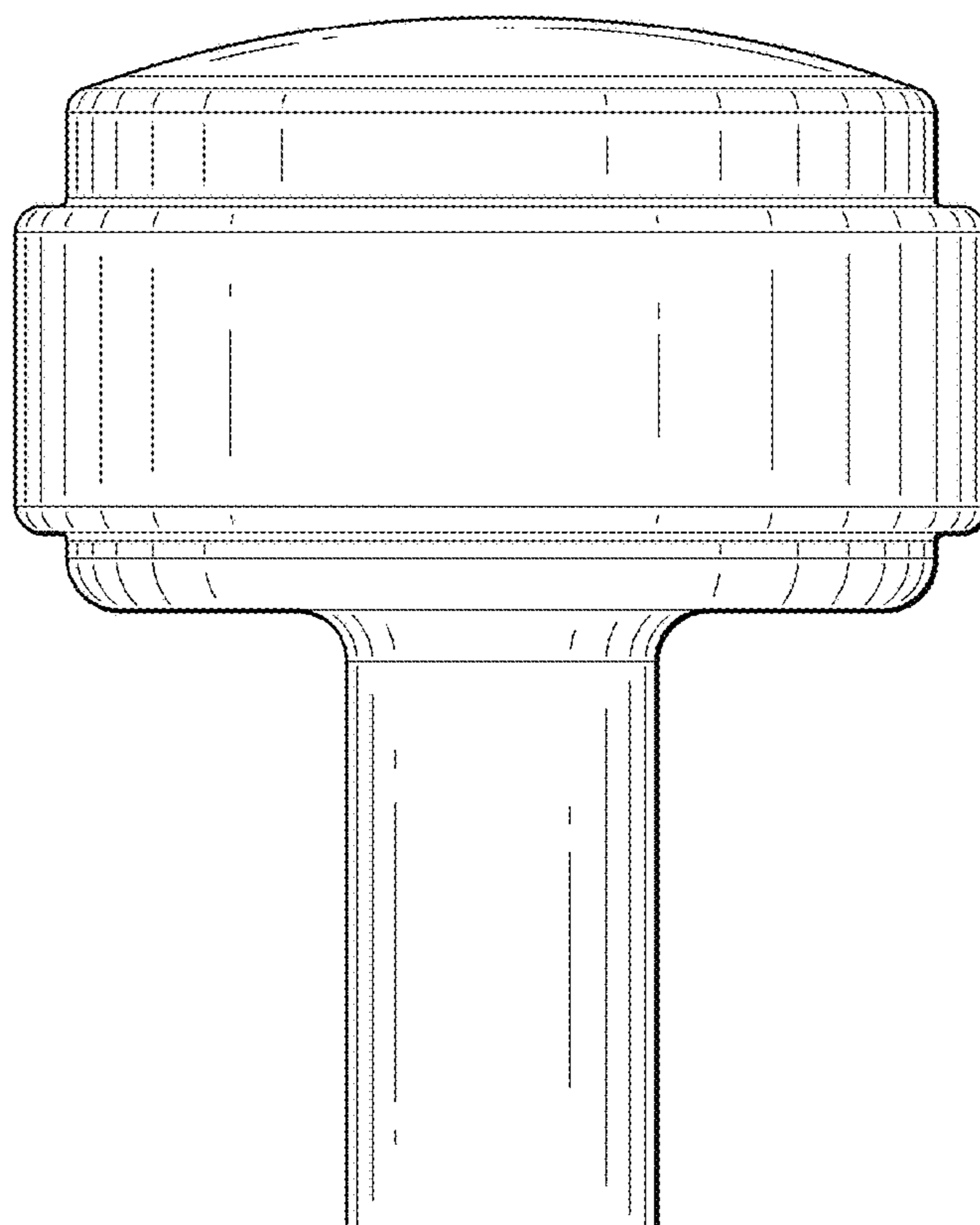

FIG. 2

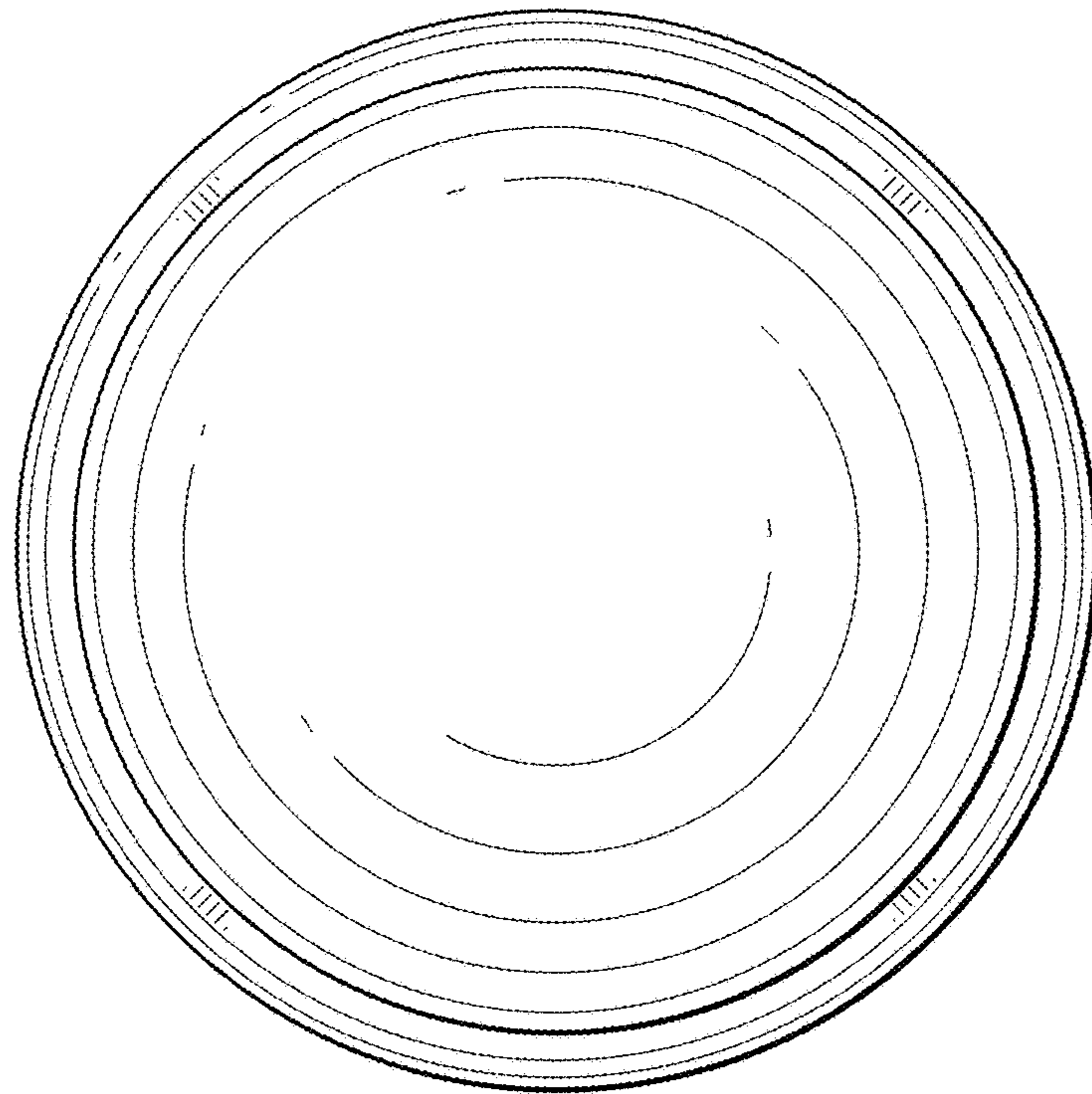

FIG. 3

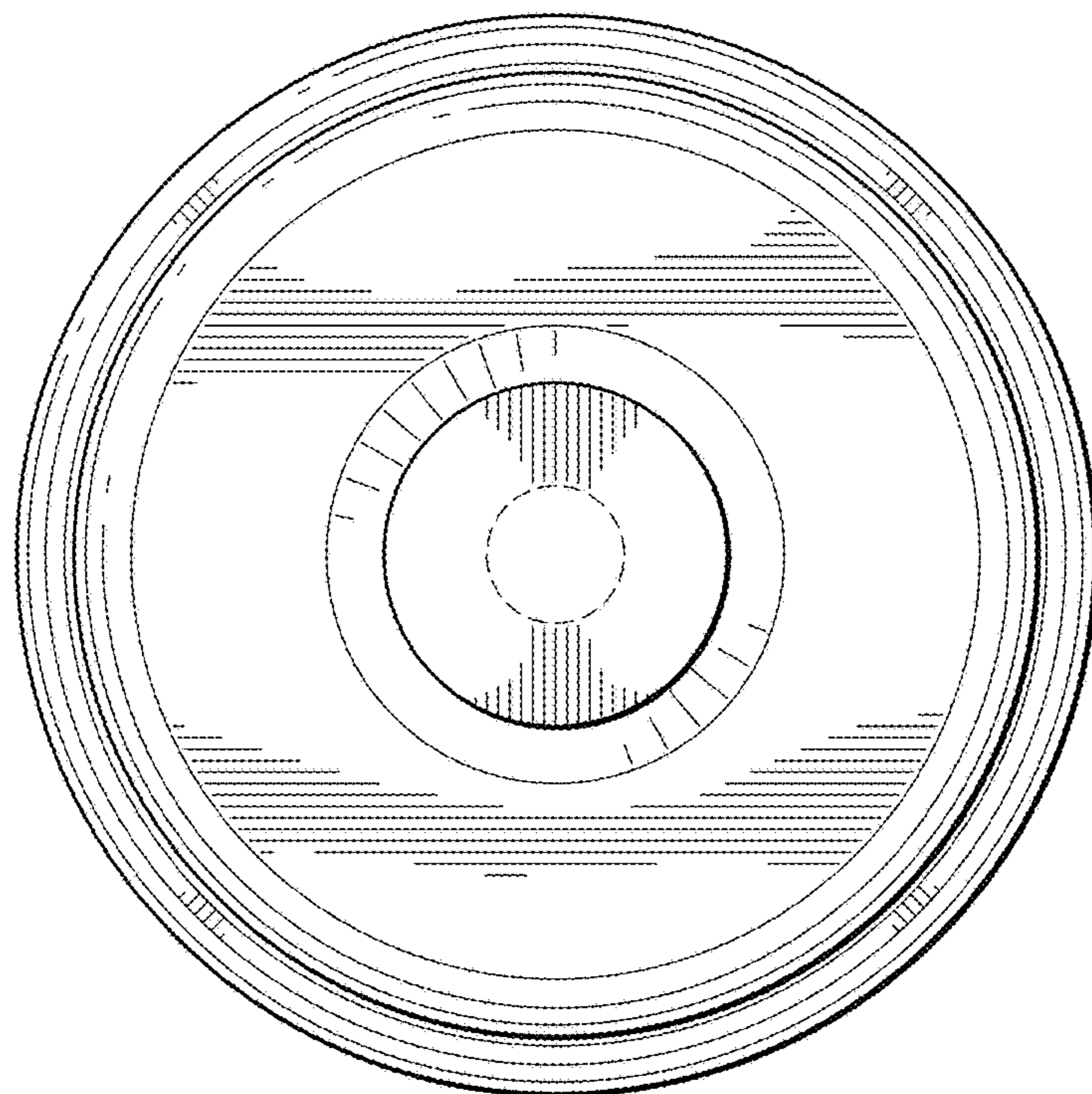

FIG. 4