



US00D787280S

(12) **United States Design Patent** (10) **Patent No.:** **US D787,280 S**
Moreau (45) **Date of Patent:** **** May 23, 2017**

(54) **GRINDER**

(71) Applicant: **Kitchen Grindz Inc.**, Las Vegas, NV (US)

(72) Inventor: **Todd Moreau**, Las Vegas, NV (US)

(73) Assignee: **Kitchen Grindz Inc.**, Las Vegas, NV (US)

(**) Term: **14 Years**

(21) Appl. No.: **29/500,273**

(22) Filed: **Aug. 22, 2014**

(51) **LOC (10) Cl.** **07-04**

(52) **U.S. Cl.**
USPC **D7/679**

(58) **Field of Classification Search**
USPC D7/679, 590-600, 372, 373, 374, 401.1;
D9/515, 549, 556, 559

(Continued)

(56) **References Cited**

U.S. PATENT DOCUMENTS

4,135,672 A * 1/1979 Schlessel A47J 42/04
241/169.1
5,465,871 A * 11/1995 Robbins, III B65D 47/0814
222/142.5

(Continued)

Primary Examiner — Terry Wallace

(74) *Attorney, Agent, or Firm* — Snell & Wilmer LLP

(57) **CLAIM**

The ornamental design for the grinder, as shown and described.

DESCRIPTION

The patent or application file contains at least one drawing executed in color. Copies of this patent or patent application

publication with color drawing(s) will be provided by the Office upon request and payment of the necessary fee.

FIG. 1 is a perspective view of a grinder in accordance with an exemplary embodiment of the design;

FIG. 2 is a side view thereof;

FIG. 3 is a top view thereof; and

FIG. 4 is a bottom view thereof.

FIG. 5 is a perspective view of a grinder in accordance with another exemplary embodiment of the design;

FIG. 6 is a side view thereof;

FIG. 7 is a top view thereof; and

FIG. 8 is a bottom view thereof.

FIG. 9 is a perspective view of a grinder in accordance with another exemplary embodiment of the design;

FIG. 10 is a side view thereof;

FIG. 11 is a top view thereof; and

FIG. 12 is a bottom view thereof.

FIG. 13 is a perspective view of a grinder in accordance with another exemplary embodiment of the design;

FIG. 14 is a side view thereof;

FIG. 15 is a top view thereof; and

FIG. 16 is a bottom view thereof.

FIG. 17 is a perspective view of a grinder in accordance with another exemplary embodiment of the design;

FIG. 18 is a side view thereof;

FIG. 19 is a top view thereof; and

FIG. 20 is a bottom view thereof.

FIG. 21 is a perspective view of a grinder in accordance with another exemplary embodiment of the design;

FIG. 22 is a side view thereof;

FIG. 23 is a top view thereof; and

FIG. 24 is a bottom view thereof.

FIG. 25 is a perspective view of a grinder in accordance with another exemplary embodiment of the design;

FIG. 26 is a side view thereof;

FIG. 27 is a top view thereof; and

FIG. 28 is a bottom view thereof.

FIG. 29 is a perspective view of a grinder in accordance with another exemplary embodiment of the design;

FIG. 30 is a side view thereof;

FIG. 31 is a top view thereof; and,

FIG. 32 is a bottom view thereof.

1 Claim, 16 Drawing Sheets
(10 of 16 Drawing Sheet(s) Filed in Color)

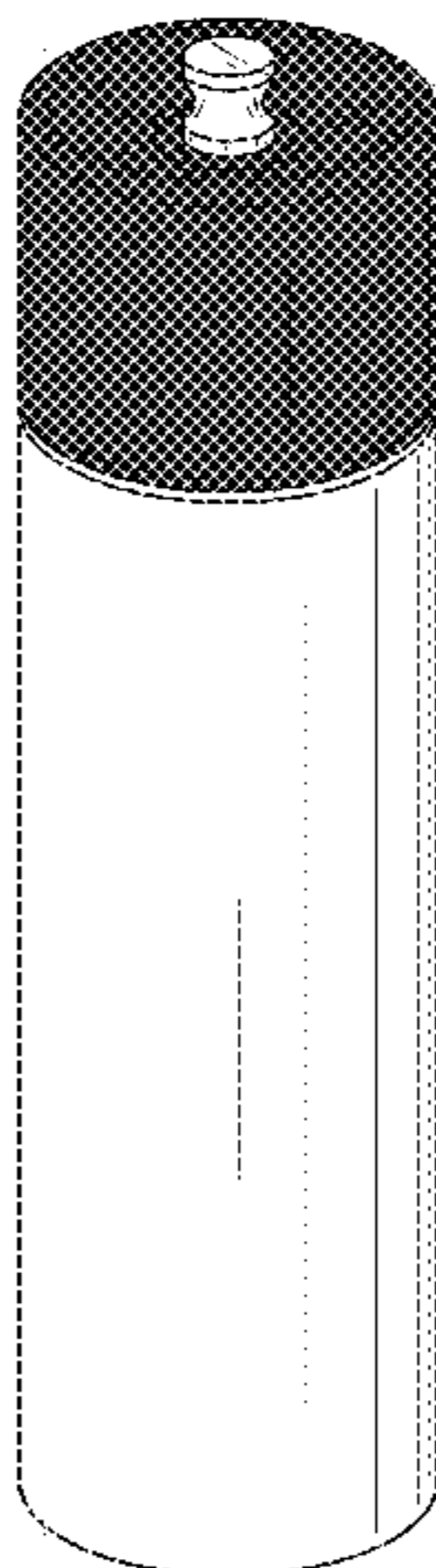

(58) **Field of Classification Search**

CPC .. A47J 42/04; A47J 43/40; A47J 42/14; A47J
42/34; A47J 43/04; B65D 47/0814

See application file for complete search history.

(56) **References Cited**

U.S. PATENT DOCUMENTS

D506,361 S *	6/2005	Lee	D7/679
D530,993 S *	10/2006	Kolflat	D7/679
D671,787 S *	12/2012	Lin	D7/300.1
2005/0274835 A1 *	12/2005	Huang	A47J 42/04 241/169.1
2009/0095832 A1 *	4/2009	Wu	A47J 42/40 241/169.1

* cited by examiner

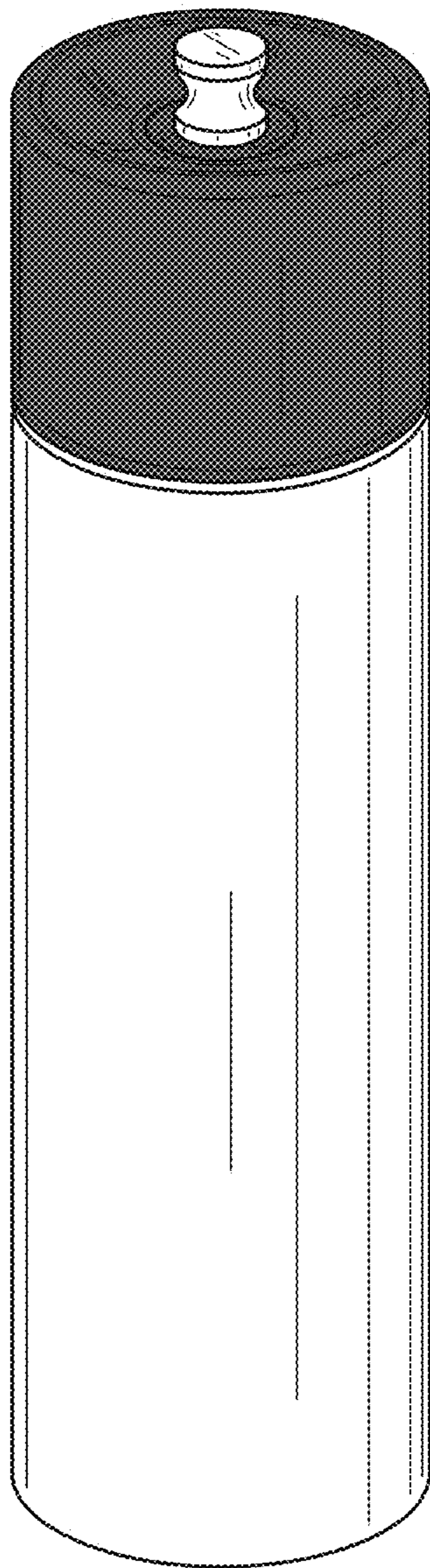

FIG. 1

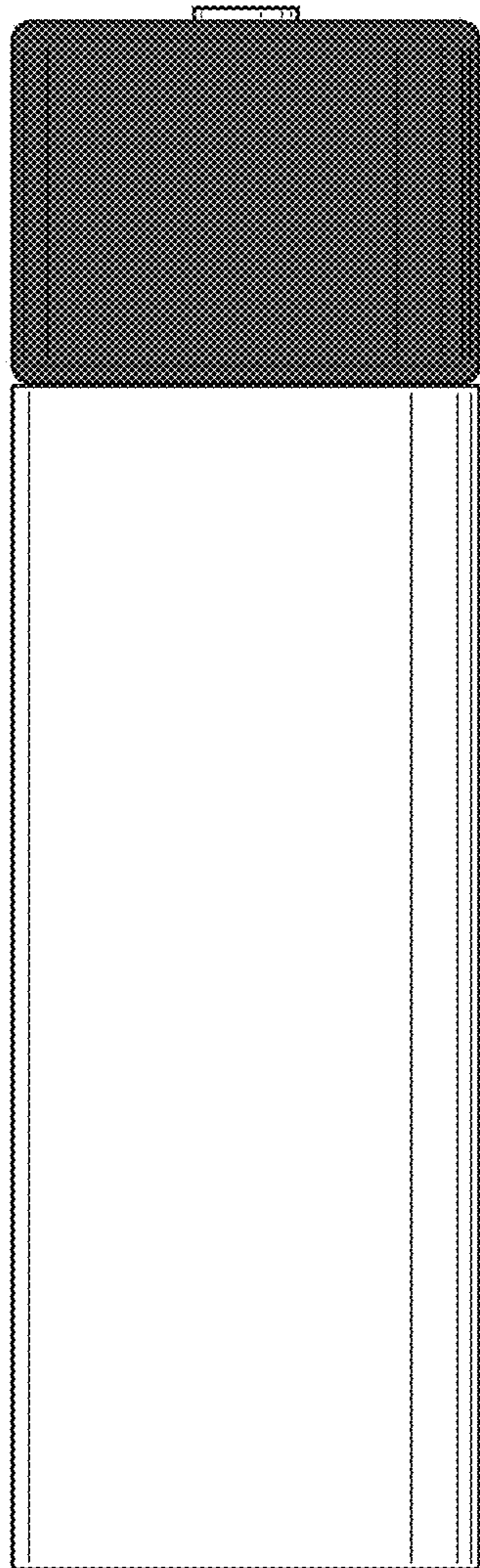

FIG. 2

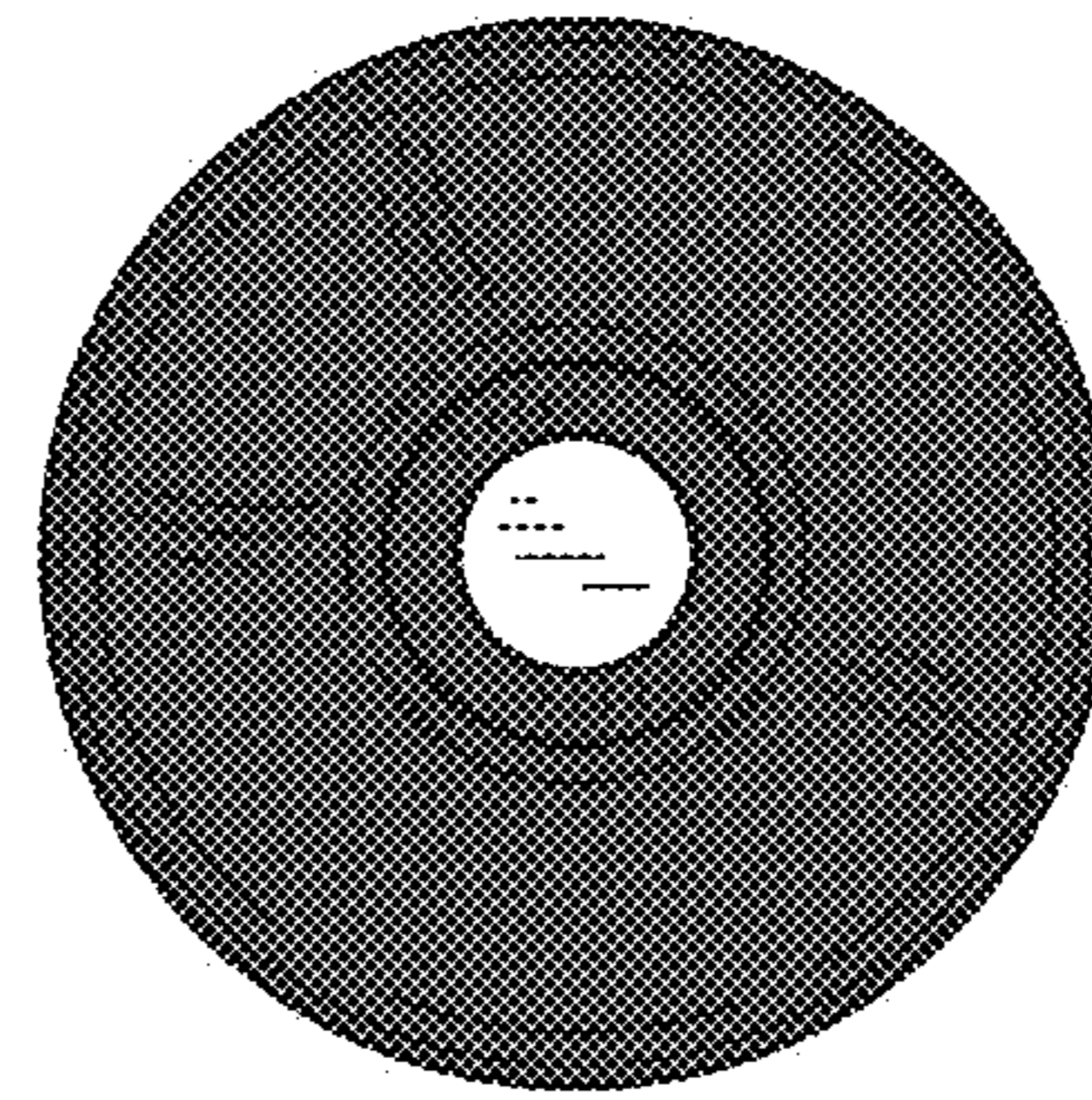

FIG. 3

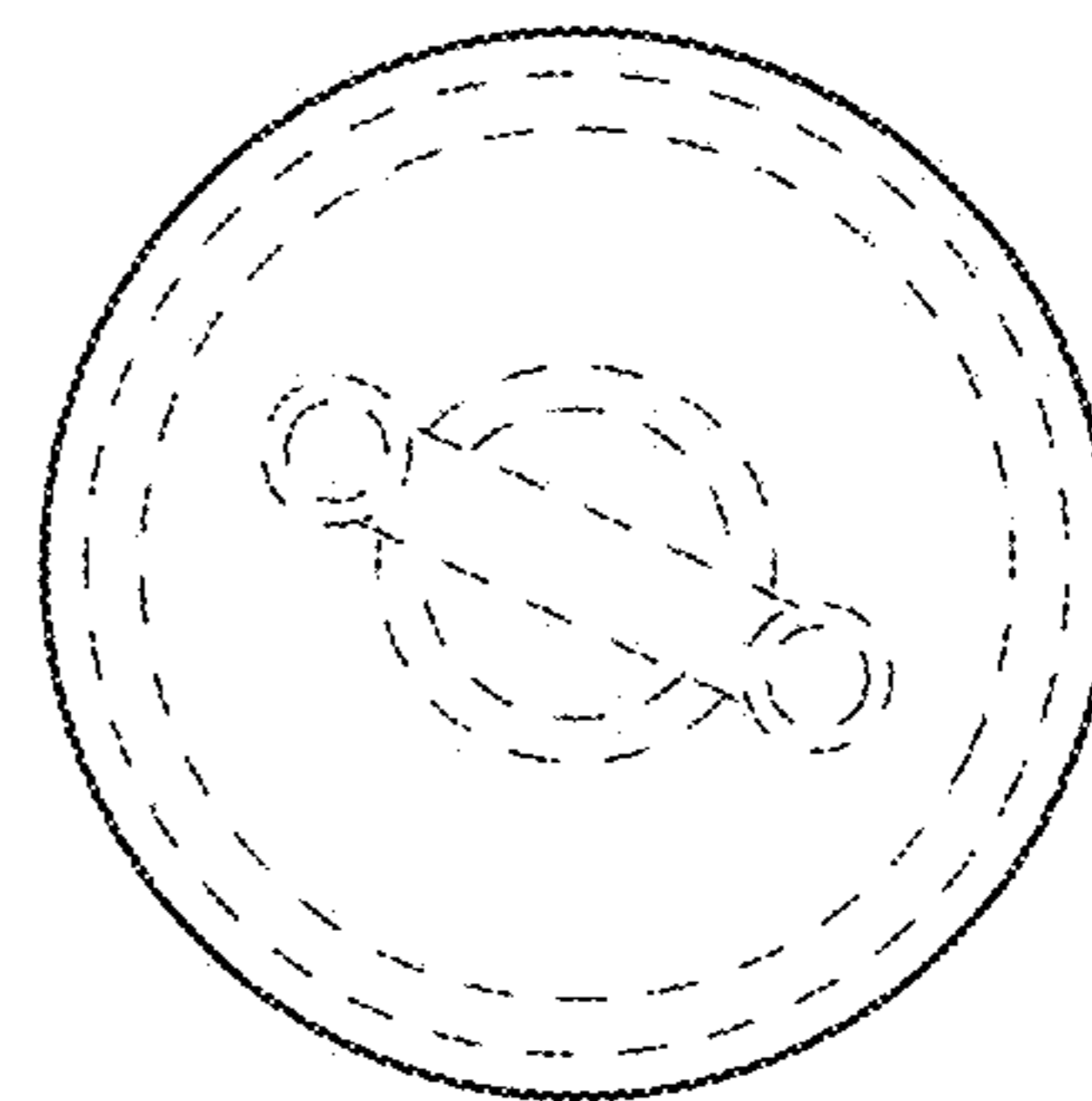

FIG. 4

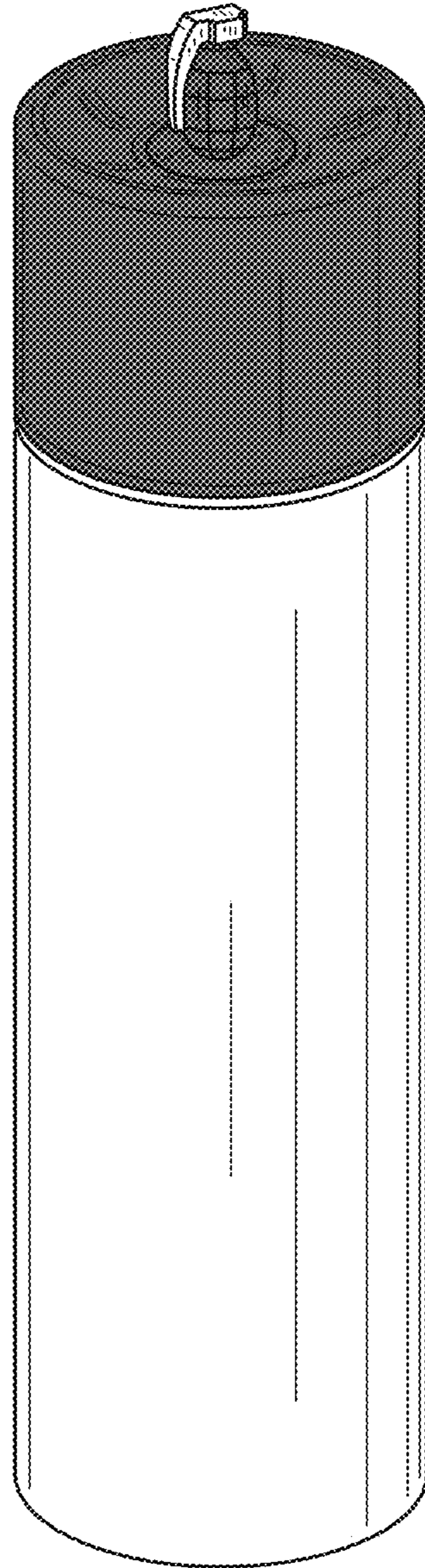

FIG.5

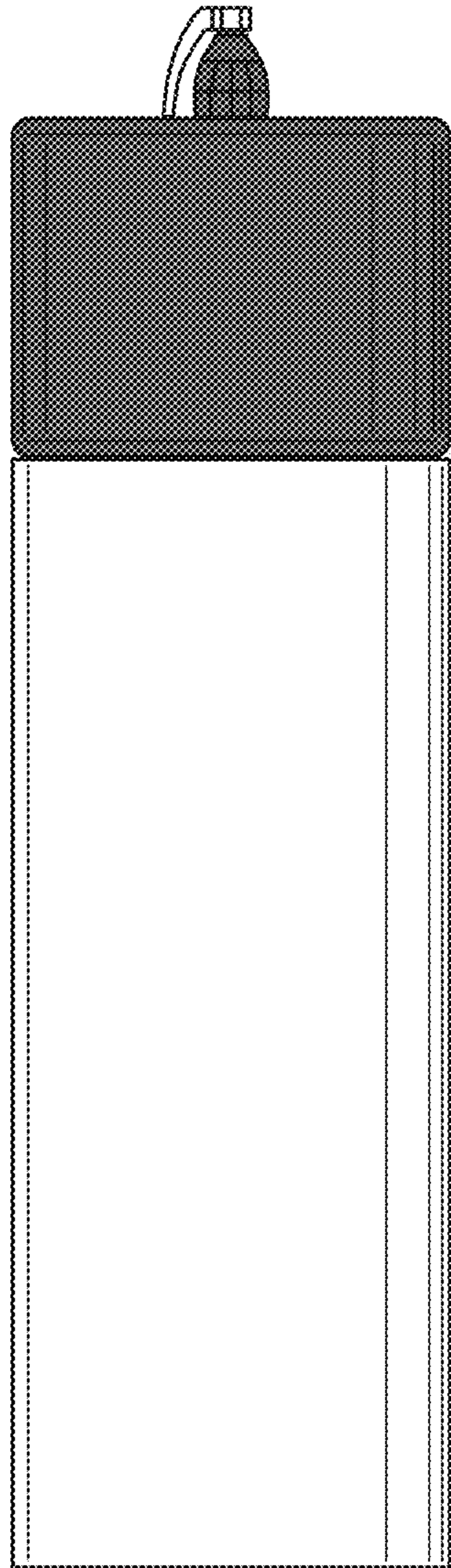

FIG. 6

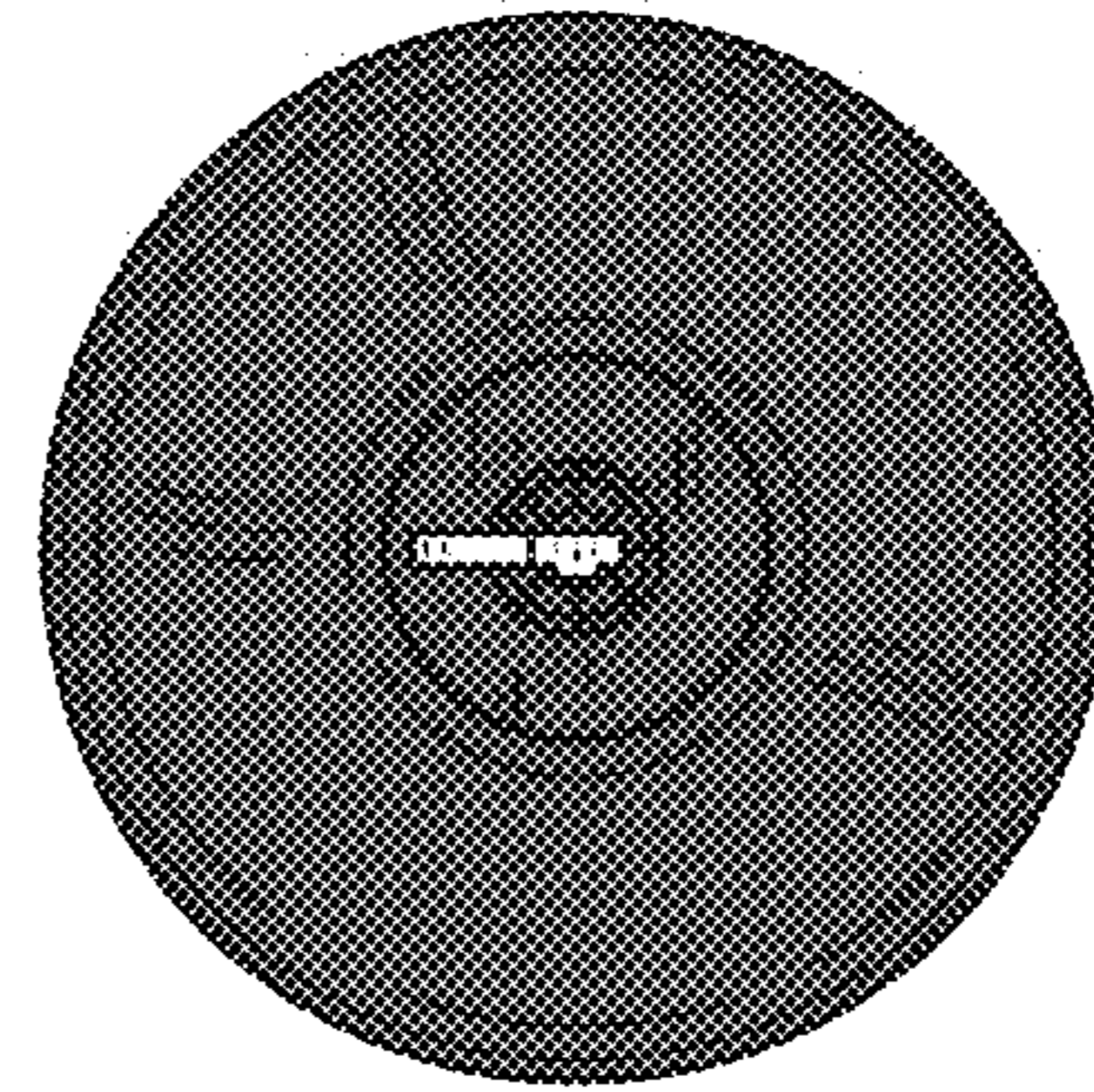

FIG. 7

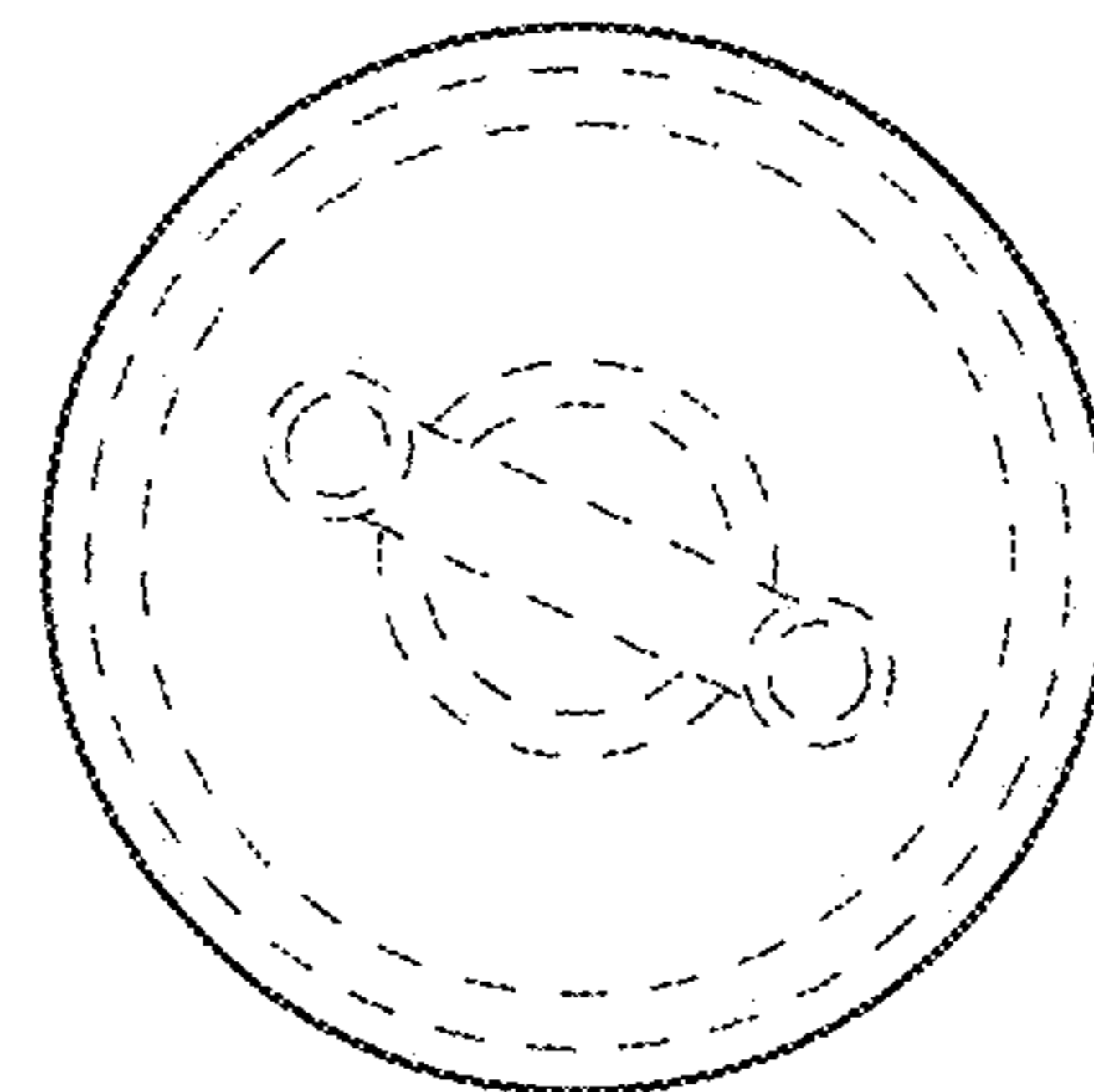

FIG. 8

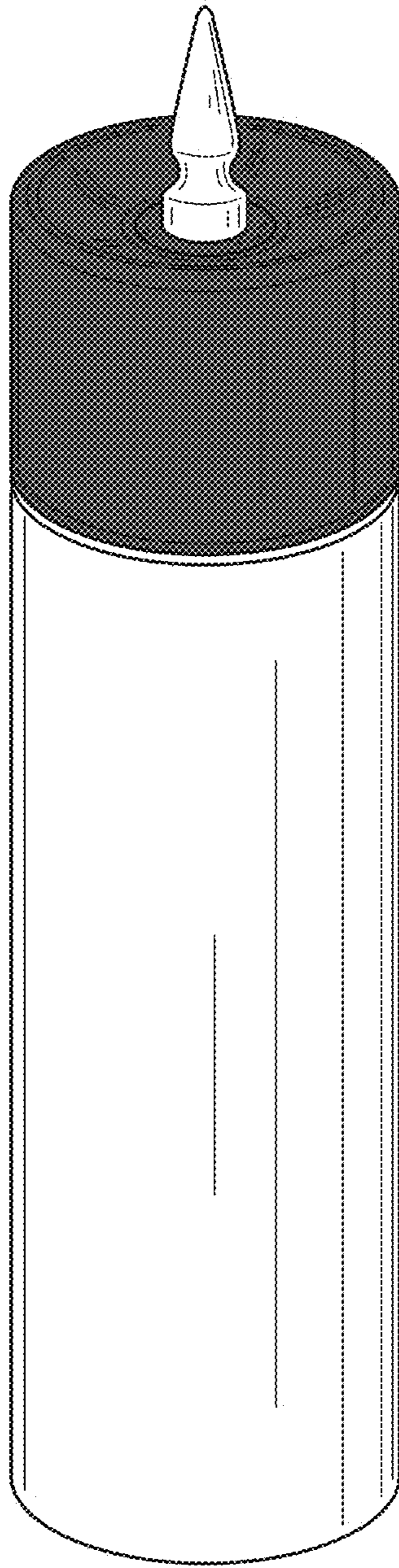

FIG.9

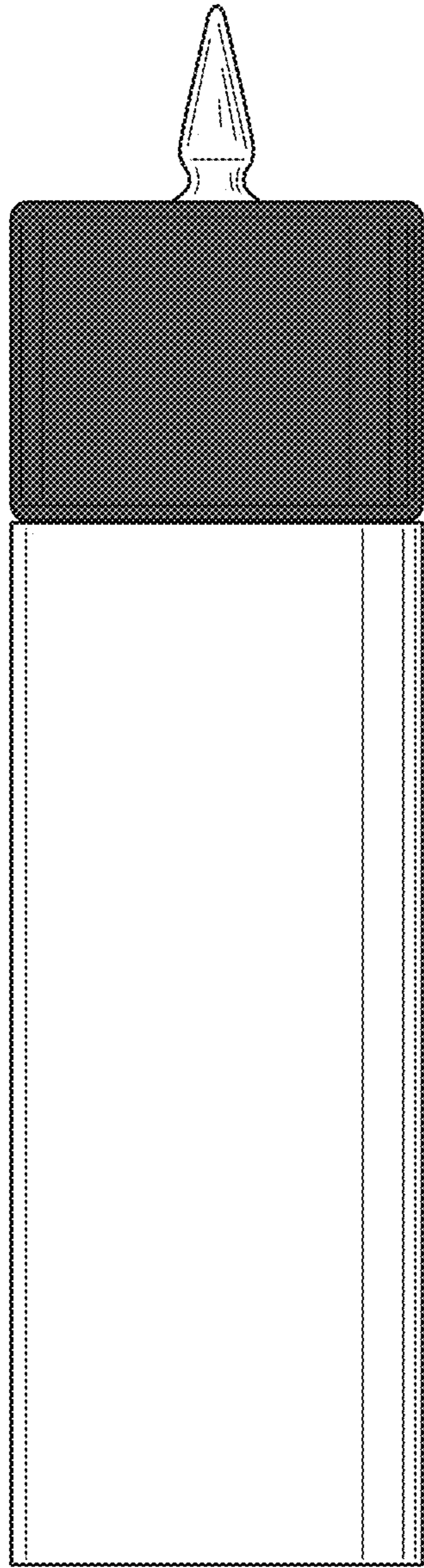

FIG. 10

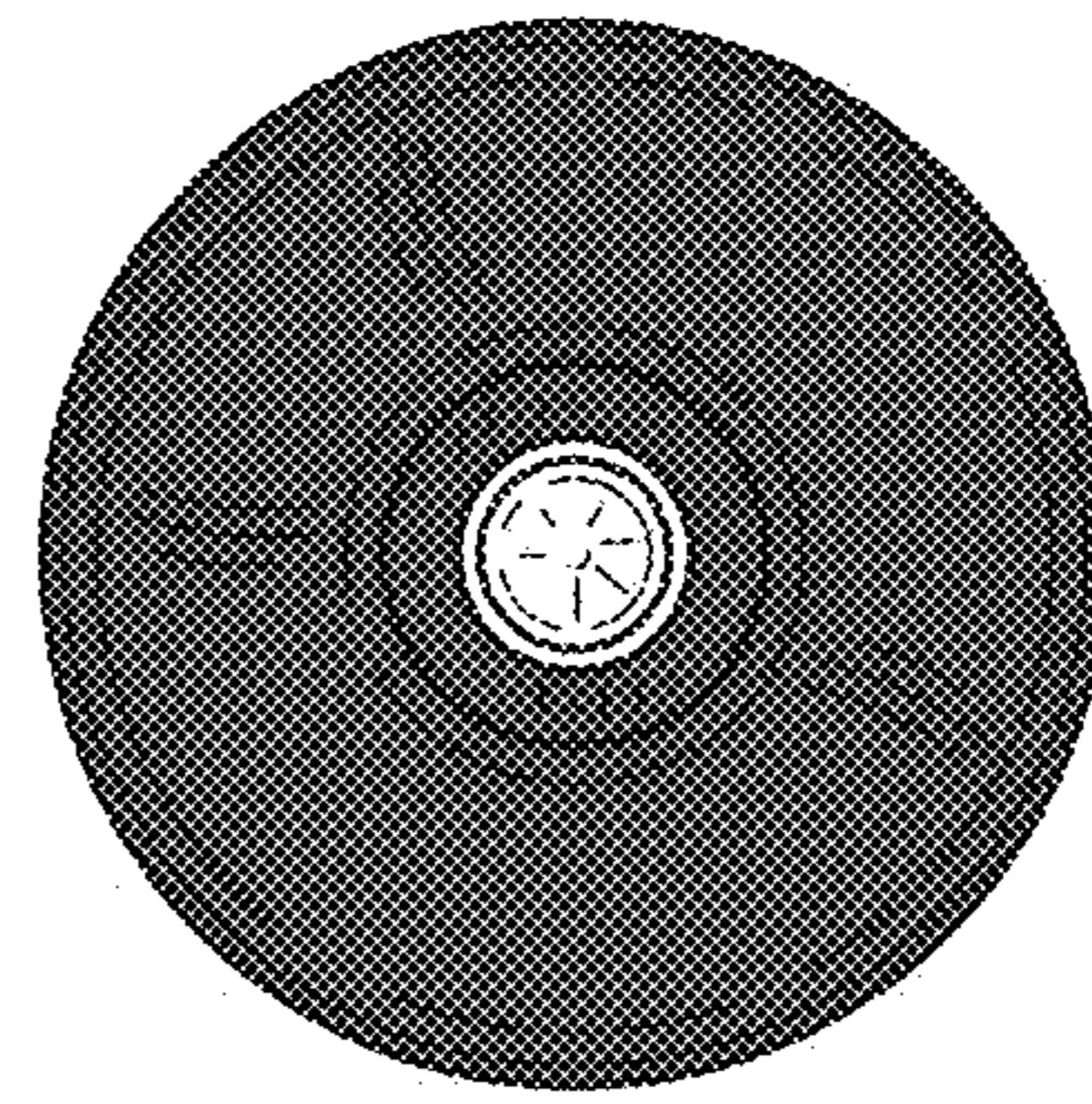

FIG. 11

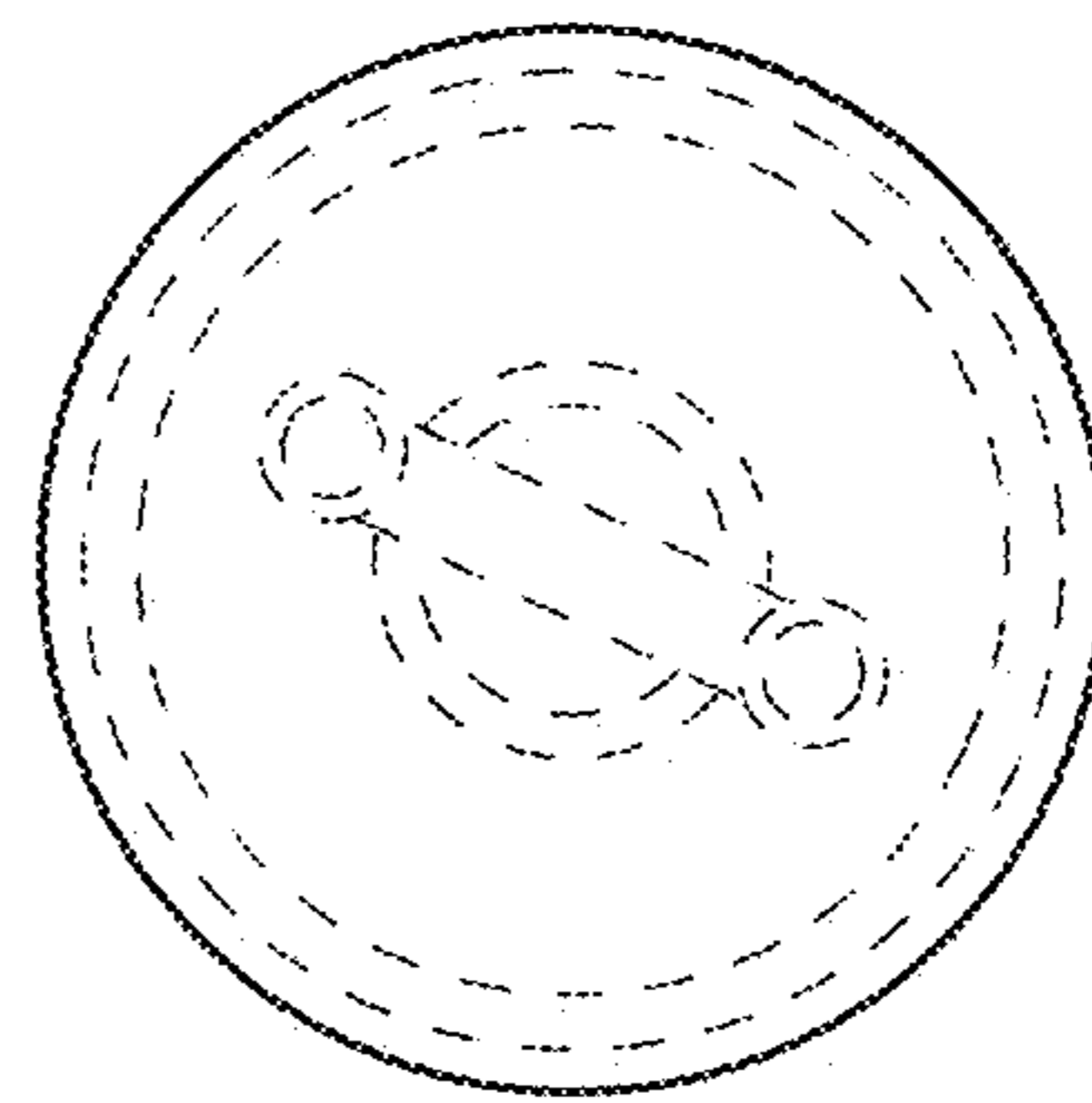

FIG. 12

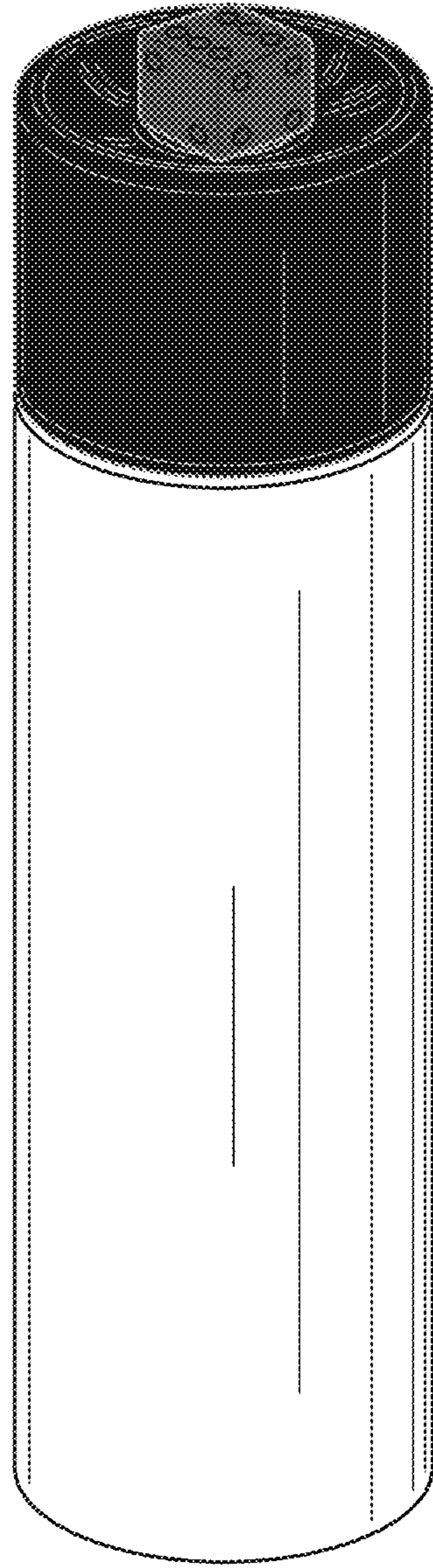

FIG. 13

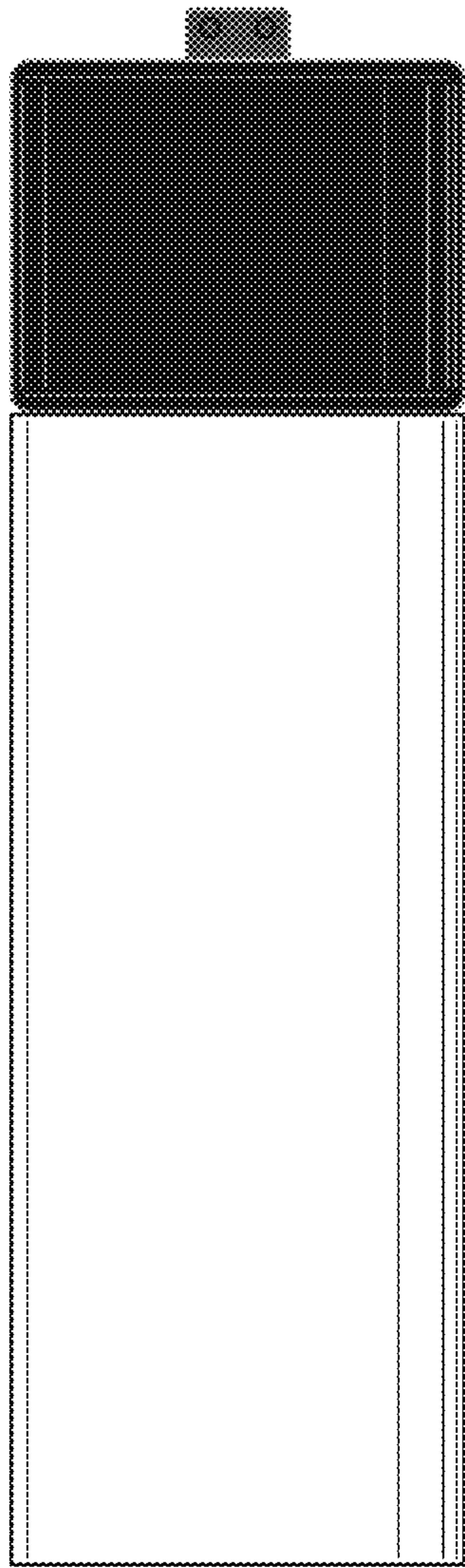

FIG. 14

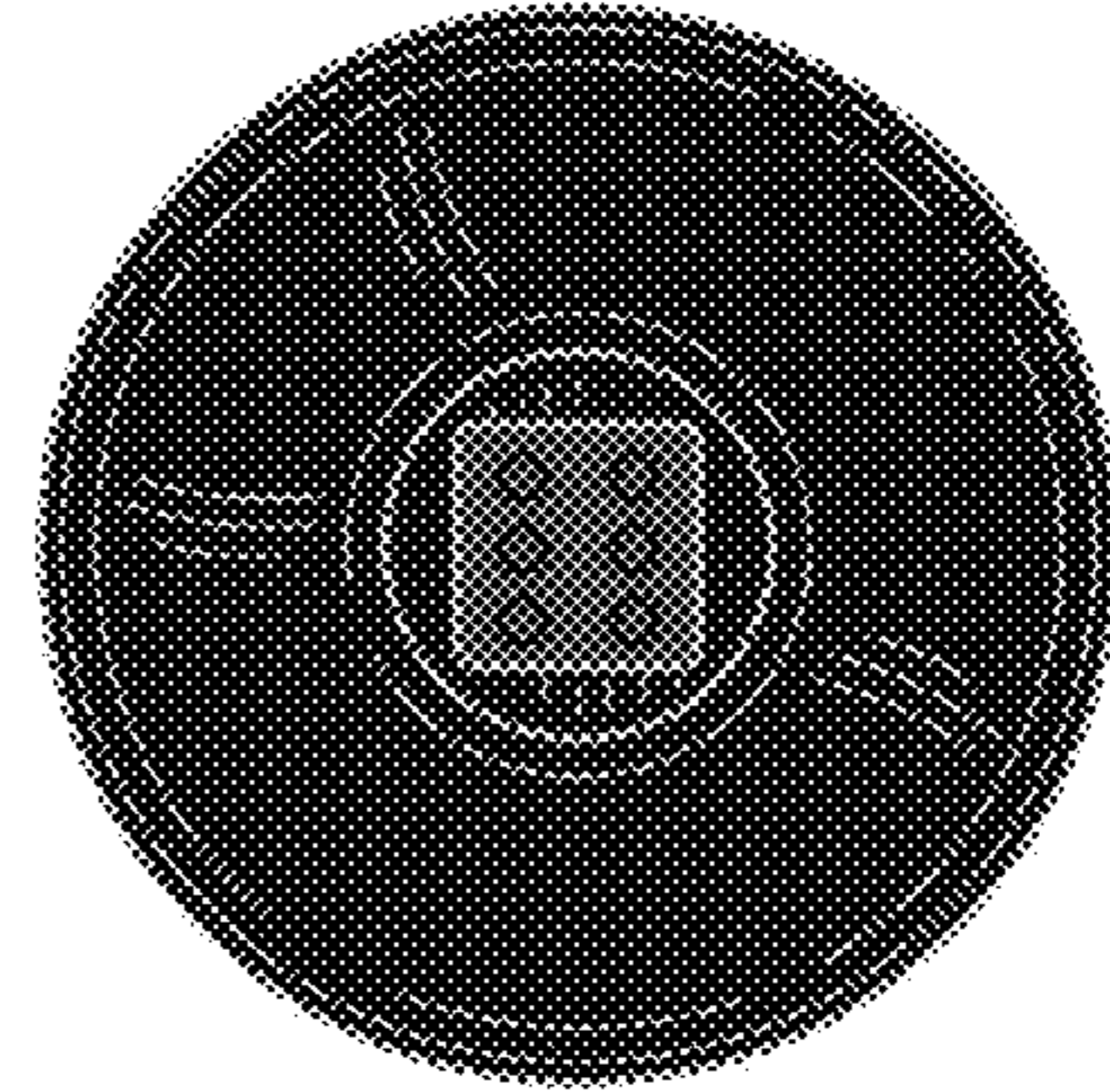

FIG. 15

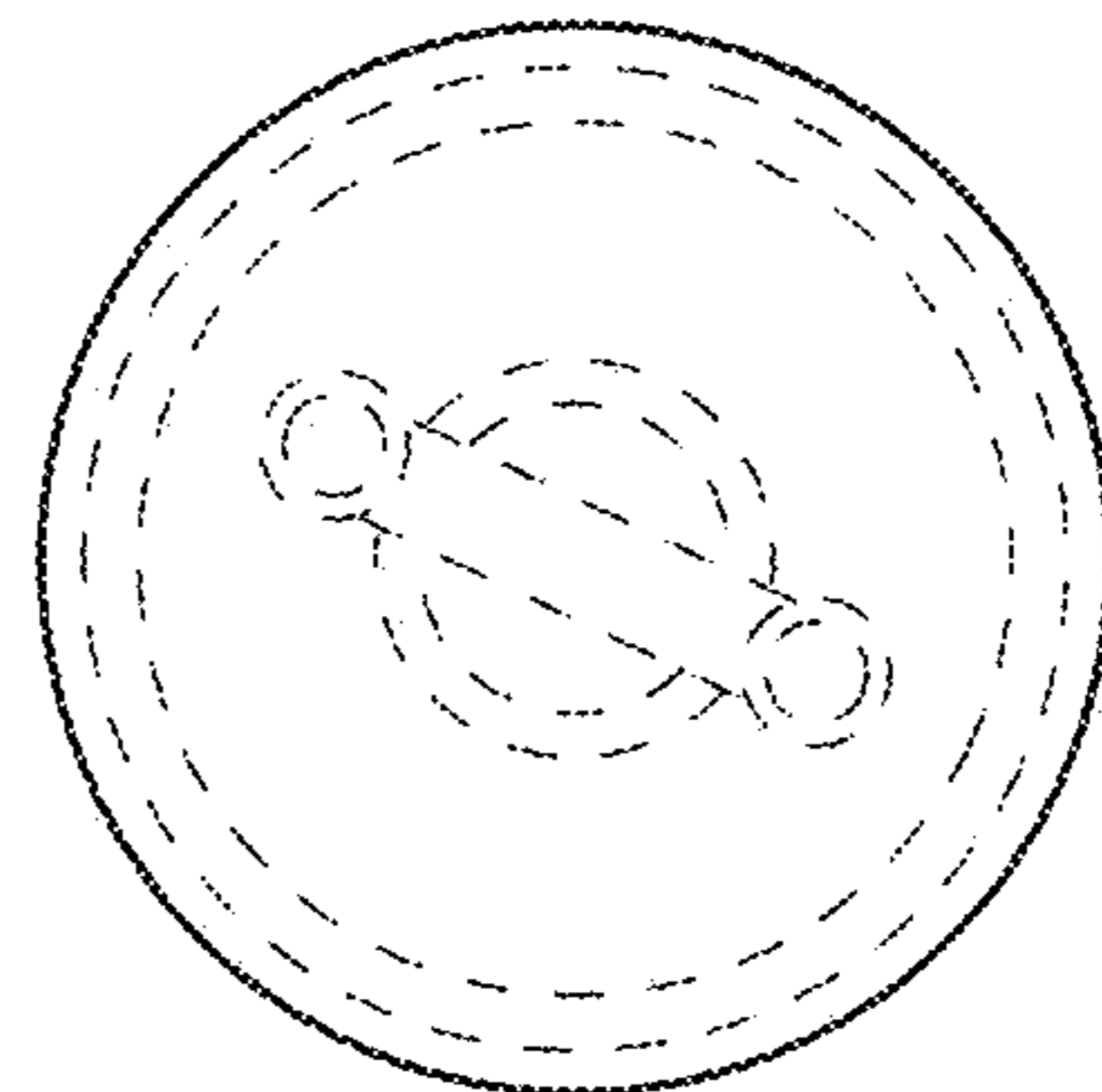

FIG. 16

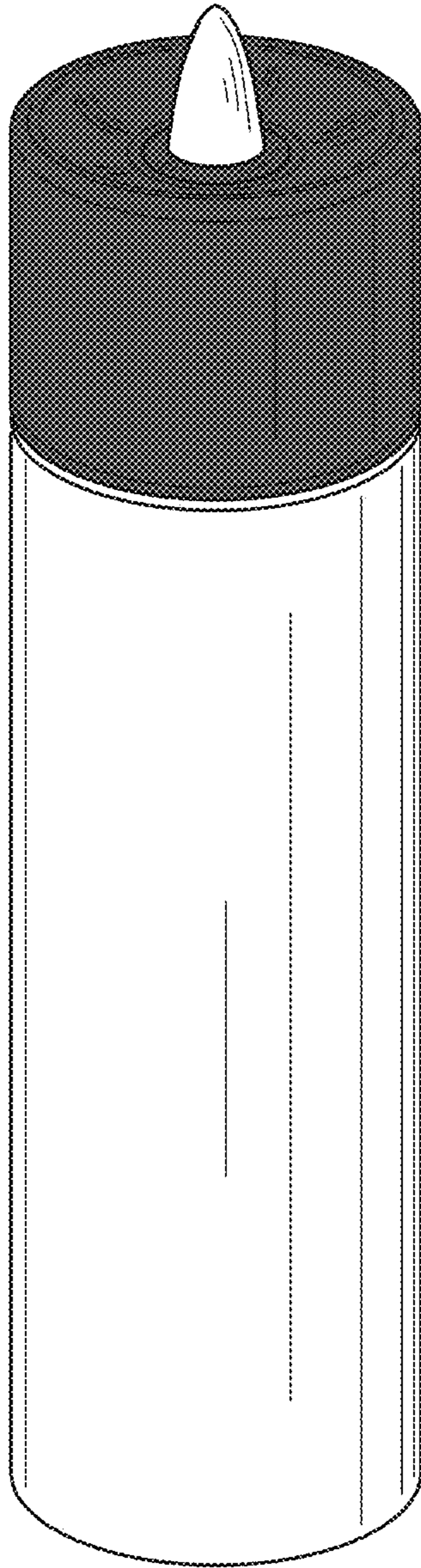

FIG.17

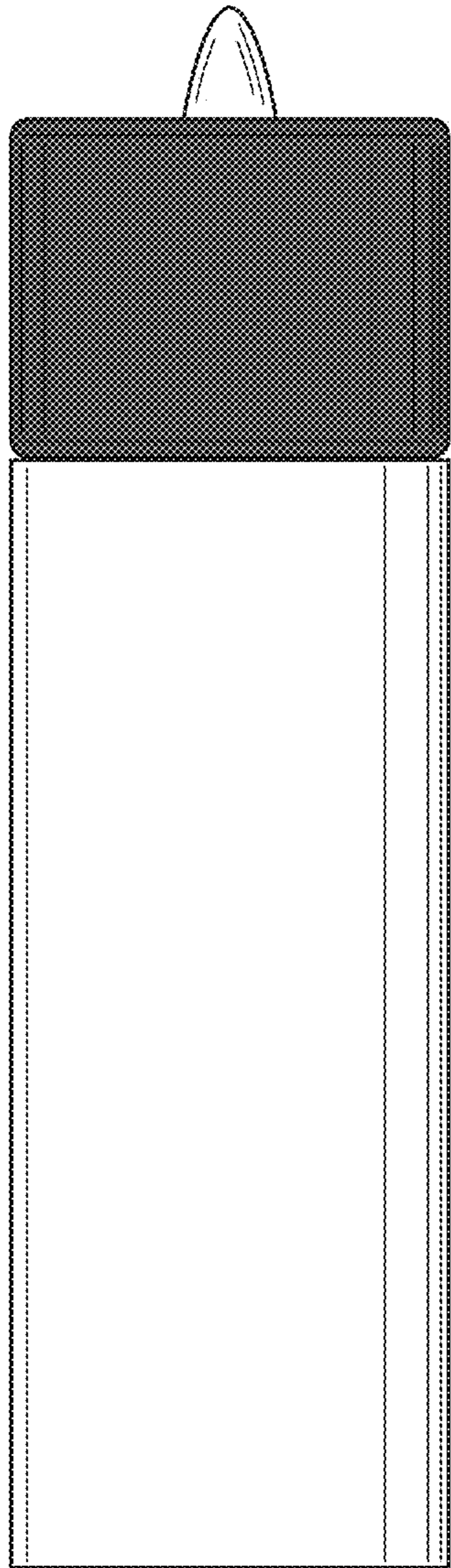

FIG. 18

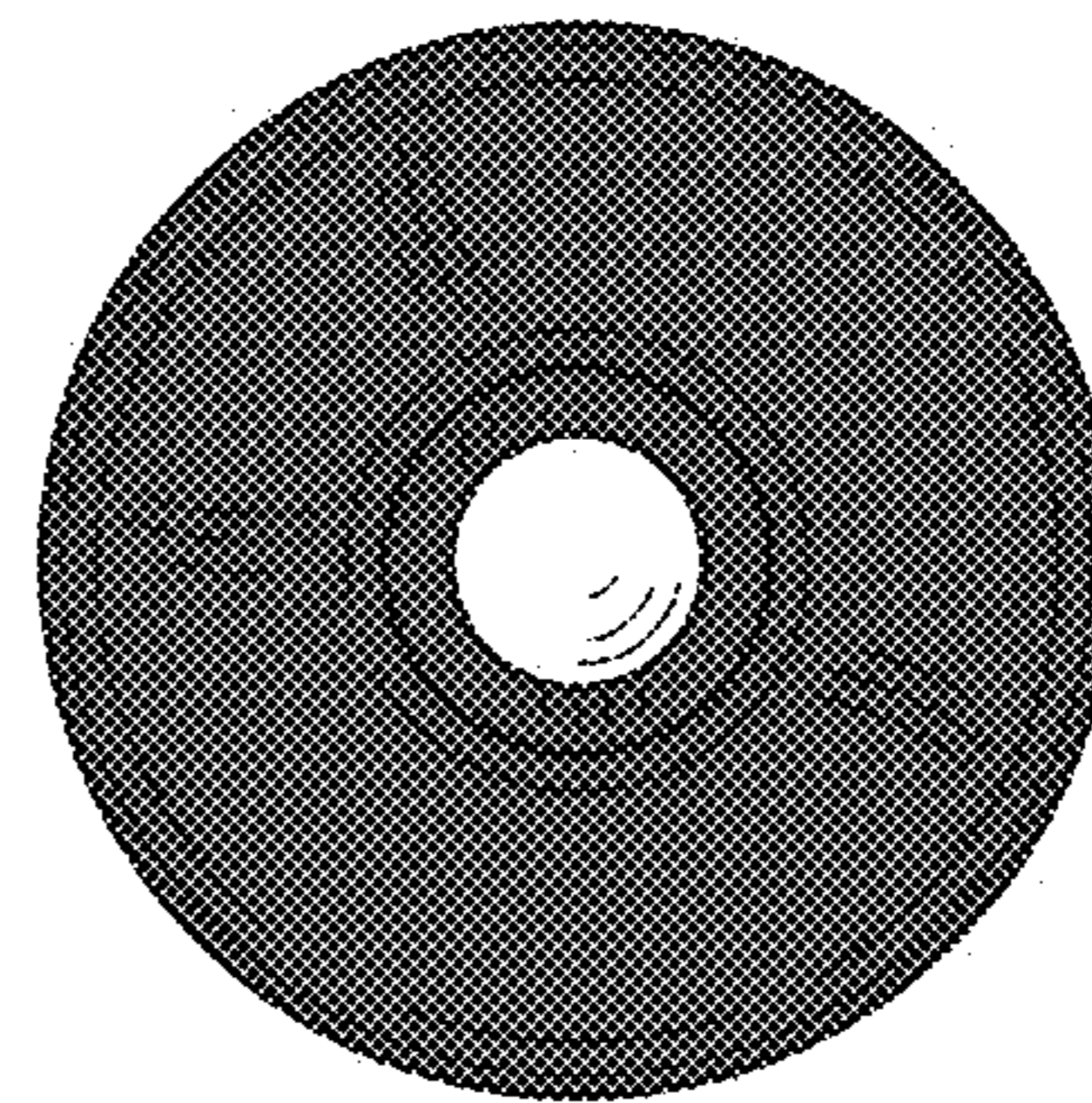

FIG. 19

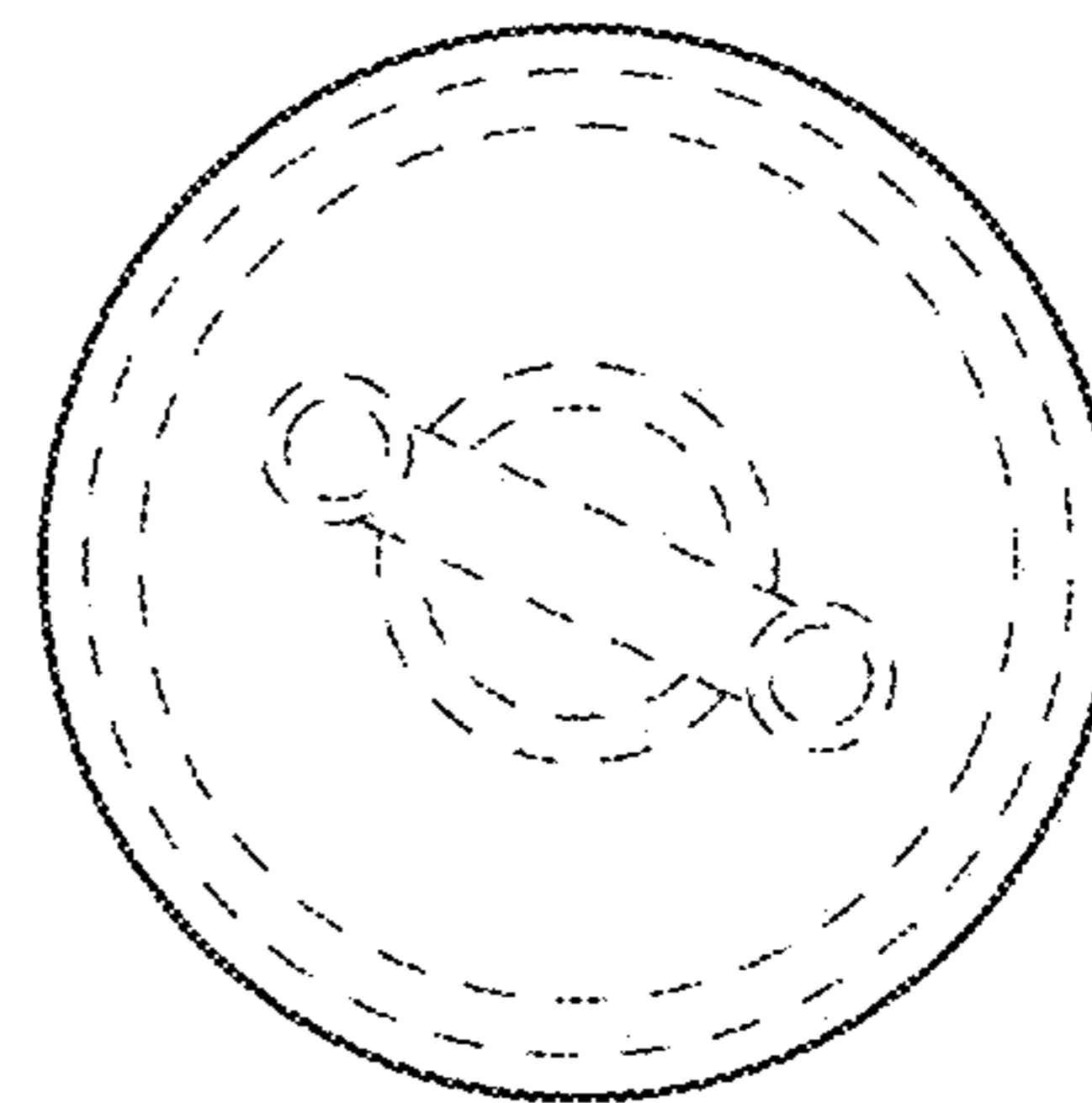

FIG. 20

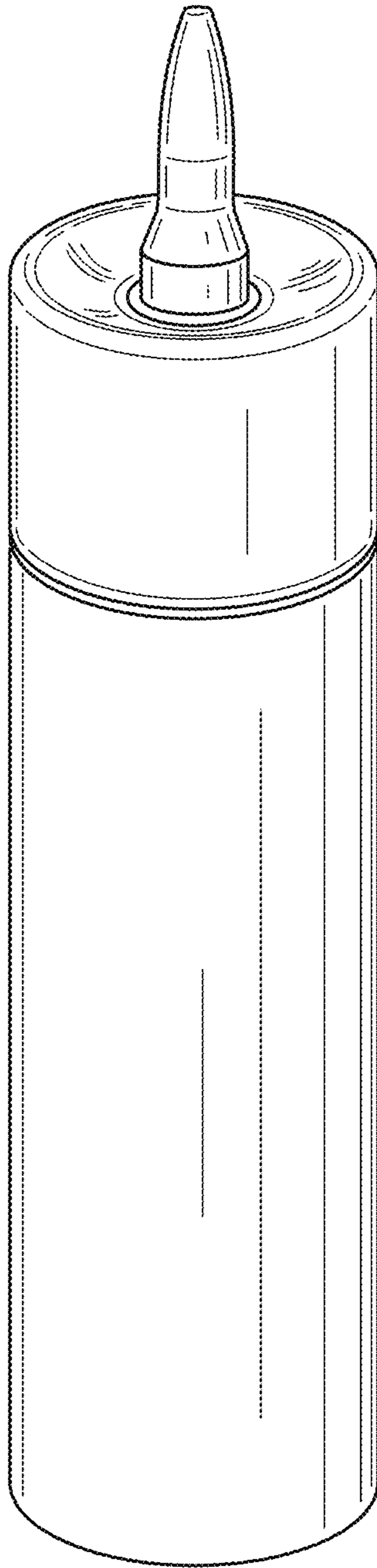

FIG.21

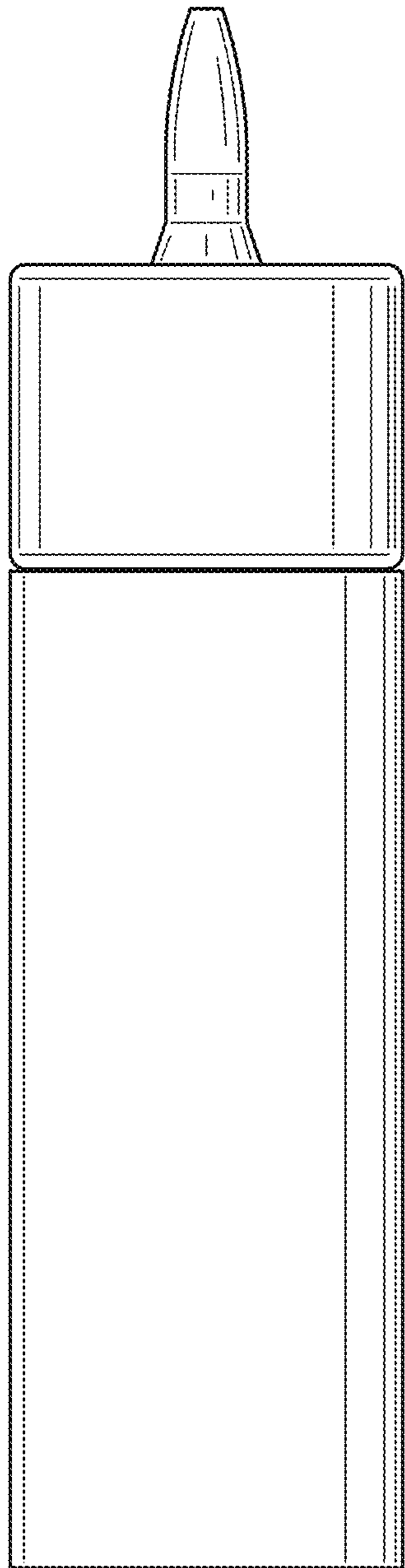

FIG. 22

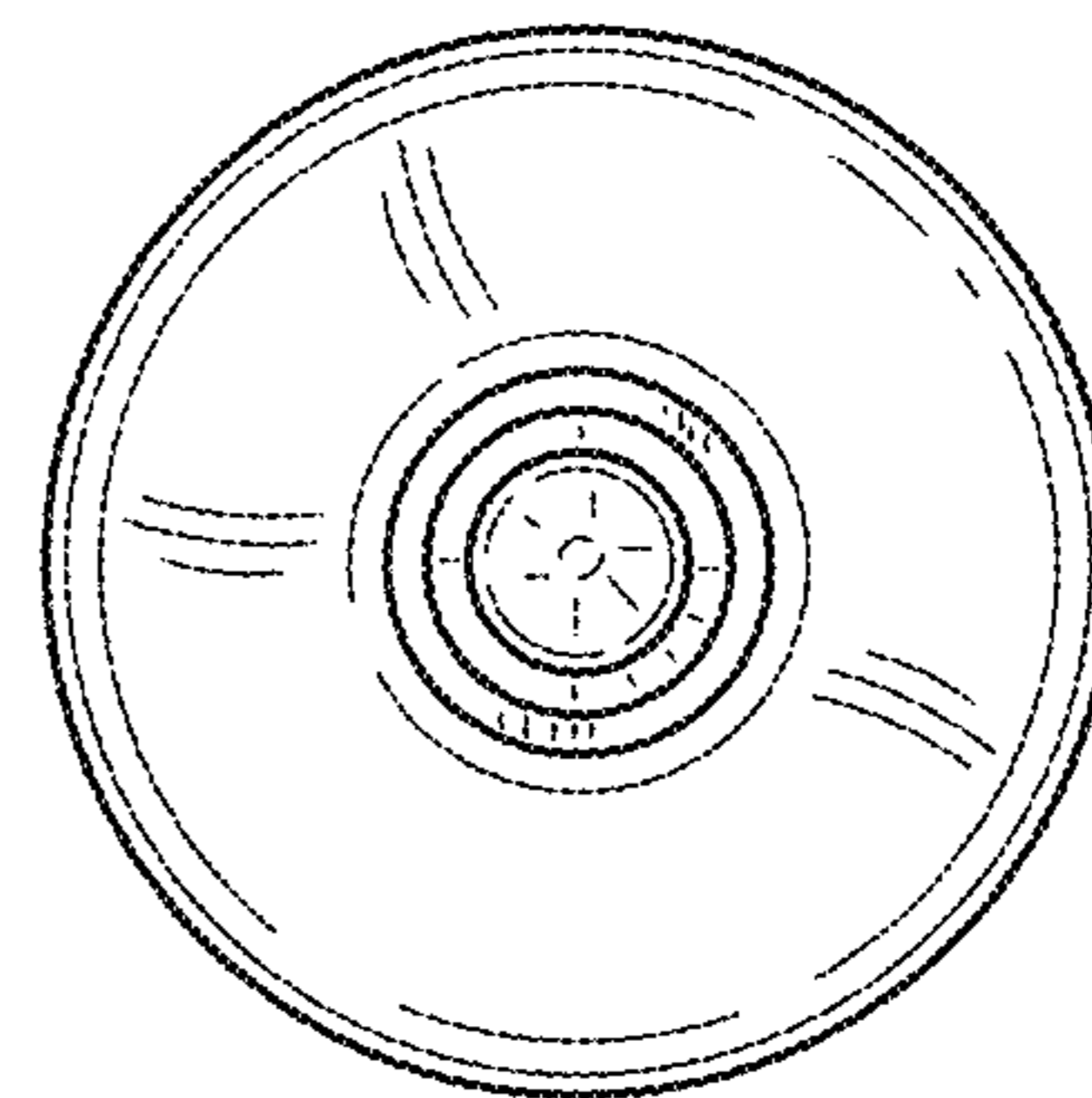

FIG. 23

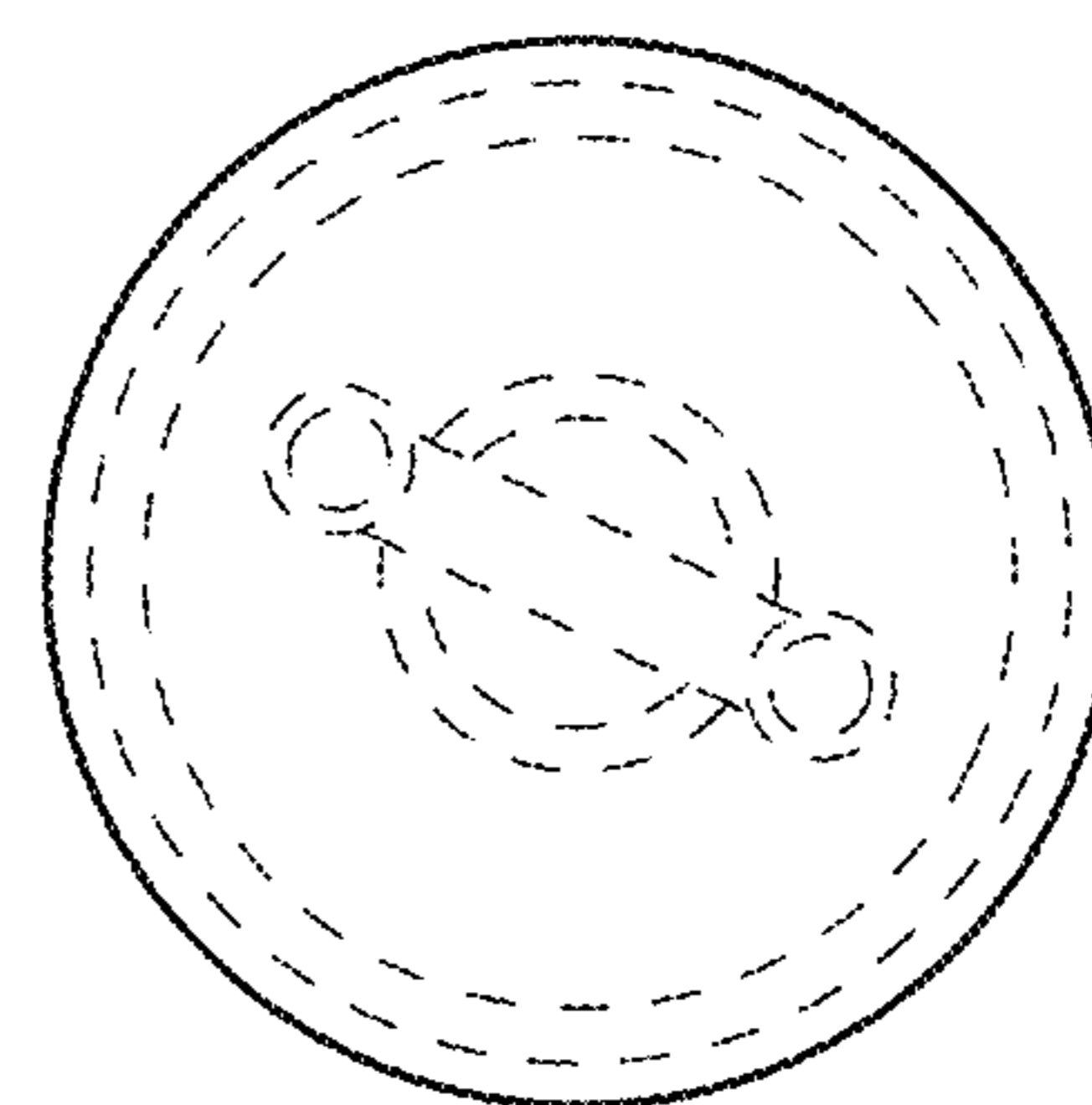

FIG. 24

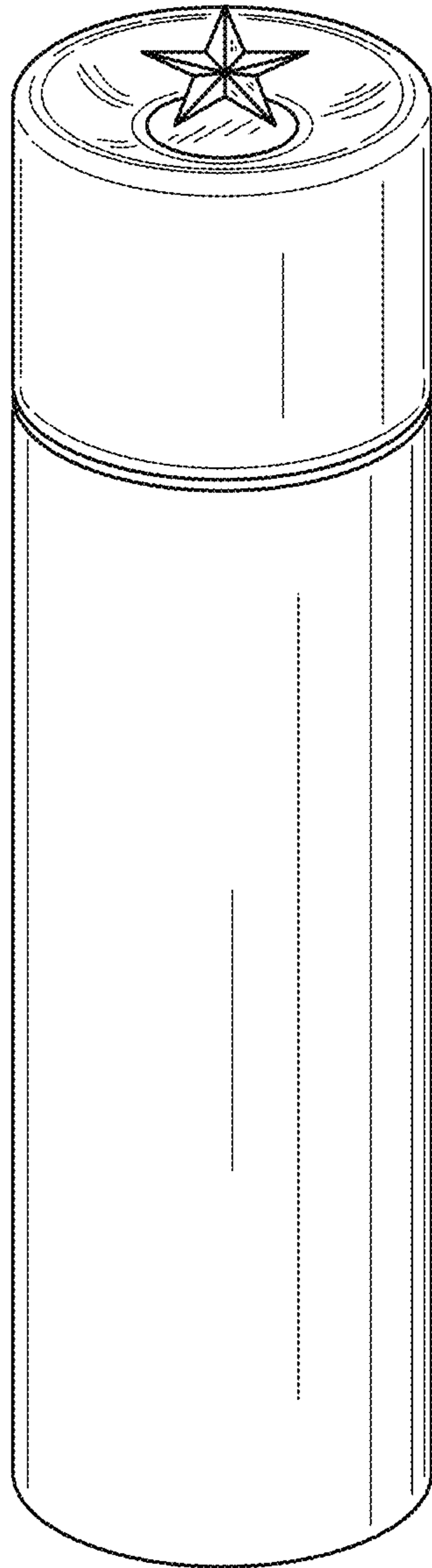

FIG.25

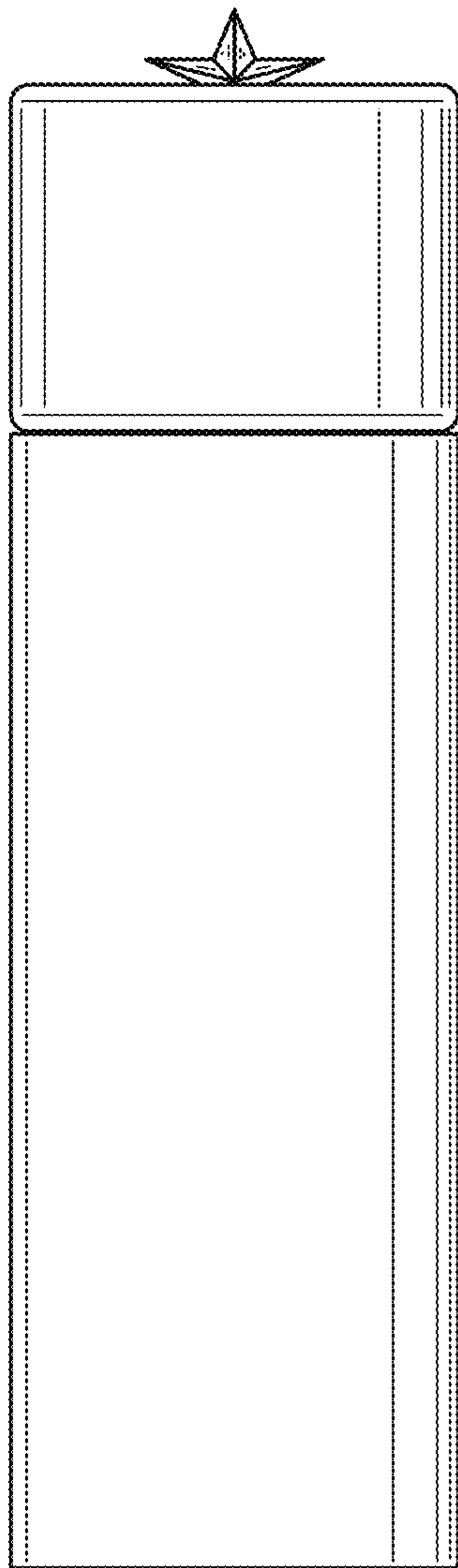

FIG. 26

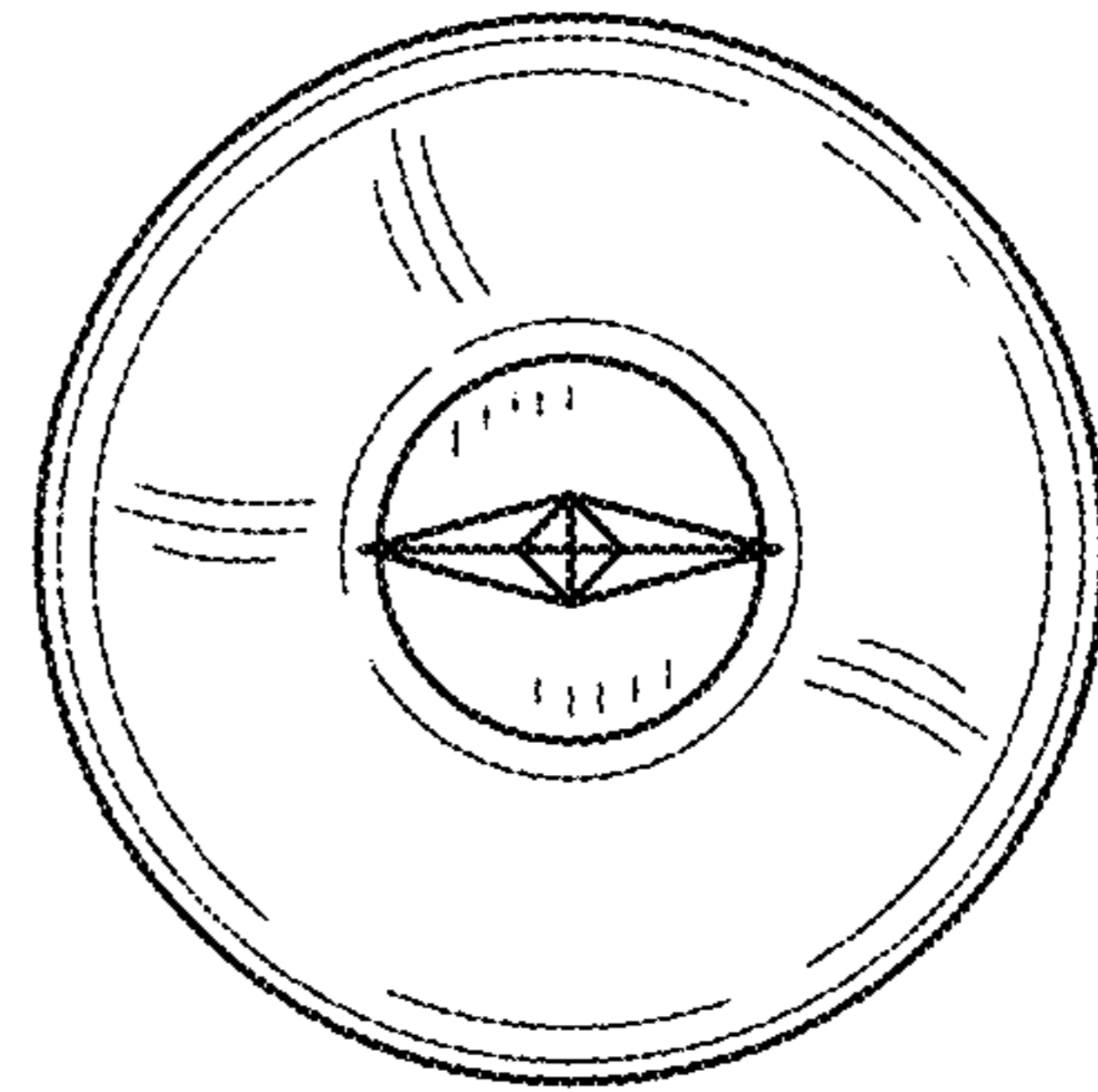

FIG. 27

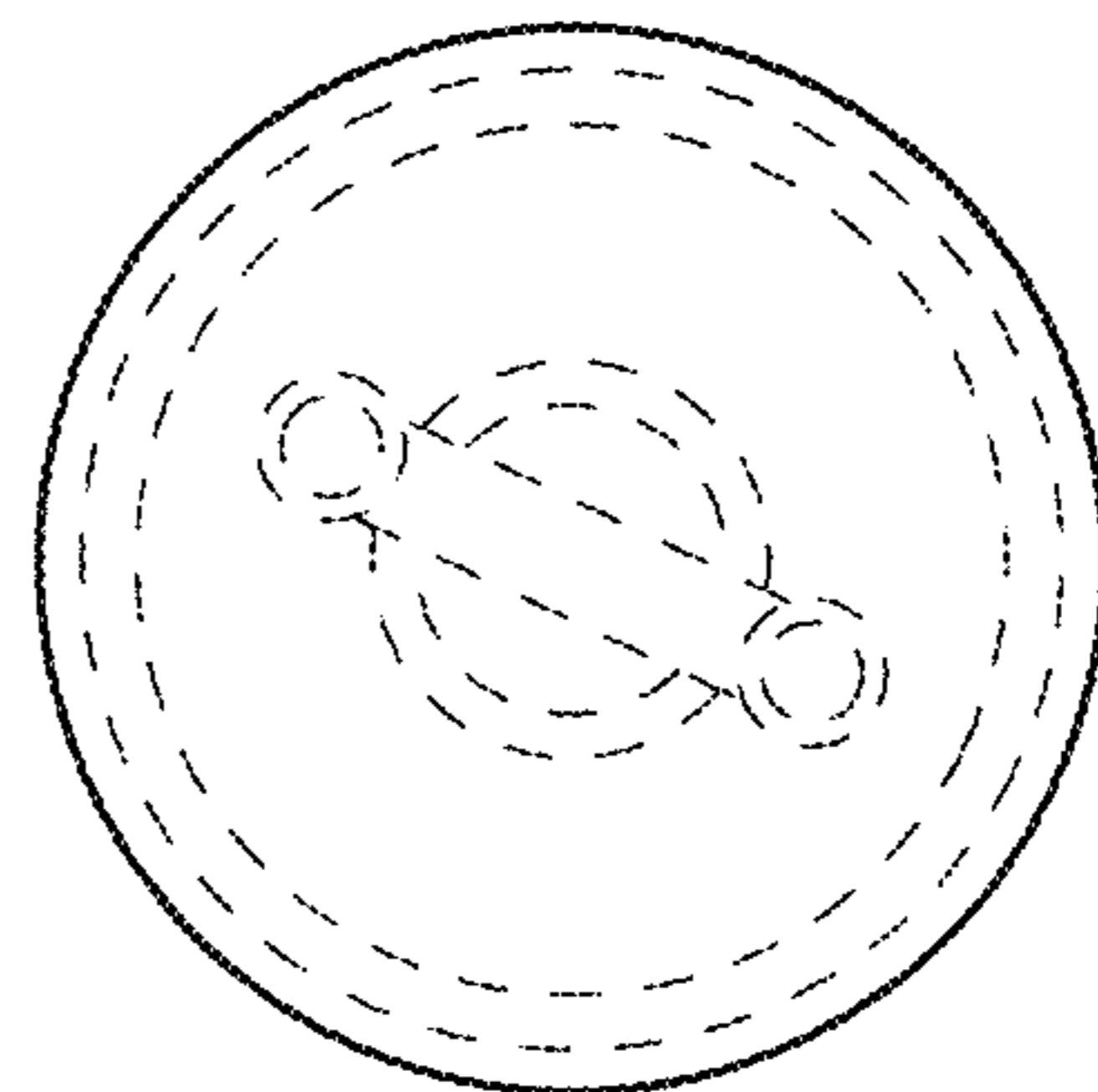

FIG. 28

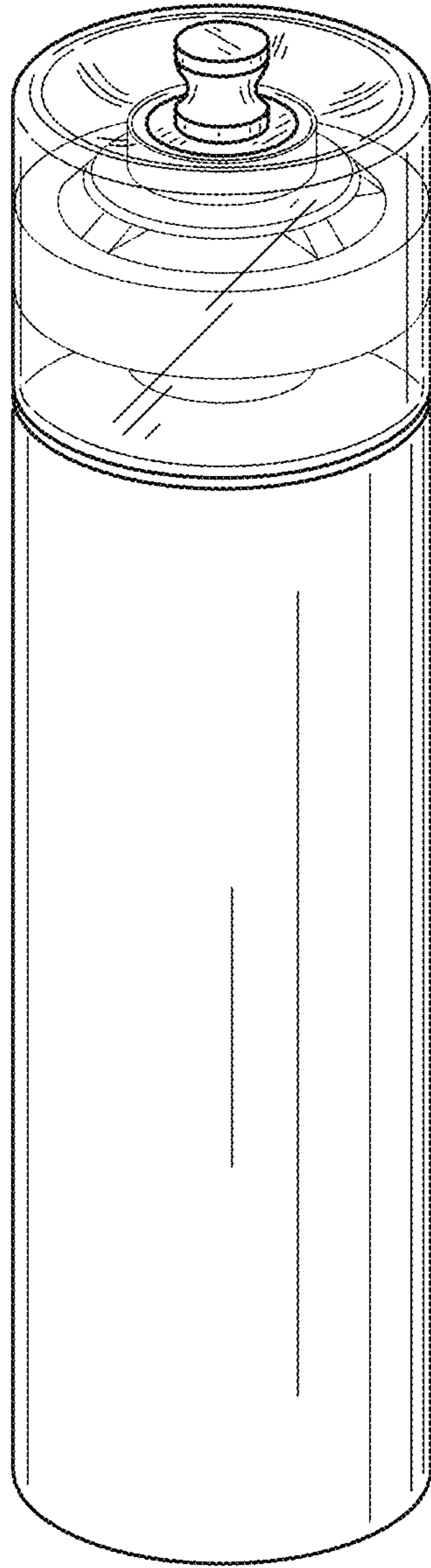

FIG.29

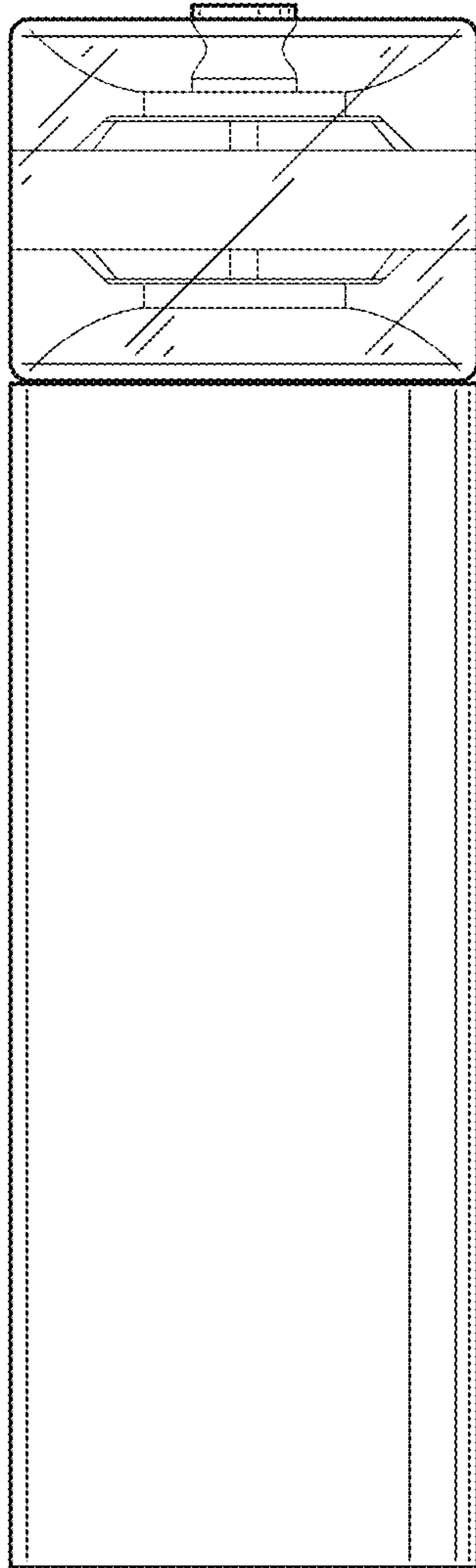

FIG. 30

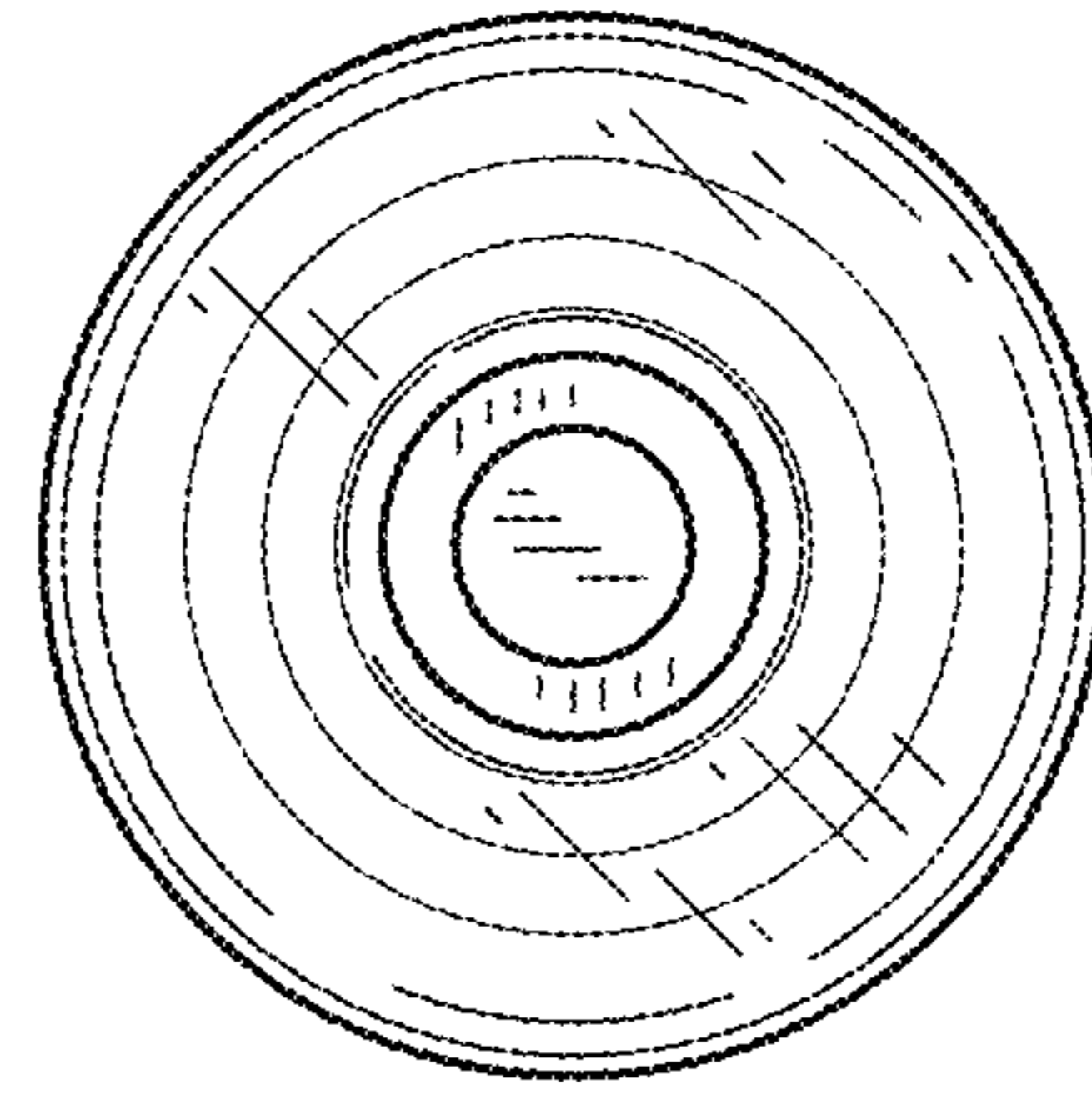

FIG. 31

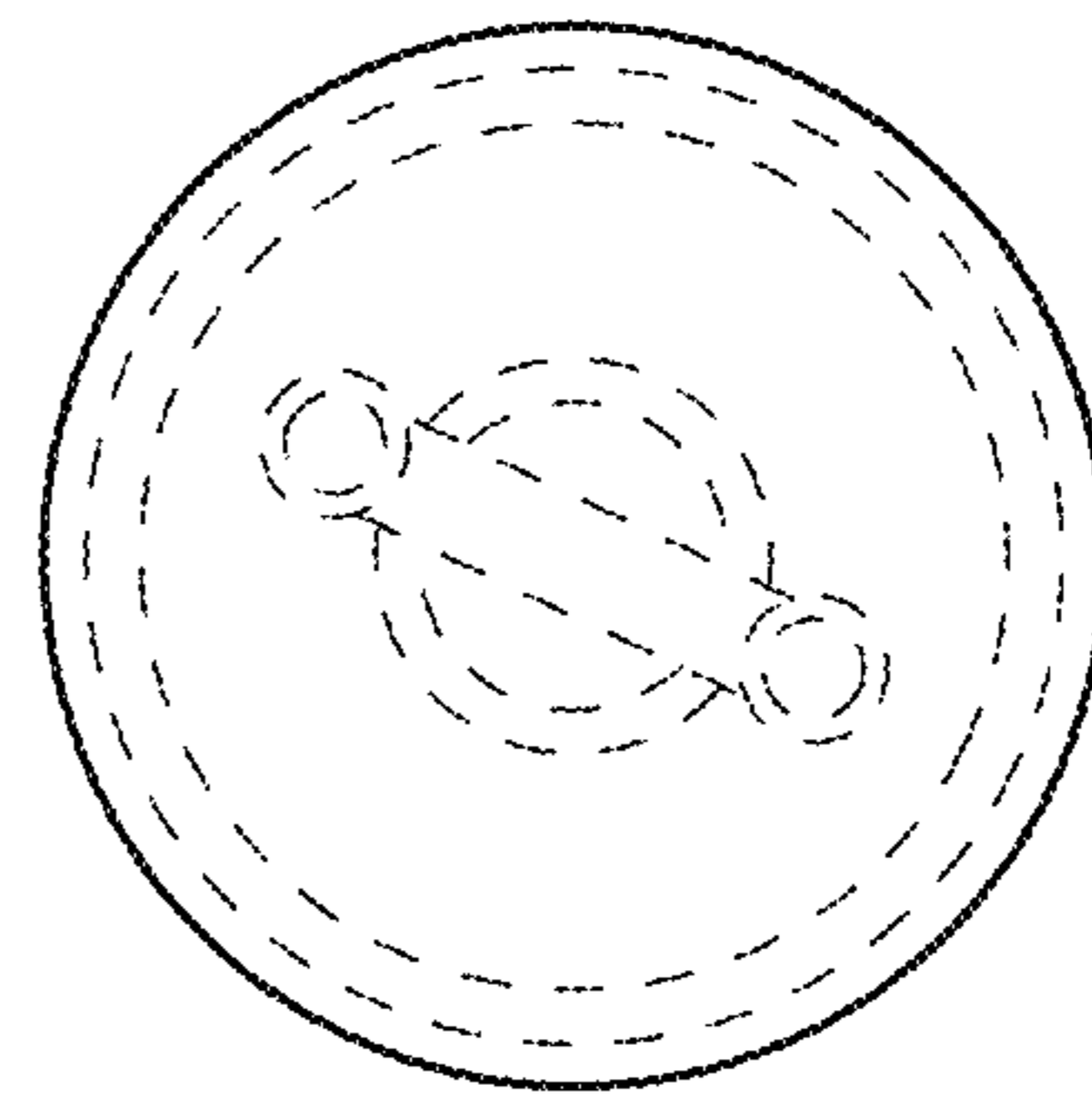

FIG. 32