



US00D786989S

(12) **United States Design Patent** (10) **Patent No.:** **US D786,989 S**  
**Mattern** (45) **Date of Patent:** **\*\* May 16, 2017**

(54) **WEIGHTED SWING TRAINING APPARATUS**

**DESCRIPTION**

(71) Applicant: **Mattern Enterprises, LLC**, Rancho Santa Margarita, CA (US)  
(72) Inventor: **Erik Mattern**, Corona Del Mar, CA (US)  
(73) Assignee: **VARIANCE TECHNOLOGIES, LLC**, Carson City, NV (US)  
(\*\*) Term: **14 Years**  
(21) Appl. No.: **29/511,057**  
(22) Filed: **Dec. 5, 2014**  
(51) **LOC (10) Cl.** ..... **21-02**  
(52) **U.S. Cl.**  
USPC ..... **D21/753**; D21/725; D21/791; D21/680  
(58) **Field of Classification Search**  
USPC ..... D21/722, 725, 789, 791, 680, 682, 684, D21/753; D8/107, 303  
CPC ..... A63B 69/00; A63B 60/00; A63B 59/50; A63B 60/06-60/34; A63B 23/12; A63B 23/06  
See application file for complete search history.

The present application is related to U.S. Pat. No. D669,142, filed Aug. 11, 2011, entitled "Weighted Swing Training Apparatus," to U.S. Design patent application Ser. No. 29/500,634, filed Aug. 27, 2014, entitled "Weighted Swing Training Apparatus," and to U.S. Design patent application Ser. No. 29/506,288, filed Oct. 15, 2014, entitled "Weighted Swing Training Apparatus."  
FIG. 1 is a perspective view of a weighted swing training apparatus showing my design in accordance with a first embodiment;  
FIG. 2 is a front elevational view of the weighted swing training apparatus of the first embodiment;  
FIG. 3 is a rear elevational view of the weighted swing training apparatus of the first embodiment;  
FIG. 4 is a left side elevational view of the weighted swing training apparatus of the first embodiment;  
FIG. 5 is a right side elevational view of the weighted swing training apparatus of the first embodiment;  
FIG. 6 is a top plan view of the weighted swing training apparatus of the first embodiment;  
FIG. 7 is a bottom plan view of the weighted swing training apparatus of the first embodiment;  
FIG. 8 is a perspective view of a weighted swing training apparatus showing my design in accordance with a second embodiment;  
FIG. 9 is a front elevational view of the weighted swing training apparatus of the second embodiment;  
FIG. 10—is a rear elevational view of the weighted swing training apparatus of the second embodiment;  
FIG. 11 is a left side elevational view of the weighted swing training apparatus of the second embodiment;  
FIG. 12 is a right side elevational view of the weighted swing training apparatus of the second embodiment;  
FIG. 13 is a top plan view of the weighted swing training apparatus of the second embodiment; and,  
FIG. 14 is a bottom plan view of the weighted swing training apparatus of the second embodiment.

(56) **References Cited**

**U.S. PATENT DOCUMENTS**

1,229,658 A \* 6/1917 Sandow ..... A63B 21/0726 43/23  
2,983,638 A 5/1961 Quehl, Jr.  
3,330,560 A 7/1967 Higdon  
3,392,976 A 7/1968 Hayes

(Continued)

*Primary Examiner* — Mitchell Siegel  
(74) *Attorney, Agent, or Firm* — William L. Chapin

(57) **CLAIM**

The ornamental design for a weighted swing training apparatus, as shown.

**1 Claim, 14 Drawing Sheets**

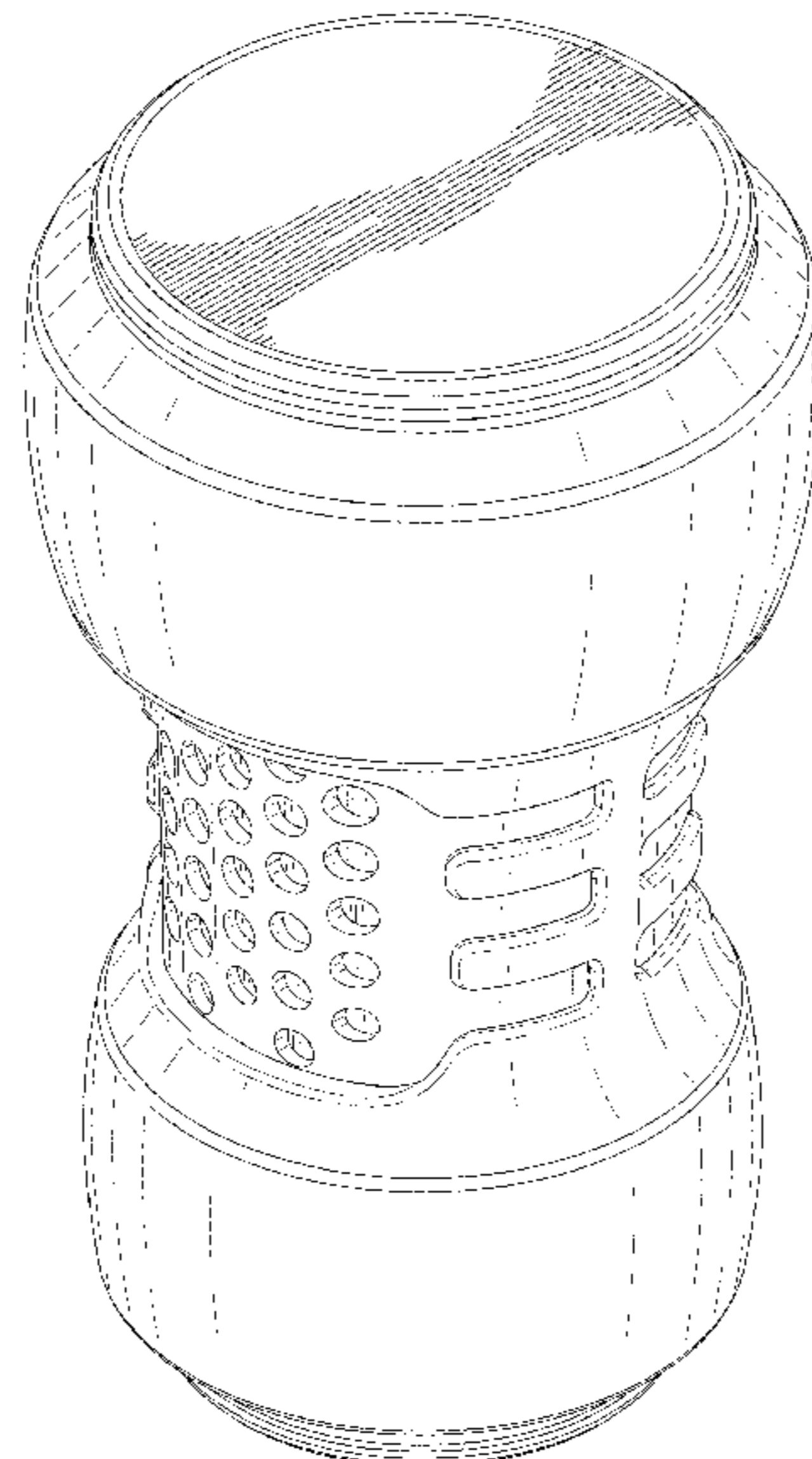

(56)

References Cited

U.S. PATENT DOCUMENTS

3,414,260 A 12/1968 Gust  
 3,623,724 A 11/1971 Lande  
 5,024,436 A 6/1991 Vento  
 5,050,877 A \* 9/1991 Wales ..... A63B 69/0002  
 473/437  
 D337,505 S \* 7/1993 Ming-Chang ..... D8/303  
 D341,403 S \* 11/1993 Wilkinson ..... D21/684  
 5,418,980 A \* 5/1995 Kelly ..... A41D 20/00  
 2/16  
 5,980,397 A 11/1999 Hart et al.  
 6,190,271 B1 2/2001 Rappaport et al.  
 D450,793 S \* 11/2001 Dantolan ..... D21/680  
 D458,679 S \* 6/2002 Thompson ..... D24/133  
 D465,715 S \* 11/2002 Chiang ..... D8/107  
 6,533,685 B1 \* 3/2003 Otten ..... A63B 59/50  
 473/437  
 D483,827 S \* 12/2003 Ciesar ..... D21/725  
 6,739,989 B2 5/2004 Liberatore  
 D492,373 S \* 6/2004 Sonnon ..... D21/662  
 7,128,667 B2 10/2006 Nolan

D534,411 S \* 1/2007 Kuo ..... D21/679  
 7,344,457 B2 \* 3/2008 Liberatore ..... A63B 15/00  
 473/422  
 7,686,711 B2 \* 3/2010 Miller ..... A63B 69/0002  
 473/422  
 D627,841 S \* 11/2010 Estrada, Jr. .... D21/753  
 8,231,484 B1 7/2012 Quinn  
 D669,142 S \* 10/2012 Mattern ..... D21/680  
 D759,769 S \* 6/2016 Mattern ..... D21/680  
 2004/0063519 A1 4/2004 Liberatore  
 2004/0209711 A1 \* 10/2004 Liberatore ..... A63B 15/00  
 473/457  
 2006/0025246 A1 2/2006 Froney et al.  
 2006/0084530 A1 4/2006 Cheeseman  
 2007/0123371 A1 5/2007 Liberatore  
 2008/0108457 A1 \* 5/2008 Hansen ..... A63B 59/50  
 473/437  
 2008/0261729 A1 10/2008 Mullin  
 2009/0069126 A1 3/2009 Merchant  
 2010/0137078 A1 6/2010 Liberatore  
 2013/0023360 A1 \* 1/2013 Mattern ..... A63B 69/0002  
 473/437

\* cited by examiner

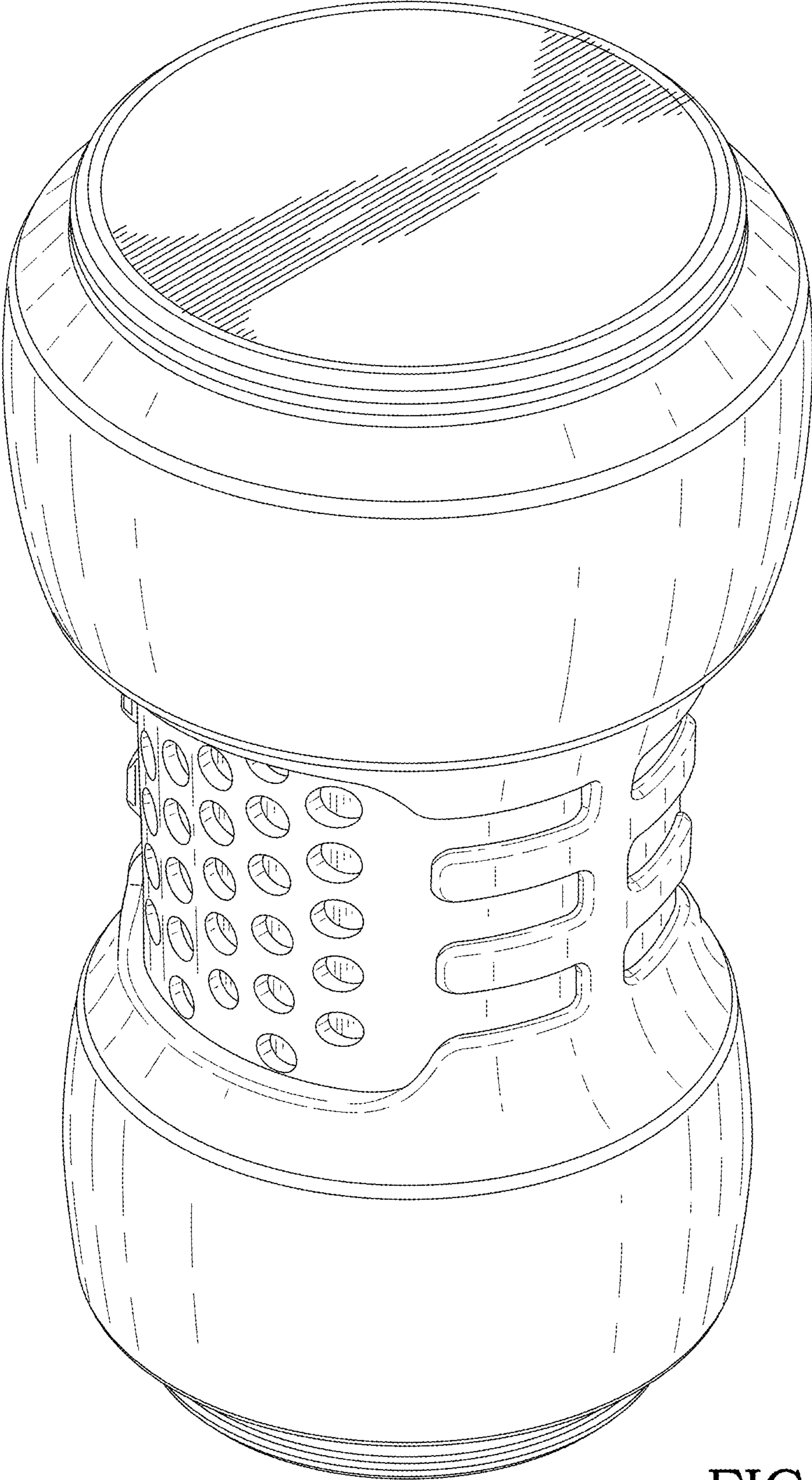

FIG. 1

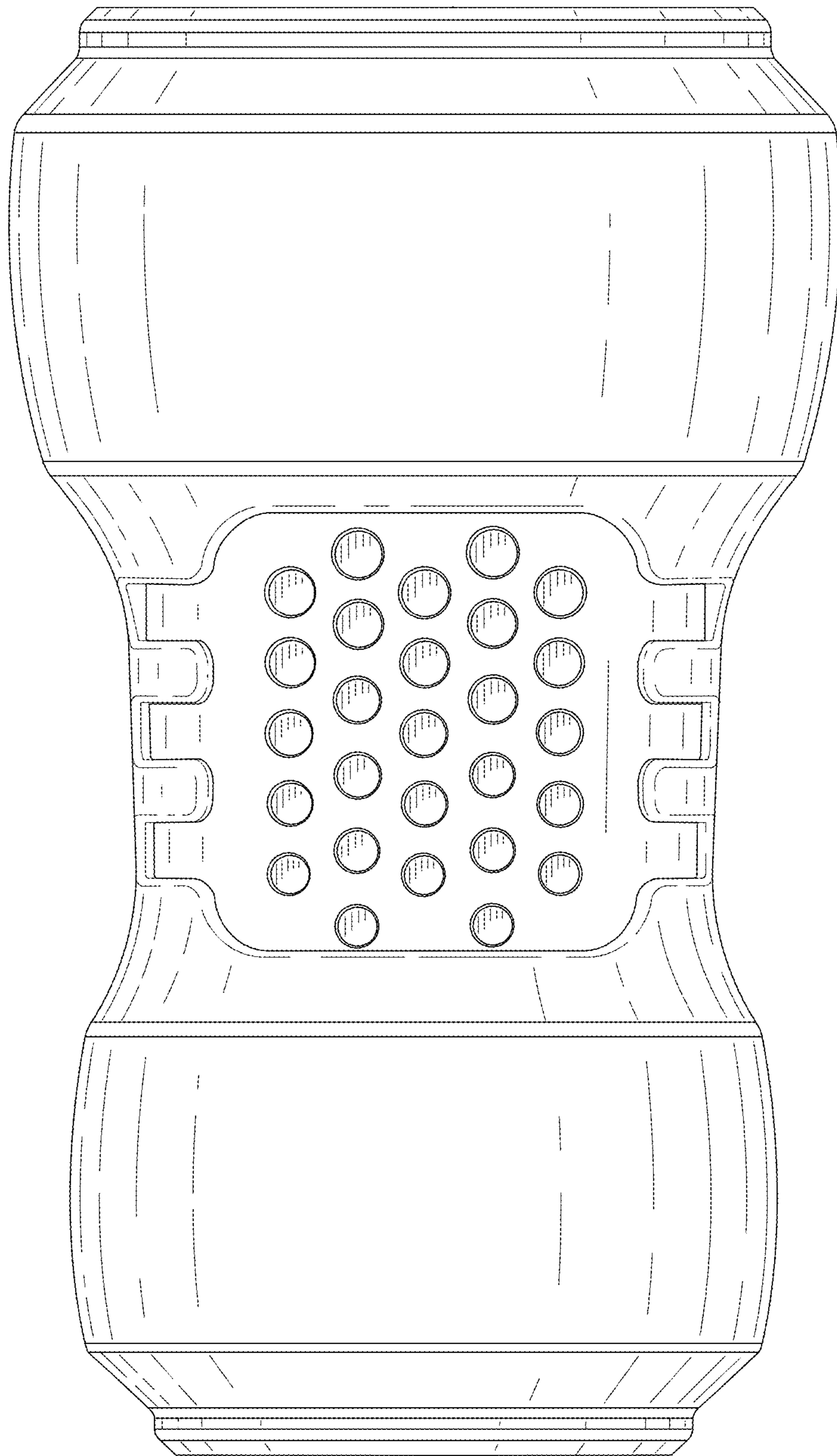

FIG. 2

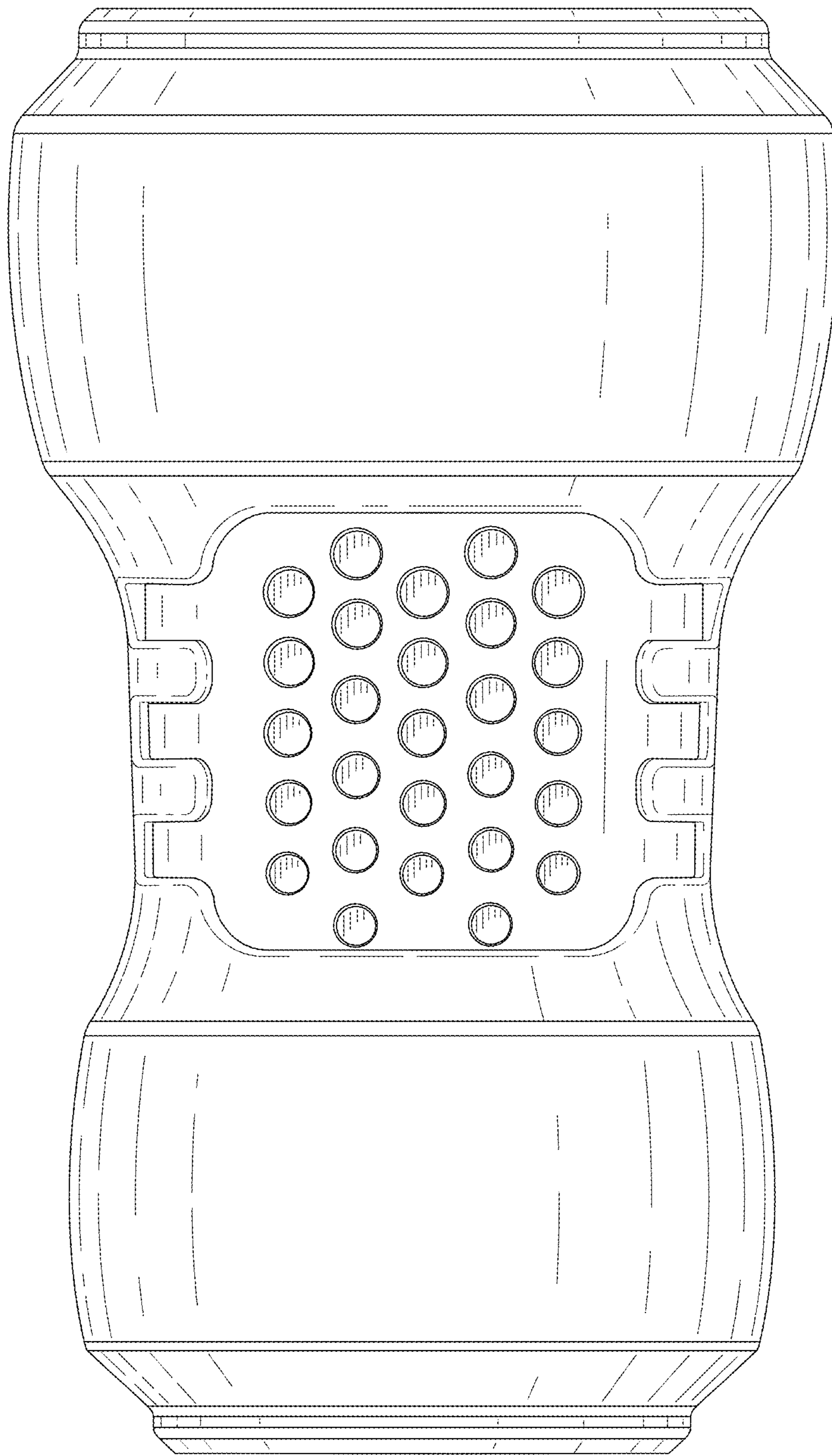

FIG. 3

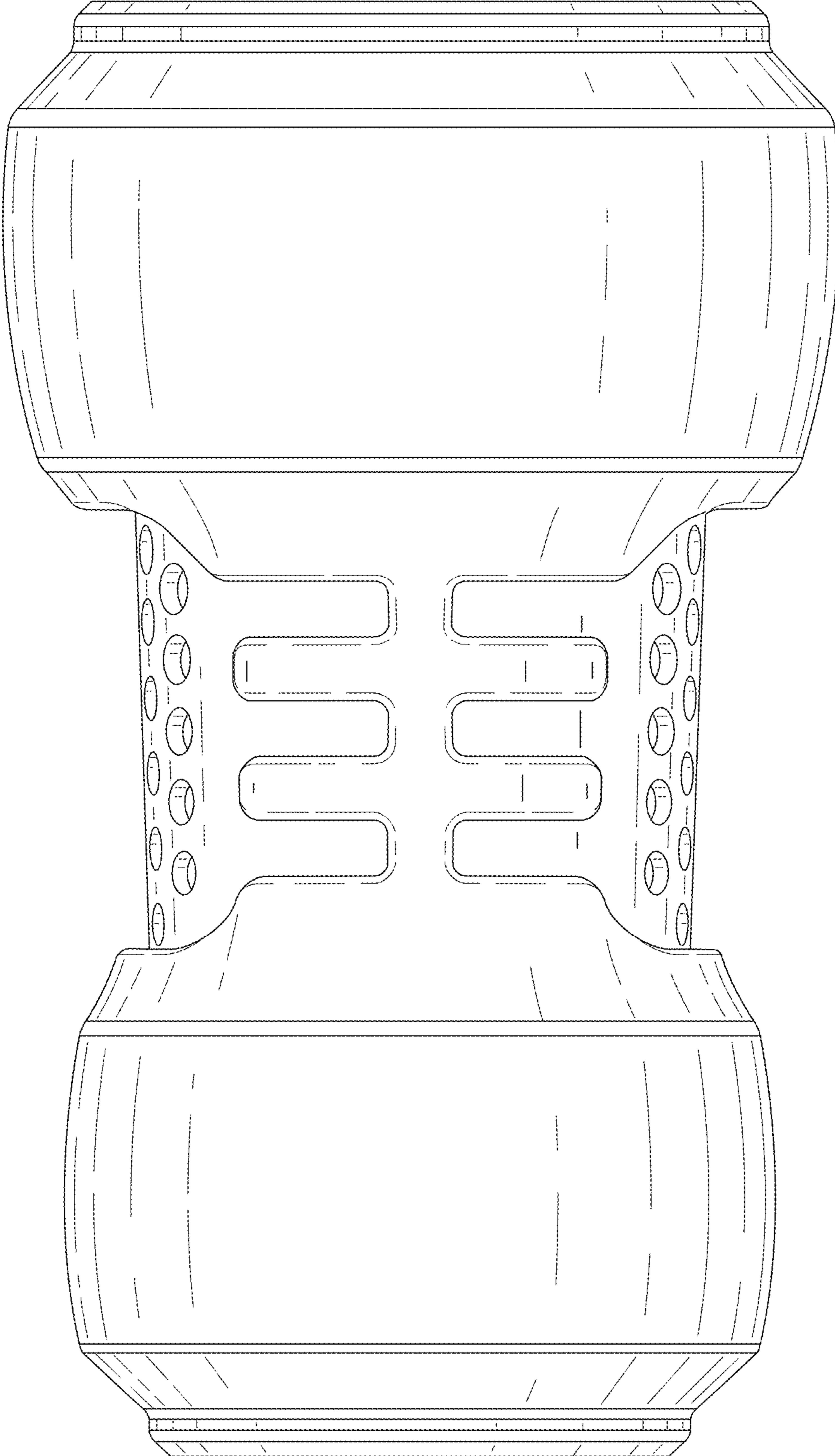

FIG. 4

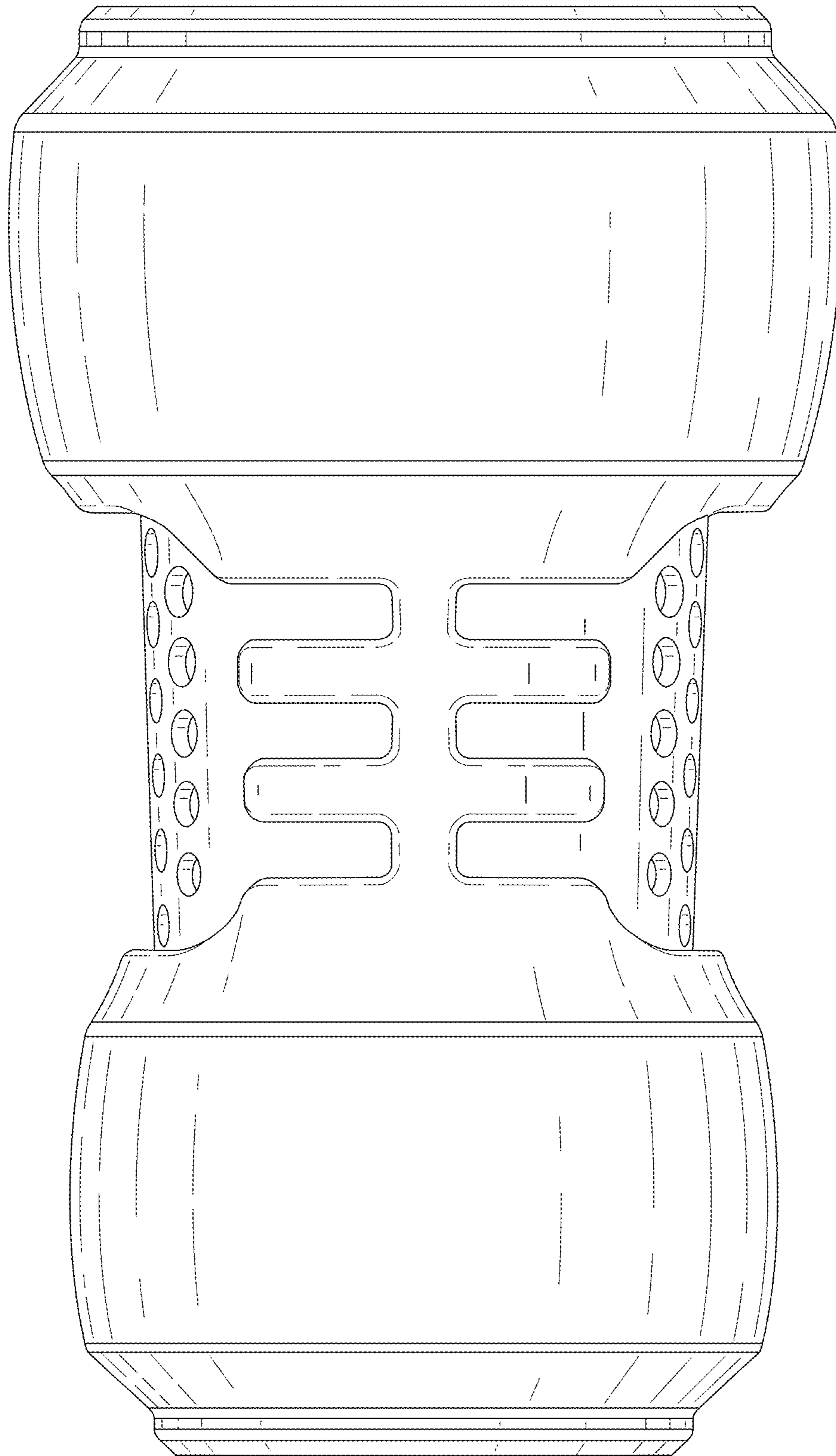

FIG. 5

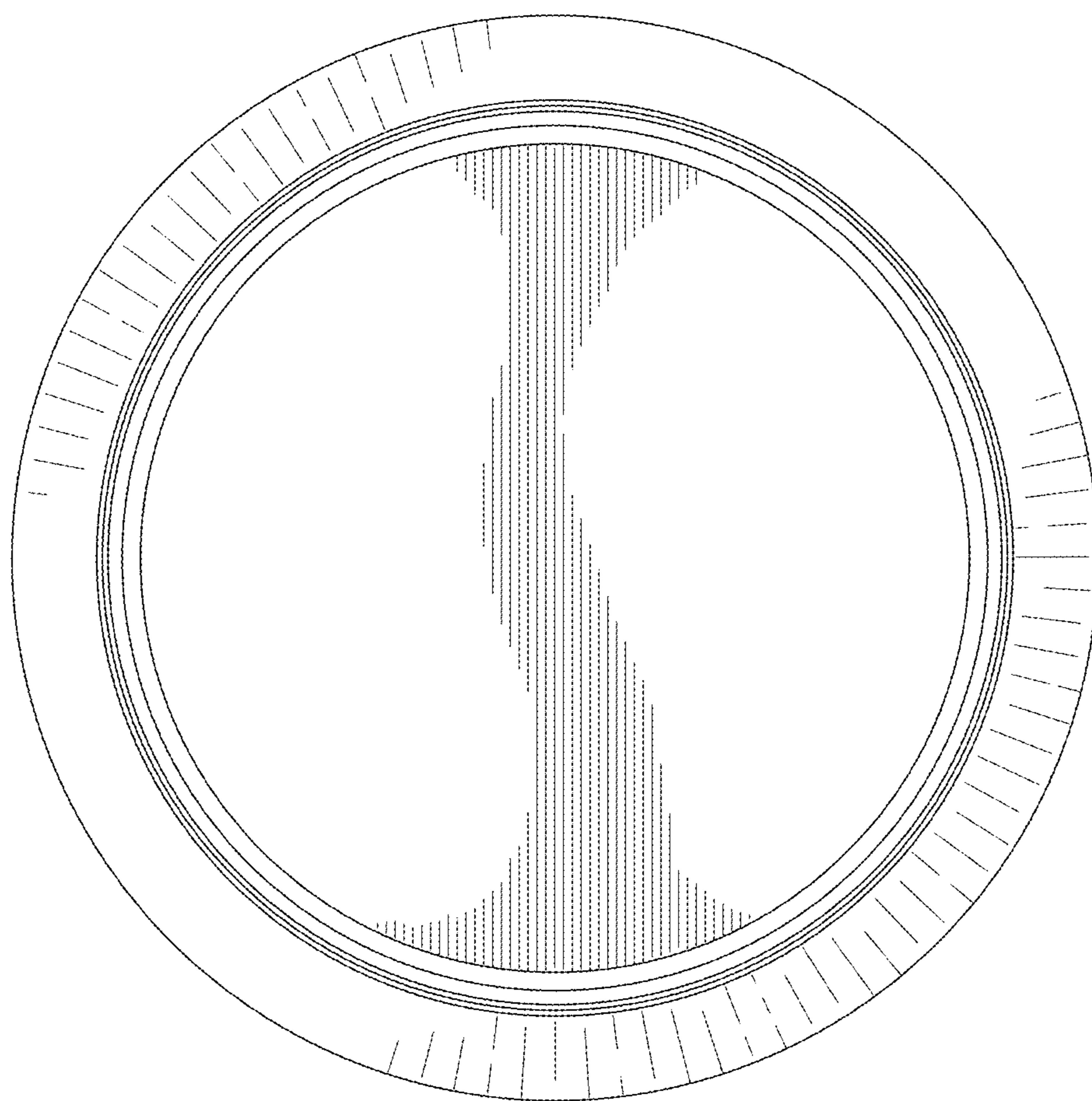

FIG. 6



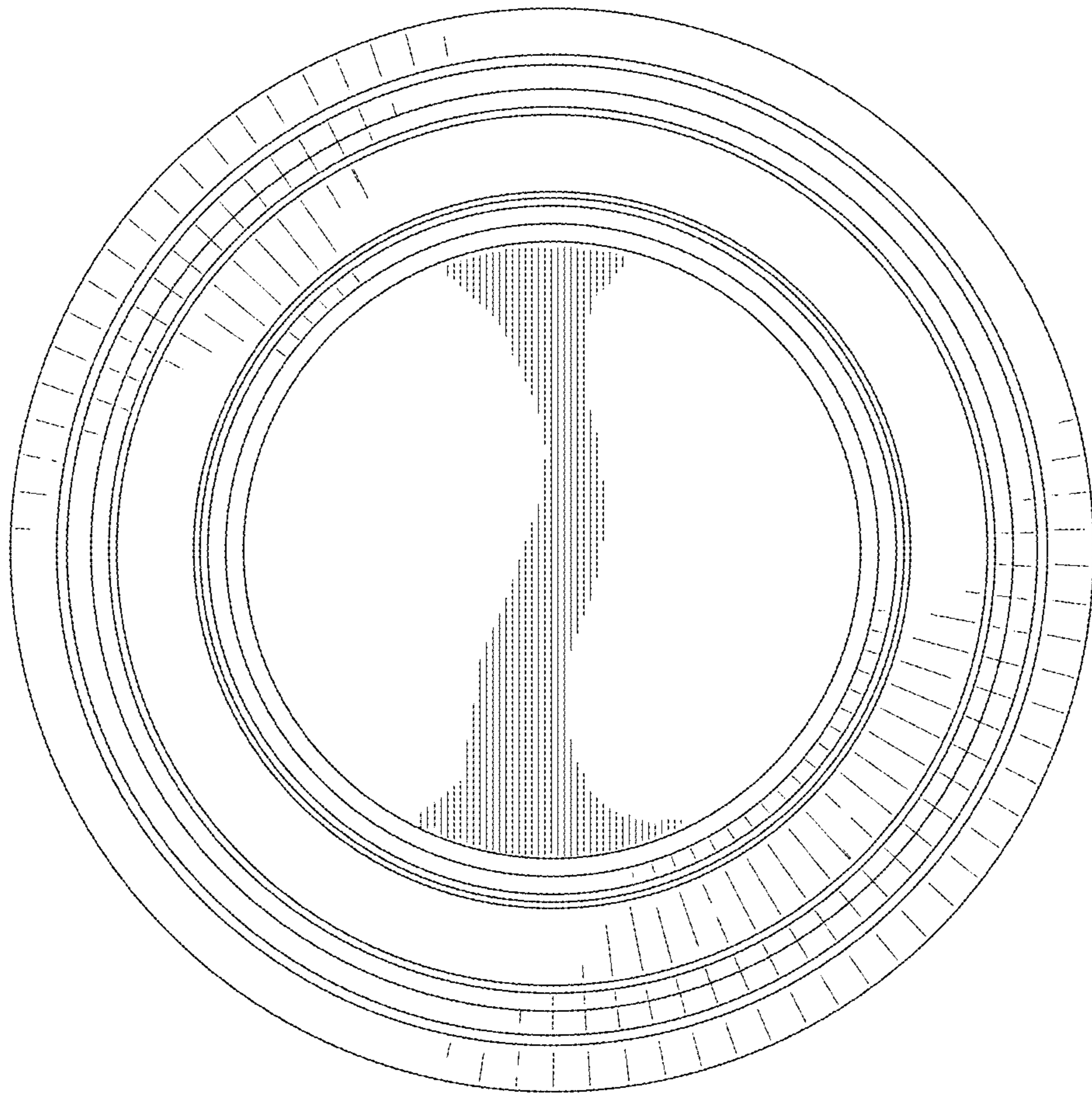

FIG. 7

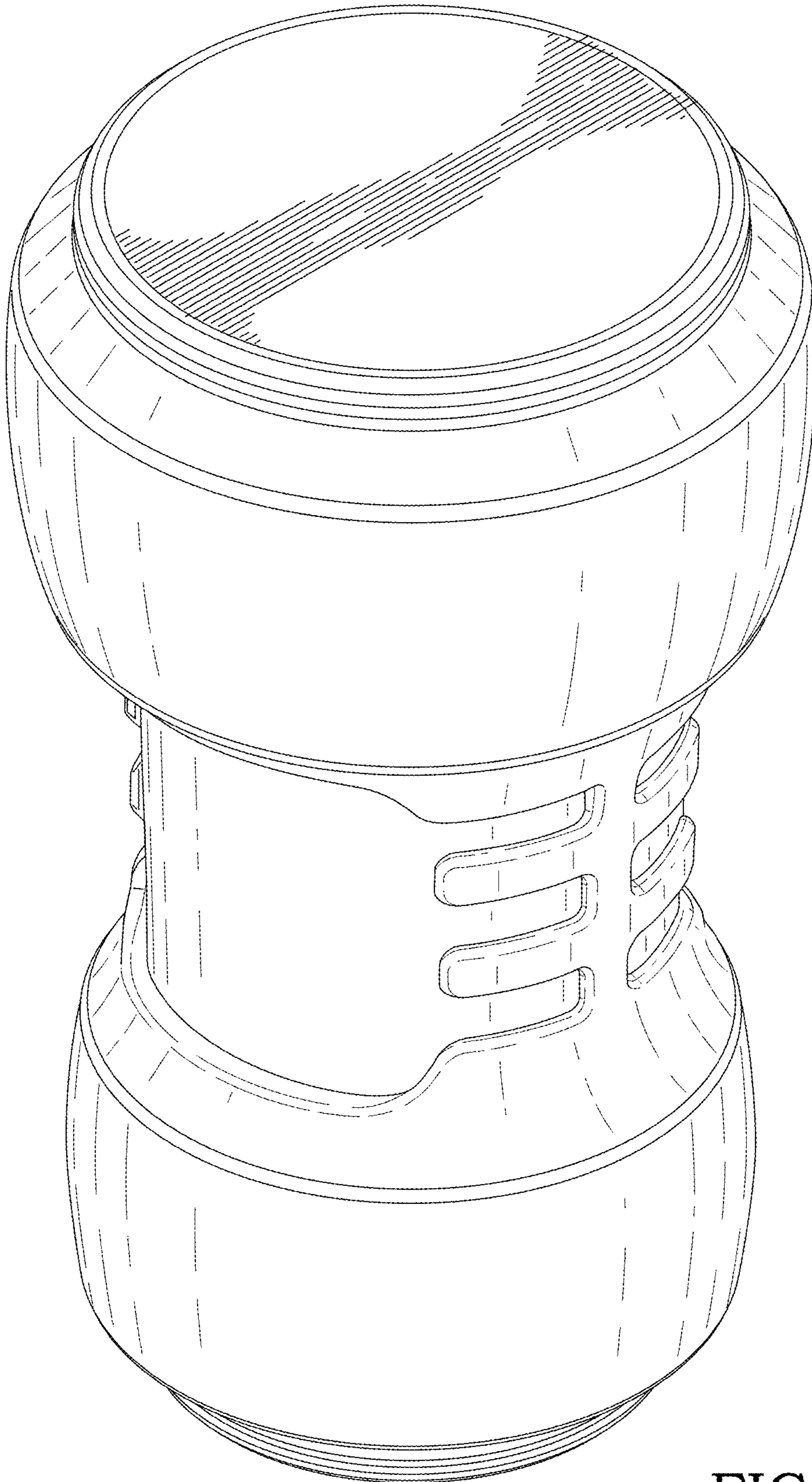

FIG. 8

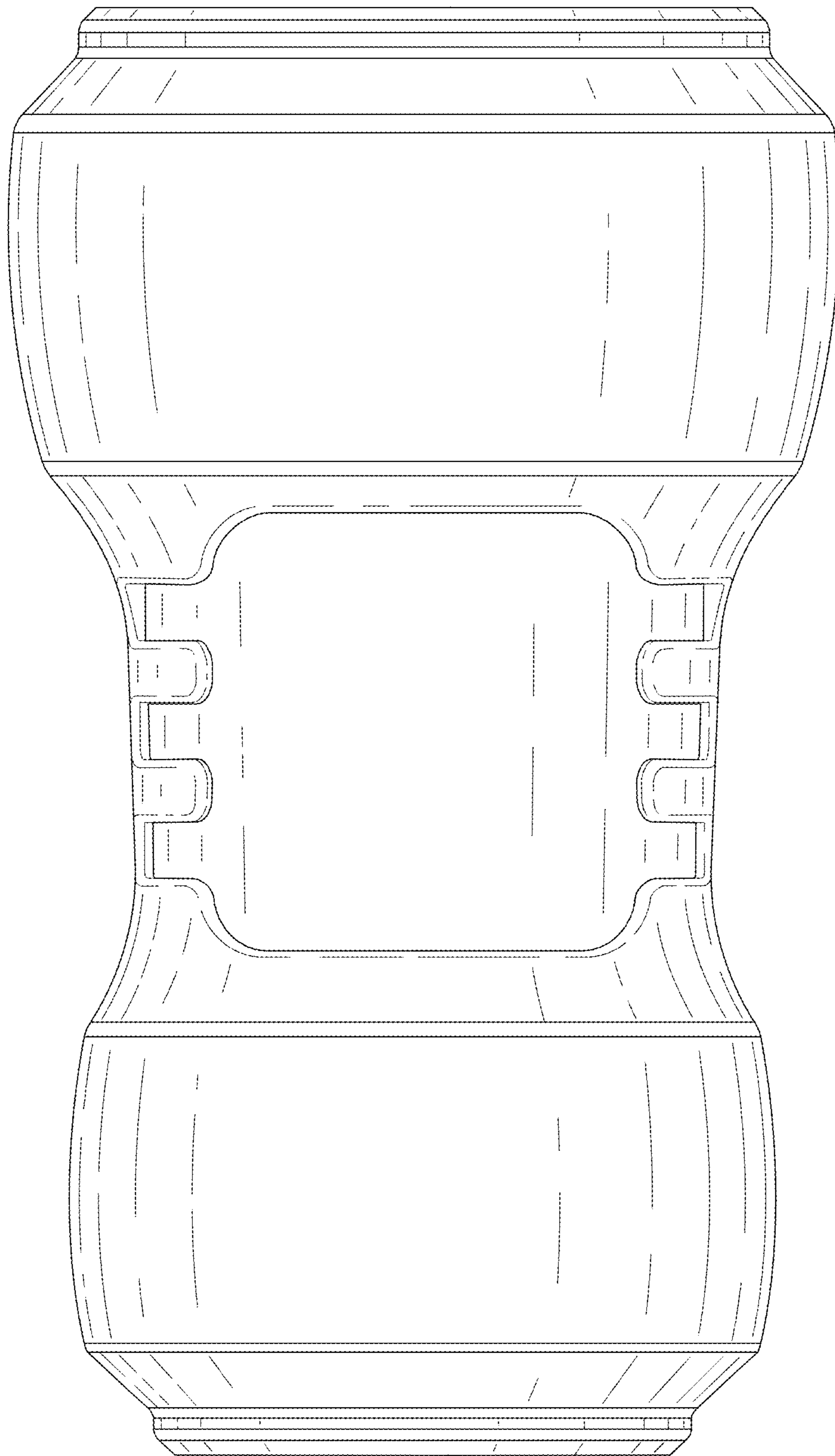

FIG. 9

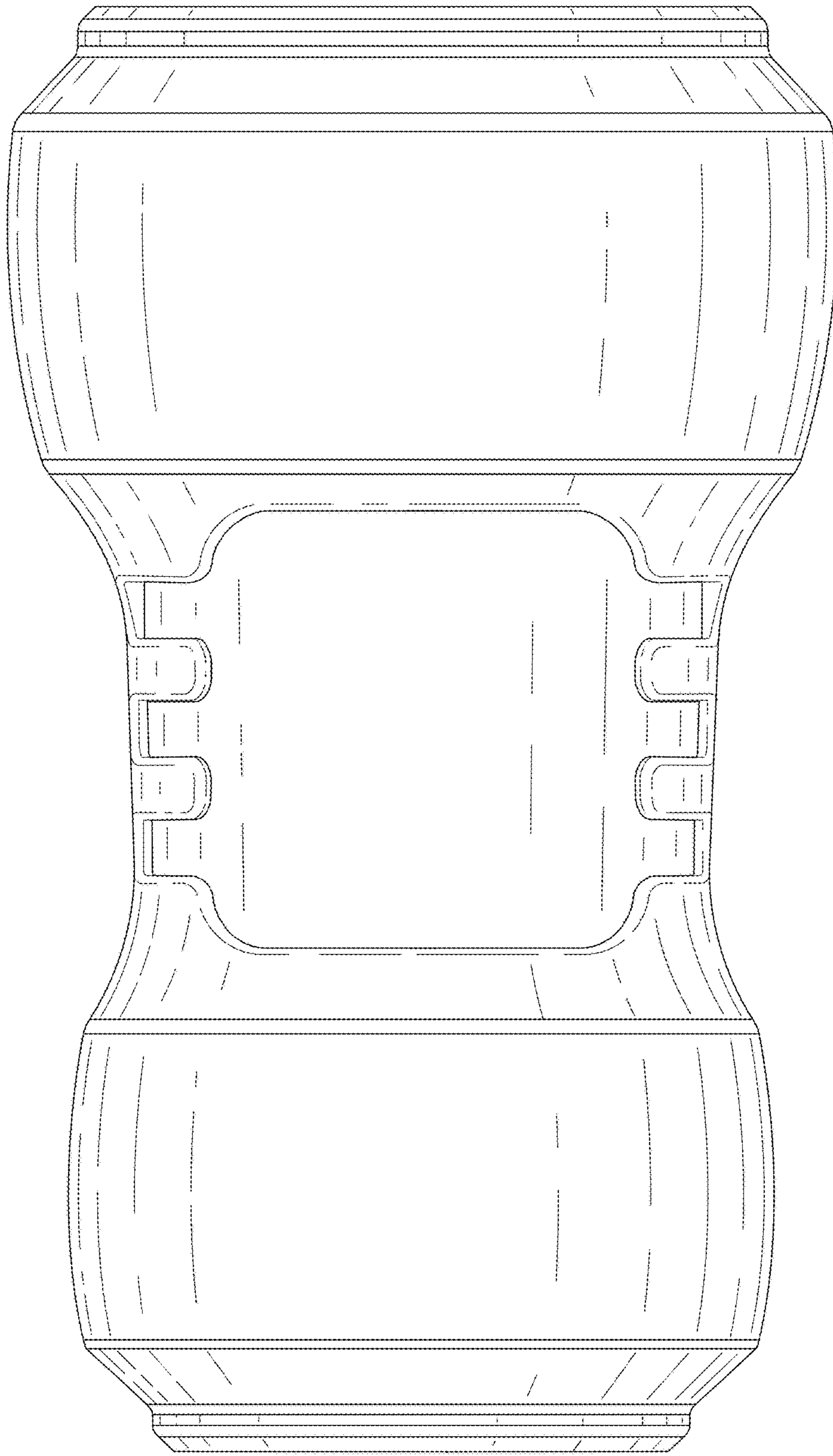

FIG. 10

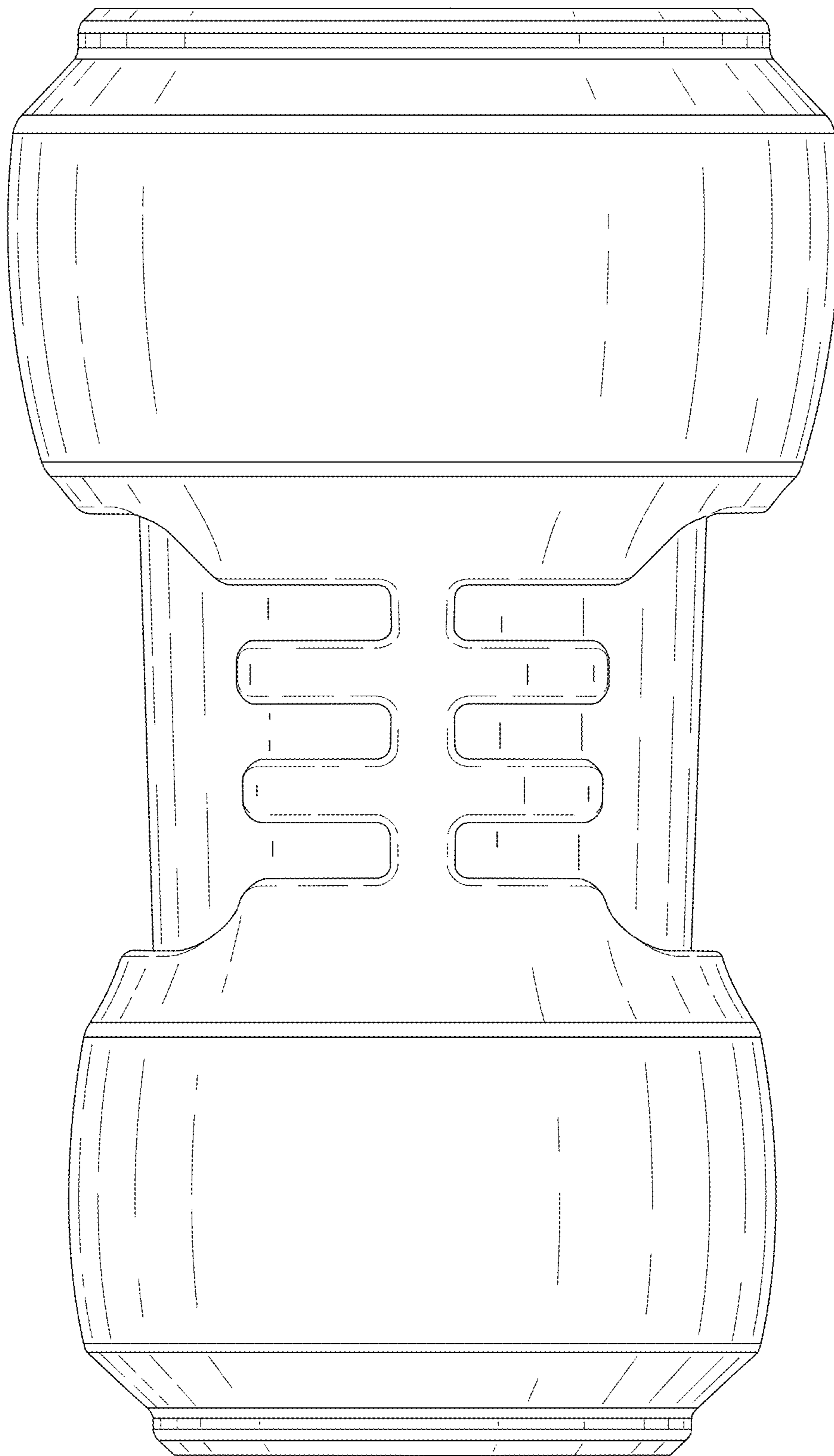

FIG. 11

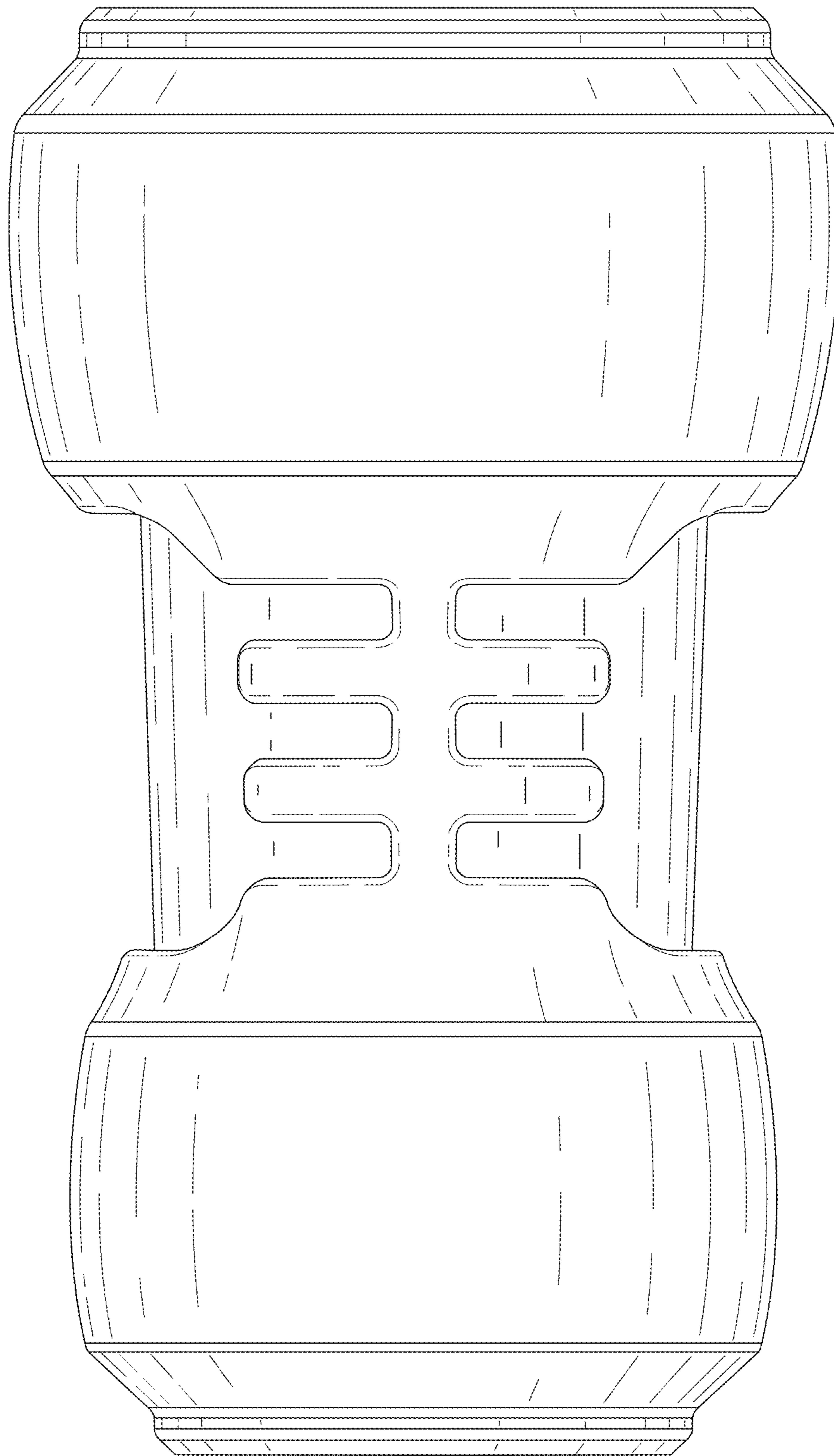

FIG. 12

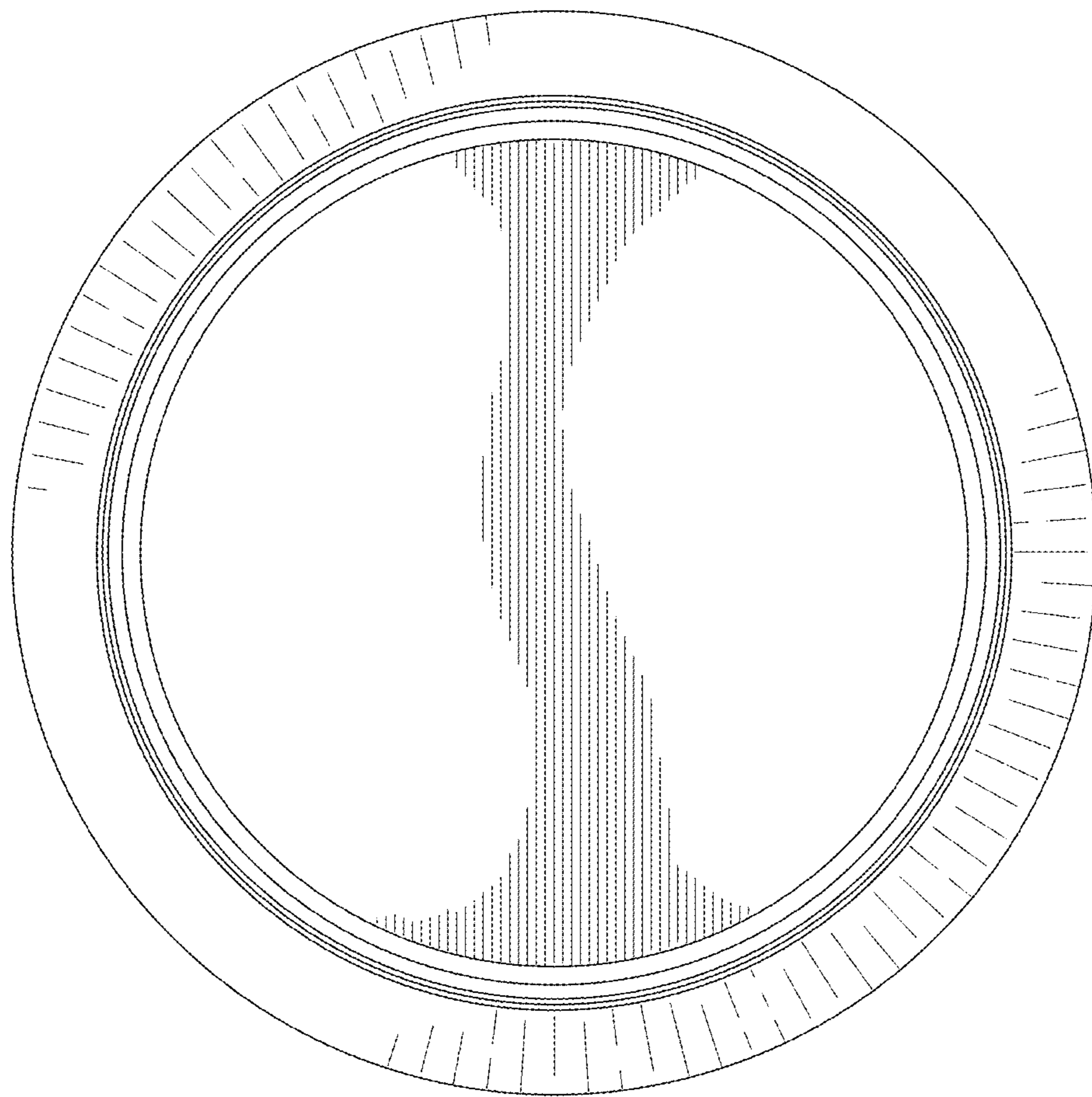

FIG. 13

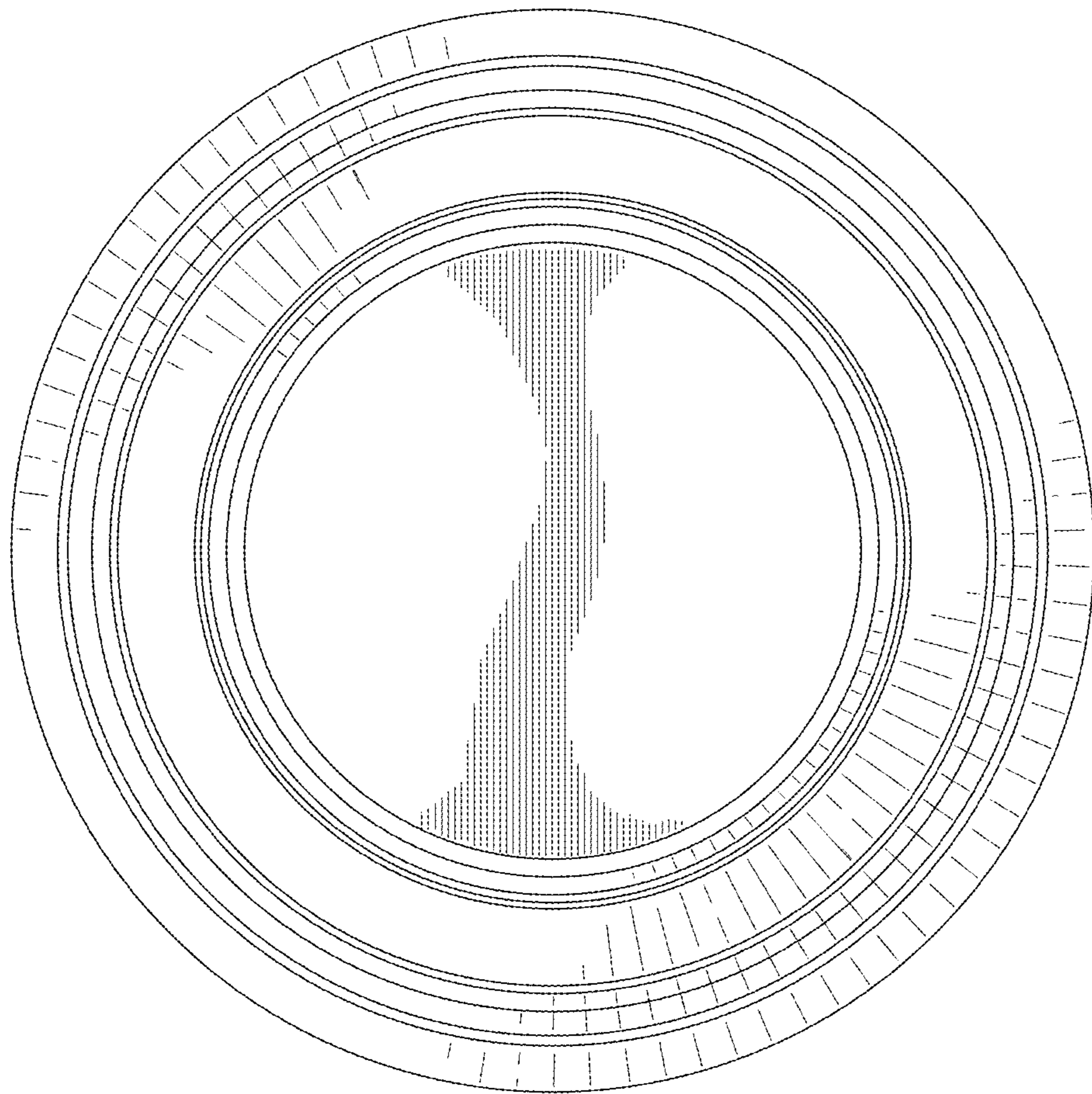

FIG. 14