



US00D786959S

(12) **United States Design Patent**
Lake

(10) **Patent No.:** **US D786,959 S**

(45) **Date of Patent:** **** May 16, 2017**

(54) **PORTABLE PIANO CASE**

(71) Applicant: **J.L. Design, LLC**, Bellevue, WA (US)

(72) Inventor: **Jordan Lake**, Bellevue, WA (US)

(73) Assignee: **J.L. Design, LLC**, Bellevue, WA (US)

(**) Term: **15 Years**

(21) Appl. No.: **29/532,506**

(22) Filed: **Jul. 7, 2015**

(51) **LOC (10) Cl.** **17-01**

(52) **U.S. Cl.**

USPC **D17/9**

(58) **Field of Classification Search**

USPC D3/204; D5/31; D17/1, 2, 4, 5, 7-9, 20,
D17/24, 99; D19/150; D21/409, 586;
84/177, 426, 719, 720, 744, 745

CPC G10F 1/02; G10C 3/12

See application file for complete search history.

(56) **References Cited**

U.S. PATENT DOCUMENTS

549,665 A *	11/1895	Zeidler	G10C 3/02	84/179
D190,201 S *	4/1961	Davis	D17/5	
D224,270 S *	7/1972	Merendino	D17/1	
D229,228 S *	11/1973	Barczak	D17/1	
D238,438 S *	1/1976	Bontempi	D17/5	
D386,514 S *	11/1997	Nakada	D17/7	
D519,544 S *	4/2006	Mikage	D17/9	
D562,877 S *	2/2008	Ikegawa	D17/7	

(Continued)

OTHER PUBLICATIONS

Synthtopia. JL Design Intros Custom Keyboard Stands. Jul. 18, 2015 [earliest online date], [site visited Aug. 31, 2016]. Available from Internet, <URL:http://www.synthtopia.com/content/2015/07/18/jl-design-intros-custom-keyboard-stands/>.*

Primary Examiner — Robert M Spear

Assistant Examiner — Darcey E Heflin

(74) *Attorney, Agent, or Firm* — Hans Santos, PLLC

(57) **CLAIM**

The ornamental design for a portable piano case, as shown and described.

DESCRIPTION

FIG. 1 is a perspective view of a piano performance case taken from the top and front, and showing the portable piano case as it appears with its top cover open, its music stand propped upon the inner surface of the top cover, and its piano drawer pulled outward;

FIG. 2 is a perspective view similar to FIG. 1, but showing the portable piano case as it appears with its top cover open, its music stand folded over the inner surface of the top cover, and its piano drawer pulled outward;

FIG. 3 is a perspective view similar to FIG. 1, but showing the portable piano case as it appears with its top cover open, its music stand left folded over the top cover, and its piano drawer pushed inward;

FIG. 4 is a perspective view similar to FIG. 1, but showing the portable piano case as it appears with its piano drawer and its top cover and music stand closed.

FIG. 5 is a top plan view of the portable piano case of FIG. 4;

FIG. 6 is a bottom plan view of the portable piano case of FIG. 4;

FIG. 7 is a front elevation view of the portable piano case of FIG. 4;

FIG. 8 is a back elevation view of the portable piano case of FIG. 4;

FIG. 9 is a right side elevation view of the portable piano case of FIG. 4; and,

FIG. 10 is a left side elevation view of the portable piano case of FIG. 4.

In the drawings, the broken lines showing portions of the portable piano case depict environment and form no part of the claim.

1 Claim, 8 Drawing Sheets

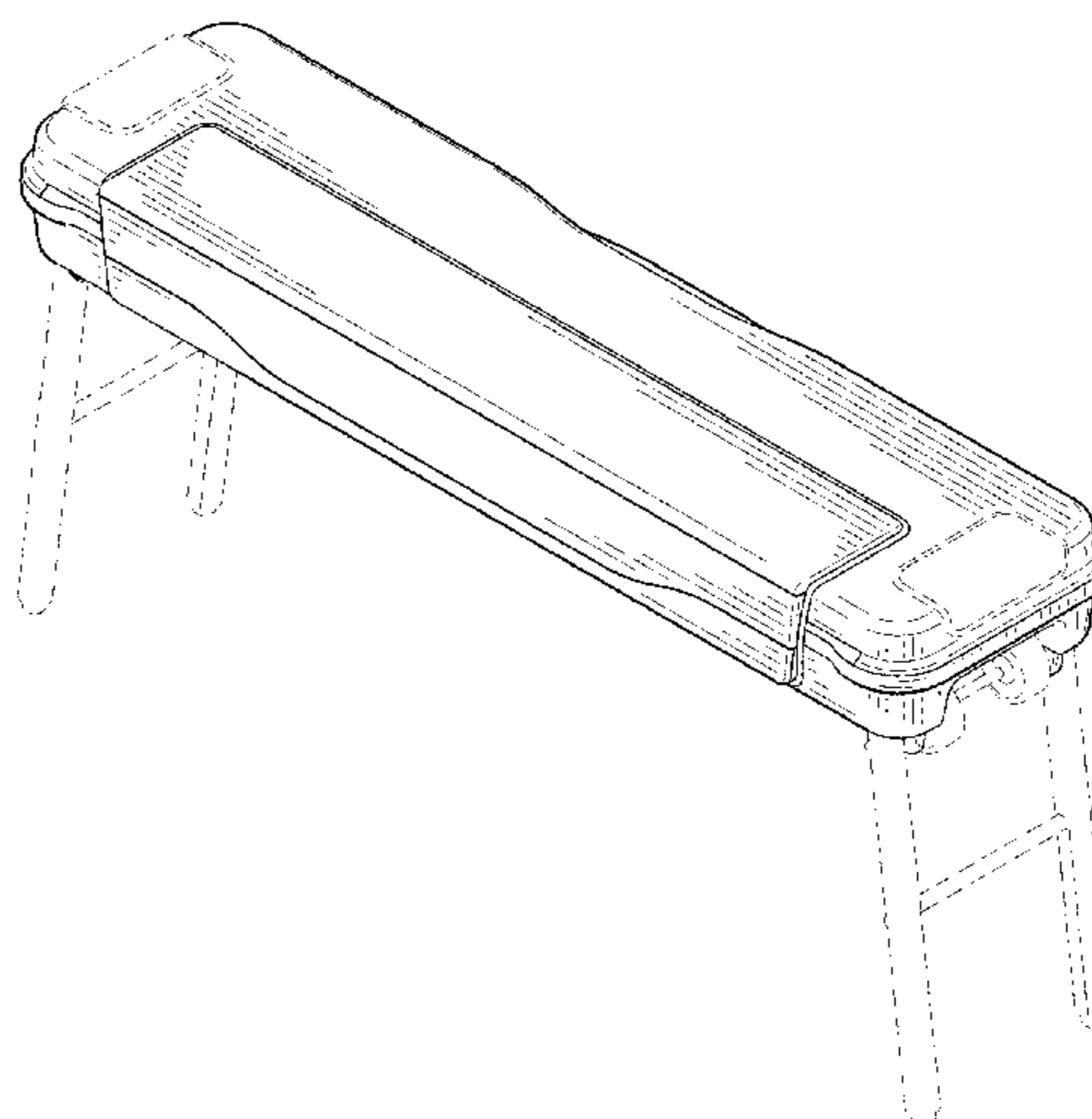
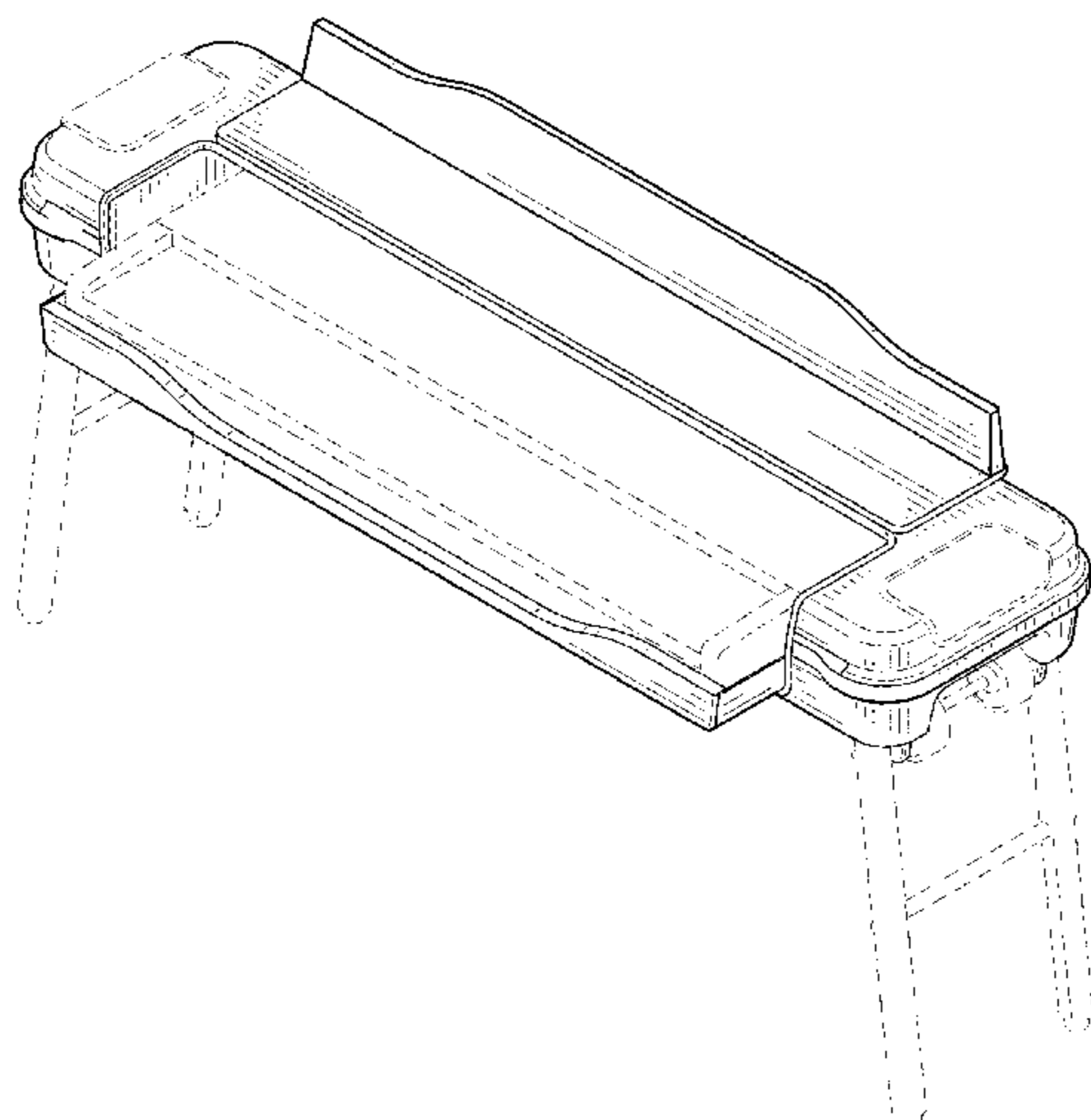

(56)

References Cited

U.S. PATENT DOCUMENTS

D566,162 S *	4/2008	Onishi	D17/1
D610,189 S *	2/2010	Henda	D17/7
D610,190 S *	2/2010	Nimura	D17/7
D673,207 S *	12/2012	Miura	D17/7

* cited by examiner

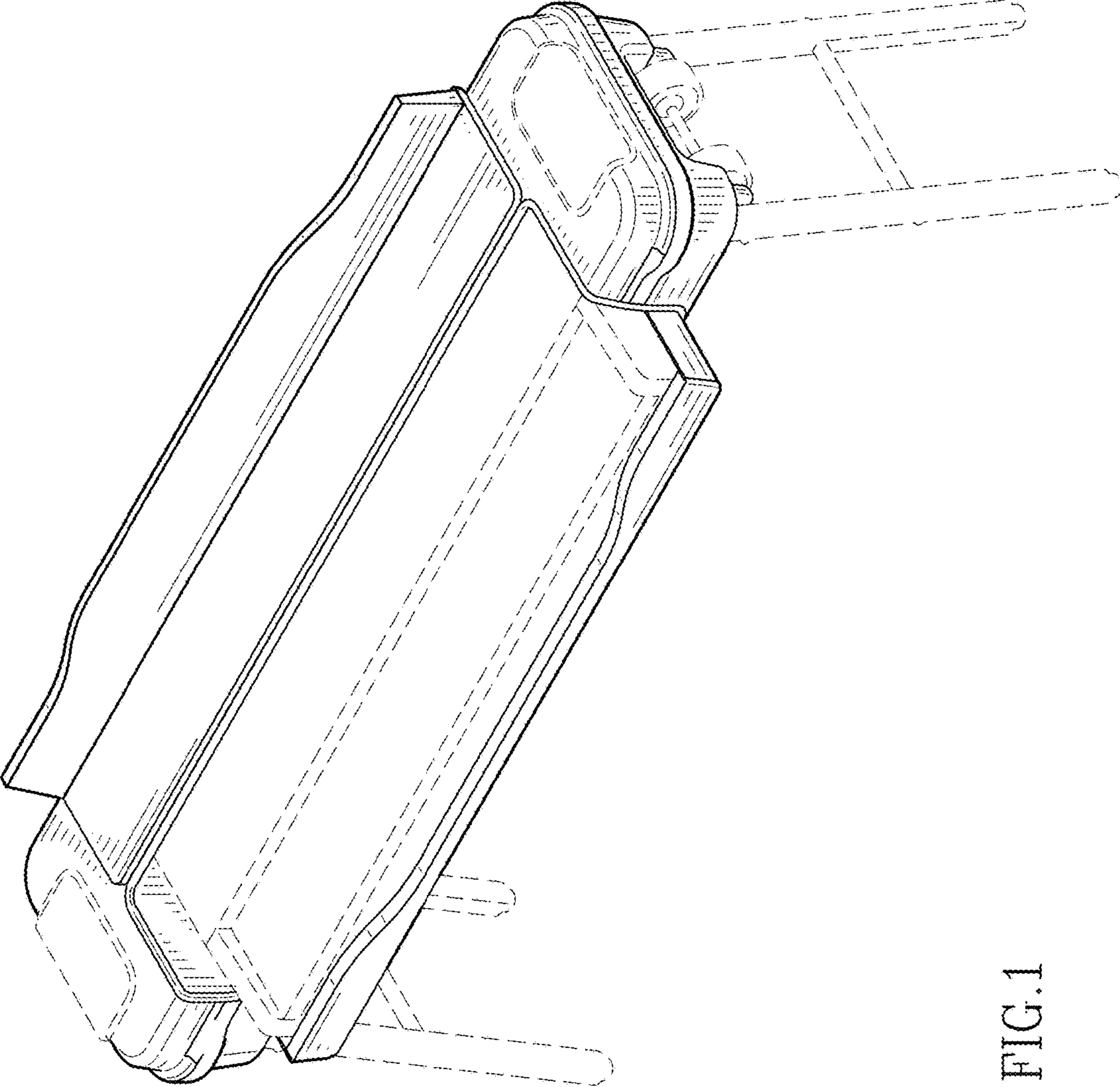

FIG.1

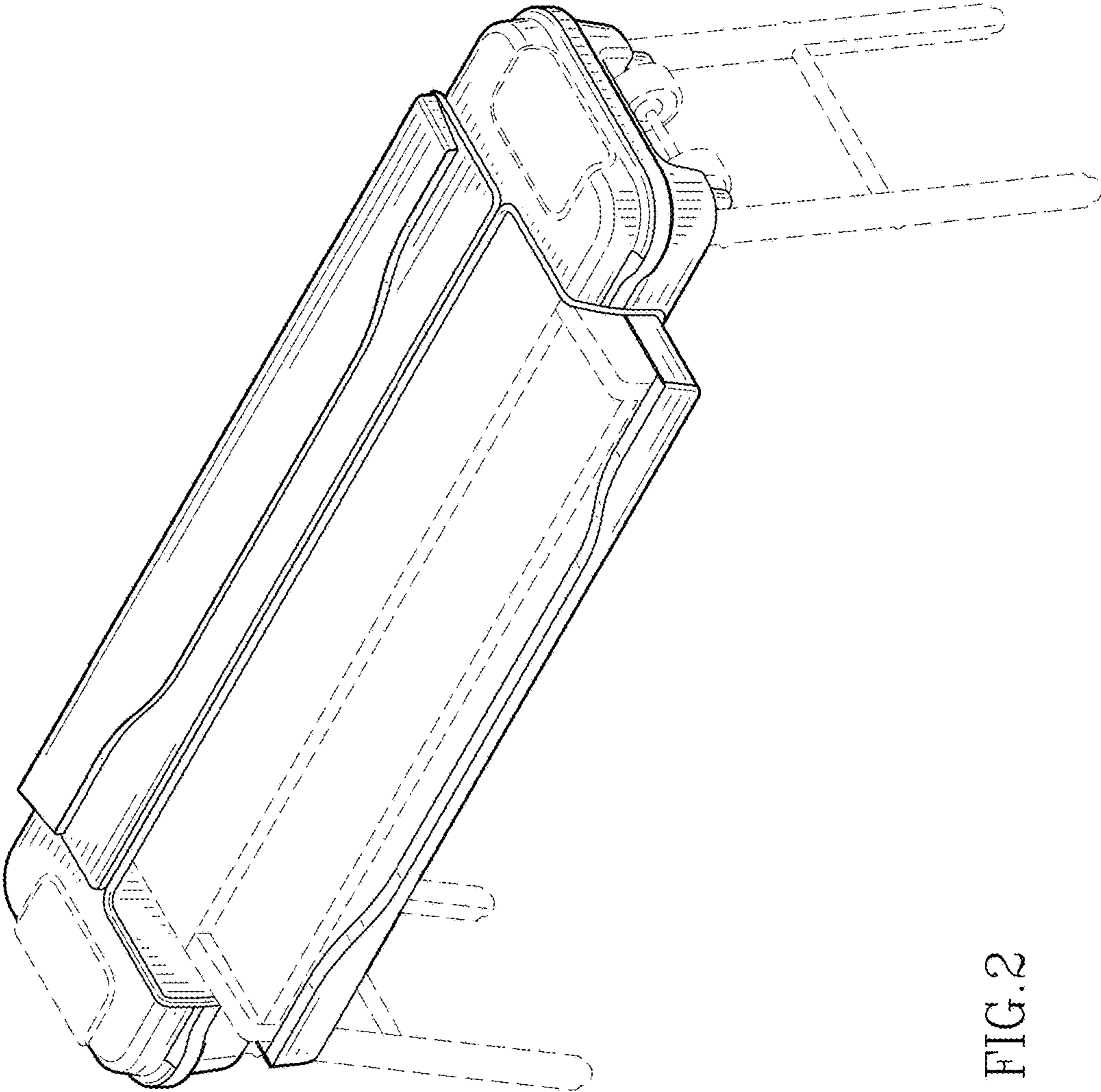

FIG.2

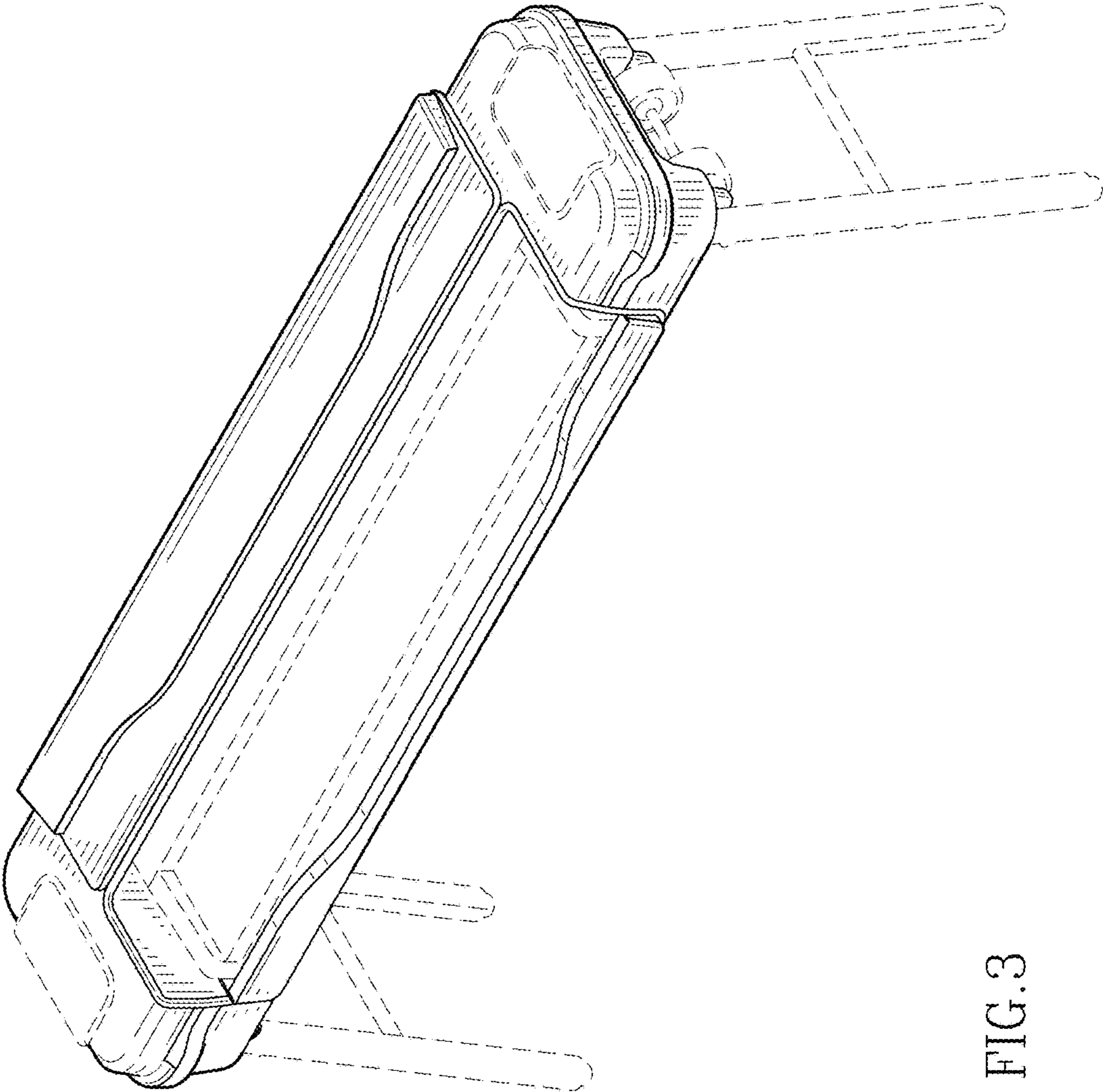

FIG. 3

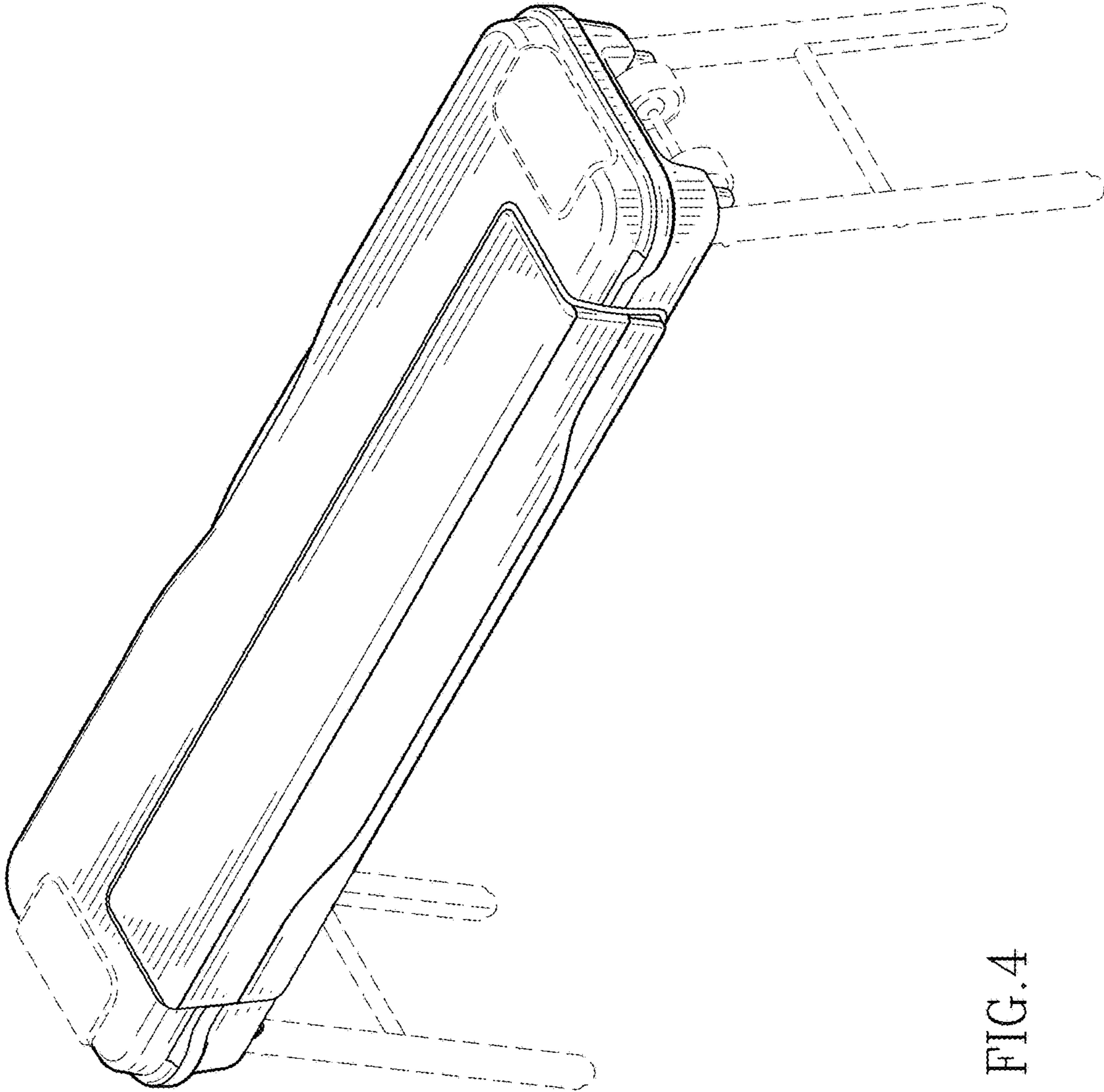

FIG.4

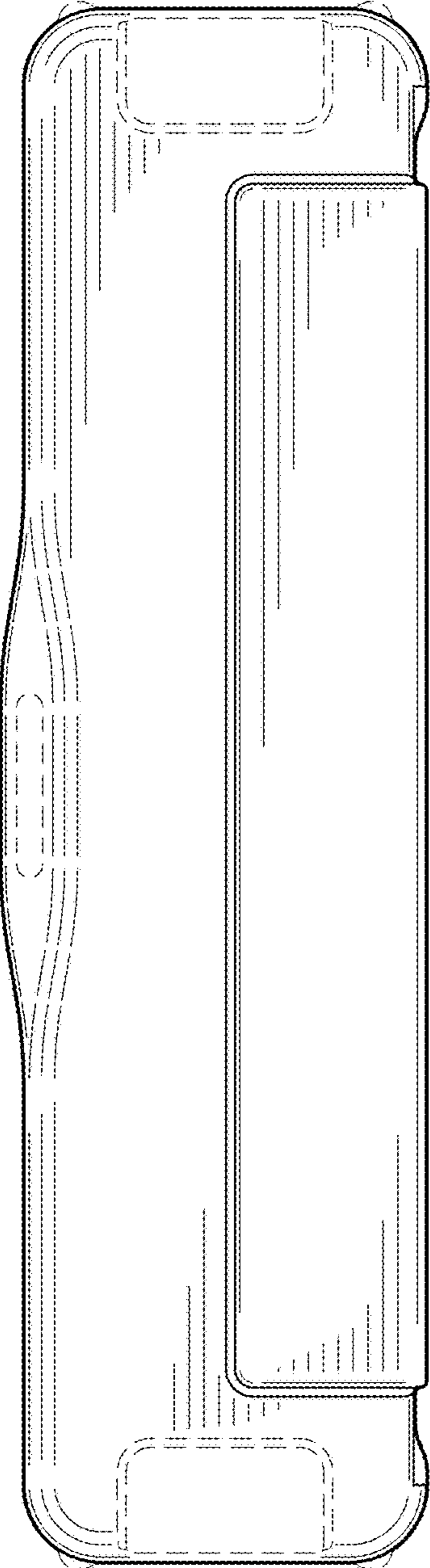

FIG. 5

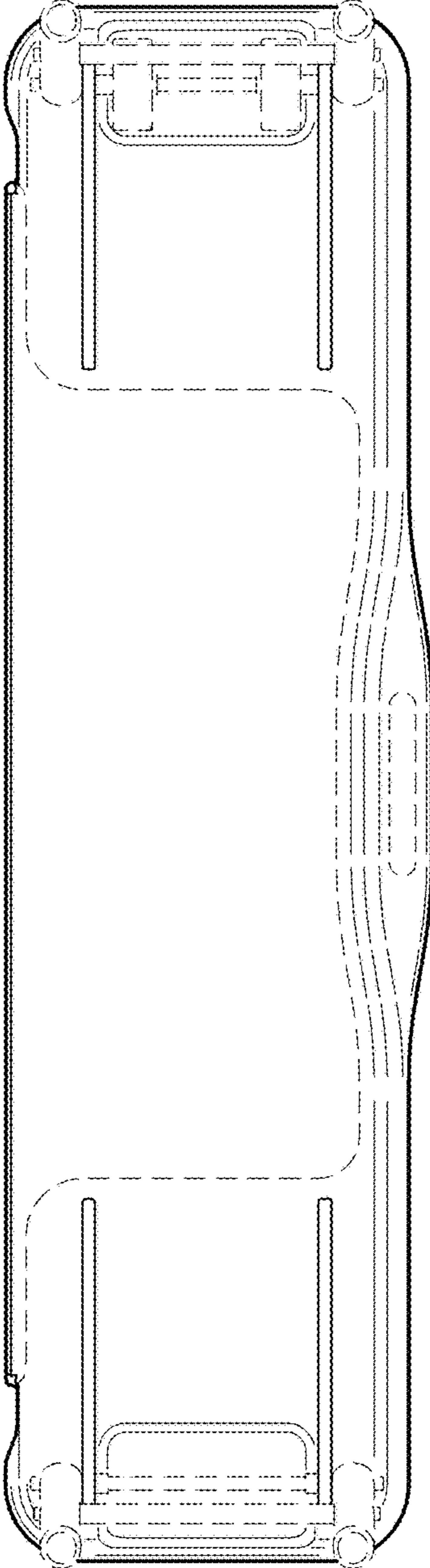

FIG. 6

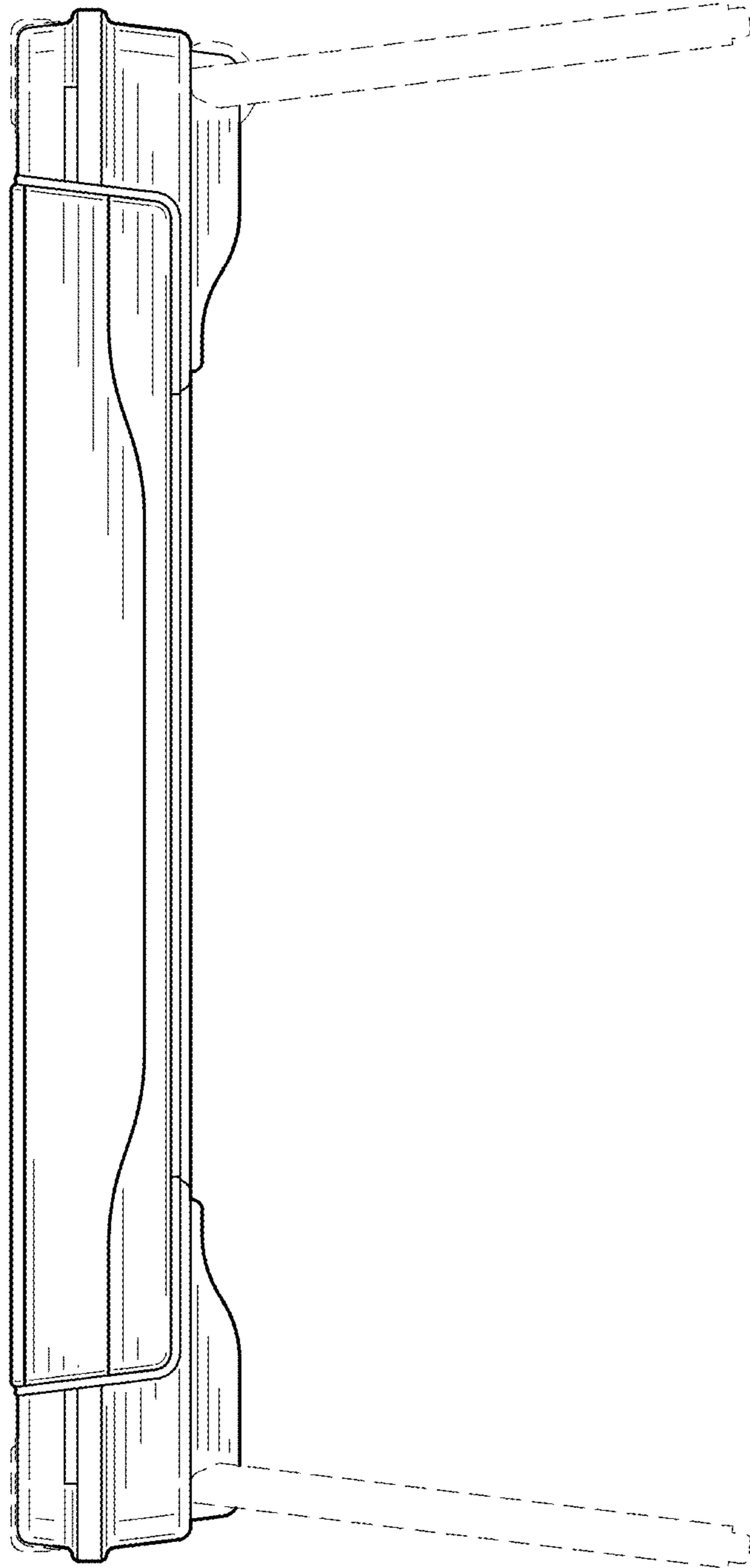

FIG. 7

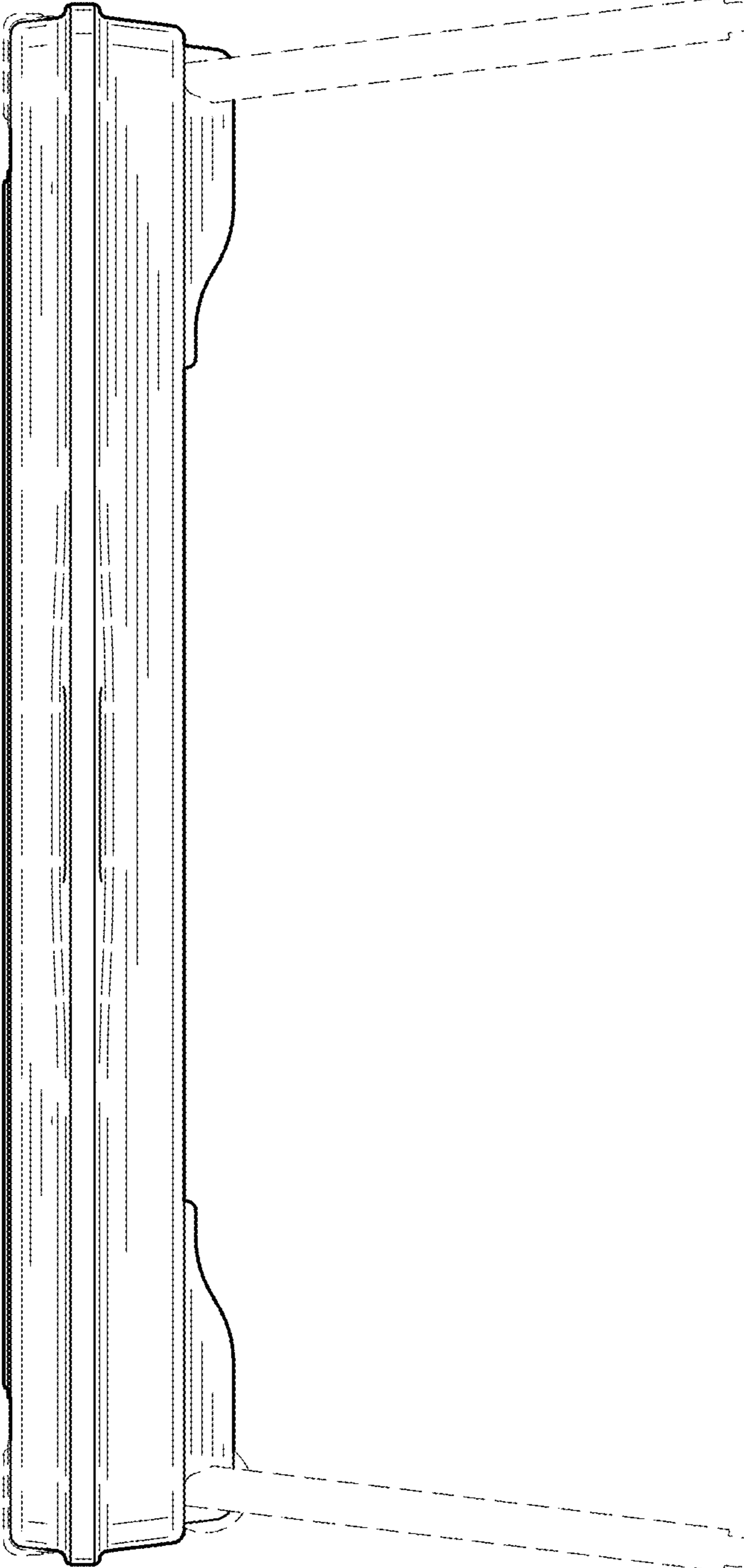

FIG. 8

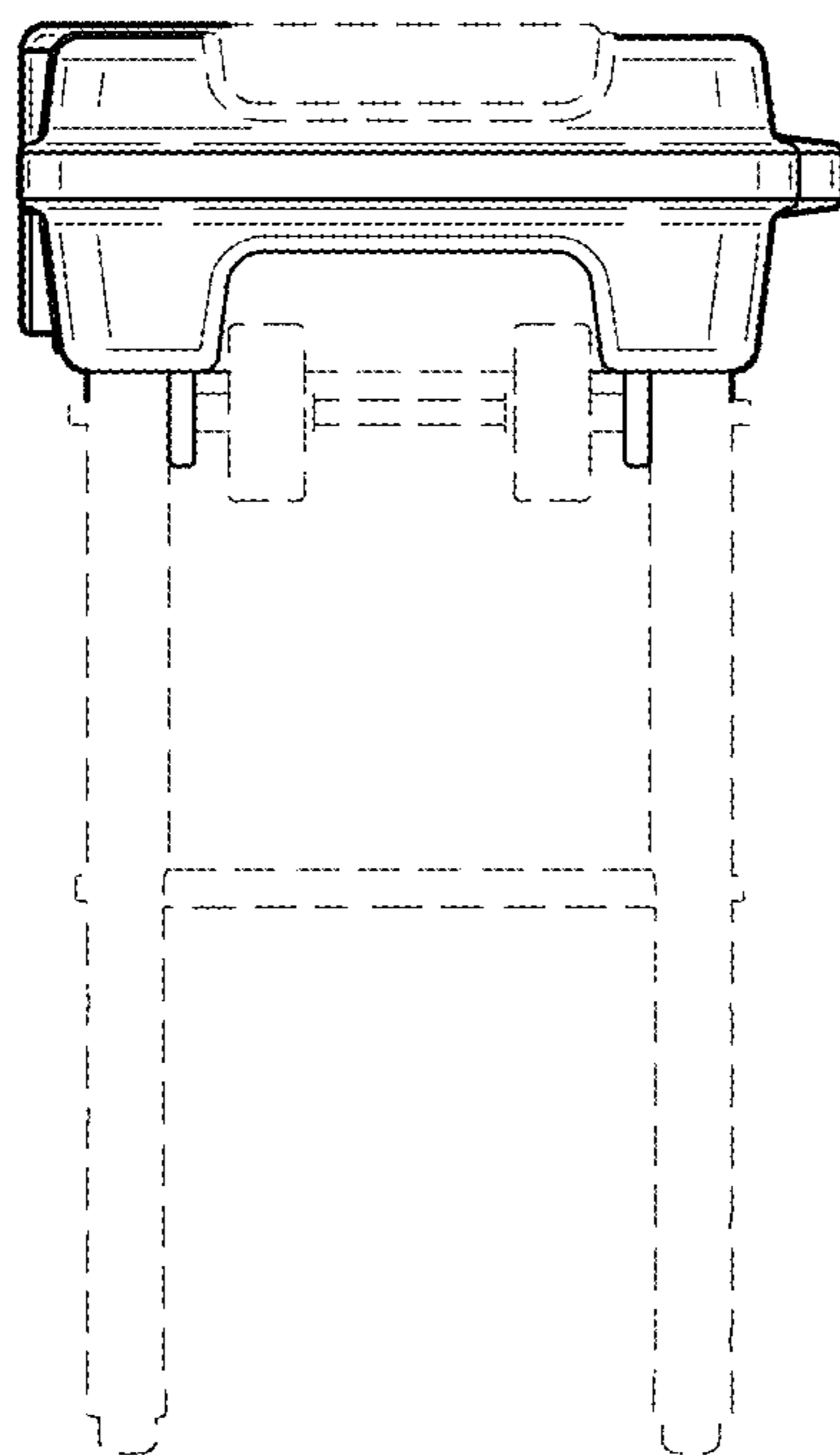

FIG. 9

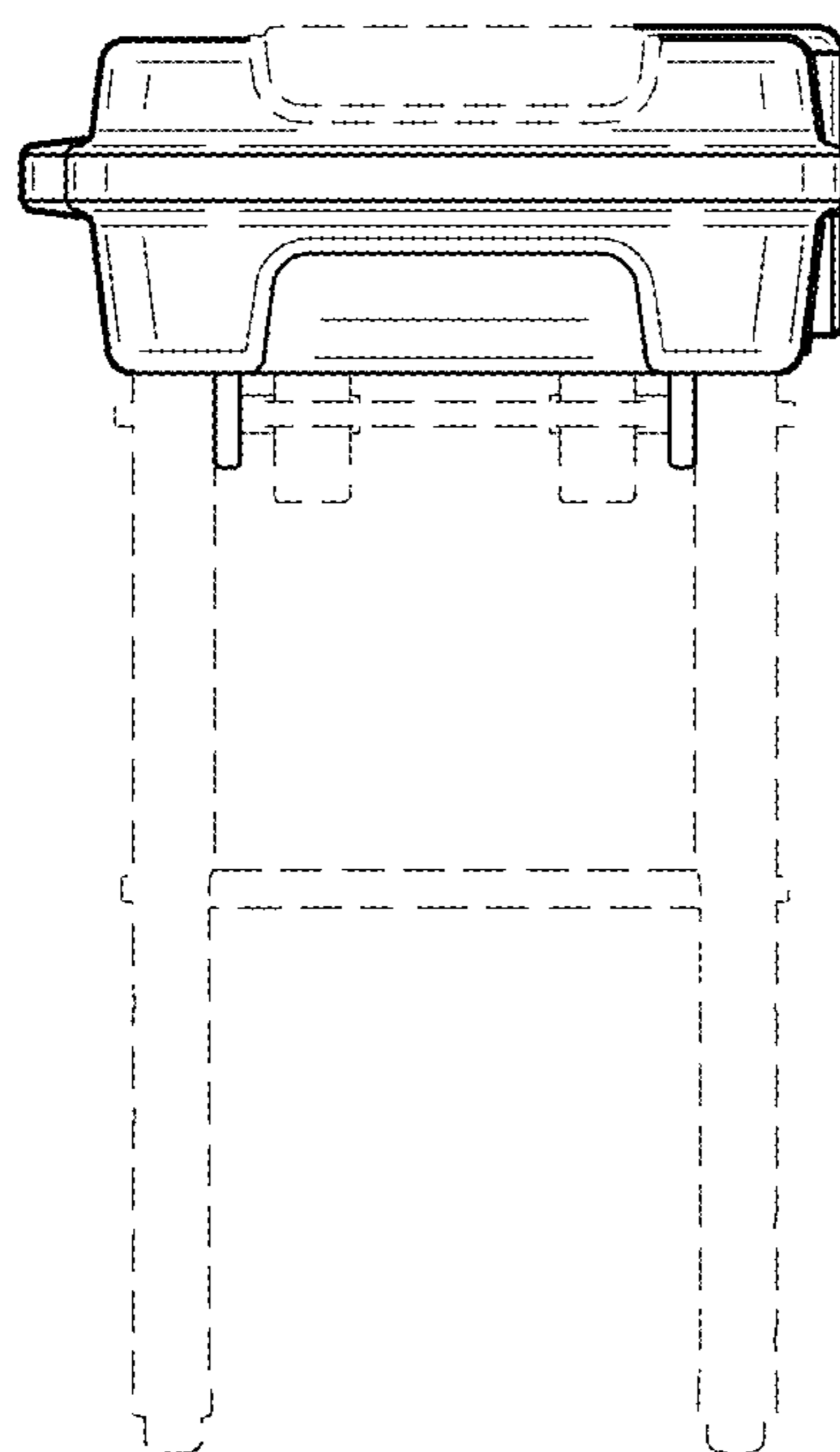

FIG. 10