



US00D786599S

(12) **United States Design Patent**
Ishii et al.

(10) **Patent No.:** **US D786,599 S**

(45) **Date of Patent:** **** May 16, 2017**

(54) **VEHICLE SEAT**

2015/0352986 A1* 12/2015 Fujita B60N 2/68
297/216.1

(71) Applicant: **TACHI-S CO., LTD.**, Tokyo (JP)

* cited by examiner

(72) Inventors: **Atsushi Ishii**, Tokyo (JP); **Shinichi Mizuno**, Tokyo (JP)

Primary Examiner — Rosemary K Tarcza

Assistant Examiner — Christy Nemeth

(73) Assignee: **TACHI-S CO., LTD.**, Tokyo (JP)

(74) *Attorney, Agent, or Firm* — Miles & Stockbridge P.C.

(**) Term: **14 Years**

(57) **CLAIM**

(21) Appl. No.: **29/499,494**

The ornamental design for a vehicle seat, as shown and described.

(22) Filed: **Aug. 15, 2014**

(30) **Foreign Application Priority Data**

DESCRIPTION

Feb. 27, 2014 (JP) 2014-004102

(51) **LOC (10) Cl.** **06-01**

(52) **U.S. Cl.**
USPC **D6/716.4**

(58) **Field of Classification Search**
USPC D6/356, 716, 716.1, 716.4, 611;
180/9.23; 244/122

CPC B60R 2011/0012; B60R 2011/0015; B60N
2/00; B60N 2/24; B60N 2/242; B60N
2/44

See application file for complete search history.

FIG. 1 is a front, top and right side perspective view of a vehicle seat showing our new design;

FIG. 2 is a front elevational view thereof;

FIG. 3 is a rear elevational view thereof;

FIG. 4 is a right side elevational view thereof;

FIG. 5 is a left side elevational view thereof;

FIG. 6 is a top plan view thereof;

FIG. 7 is a bottom plan view thereof;

FIG. 8 is an enlarged fragment view taken along line 8-8 in FIG. 2 thereof; and,

FIG. 9 is a cross-sectional view taken along line 9-9 in FIG. 8.

The dash-dot-dash broken lines represent the boundary lines of the claimed design.

The lightweight dashed broken lines shown in the drawings outside of the dash-dot-dash boundary lines represent portions of the vehicle seat that form no part of the claimed design.

The heavyweight dashed broken lines shown in the drawings within the dash-dot-dash boundary lines illustrate stitching and do form a part of the claimed design.

(56) **References Cited**

U.S. PATENT DOCUMENTS

- | | | | | |
|-------------------|---------|-----------|-------|---------------------------|
| D356,694 S * | 3/1995 | Armbrecht | | D6/334 |
| D534,005 S * | 12/2006 | Beermann | | D6/356 |
| D572,050 S * | 7/2008 | Tamara | | D6/366 |
| D726,470 S * | 4/2015 | Itou | | D6/716.4 |
| 2010/0187876 A1 * | 7/2010 | Nitsuma | | B60N 2/4228
297/216.13 |
| 2013/0057035 A1 * | 3/2013 | Nishiura | | B60N 2/7011
297/218.3 |

1 Claim, 9 Drawing Sheets

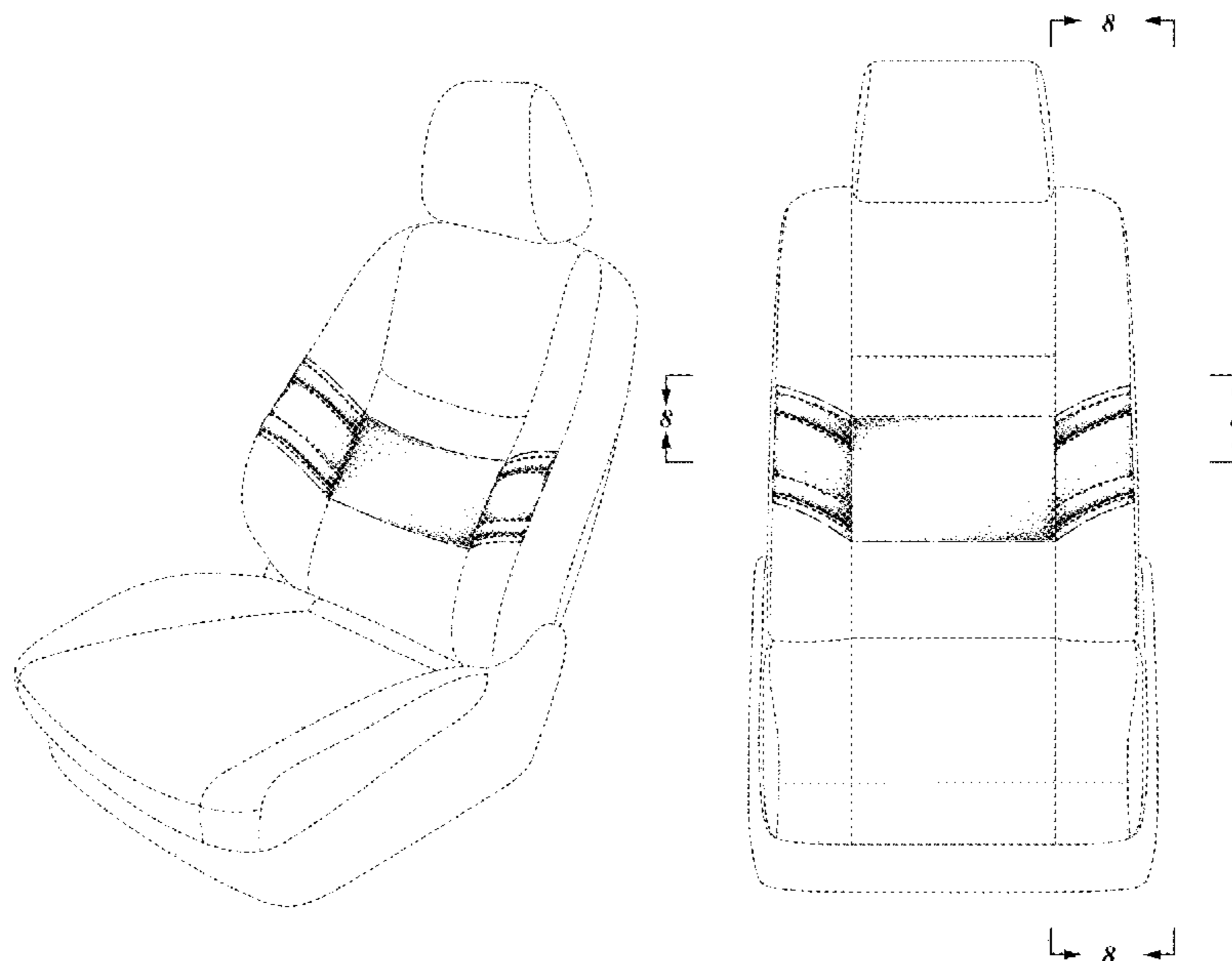

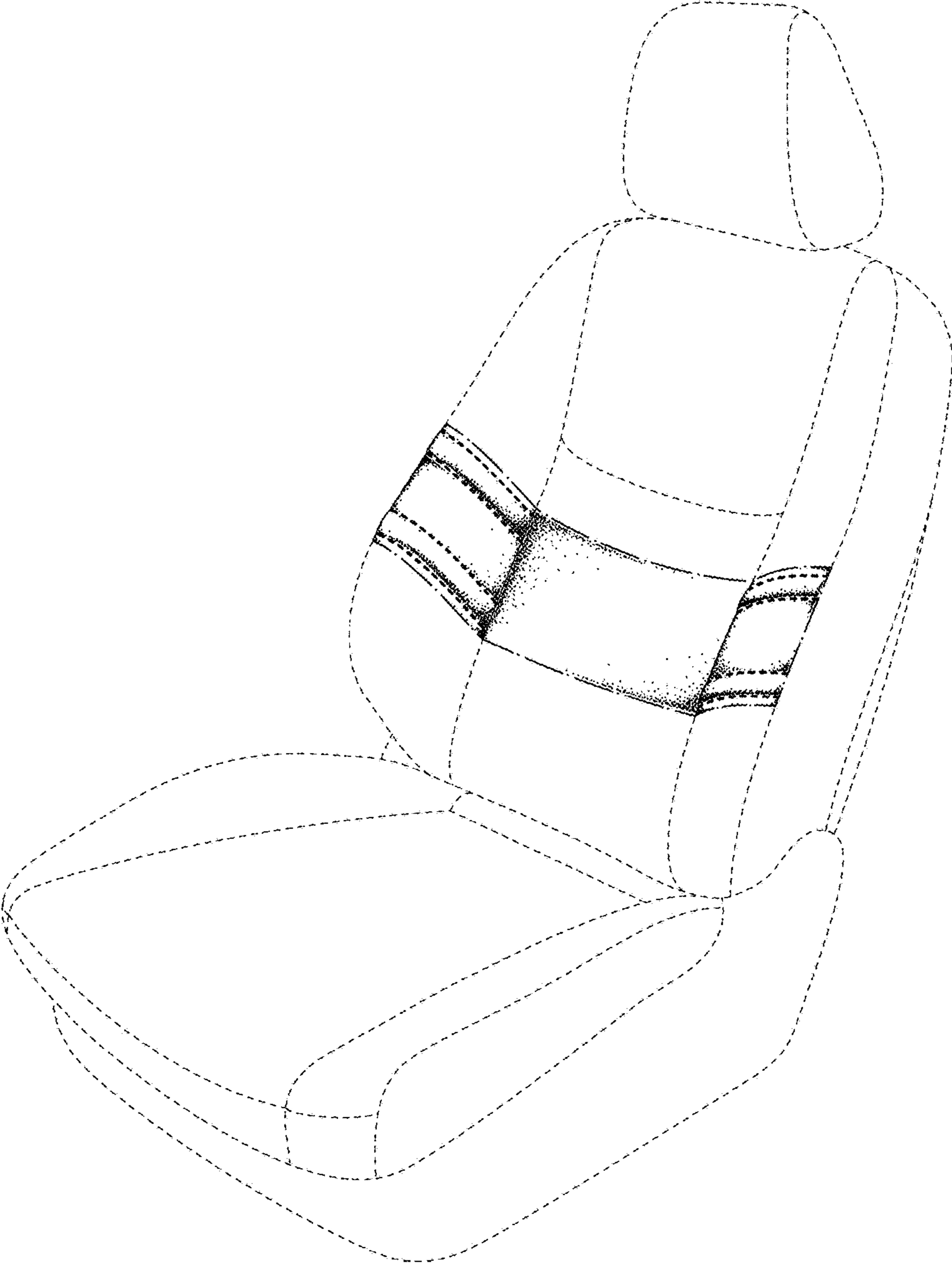

Fig. 1

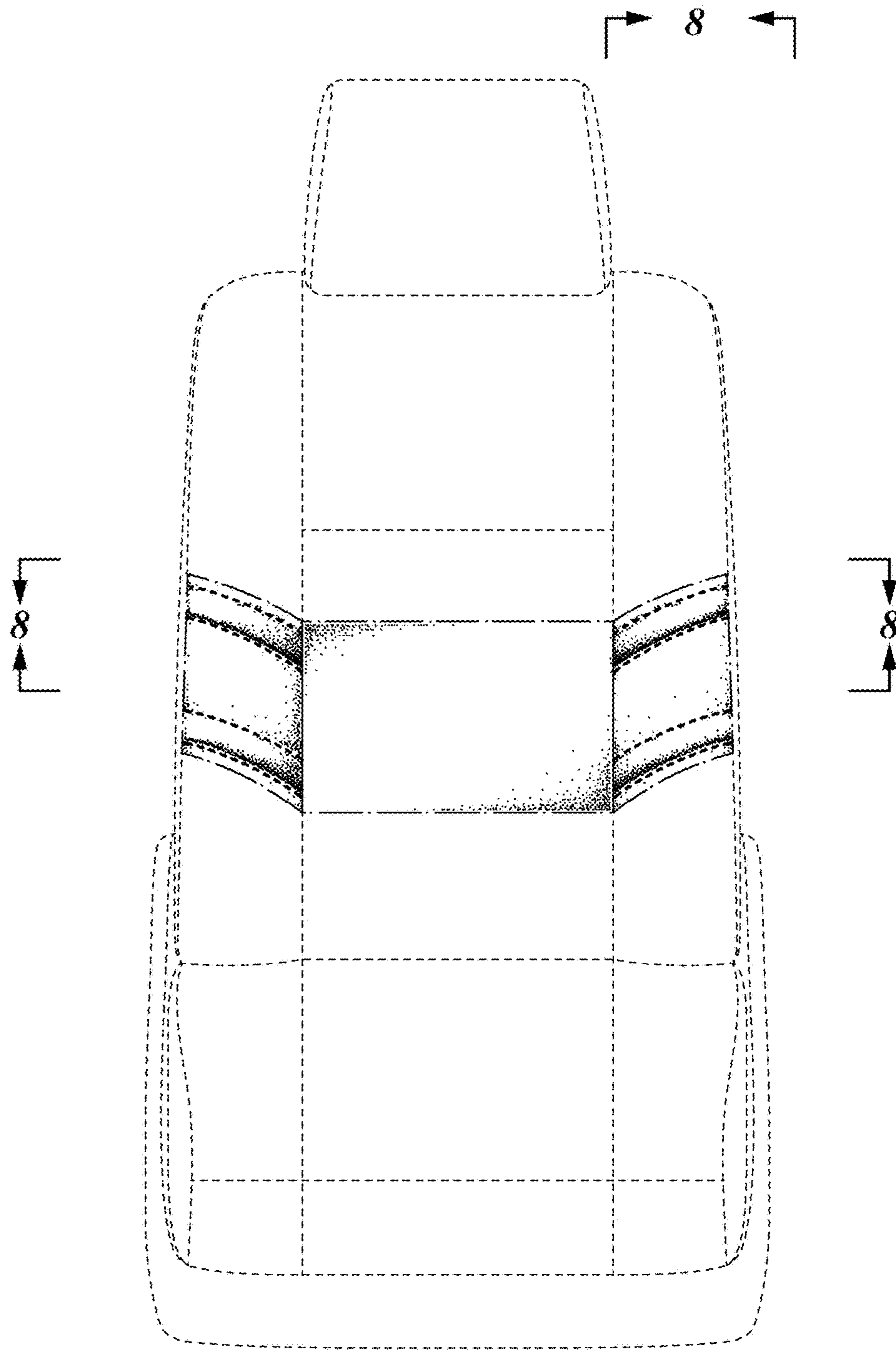
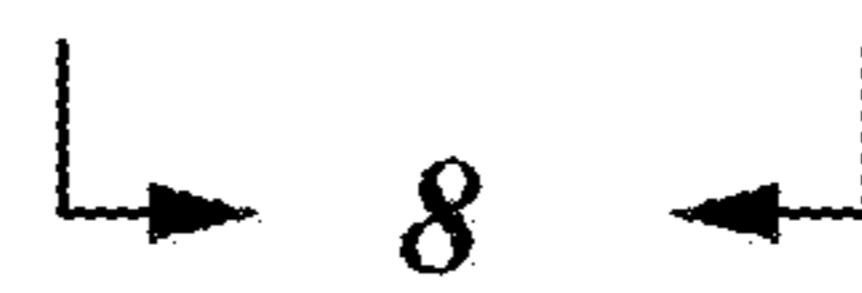

Fig. 2



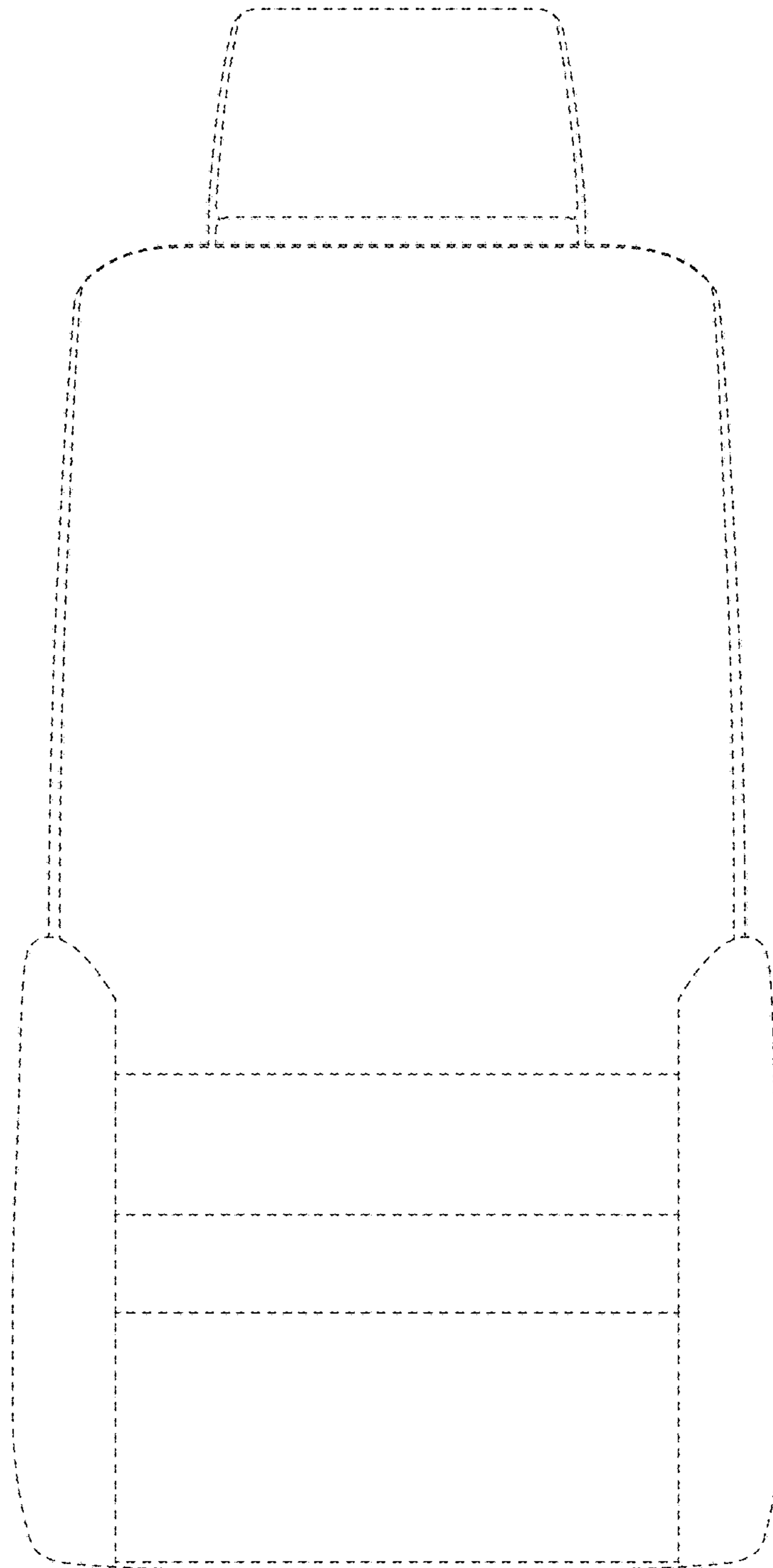

Fig. 3

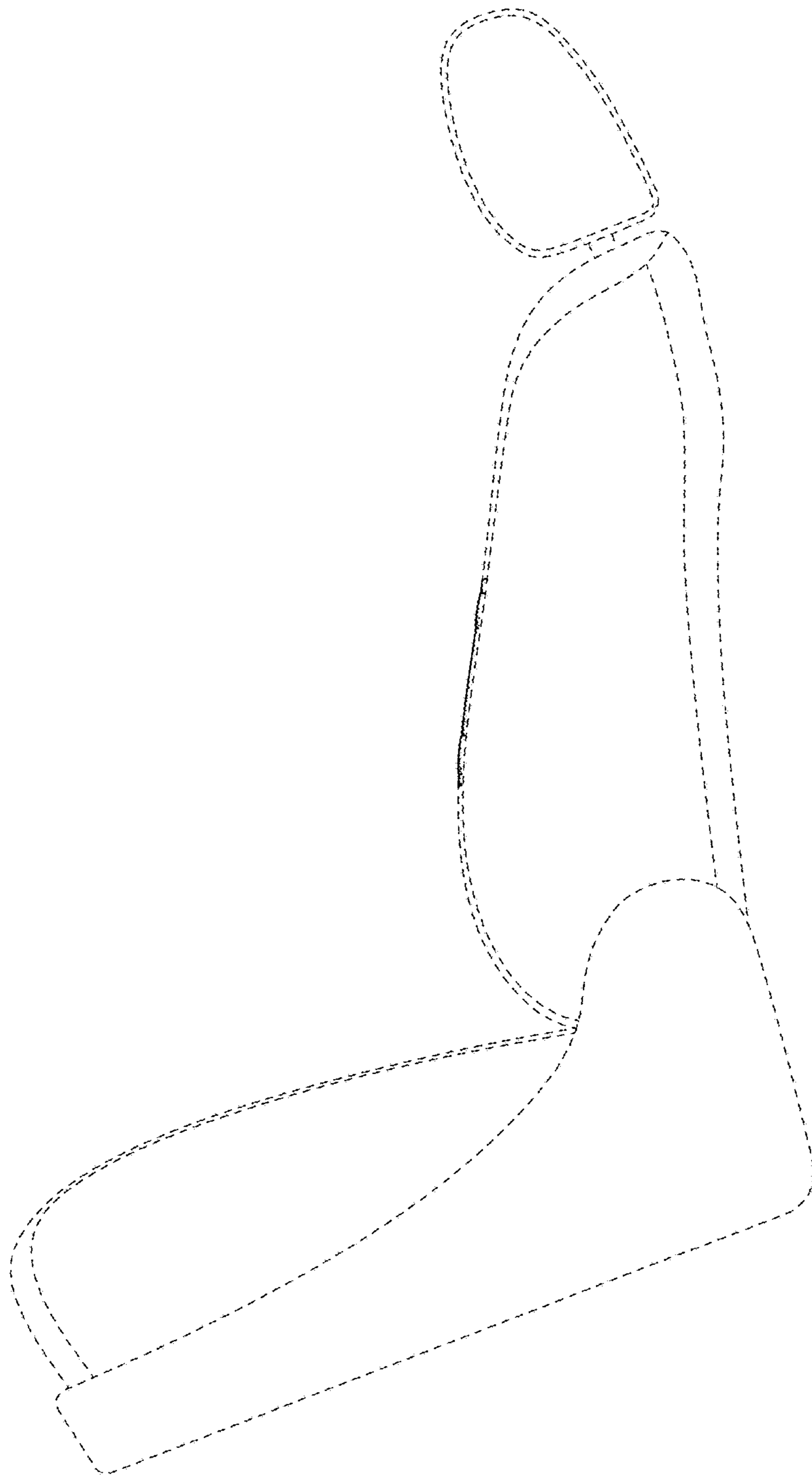

Fig. 4

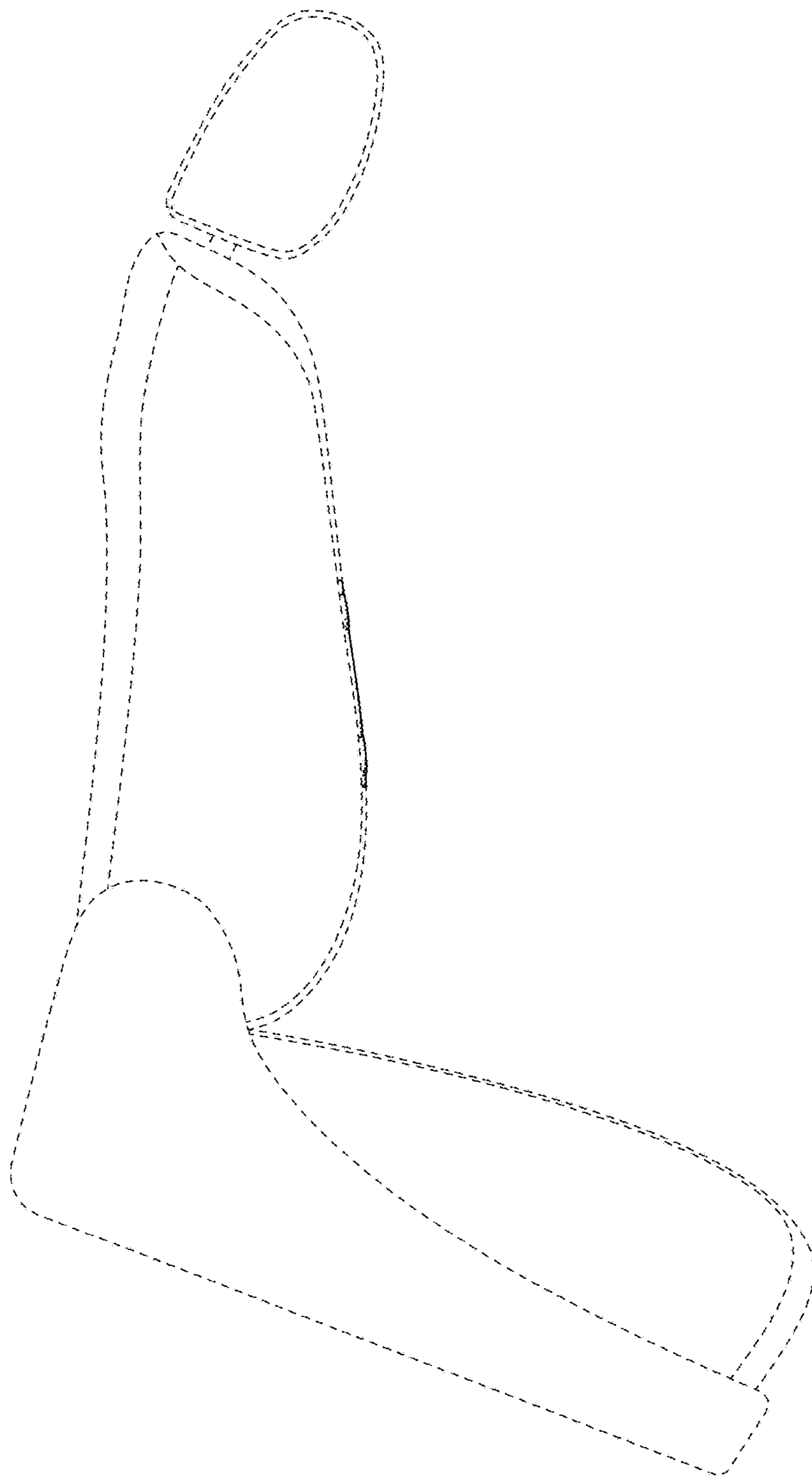

Fig. 5

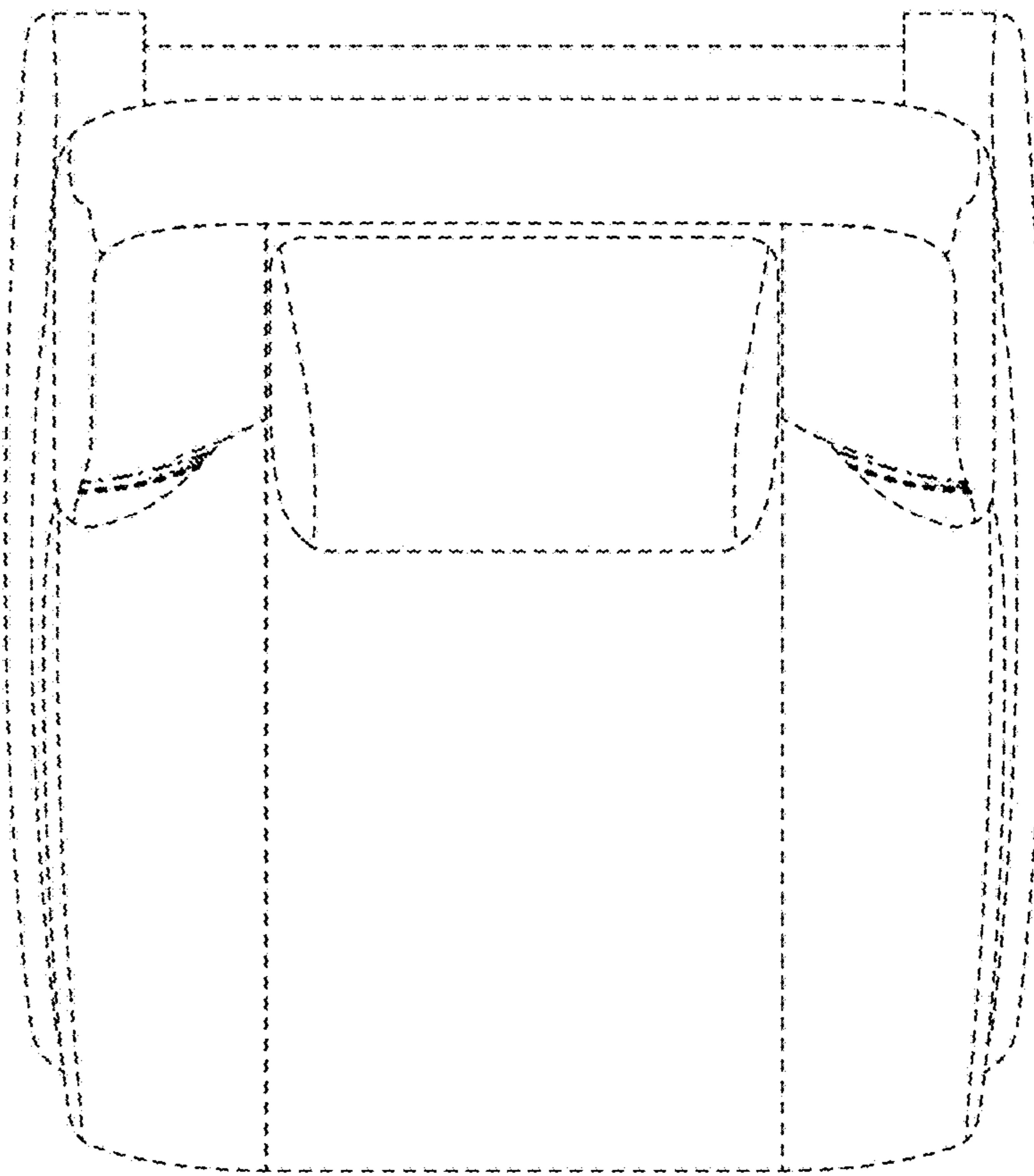

Fig. 6

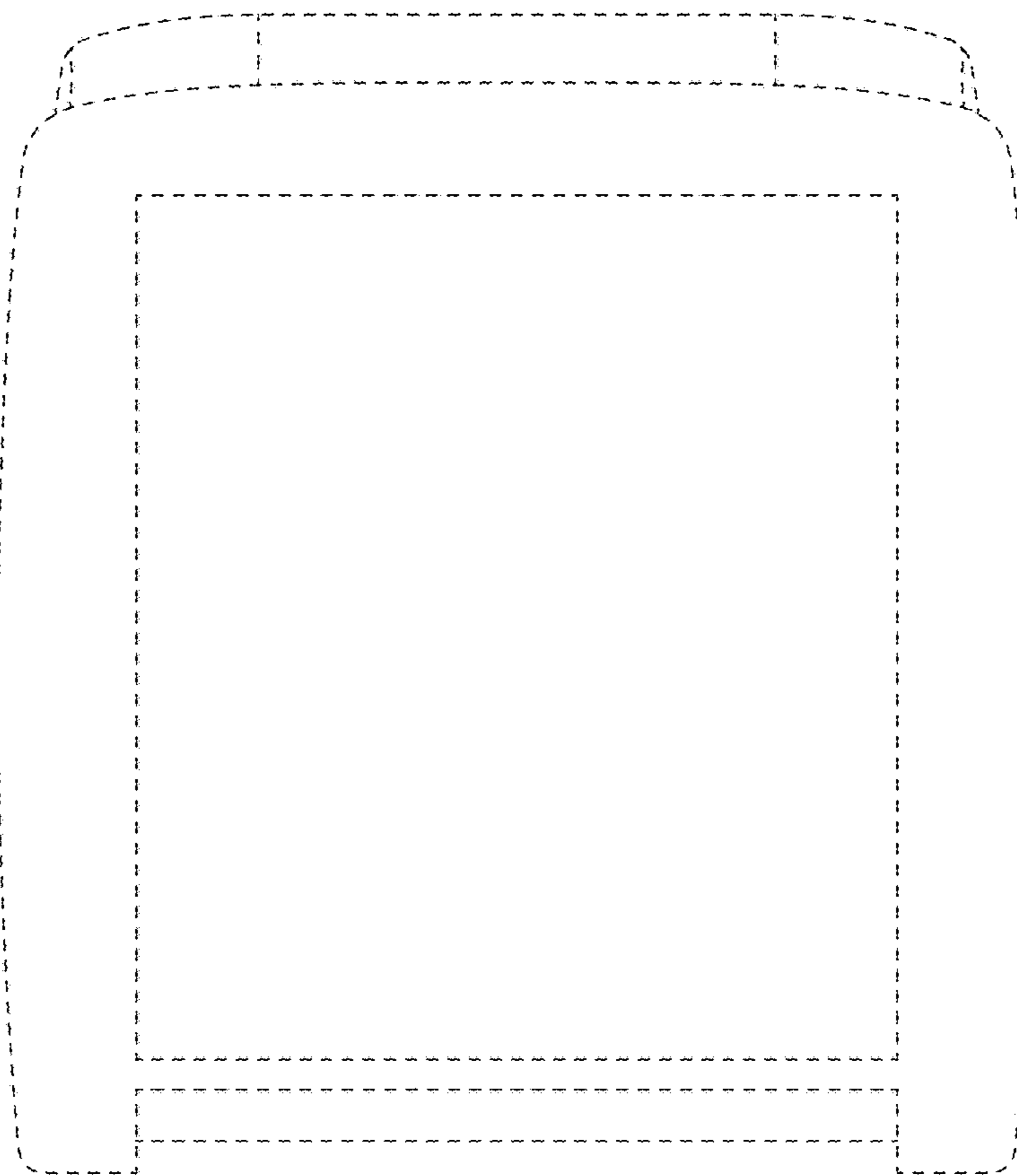

Fig. 7

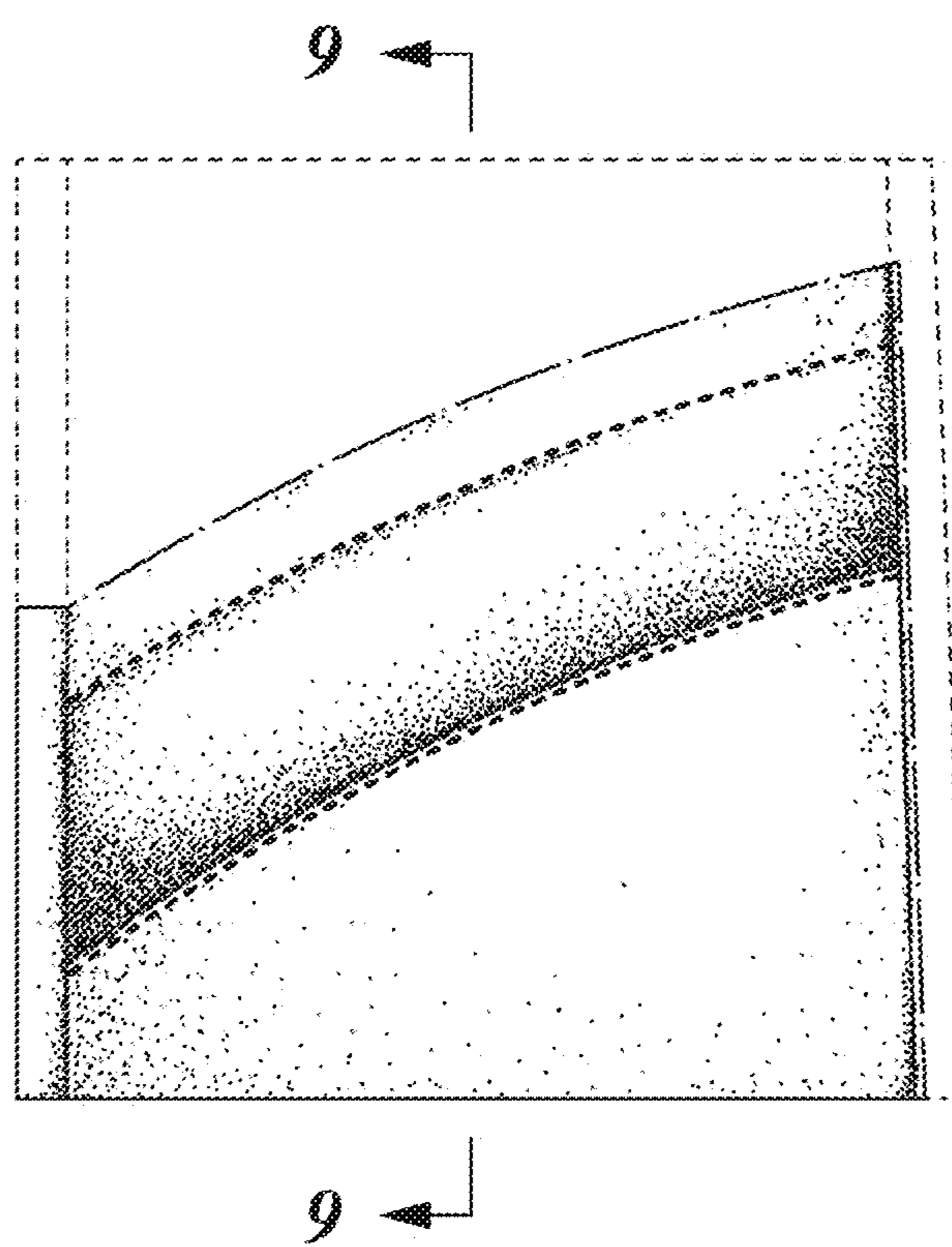

Fig. 8

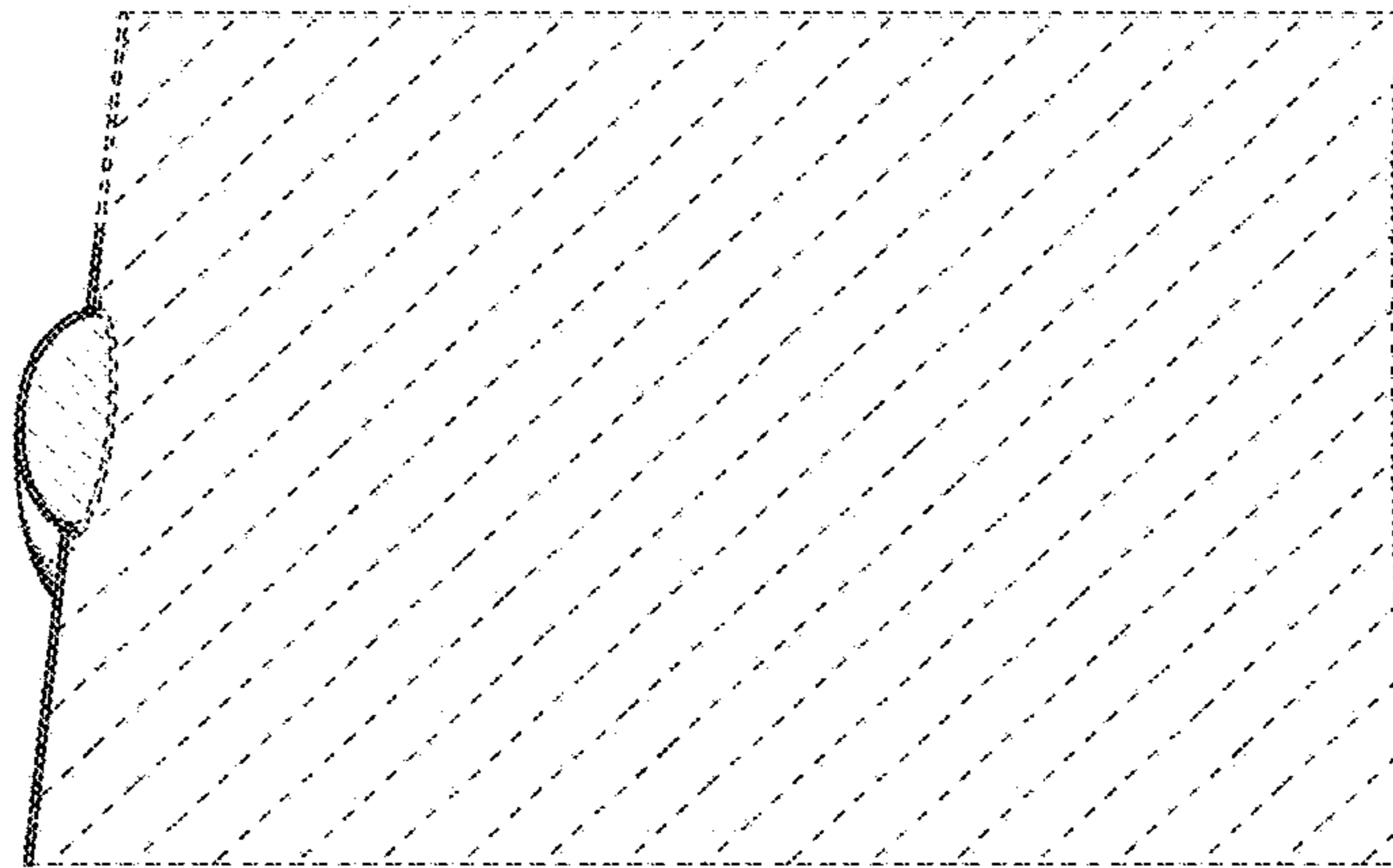

Fig. 9