



US00D785831S

(12) **United States Design Patent**
Park et al.

(10) **Patent No.:** **US D785,831 S**

(45) **Date of Patent:** **** May 2, 2017**

(54) **REAR COMBINATION LAMP FOR AN
AUTOMOBILE**

(71) Applicant: **Hyundai Motor Company**, Seoul (KR)

(72) Inventors: **Dong-Jin Park**, Seoul (KR); **Dai-Sung
Kim**, Gyeonggi-do (KR)

(73) Assignee: **Hyundai Motor Company**, Seoul (KR)

(**) Term: **15 Years**

(21) Appl. No.: **29/555,943**

(22) Filed: **Feb. 25, 2016**

(30) **Foreign Application Priority Data**

Oct. 30, 2015 (KR) 30-2015-0054633

(51) **LOC (10) Cl.** **26-06**

(52) **U.S. Cl.**
USPC **D26/28**

(58) **Field of Classification Search**
USPC D26/28–36; 362/80–83, 267–269,
362/459–468, 475–478, 485–487
CPC F21S 48/00; F21S 48/10; F21S 48/115;
F21S 48/225; F21S 48/1233; F21S
48/1266; F21S 48/1388; F21S 48/2268;
F21V 21/04
See application file for complete search history.

(56) **References Cited**

U.S. PATENT DOCUMENTS

D657,482 S * 4/2012 Kong D26/28
D675,353 S * 1/2013 Kazama D26/28

D710,523 S * 8/2014 Kaneda D26/28
D739,583 S * 9/2015 Forsgren D26/28
D755,422 S * 5/2016 Kong D26/28
D760,409 S * 6/2016 Arroba D26/28

* cited by examiner

Primary Examiner — Marcus Jackson

(74) *Attorney, Agent, or Firm* — Mintz Levin Cohn Ferris
Glovsky and Popeo, P.C.; Kongsik Kim

(57) **CLAIM**

The ornamental design for a rear combination lamp for an
automobile, as shown and described.

DESCRIPTION

FIG. 1 is a perspective view of a rear combination lamp for
an automobile according to the present invention.

FIG. 2 is a front view of the rear combination lamp for an
automobile of FIG. 1.

FIG. 3 is a rear view of the rear combination lamp for an
automobile of FIG. 1.

FIG. 4 is a left side view of the rear combination lamp for
an automobile of FIG. 1.

FIG. 5 is a right side view of the rear combination lamp for
an automobile of FIG. 1.

FIG. 6 is a top view of the rear combination lamp for an
automobile of FIG. 1; and,

FIG. 7 is a bottom view of the rear combination lamp for an
automobile of FIG. 1.

1 Claim, 7 Drawing Sheets

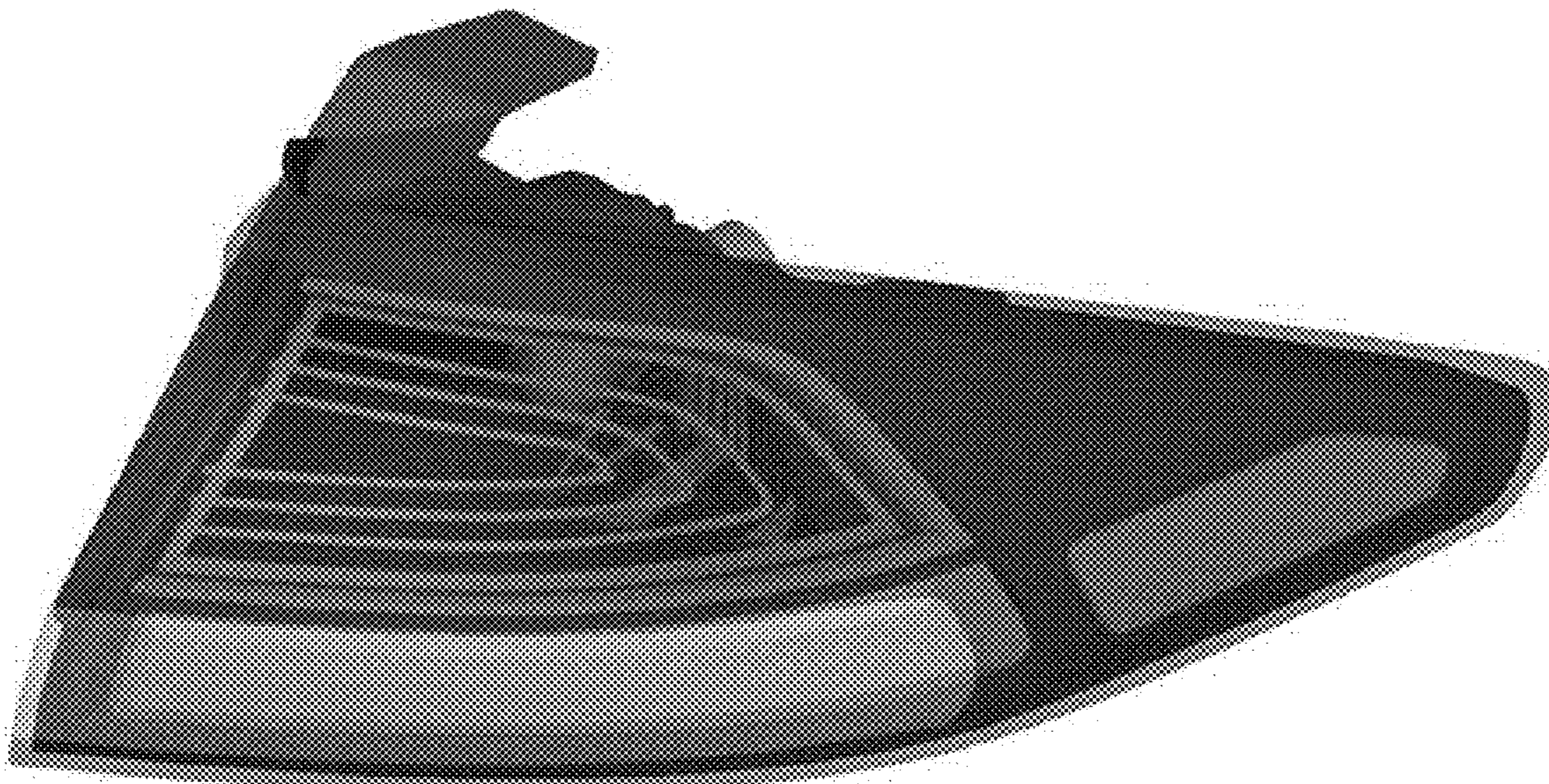

FIG. 1

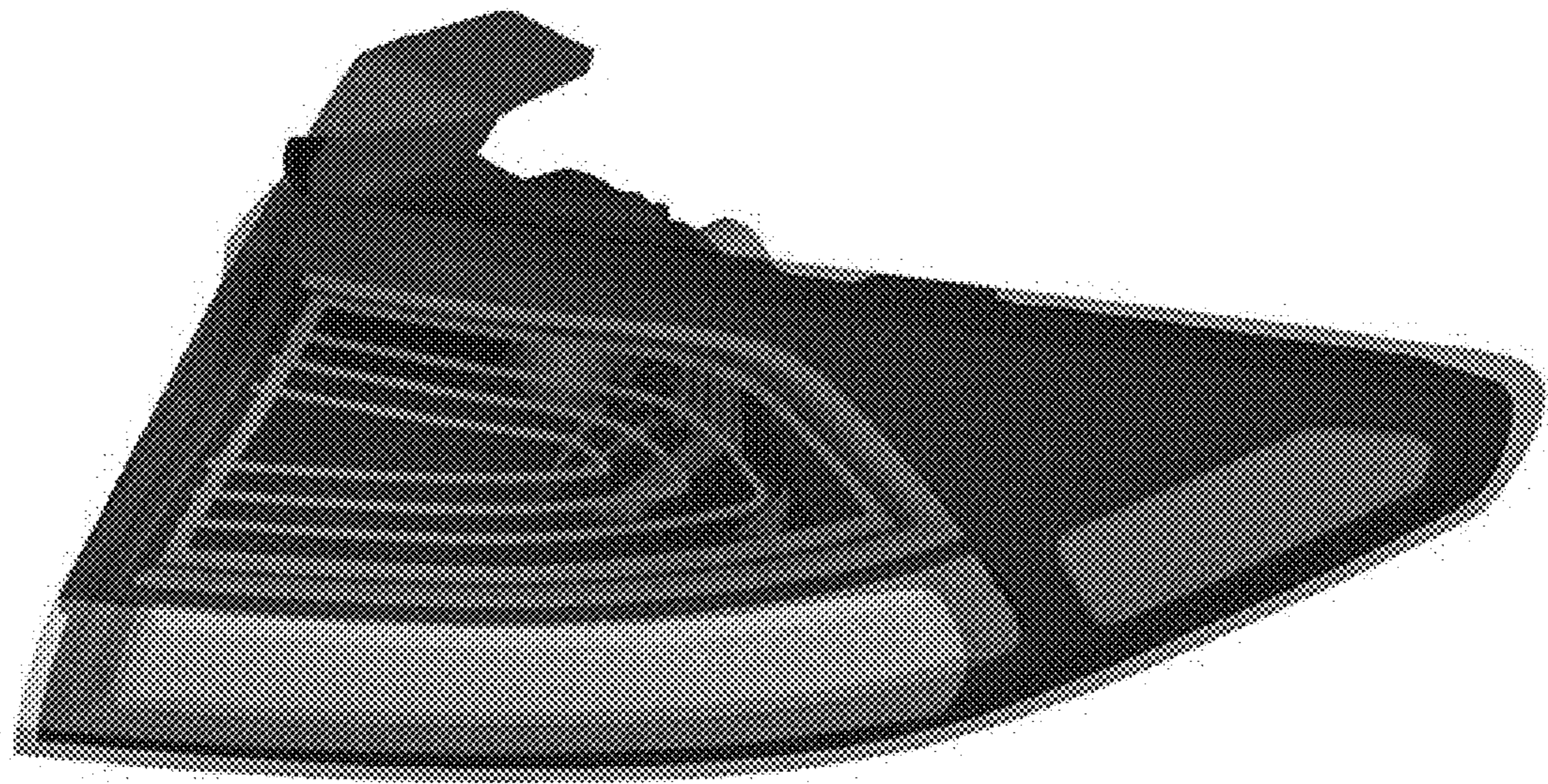

FIG. 2

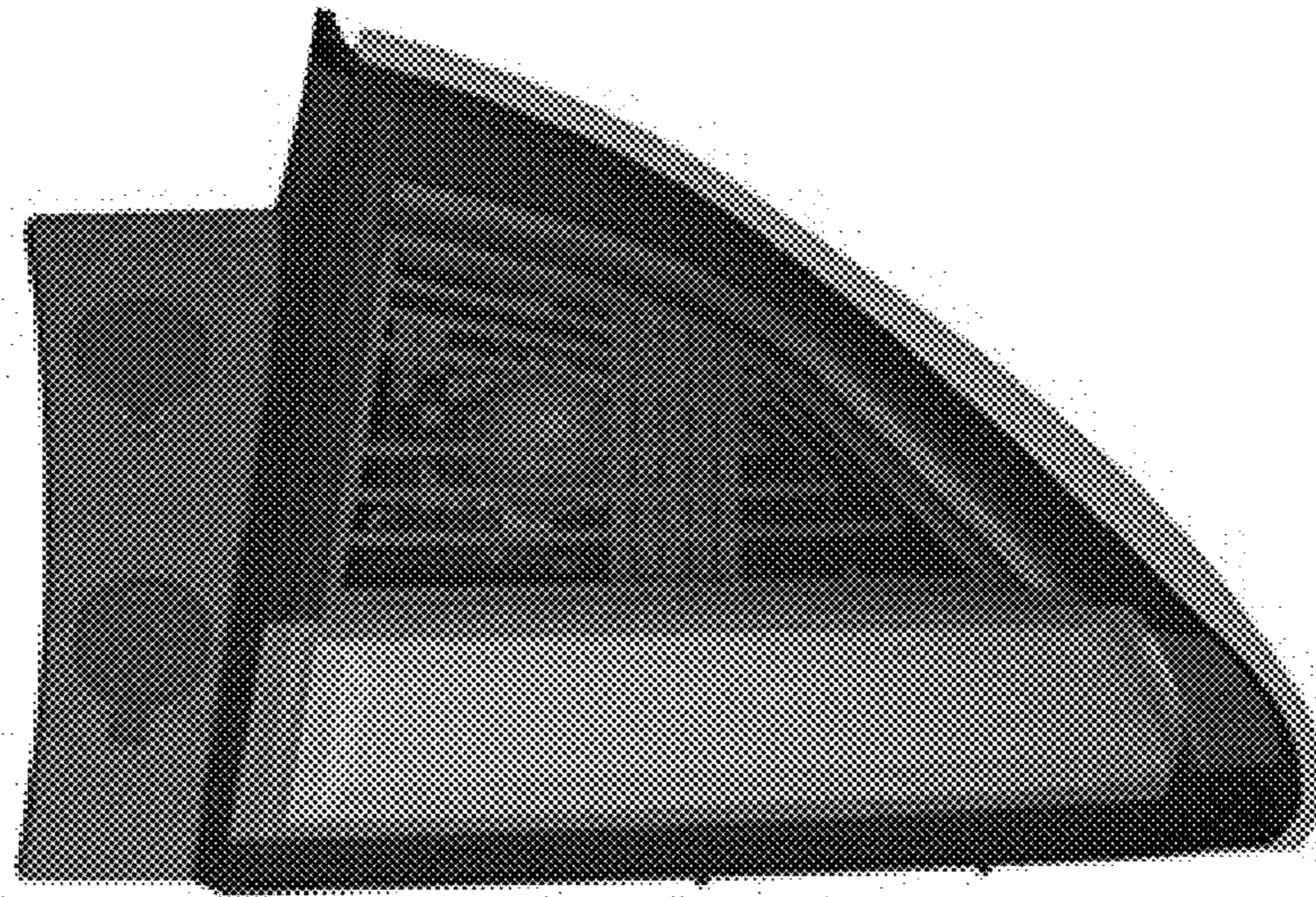

FIG. 3

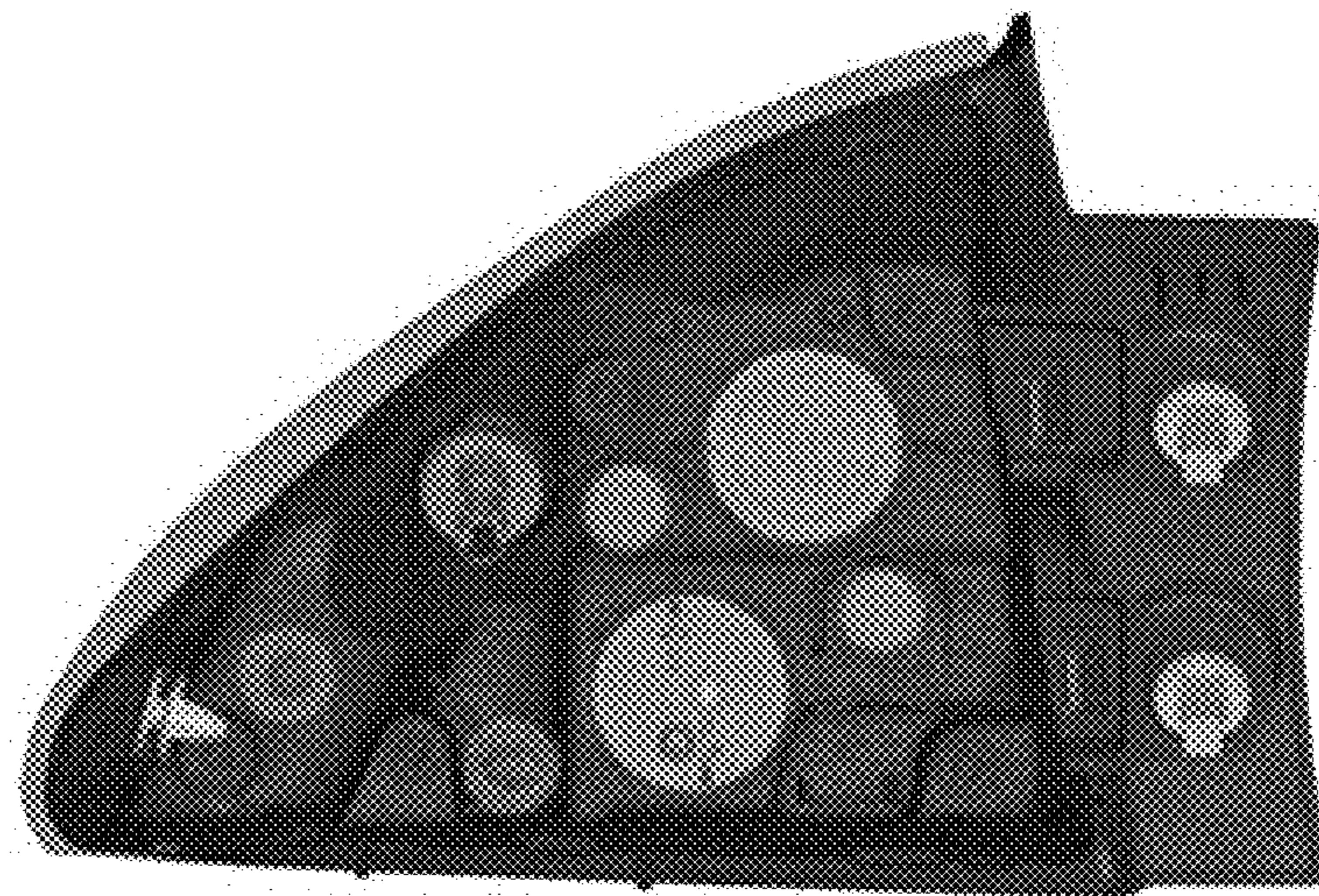

FIG. 4

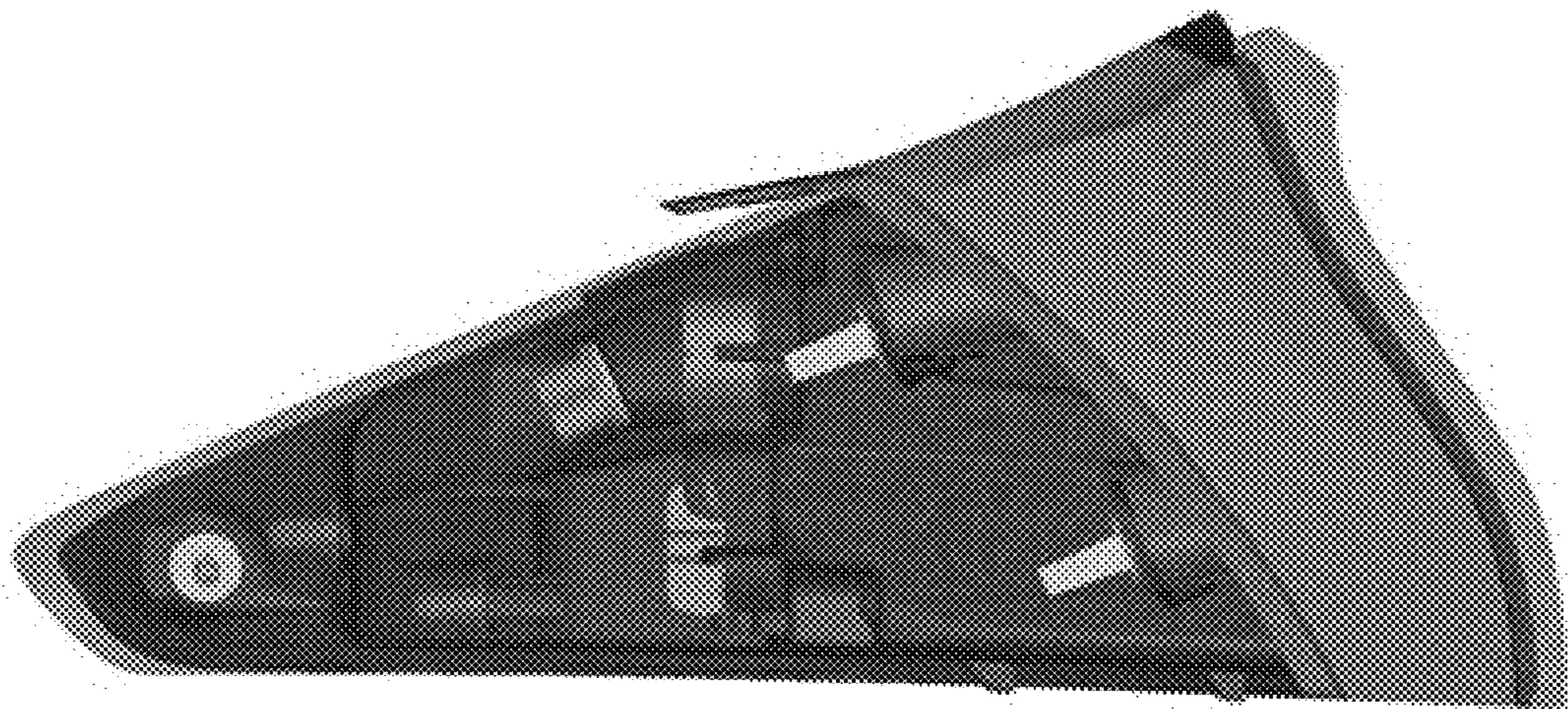

FIG. 5

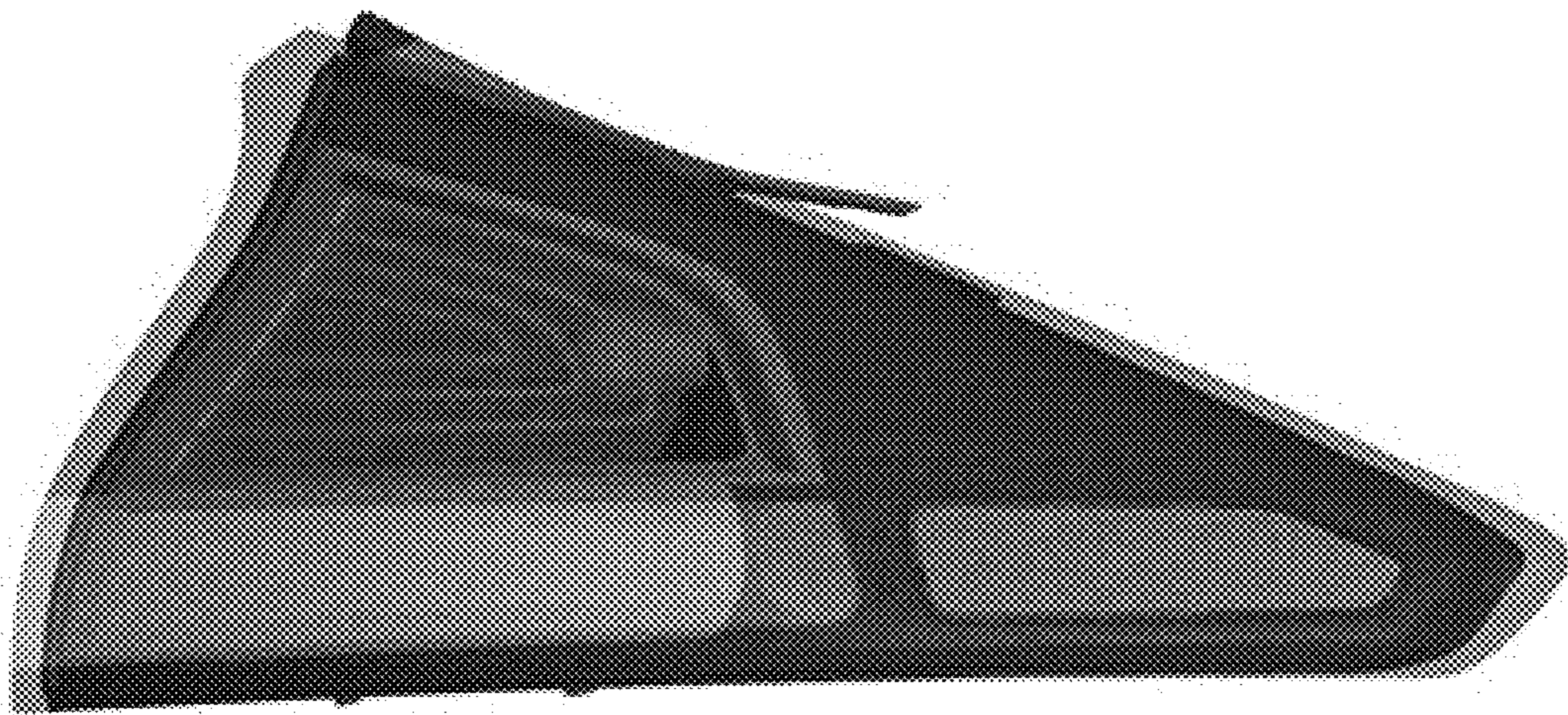

FIG. 6

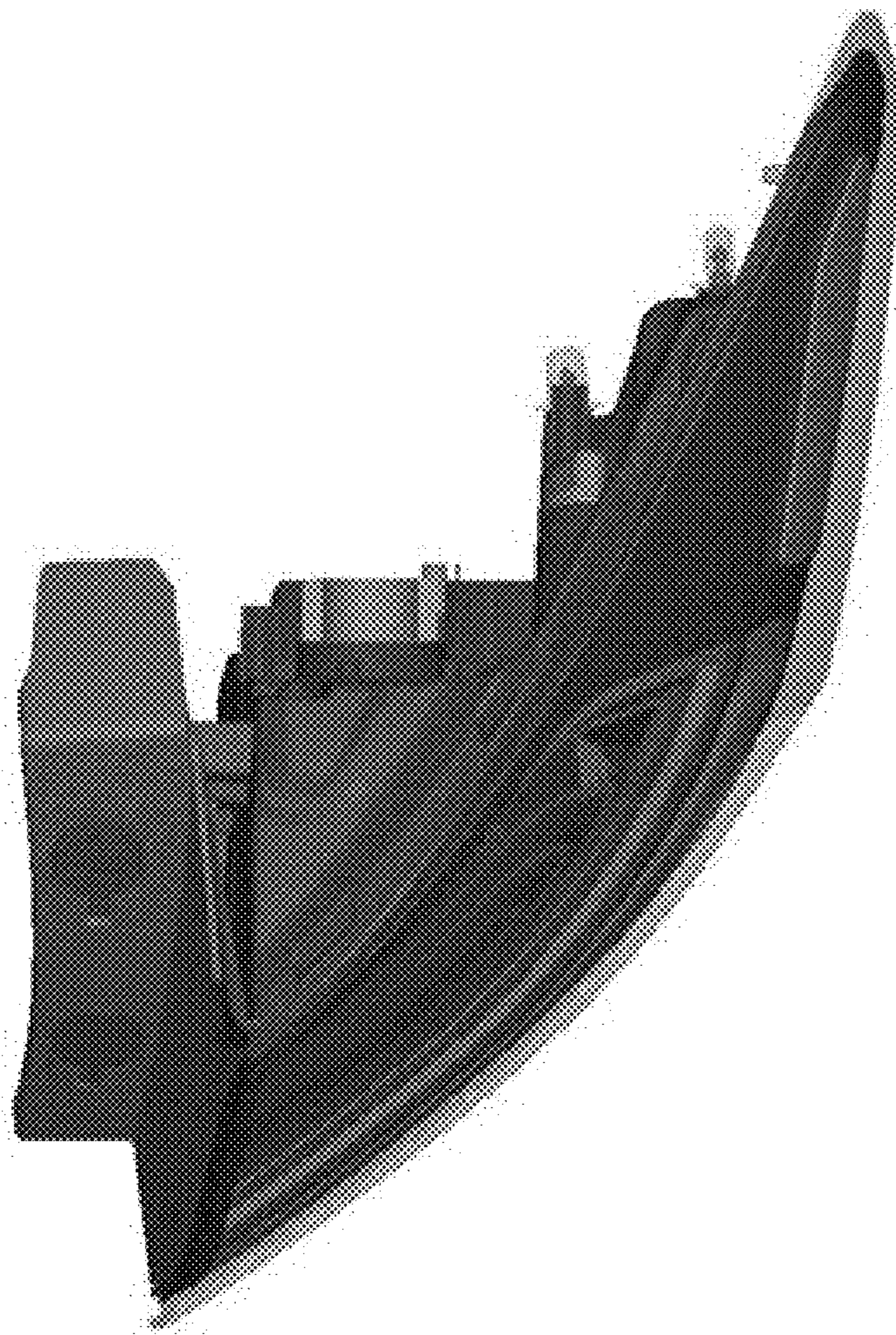

FIG. 7

