



US00D785541S

(12) **United States Design Patent** (10) **Patent No.:** **US D785,541 S**  
**Du et al.** (45) **Date of Patent:** **\*\* May 2, 2017**

(54) **AIRCRAFT**

(71) Applicant: **GUANGZHOU EHANG INTELLIGENT TECHNOLOGY CO., LTD.**, Guangzhou (CN)

(72) Inventors: **Hao Du**, Guangzhou (CN); **Zhiyi Li**, Guangzhou (CN); **Chunming Ma**, Guangzhou (CN)

(73) Assignee: **Guangzhou Ehang Intelligent Technology Co., Ltd.**, Guangzhou, Guangdong (CN)

(\*\*) Term: **15 Years**

(21) Appl. No.: **29/554,082**

(22) Filed: **Feb. 8, 2016**

(30) **Foreign Application Priority Data**

Dec. 25, 2015 (CN) ..... 2015 3 0558380

(51) **LOC (10) Cl.** ..... **12-07**

(52) **U.S. Cl.**  
USPC ..... **D12/328**

(58) **Field of Classification Search**  
USPC ..... D12/16.1, 319-345; D21/436, 441-444, D21/446-453  
CPC ..... B64C 1/062; B64C 39/024; B64C 27/08; B64C 29/00; B64C 39/00; B64C 23/00  
See application file for complete search history.

(56) **References Cited**

**U.S. PATENT DOCUMENTS**

D648,808 S \* 11/2011 Seydoux ..... D21/441  
D684,103 S \* 6/2013 Morelli ..... D12/319  
D692,797 S \* 11/2013 Ohnishi ..... D12/16.1  
D725,576 S \* 3/2015 Vickers ..... D12/3

D730,803 S \* 6/2015 Hoover ..... D12/326  
D739,807 S \* 9/2015 Strand ..... D12/324  
D756,842 S \* 5/2016 Ashjaee ..... D12/16.1  
D760,624 S \* 7/2016 Balaesque ..... D12/16.1  
D768,539 S \* 10/2016 Lee ..... D12/16.1  
D768,540 S \* 10/2016 Ji ..... D12/16.1  
9,493,225 B2 \* 11/2016 Wang ..... B64C 39/028  
2016/0194069 A1 \* 7/2016 Taylor ..... B64C 39/024  
244/17.23  
2016/0280369 A1 \* 9/2016 Pounds ..... A63H 27/00

**OTHER PUBLICATIONS**

Drone capable of carrying a human by Robin Andrews on IFL Science dated Aug. 1, 2016. found online [Dec. 7, 2016]http://www.iflscience.com/technology/self-flying-human-carrying-chinese-drone-unveiled-0/.\*

\* cited by examiner

*Primary Examiner* — Robert M Spear

*Assistant Examiner* — Marissa J Cash

(74) *Attorney, Agent, or Firm* — Hamre, Schumann, Mueller & Larson, P.C.

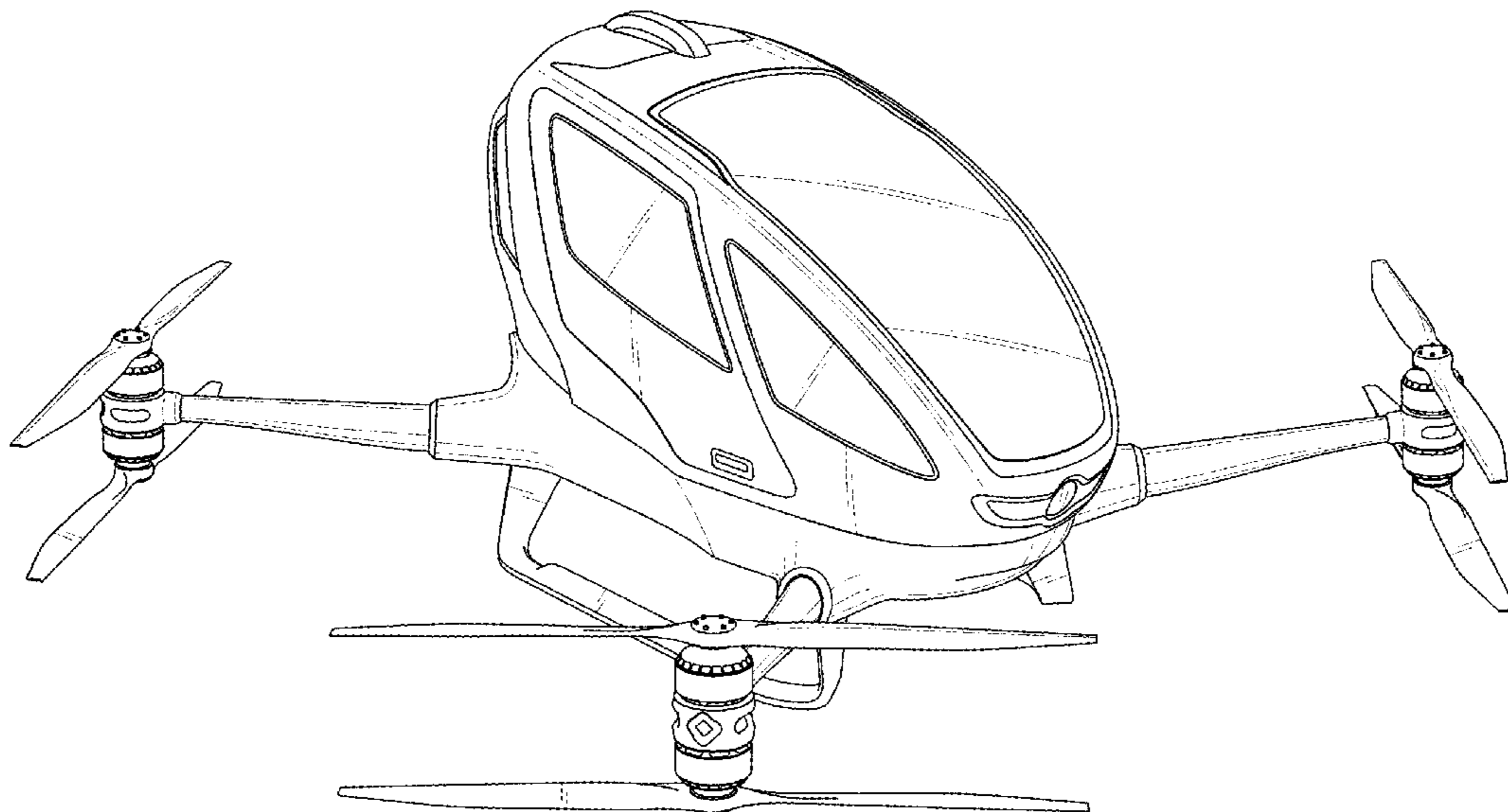
(57) **CLAIM**

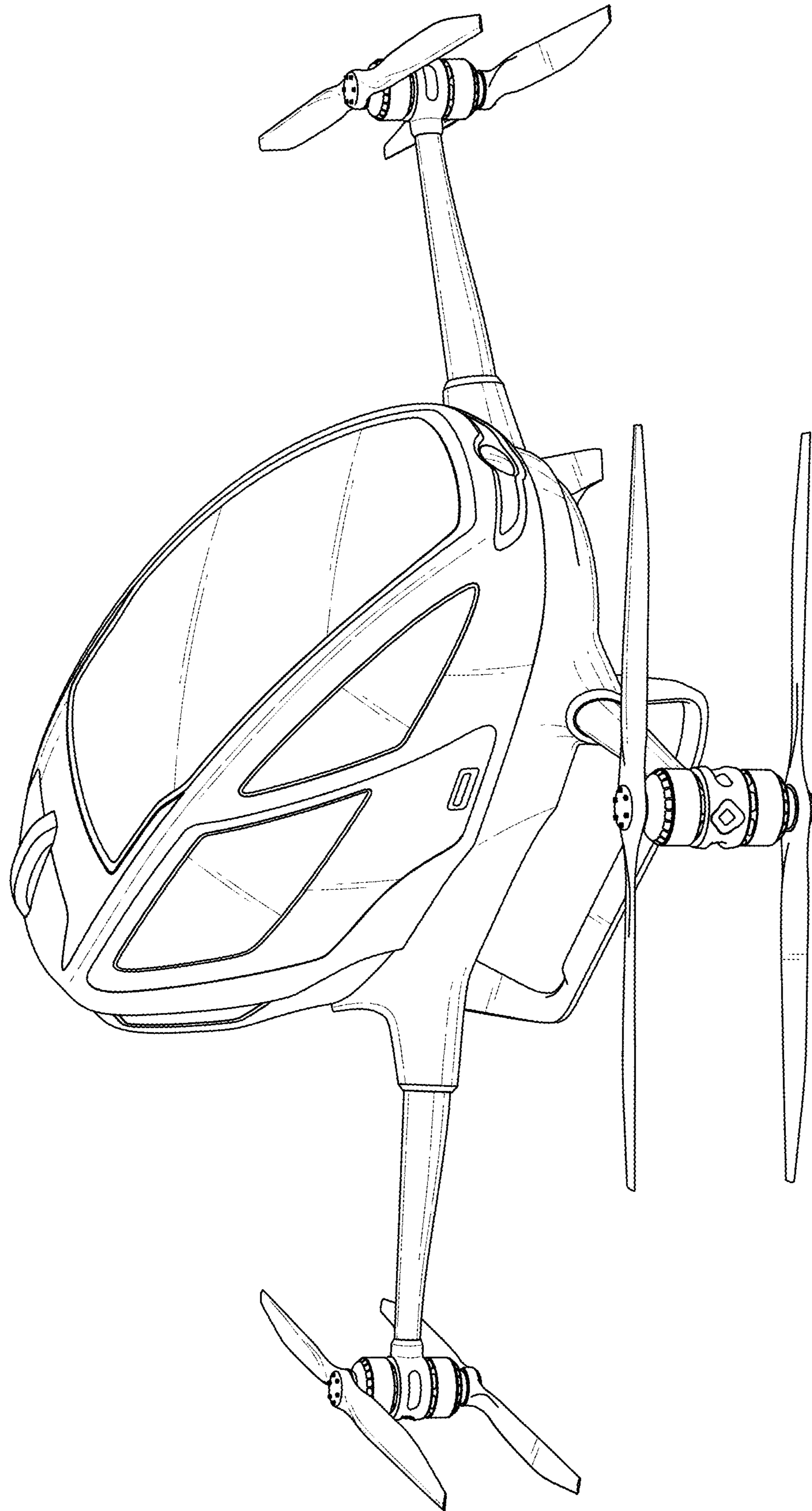
The ornamental design for an aircraft, as shown and described.

**DESCRIPTION**

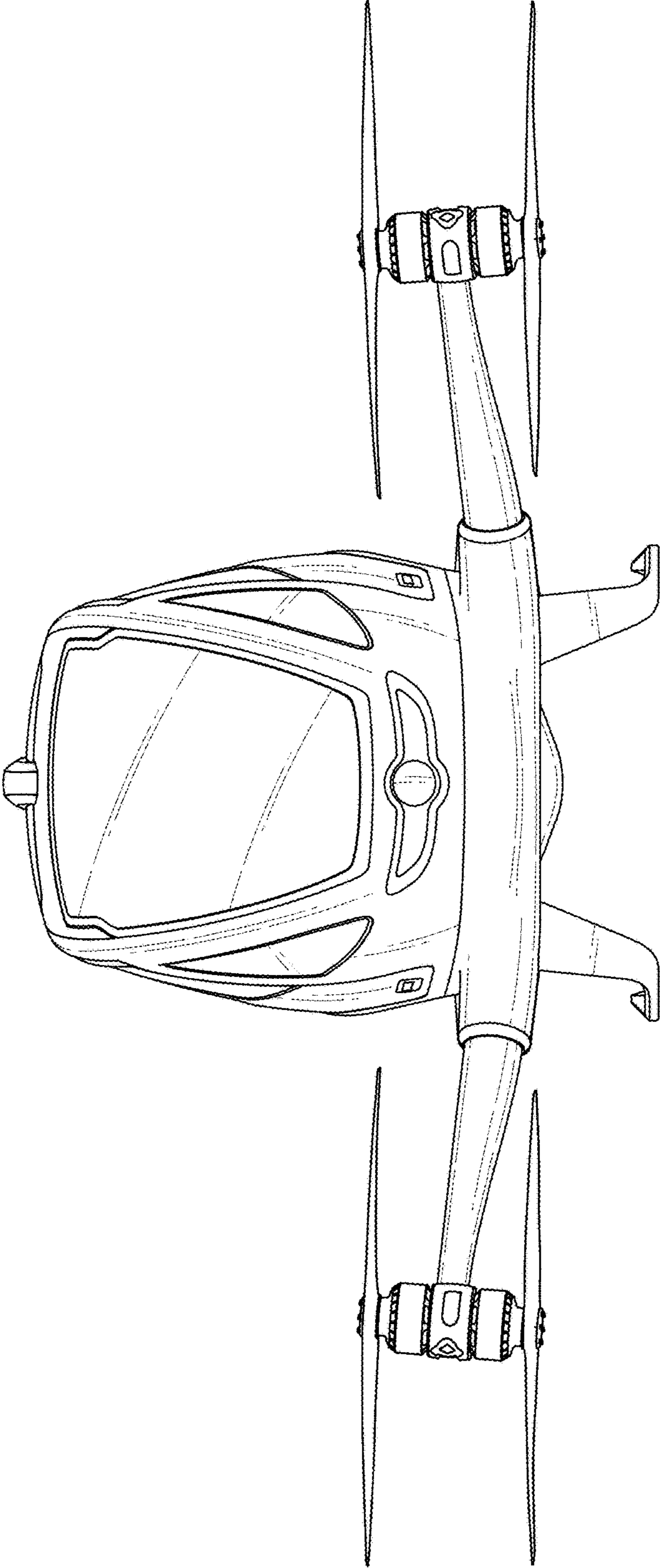
FIG. 1 is a perspective view of the aircraft;  
FIG. 2 is a front view thereof;  
FIG. 3 is a rear view thereof;  
FIG. 4 is a left side view, the right side being a mirror image thereof;  
FIG. 5 is a top view thereof; and,  
FIG. 6 is a bottom view thereof.  
The broken line showing of portions of the aircraft depict environment and forms no part of the claim.

**1 Claim, 6 Drawing Sheets**

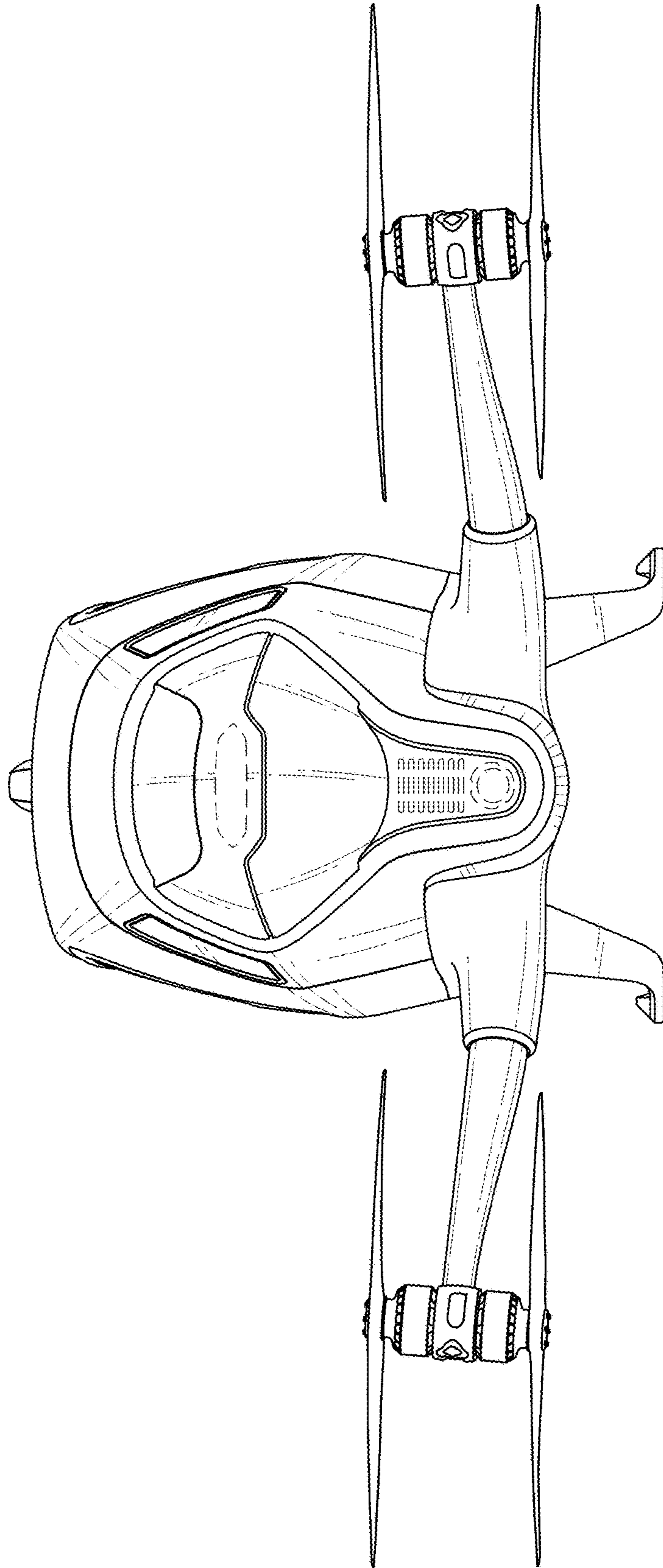




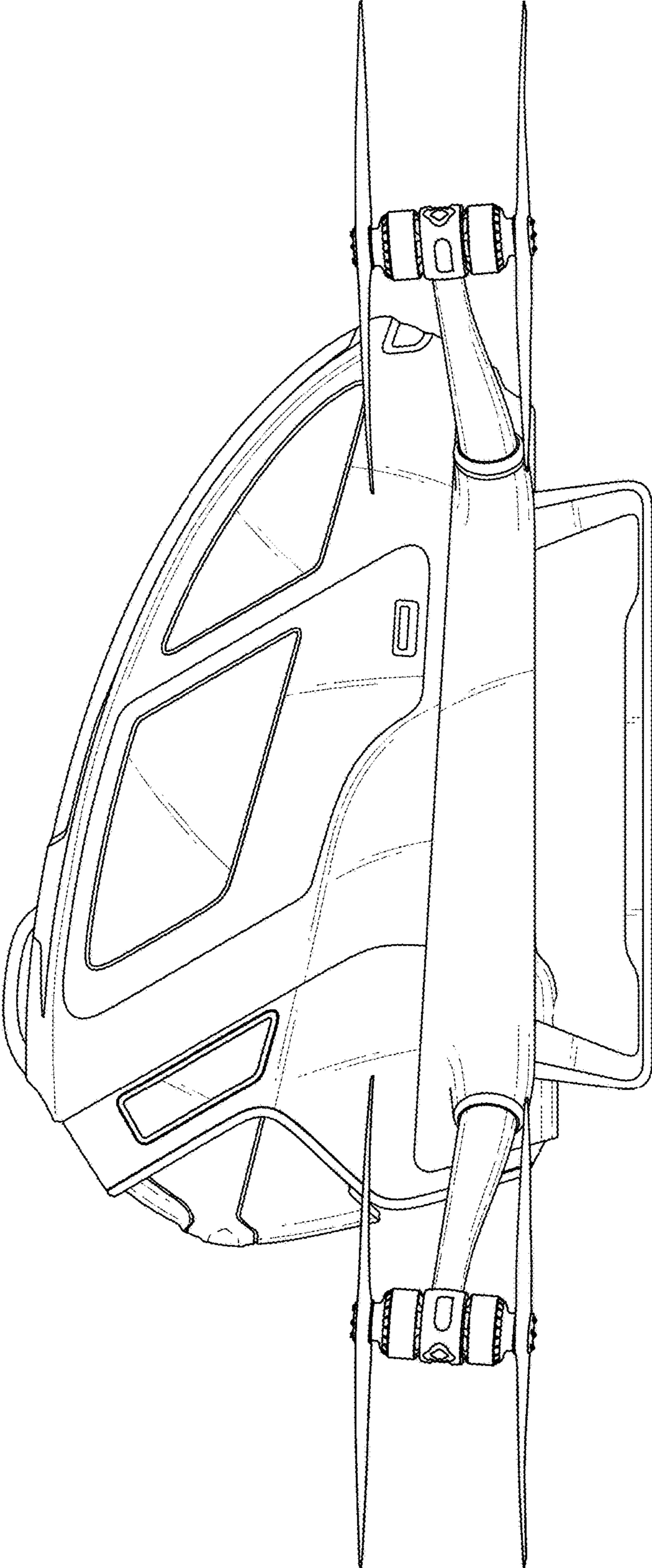
*Fig. 1*



*Fig. 2*

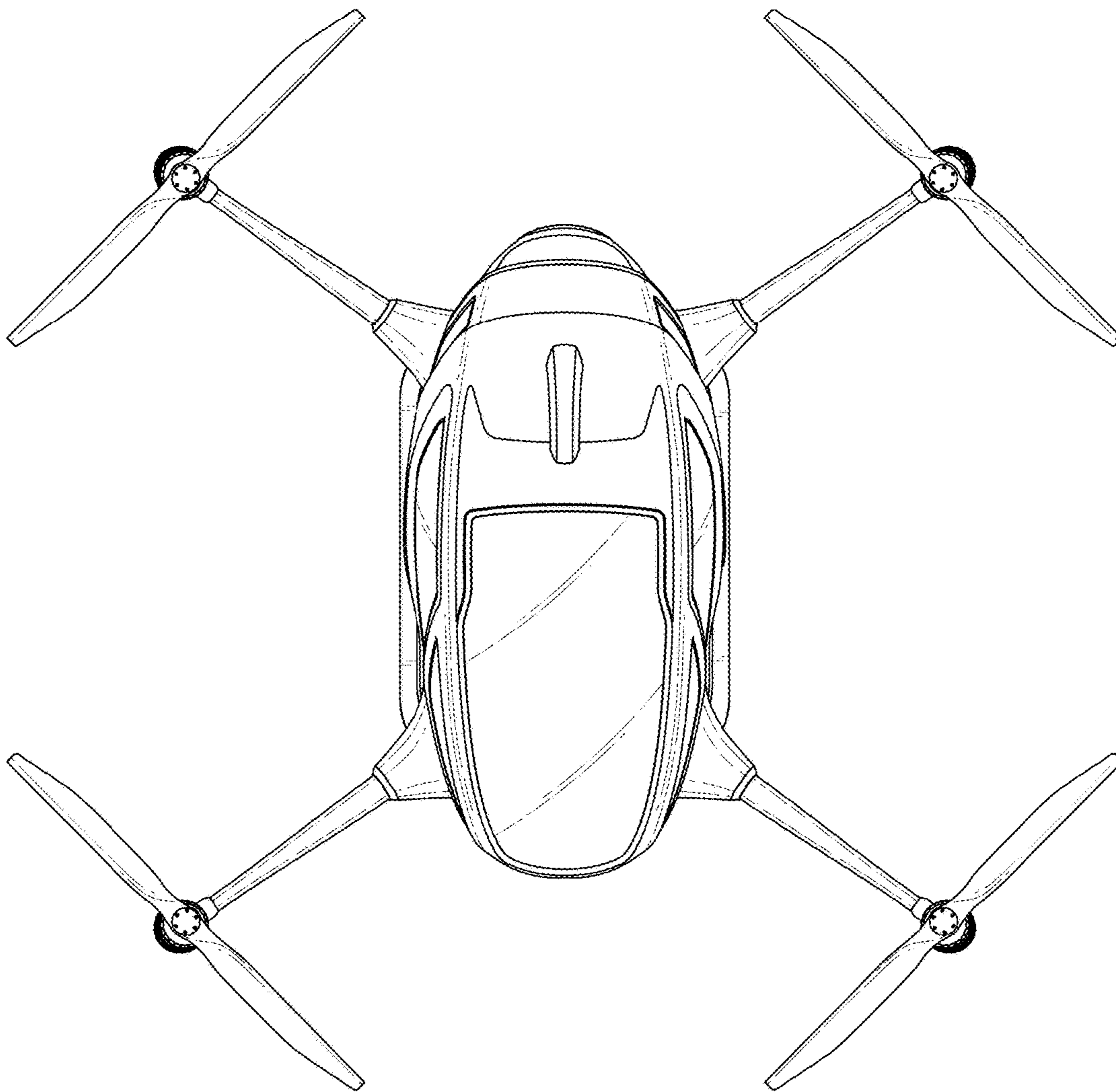


*Fig. 3*



*Fig. 4*

*Fig. 5*



*Fig. 6*

