



US00D785522S

(12) **United States Design Patent** (10) **Patent No.:** **US D785,522 S**
McMath (45) **Date of Patent:** **** May 2, 2017**

(54) **PAIR OF FRONT INSIDE FENDERS**

D524,203 S * 7/2006 Ichikawa D12/184

* cited by examiner

(71) Applicant: **Robert Roy McMath**, Riverside, CA
(US)

Primary Examiner — Daniel Bui

Assistant Examiner — Andrew Kerr

(72) Inventor: **Robert Roy McMath**, Riverside, CA
(US)

(74) *Attorney, Agent, or Firm* — Curtis L. Harrington;
Harrington & Harrington

(**) Term: **15 Years**

(57) **CLAIM**

The ornamental design for a pair of front inside fenders, as shown and described.

(21) Appl. No.: **29/553,695**

DESCRIPTION

(22) Filed: **Feb. 3, 2016**

(51) **LOC (10) Cl.** **12-08**

(52) **U.S. Cl.**

USPC **D12/181**

(58) **Field of Classification Search**

USPC D12/181, 184; 280/847, 849, 727

CPC B62D 25/184; B62D 25/14; B62D 25/182;

B62D 25/18

See application file for complete search history.

FIG. 1 is a front side perspective view of a pair of front inside fenders, in use condition showing my new design; FIG. 2 is a top, front side perspective view thereof; FIG. 3 is a front side elevation view thereof; FIG. 4 is a rear side elevation view thereof; FIG. 5 is a left side elevation view thereof; FIG. 6 is a right side elevation view thereof; FIG. 7 is a top plan view thereof; and, FIG. 8 is a bottom plan view thereof.

The dash-dash even broken lines illustrate and surround portions of the pair of front inside fenders that form no part of the claimed design. The dash-dot-dot broken lines shown in the drawings illustrate vehicle environmental subject matter which forms no part of the claimed design.

(56) **References Cited**

U.S. PATENT DOCUMENTS

D252,458 S * 7/1979 Laine D12/184

D252,459 S * 7/1979 Laine D12/184

D286,867 S * 11/1986 Envall D12/184

D286,868 S * 11/1986 Envall D12/184

1 Claim, 3 Drawing Sheets

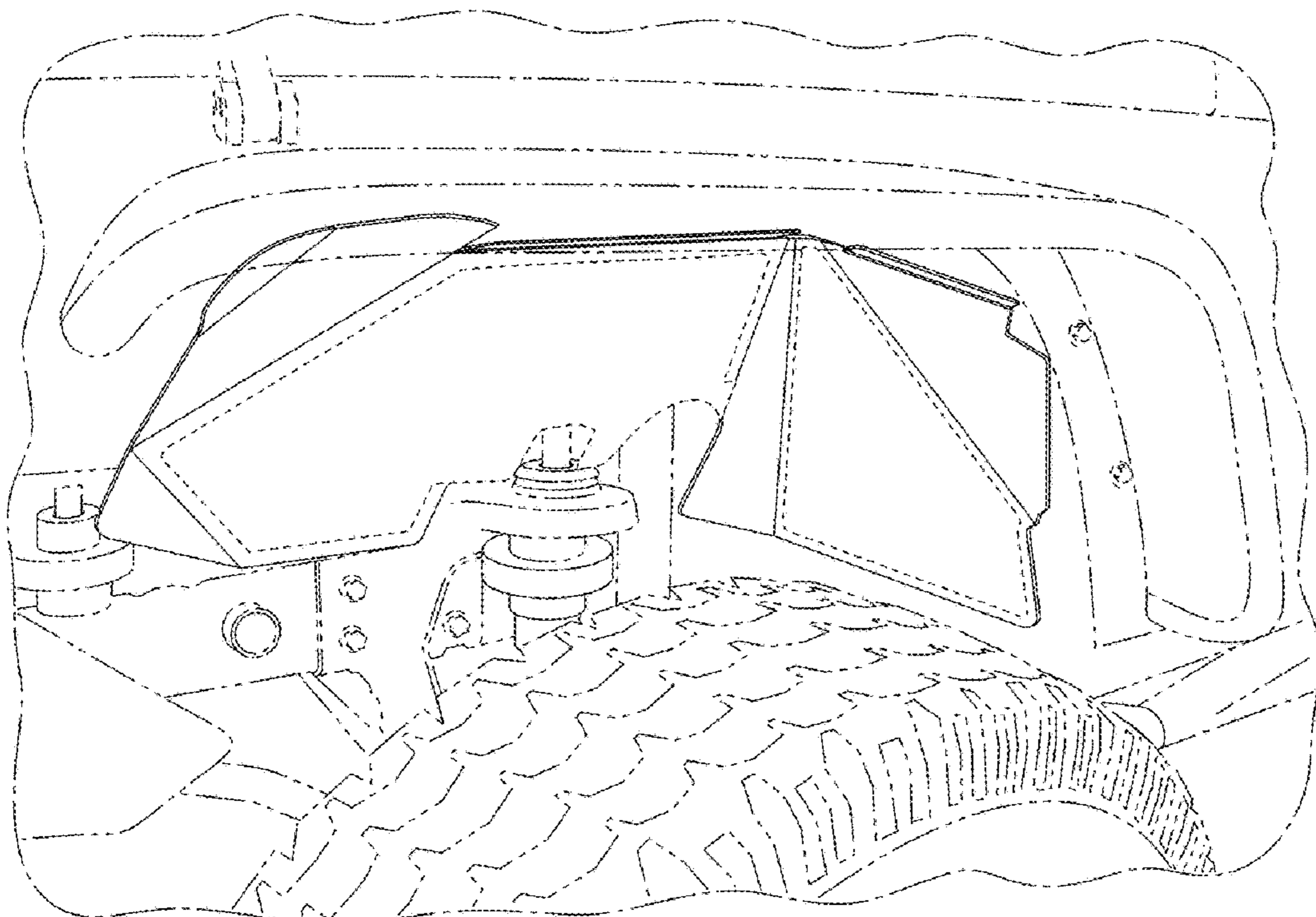

Fig. 1

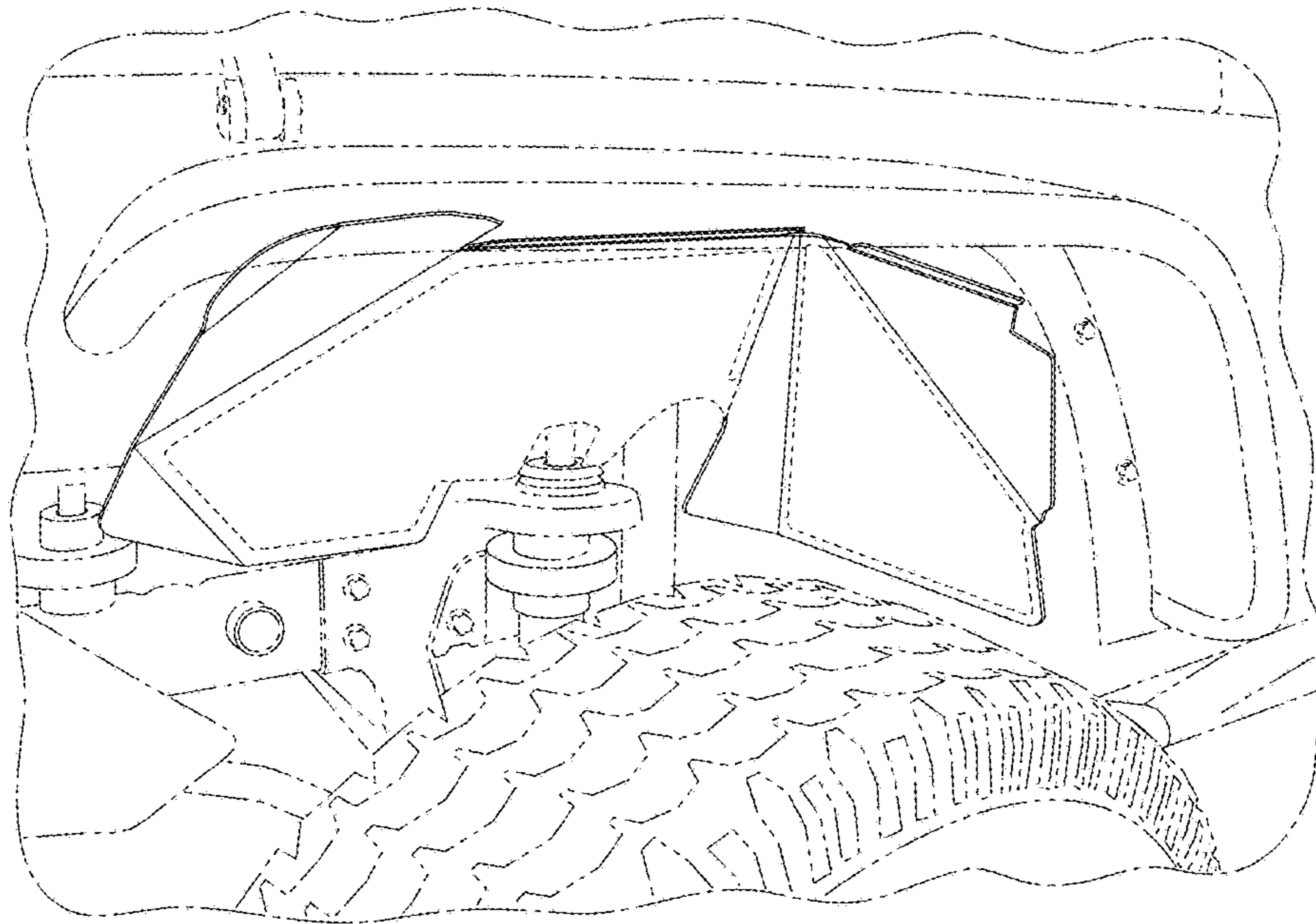

Fig. 2

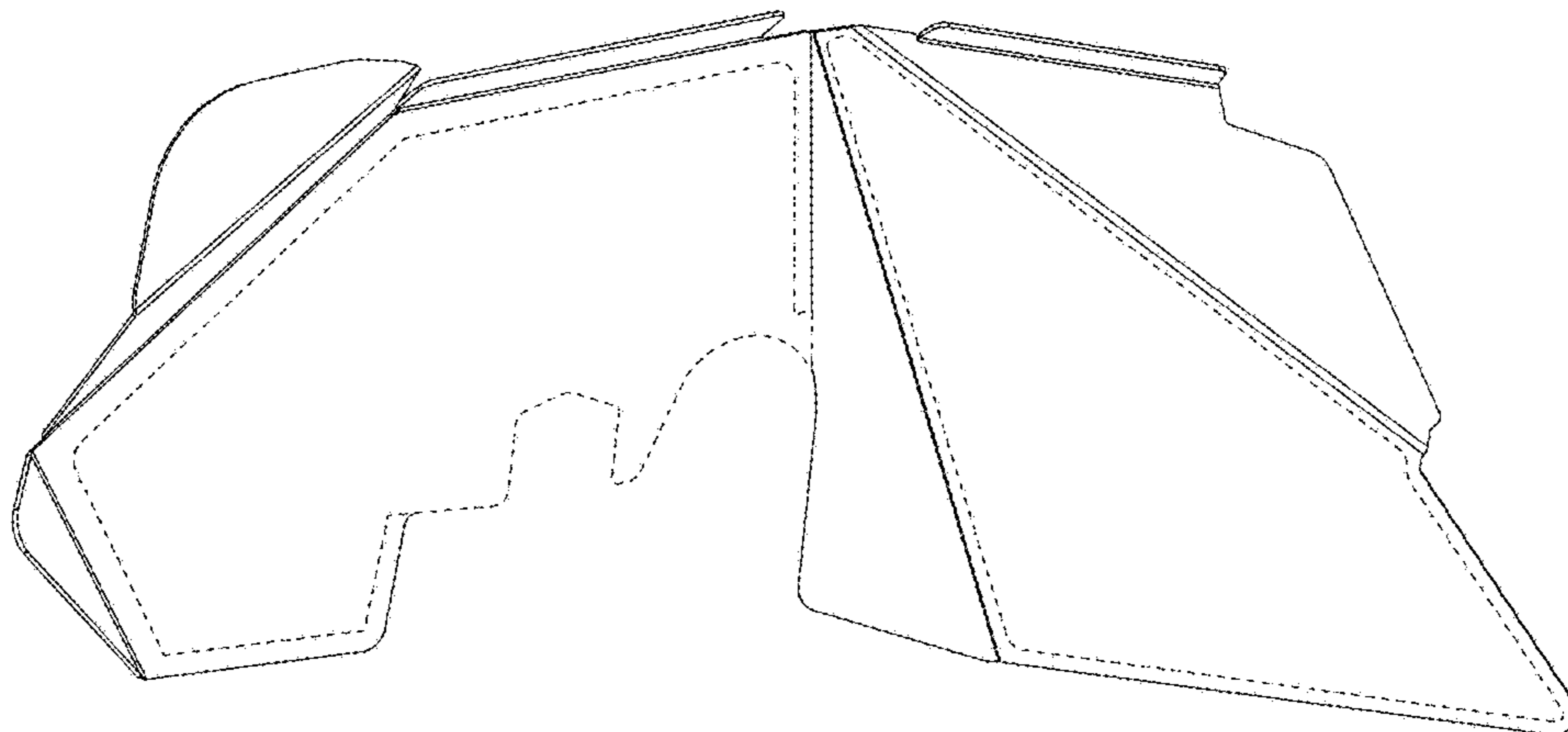

Fig. 3

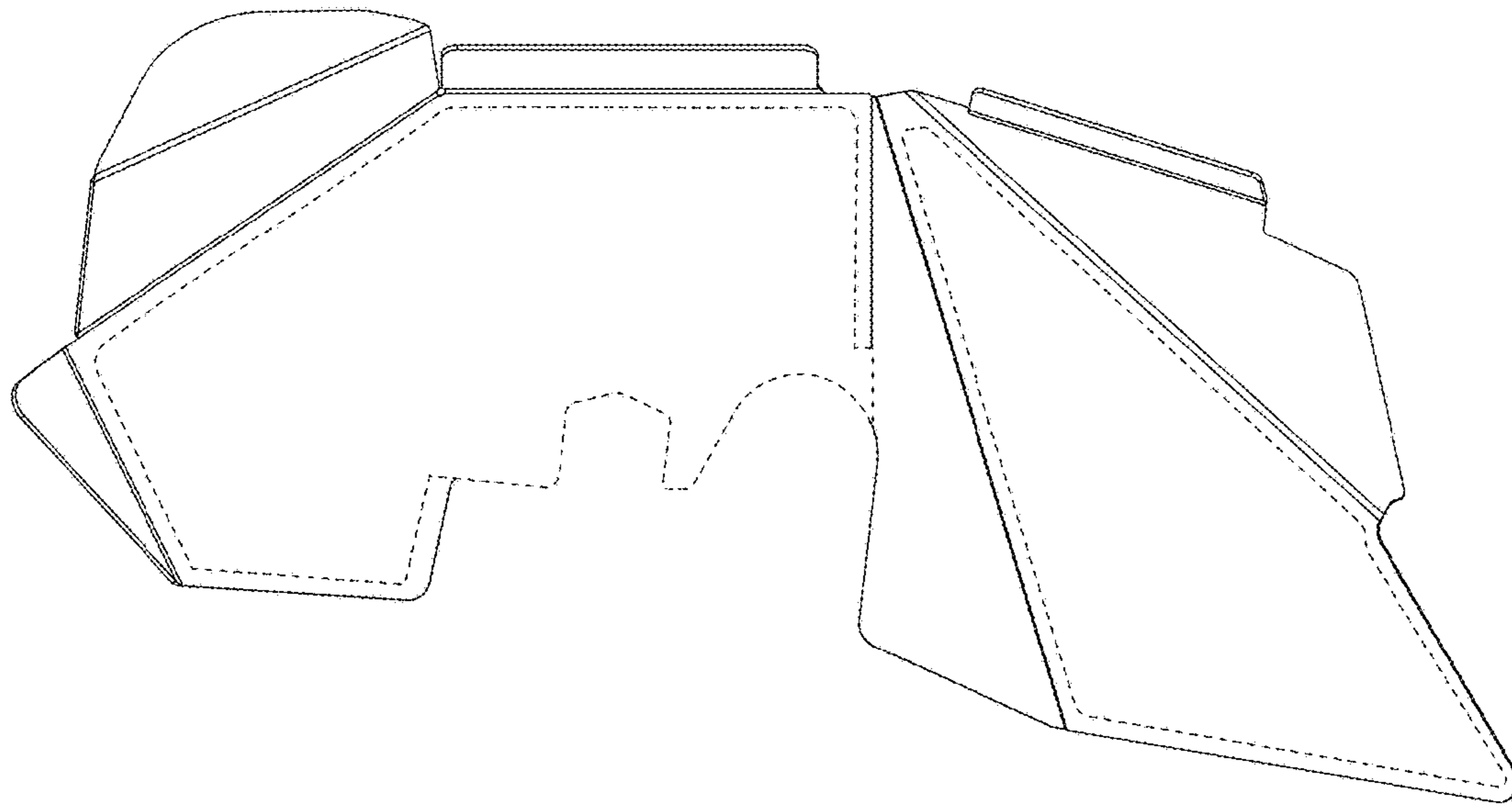

Fig. 4

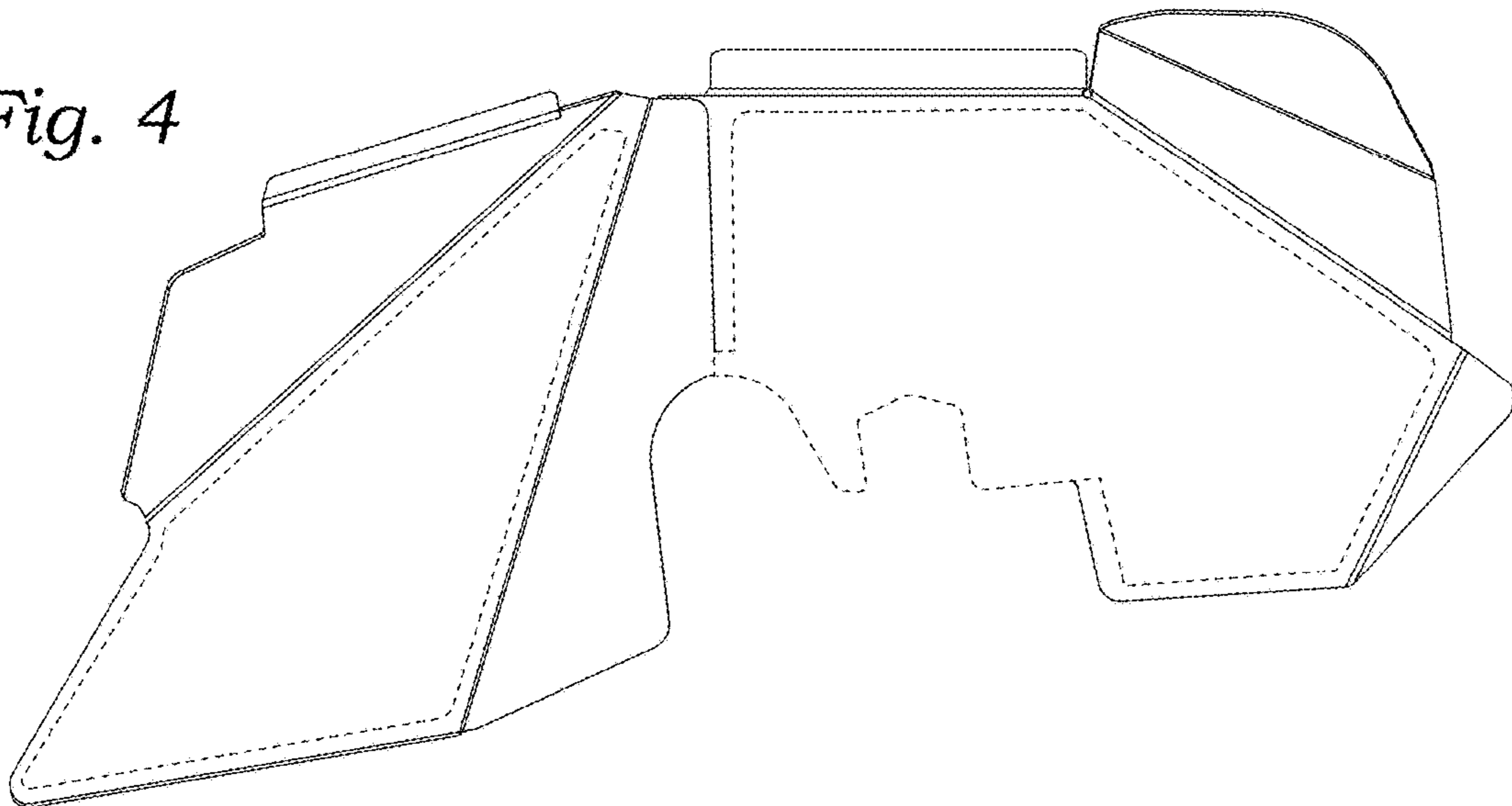

Fig. 5

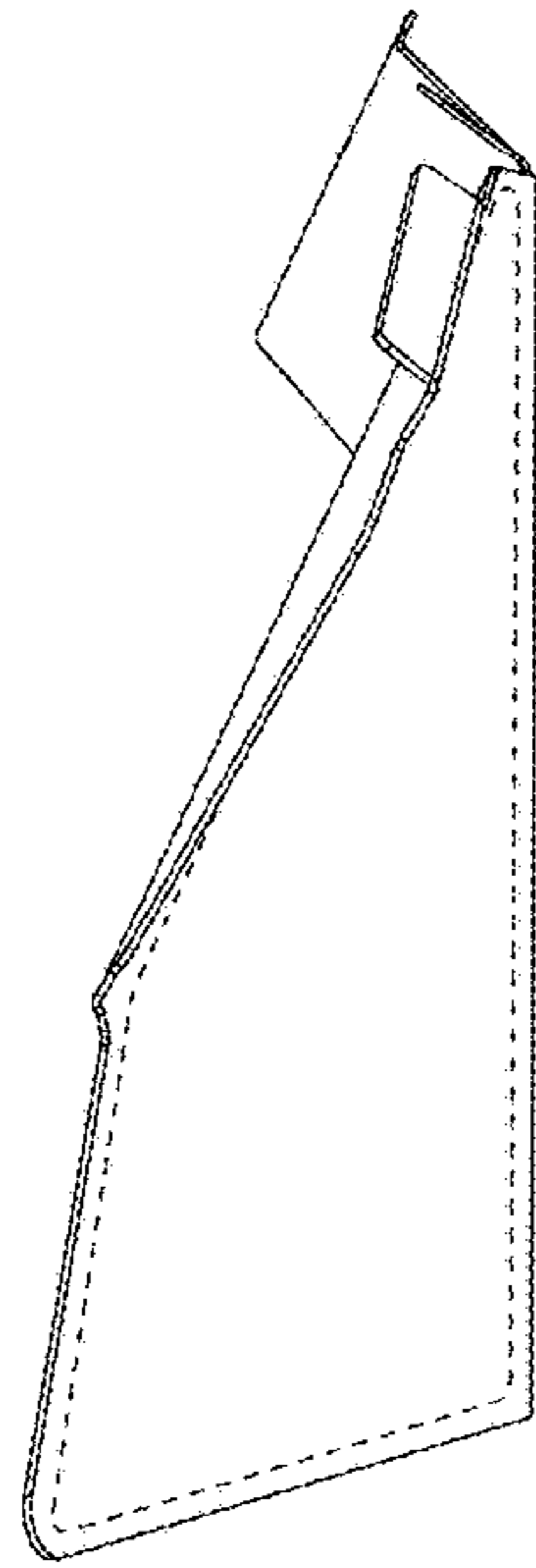

Fig. 6

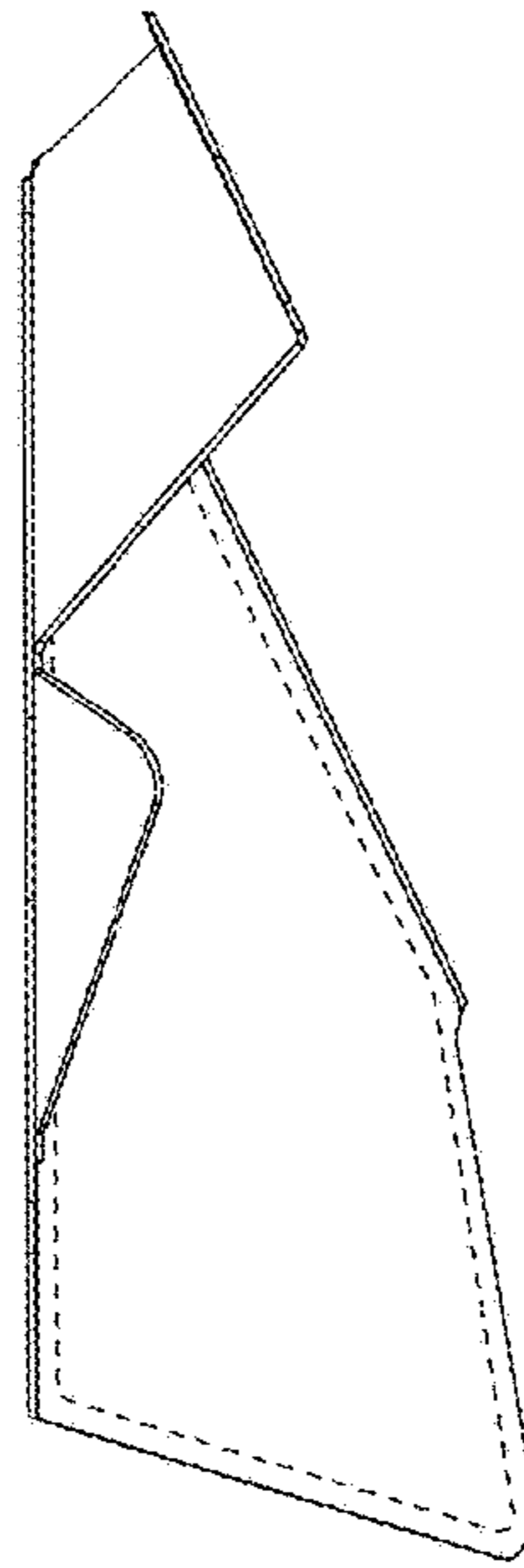

Fig. 7

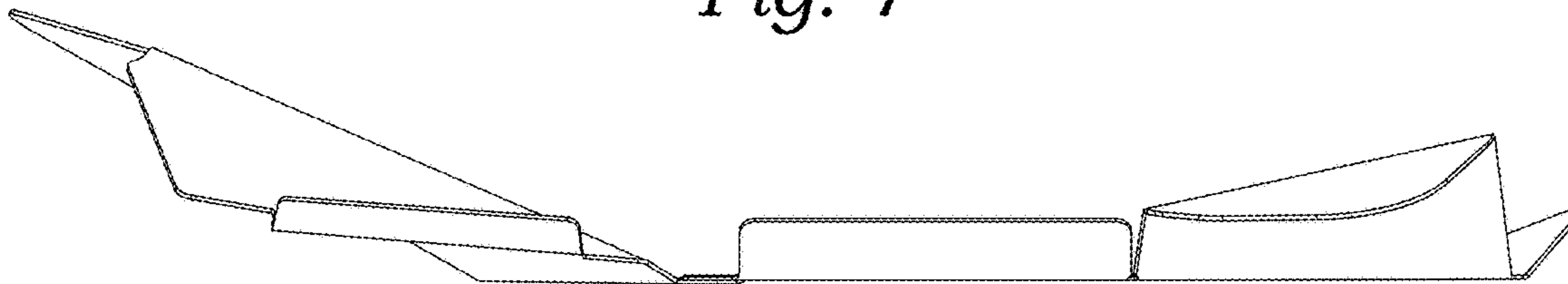

Fig. 8

