



US00D785146S

(12) **United States Design Patent** (10) **Patent No.:** **US D785,146 S**  
**Kurz** (45) **Date of Patent:** **\*\* Apr. 25, 2017**

- (54) **SINK TOP**
- (71) Applicant: **Ronbow Corporation**, Fremont, CA (US)
- (72) Inventor: **Dorian Kurz**, Solingen (DE)
- (73) Assignee: **RONBOW CORPORATION**, Fremont, CA (US)
- (\*\*) Term: **15 Years**
- (21) Appl. No.: **29/560,155**
- (22) Filed: **Apr. 4, 2016**
- (51) **LOC (10) Cl.** ..... **23-02**
- (52) **U.S. Cl.**  
USPC ..... **D23/287**
- (58) **Field of Classification Search**  
USPC ..... D23/270-273, 284, 286-287, 285, 303, D23/308  
CPC ... E03D 11/12; E03C 1/14; E03C 1/18; E03C 1/182  
See application file for complete search history.

- (56) **References Cited**  
U.S. PATENT DOCUMENTS  
D463,538 S \* 9/2002 Chipperfield ..... D23/284  
6,986,171 B1 \* 1/2006 Perrin ..... E03D 11/12  
4/300.2

- D630,715 S \* 1/2011 Thomas ..... D23/284
- D636,855 S \* 4/2011 Thomas ..... D23/293.1
- D697,596 S \* 1/2014 Spangler ..... D23/293.1
- \* cited by examiner

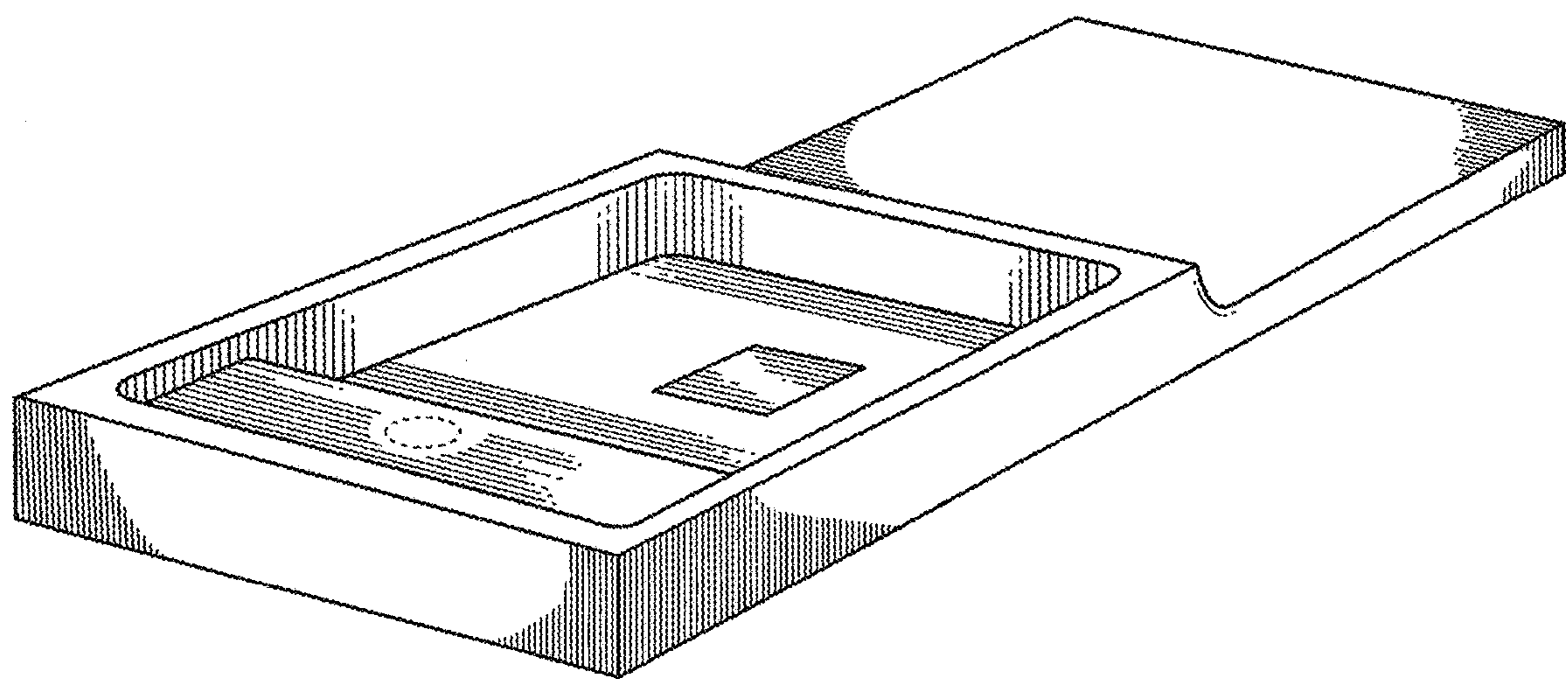
*Primary Examiner* — Robert Delehanty  
(74) *Attorney, Agent, or Firm* — Thomas Schneck

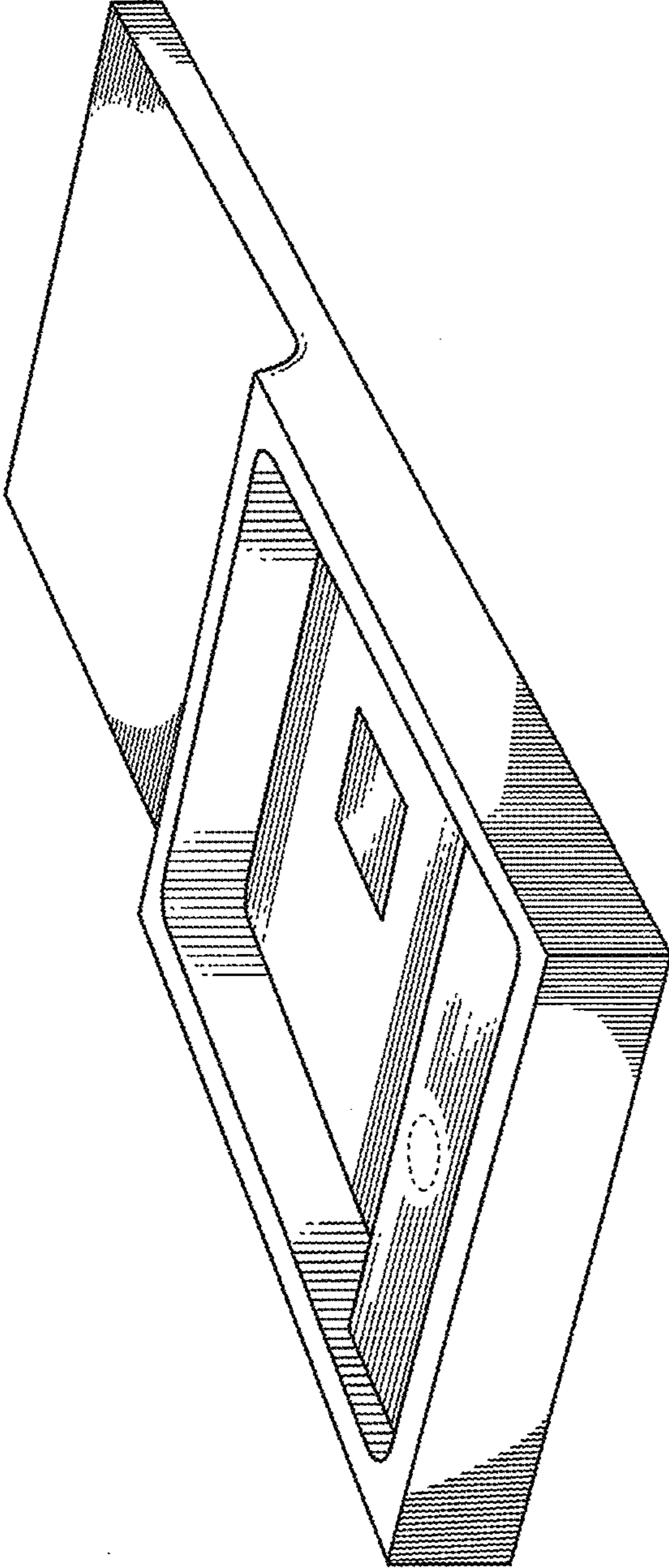
(57) **CLAIM**  
I claim the design for a sink top, as shown and described.

**DESCRIPTION**

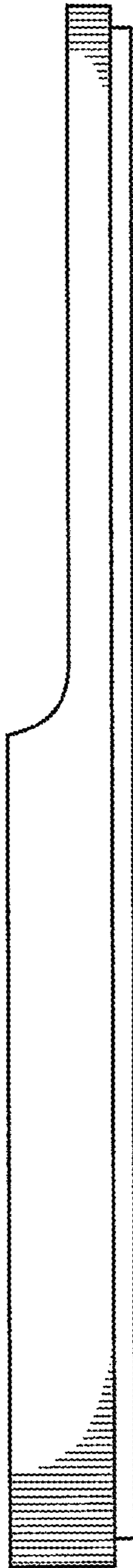
FIG. 1 is an upper front left perspective view of a sink top of my design, the dashed lines representing unclaimed features;  
 FIG. 2 is an enlarged front plan view thereof, the rear plan view being a mirror image thereof;  
 FIG. 3 is an enlarged left side plan view thereof;  
 FIG. 4 is an enlarged right side plan view thereof;  
 FIG. 5 is a top plan view thereof;  
 FIG. 6 is a bottom plan view thereof;  
 FIG. 7 is an upper front left perspective view of a second embodiment of a sink top of my design;  
 FIG. 8 is an enlarged front plan view thereof, the rear plan view being a mirror image thereof;  
 FIG. 9 is an enlarged left side plan view thereof;  
 FIG. 10 is an enlarged right side plan view thereof;  
 FIG. 11 is a top plan view thereof; and,  
 FIG. 12 is a bottom plan view thereof.  
 The broken lines shown in the drawings are included for the purpose of illustrating a portion of the sink that forms no part of the claimed design.

**1 Claim, 10 Drawing Sheets**

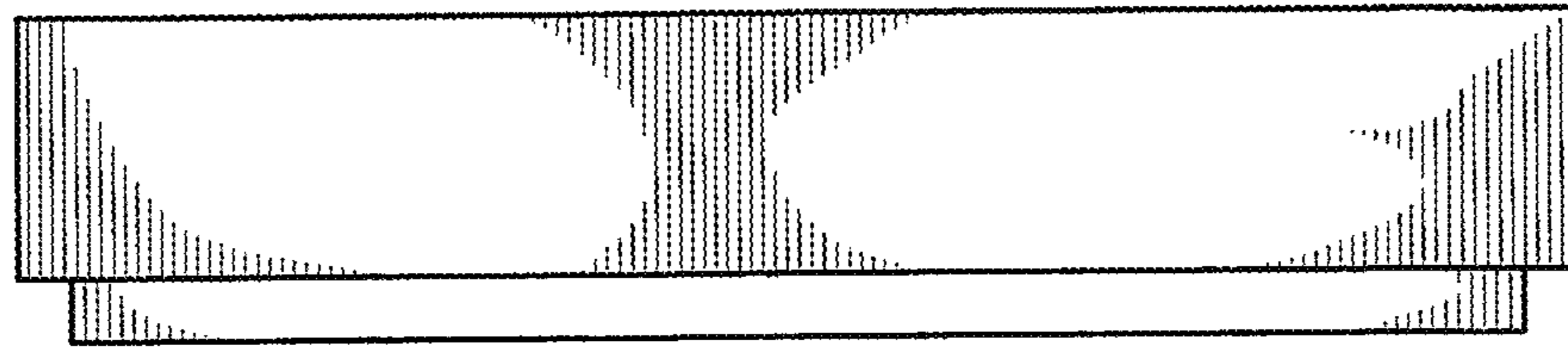




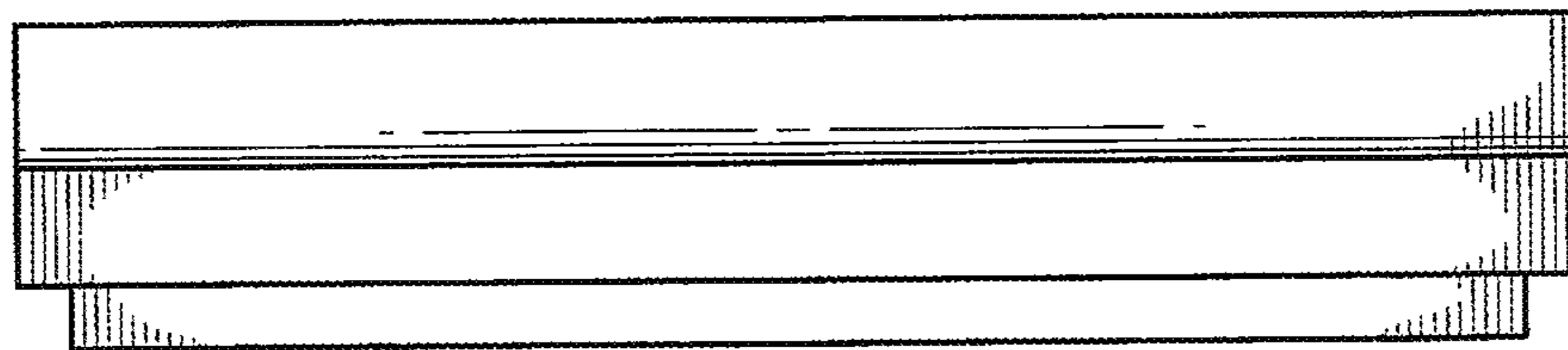
*Fig. 1*



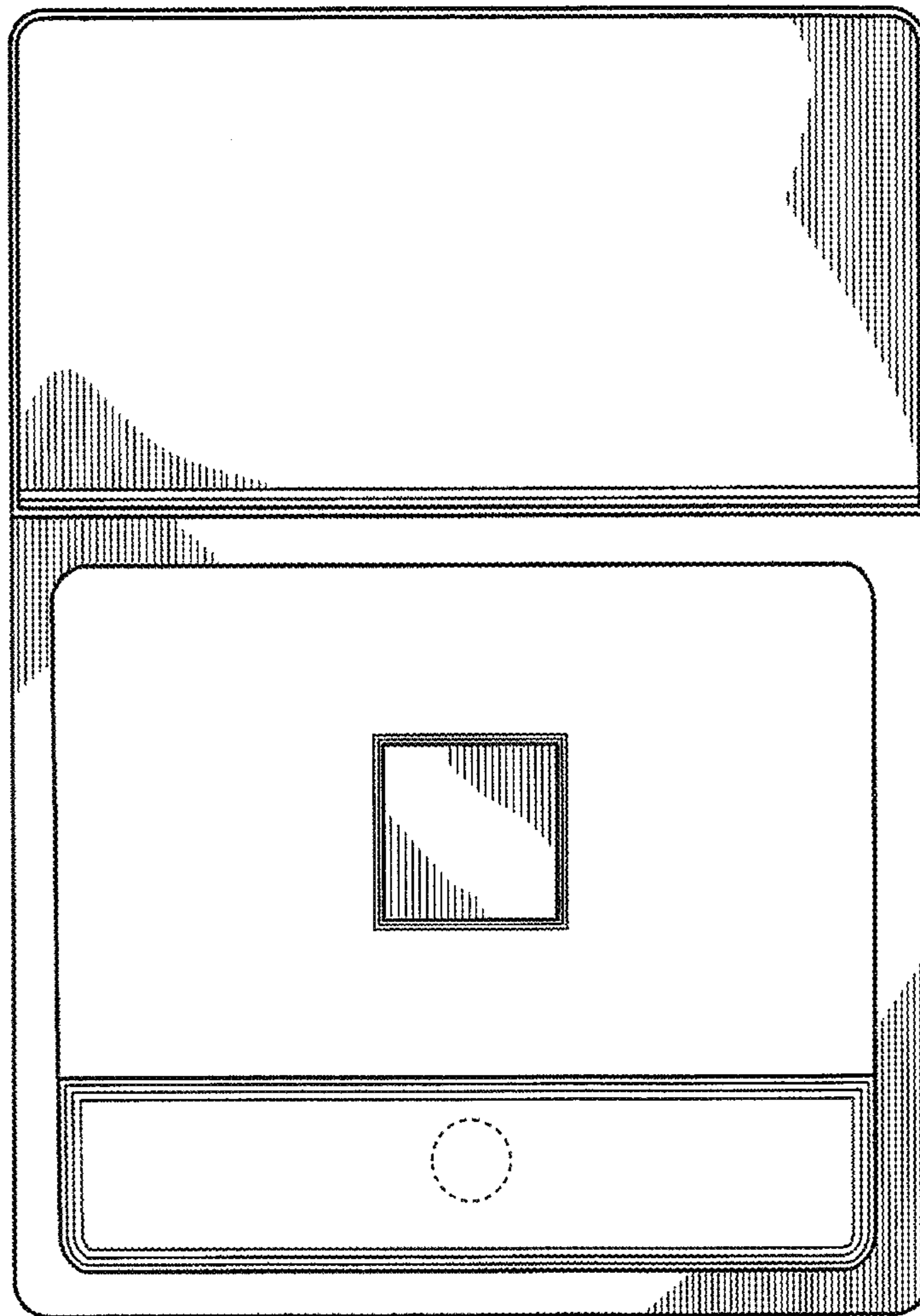
*Fig. 2*



*Fig. 3*

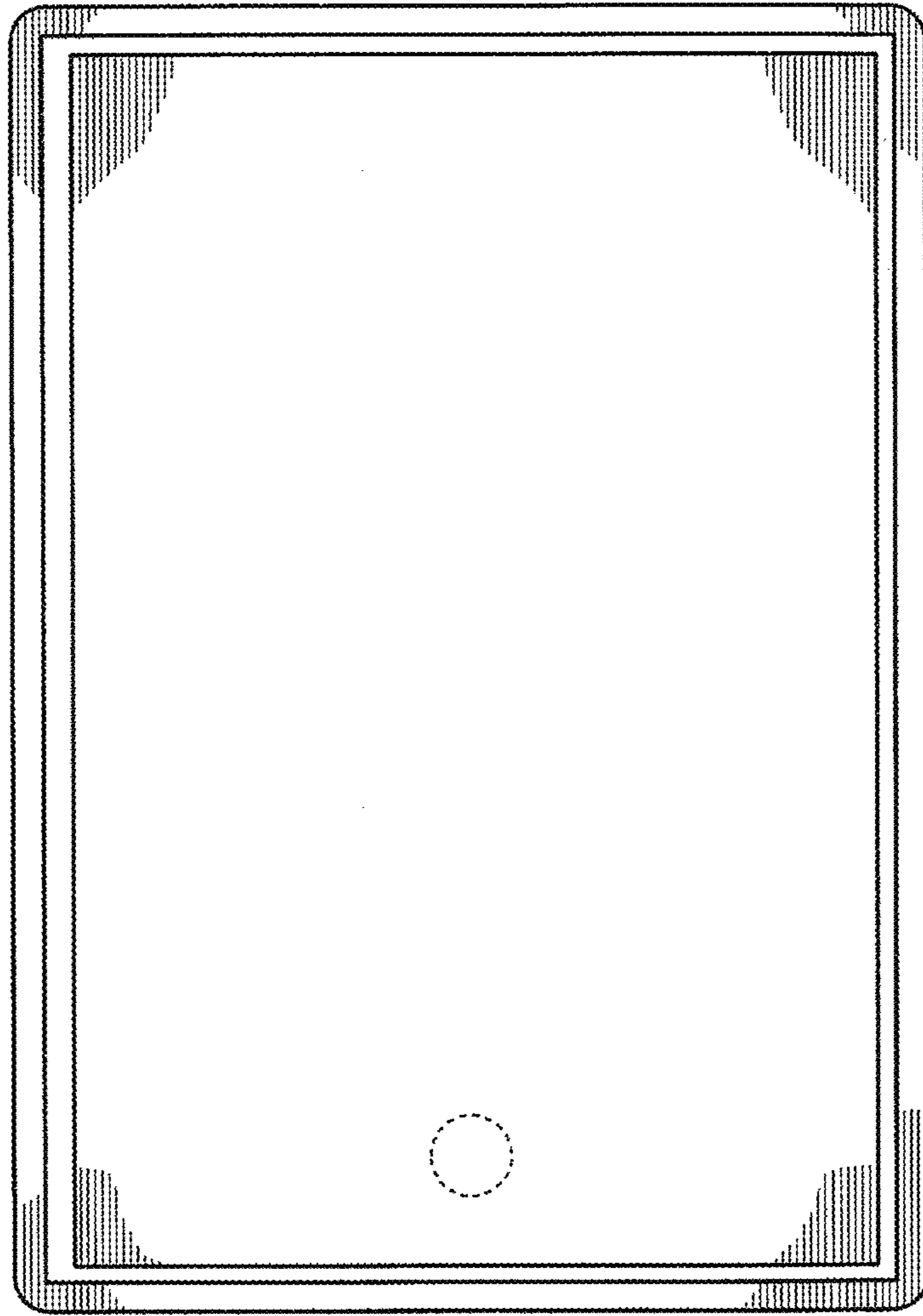


*Fig. 4*



*Fig. 5*





*Fig. 6*

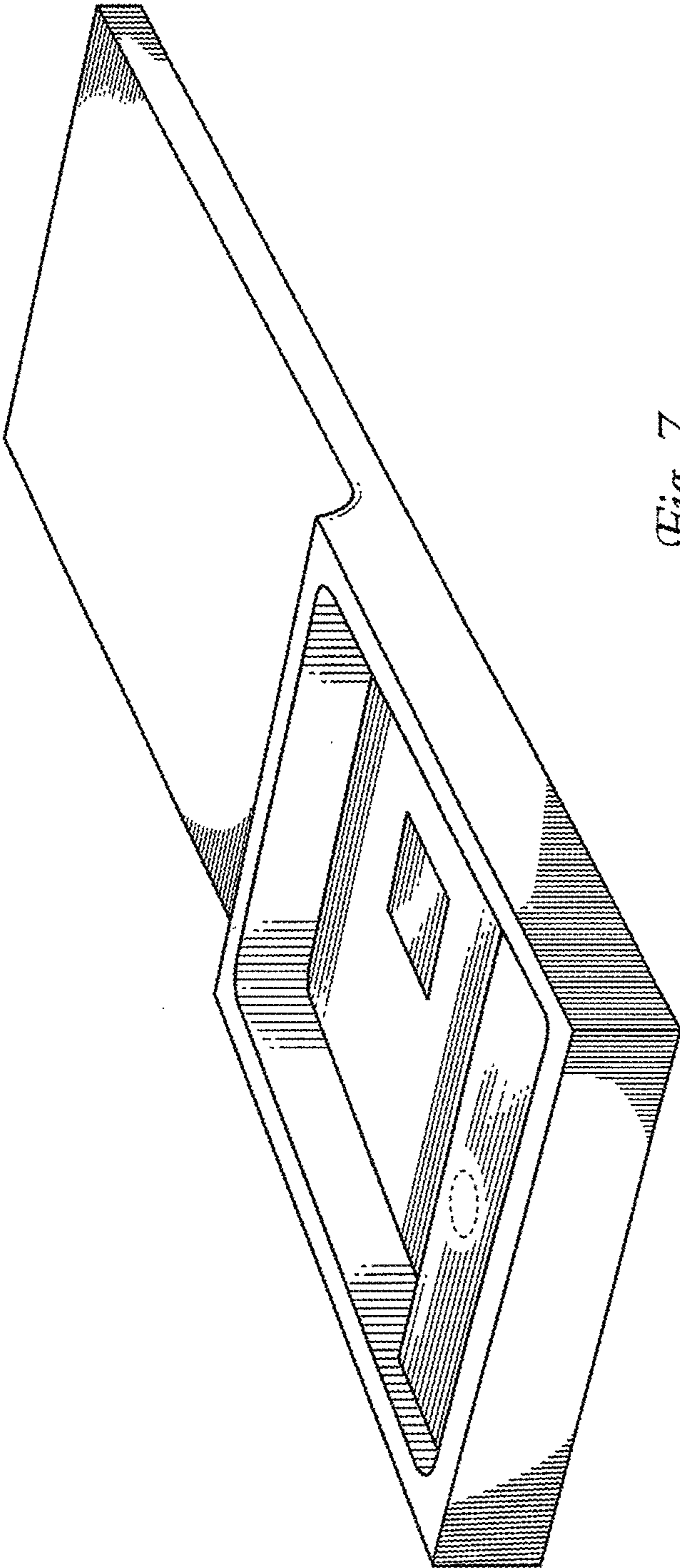
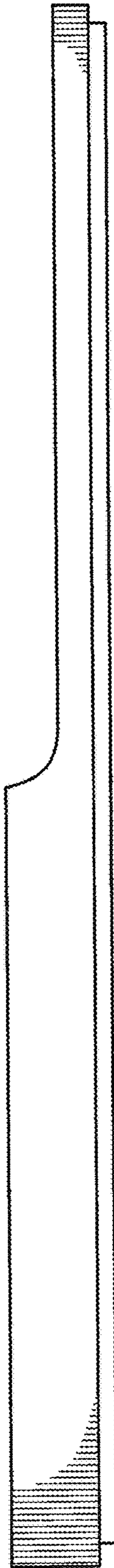
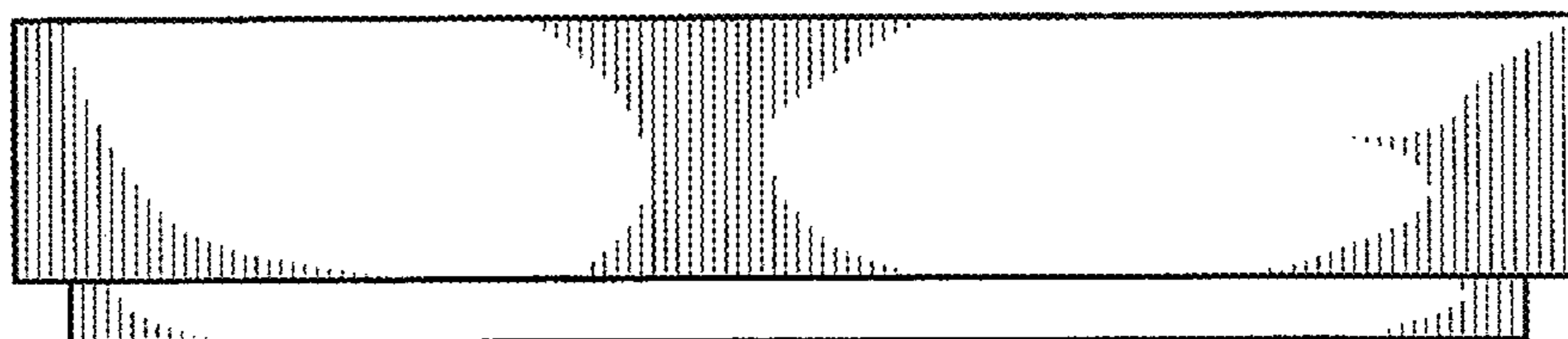


Fig. 7

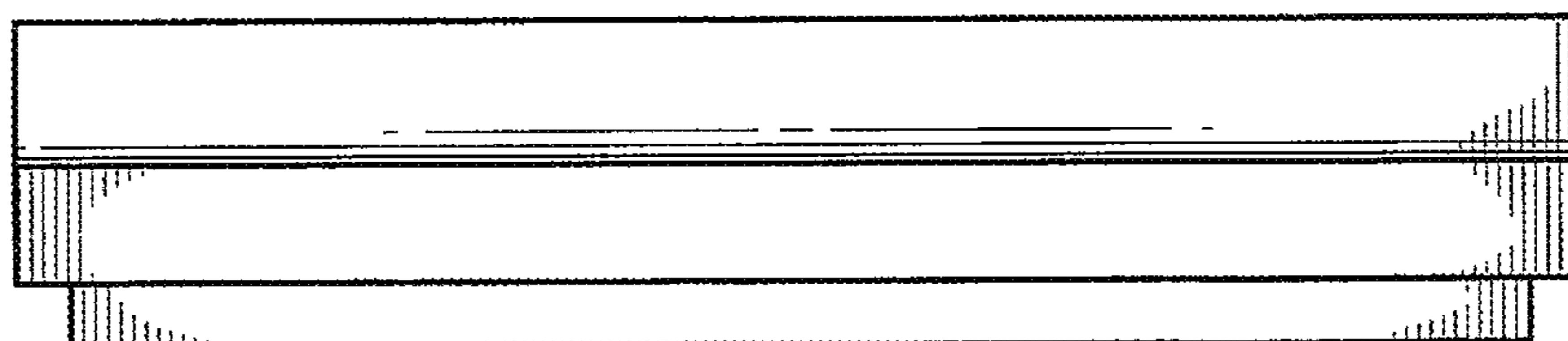


*Fig. 8*

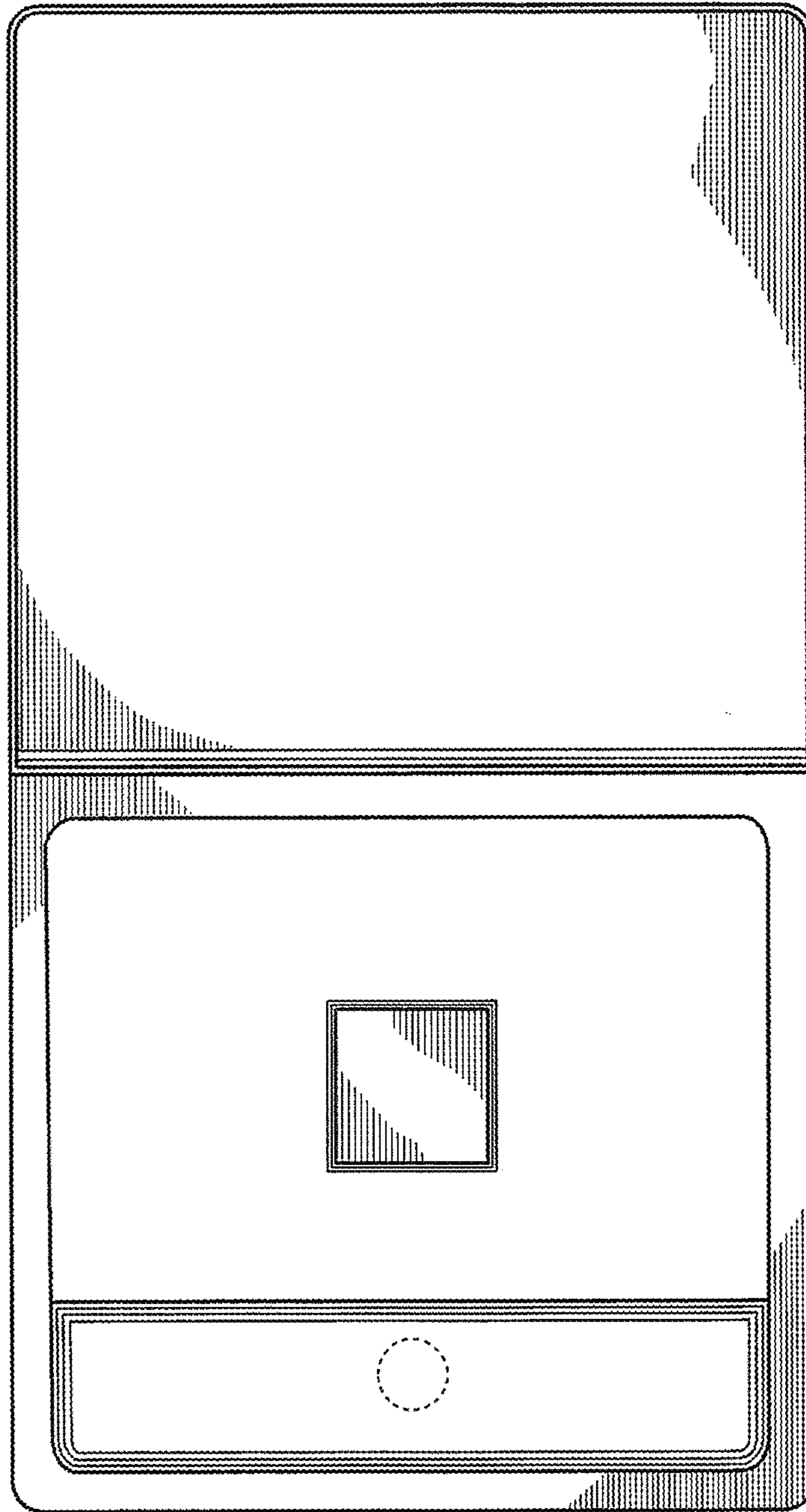




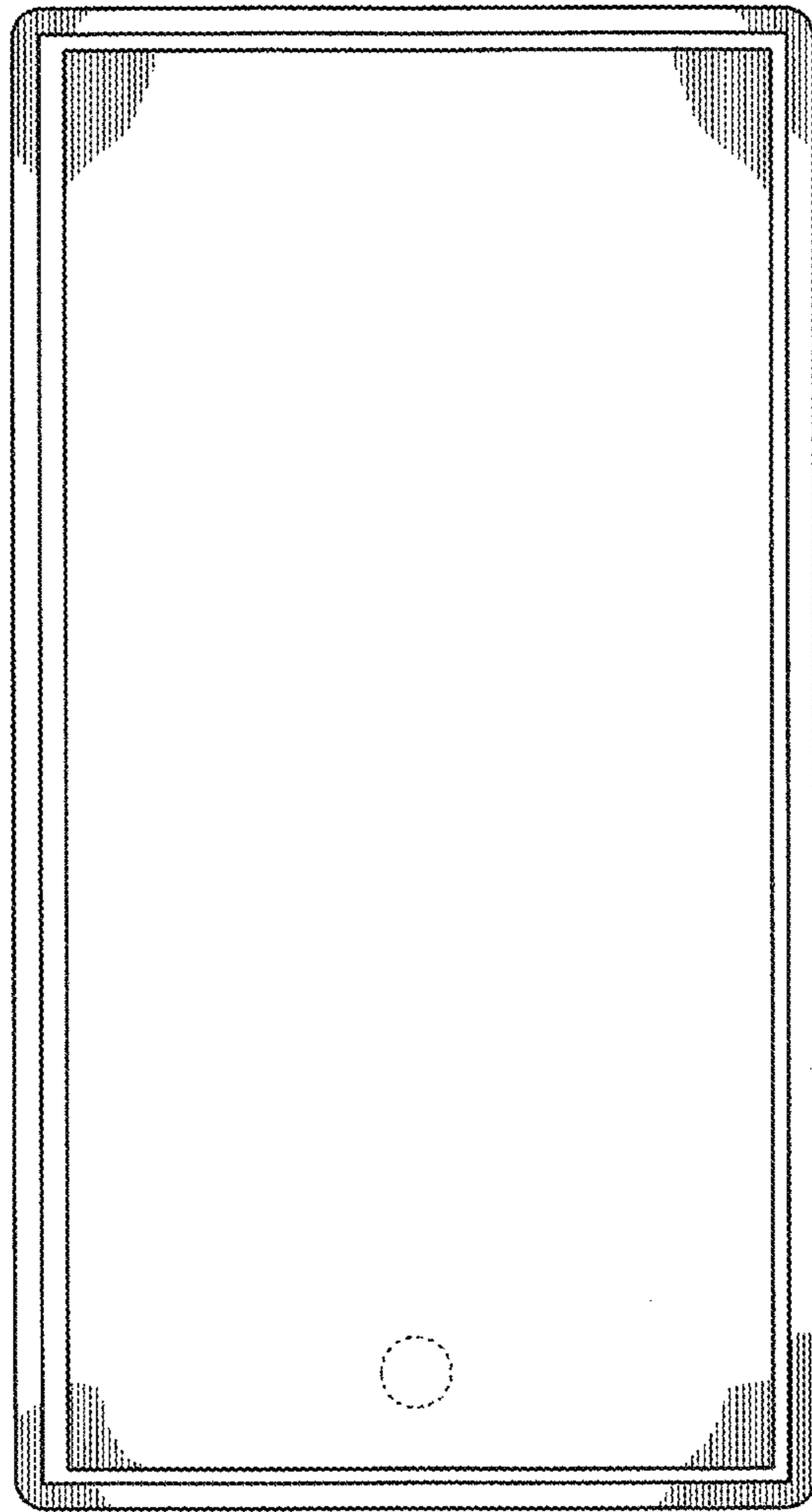
*Fig. 9*



*Fig. 10*



*Fig. 11*



*Fig. 12*