



US00D785081S

(12) **United States Design Patent** (10) **Patent No.:** **US D785,081 S**
Lee (45) **Date of Patent:** **** Apr. 25, 2017**

(54) **BRIDGE OF A GUITAR**

FOREIGN PATENT DOCUMENTS

(71) Applicant: **Gopherwood Co., Ltd.**, Yangju-si;
Gyeonggi-do (KR)

GB 2463748 A * 3/2010 G10D 3/04
SK WO 2004079713 A1 * 9/2004 G10D 3/04

(72) Inventor: **Kyu Hun Lee**, Seoul (KR)

OTHER PUBLICATIONS

(73) Assignee: **Gopherwood Co., Ltd.**, Yangju-si,
Gyeonggi-do (KR)

Gopherwood Guitar, G100, no post date, [online], [site visited on Sep. 19, 2016]. Available from Internet, <URL: <http://gopherwoodguitar.com/product/g100d.php>>.*

(**) Term: **15 Years**

Primary Examiner — Sheryl Lane

(21) Appl. No.: **29/550,939**

Assistant Examiner — Samantha Wood

(22) Filed: **Jan. 8, 2016**

(74) *Attorney, Agent, or Firm* — Novick, Kim & Lee, PLLC; Jae Youn Kim

(51) **LOC (10) Cl.** **17-03**

(57) **CLAIM**

(52) **U.S. Cl.**
USPC **D17/21**

I claim the ornamental design for a bridge of a guitar, as shown and described.

(58) **Field of Classification Search**
USPC D17/21, 4, 9, 12, 13, 14, 15, 16, 17, 18,
D17/19, 20, 22, 23, 24, 99; D21/405,
D21/586; D28/7; D10/18, 21, 24, 25,
D10/27, 28, 46, 93, 104.1, 106.1-2, 110,
D10/113.1-4, 114.1-9, 116.1; D6/582,
D6/583, 585, 596, 587, 601, 602, 603,
D6/606, 608, 610, 617
CPC .. G10D 3/00; G10D 3/04; G10D 3/02; G10D
3/003; G10D 3/146; G10D 3/043; H05K
7/20727; F24F 7/06; F24F 7/065; F04D
15/00

DESCRIPTION

See application file for complete search history.

FIG. 1 is a perspective view of a bridge of a guitar, showing my new design;
FIG. 2 is a front elevational view thereof;
FIG. 3 is a rear elevational view thereof;
FIG. 4 is a left side elevational view thereof;
FIG. 5 is a right side elevational view thereof;
FIG. 6 is a top plan view thereof;
FIG. 7 is a bottom plan view thereof;
FIG. 8 is an enlarged view of the bridge of a guitar shown in FIG. 1;
FIG. 9 is an enlarged view of the bridge of a guitar shown in FIG. 2;
FIG. 10 is an enlarged view of the bridge of a guitar shown in FIG. 4; and,
FIG. 11 is an enlarged view of the bridge of a guitar shown in FIG. 5.

(56) **References Cited**

U.S. PATENT DOCUMENTS

D222,110 S * 9/1971 Rendell 84/307
3,656,395 A * 4/1972 Kaman G10D 3/02
84/267
4,026,181 A * 5/1977 Barcus G10D 3/00
84/277
D256,804 S * 9/1980 Fender D17/21
D269,440 S * 6/1983 Fender D17/21

The dash-dash broken lines in the drawings represent the environment of the claimed design only and form no part thereof. The dot-dash broken lines in the drawings define the bounds of the claimed design and form no part thereof.

(Continued)

1 Claim, 8 Drawing Sheets

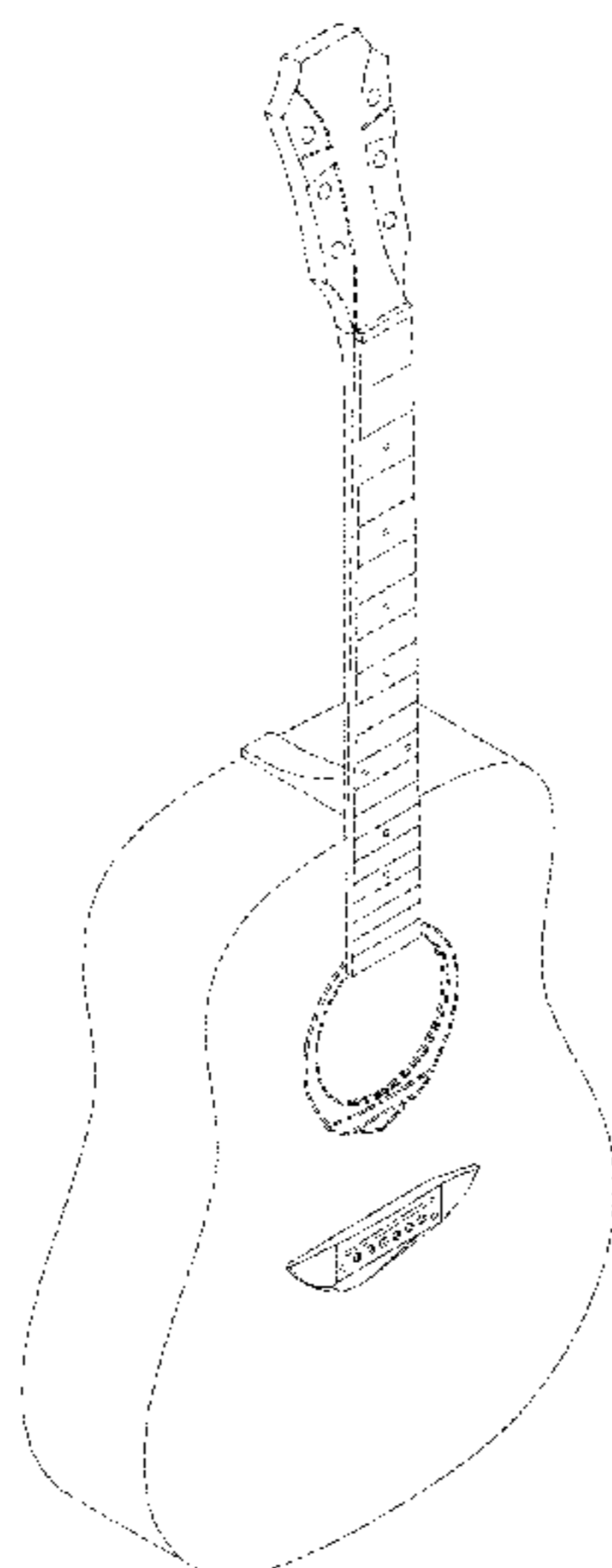

(56)

References Cited

U.S. PATENT DOCUMENTS

4,580,480 A * 4/1986 Turner G10H 3/185
84/723
D287,602 S * 1/1987 Smith D17/20
D400,564 S * 11/1998 Ferguson D17/21
D508,517 S * 8/2005 Park D17/21
7,301,086 B2 * 11/2007 Ito G10D 3/04
84/298
D566,166 S * 4/2008 DeMars D17/18
D631,101 S * 1/2011 Wasserman D17/12
8,633,364 B1 * 1/2014 Micheletti G10D 1/08
84/291
D764,572 S * 8/2016 Akers D17/21
2014/0083275 A1 * 3/2014 Martin G10D 3/12
84/307
2016/0163294 A1 * 6/2016 Martin G10D 1/08
84/267

* cited by examiner

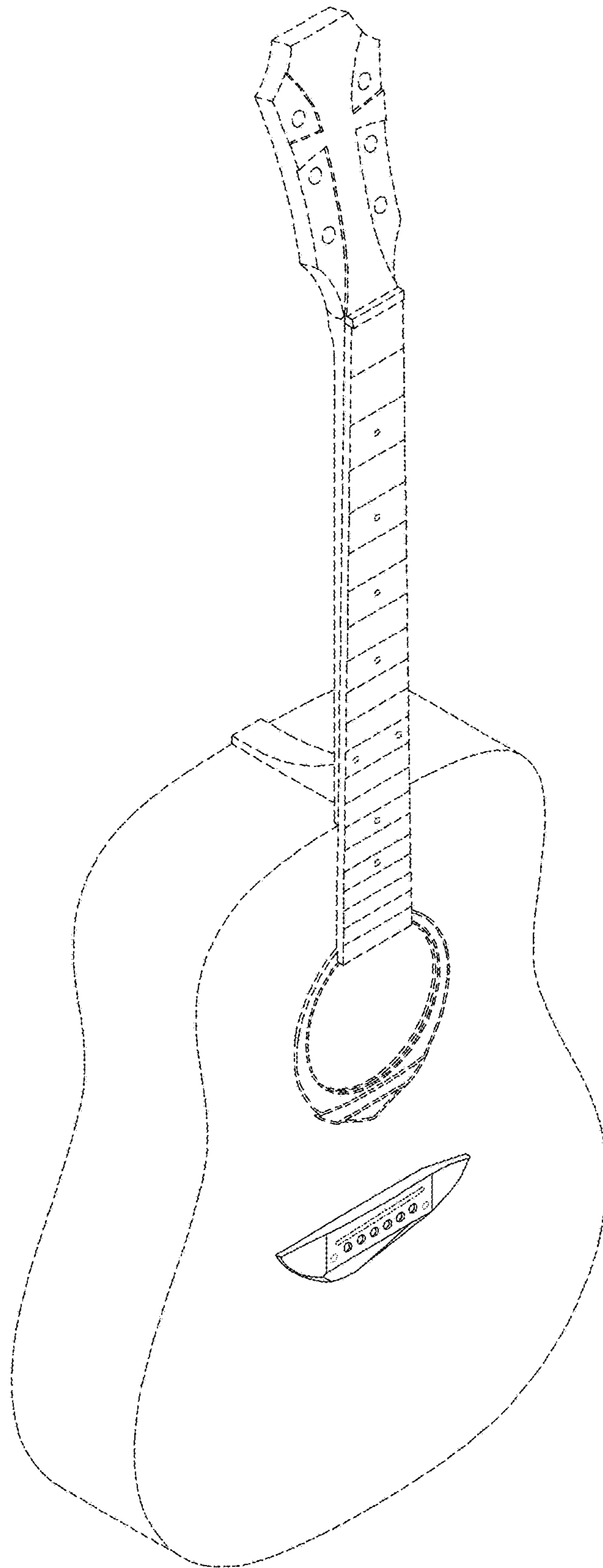

FIG. 1

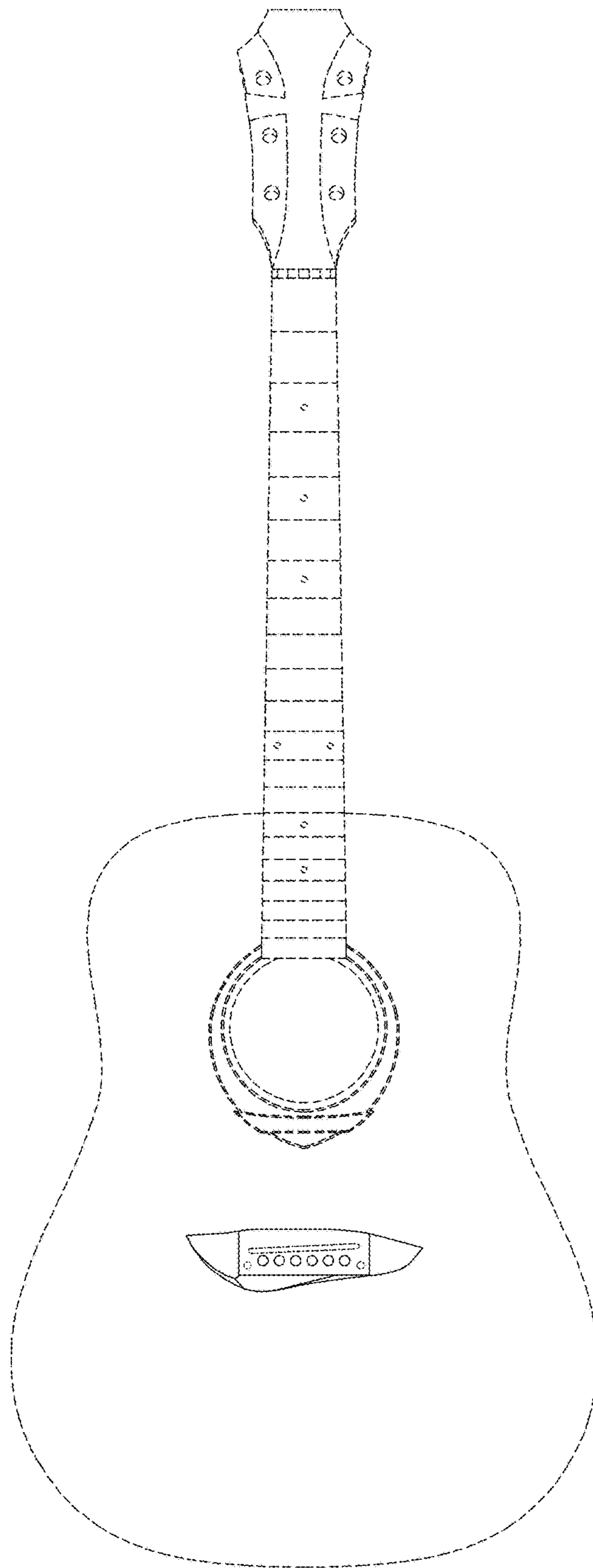

FIG. 2

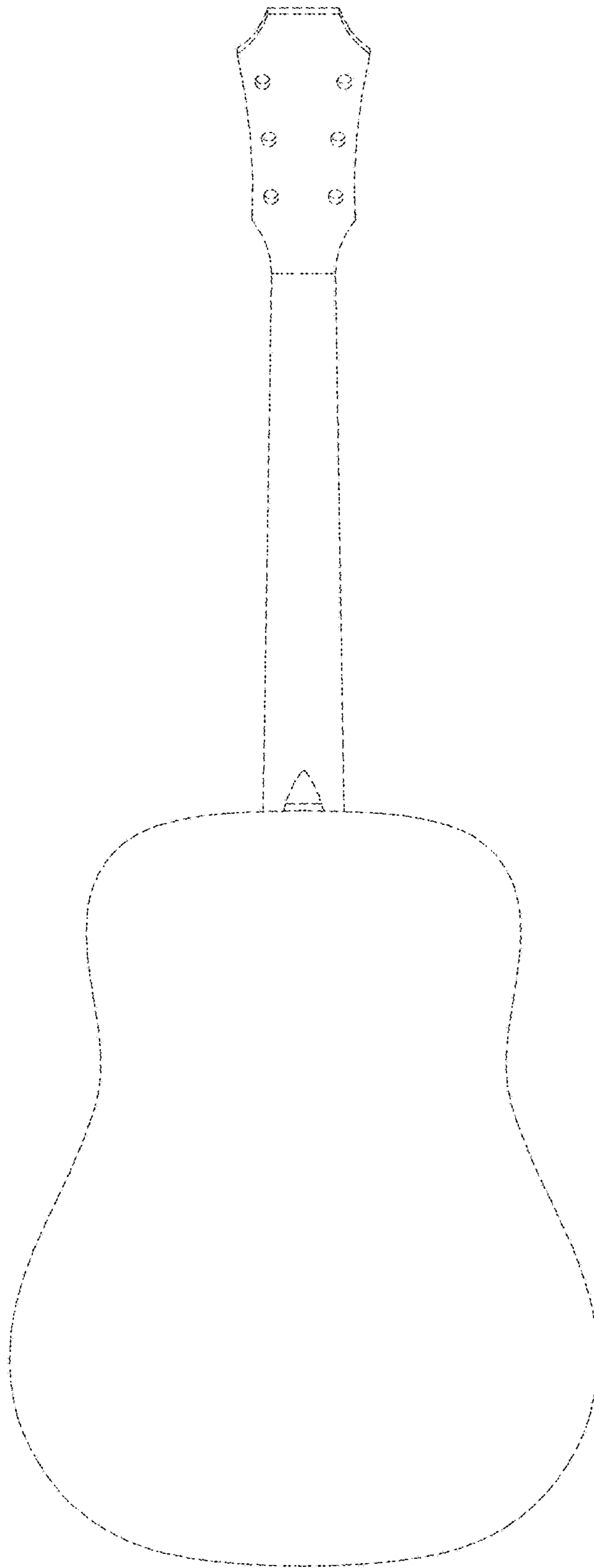

FIG. 3

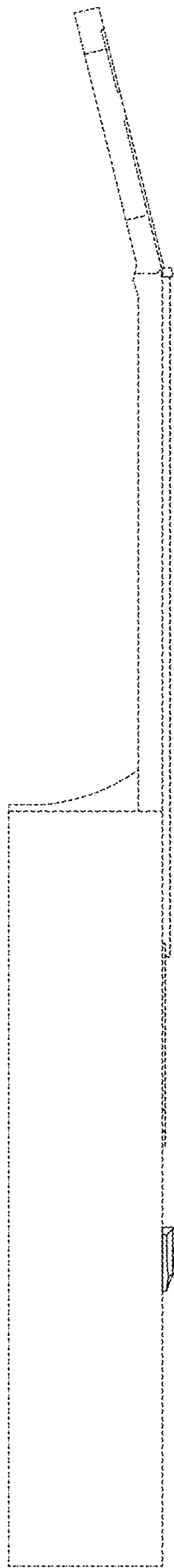

FIG. 4

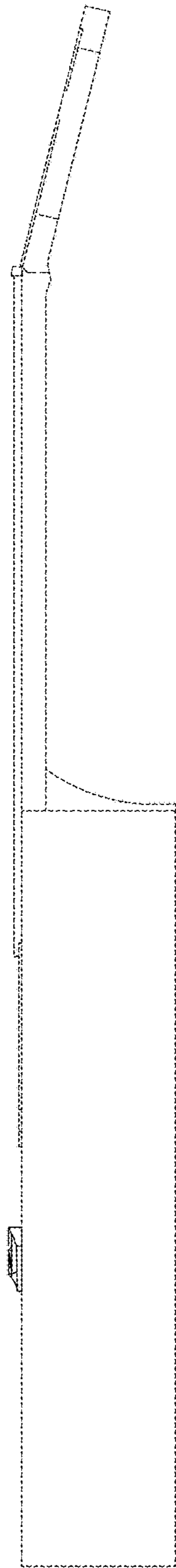

FIG. 5

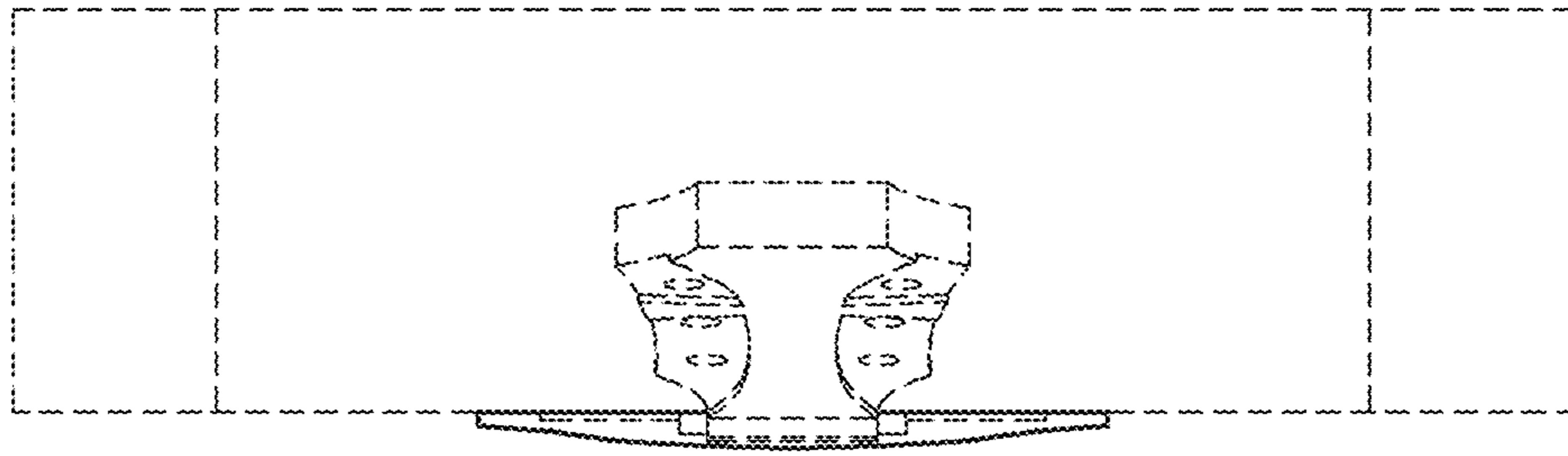

FIG. 6



FIG. 7

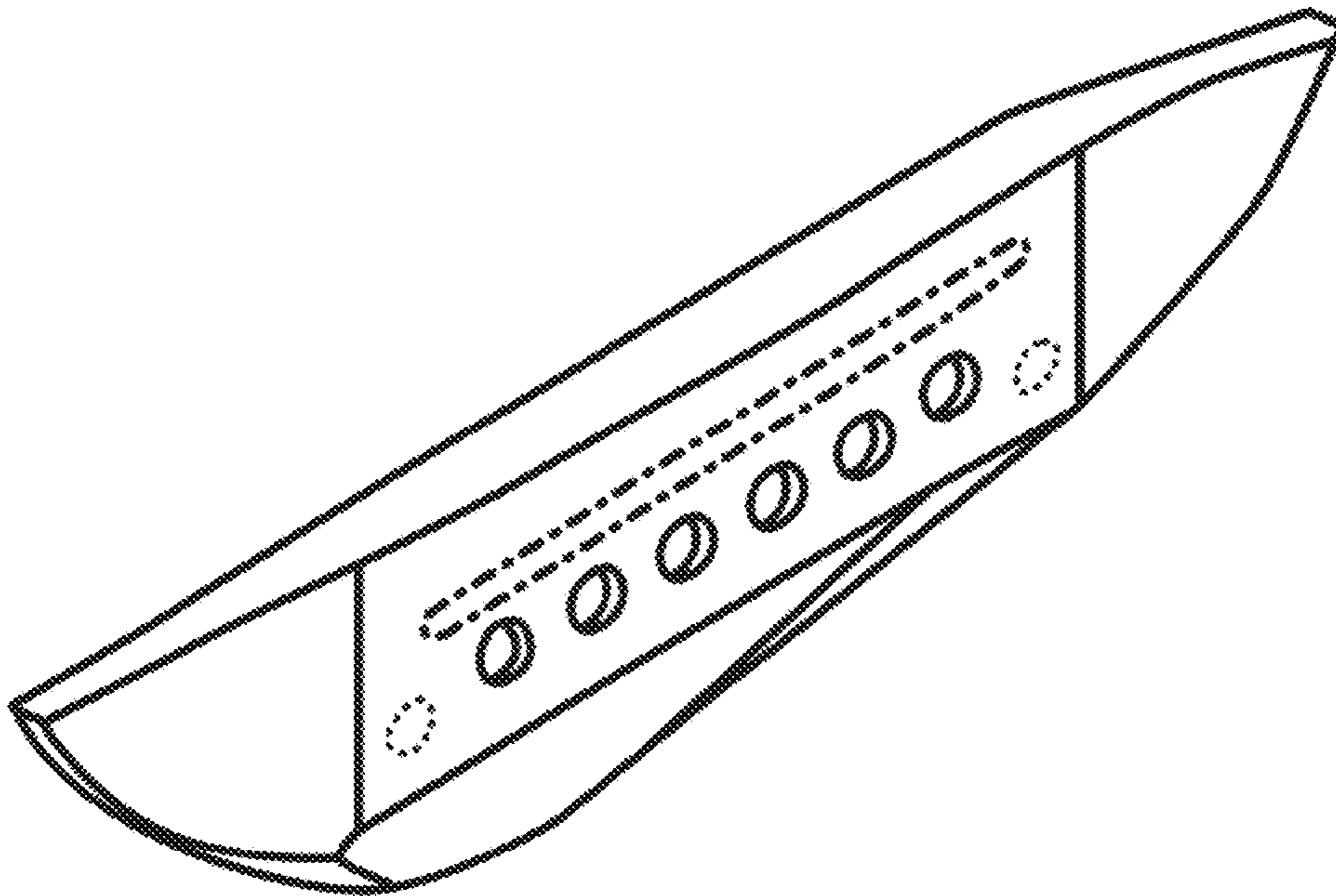

FIG. 8

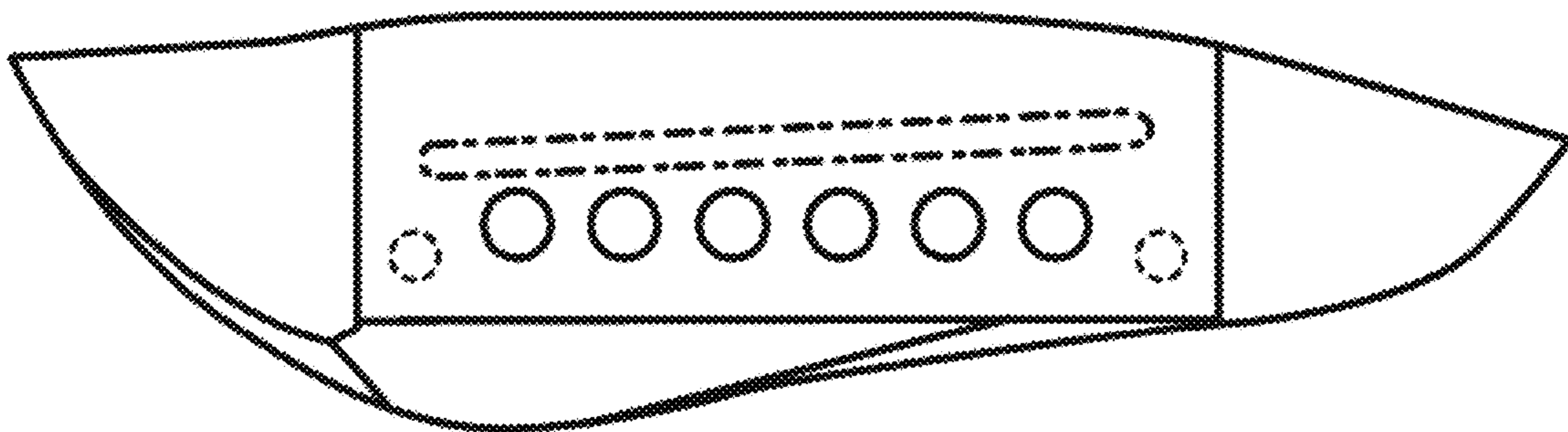

FIG. 9

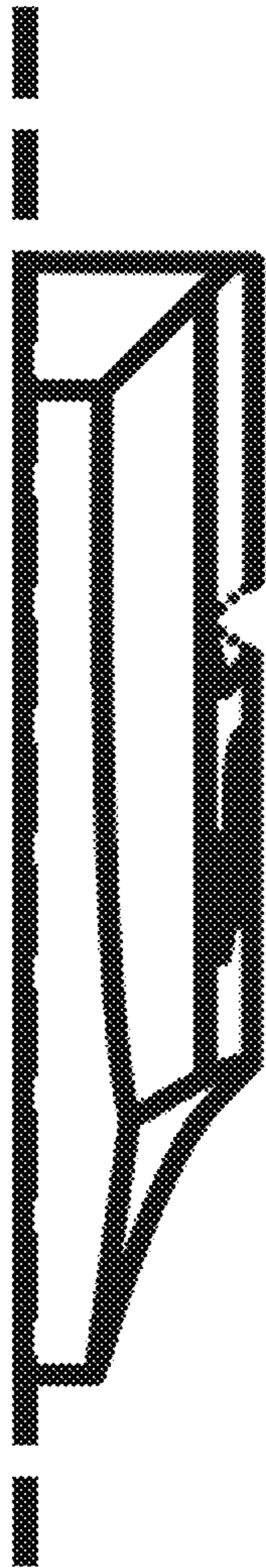

FIG. 10

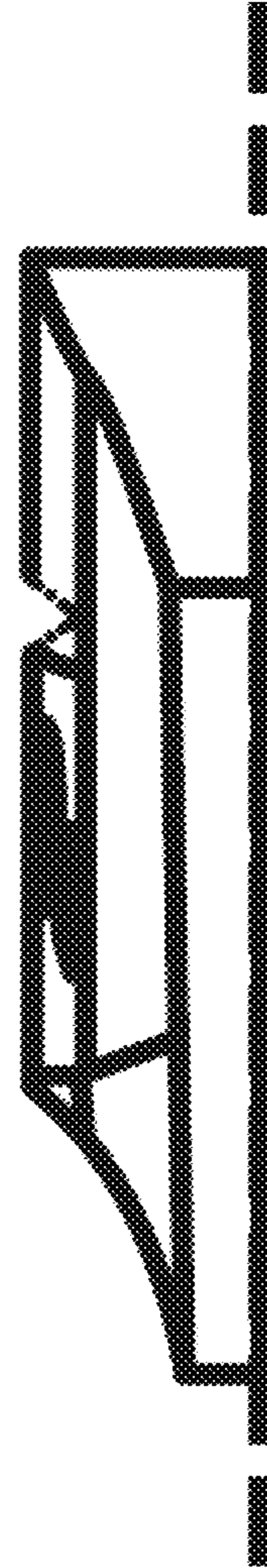

FIG. 11