



US00D784859S

(12) **United States Design Patent**
Matsumura

(10) **Patent No.:** **US D784,859 S**

(45) **Date of Patent:** **** Apr. 25, 2017**

(54) **HANDLE SWITCH FOR MOTORCYCLES**

(71) Applicant: **Kawasaki Jukogyo Kabushiki Kaisha,**
Hyogo (JP)

(72) Inventor: **Norikazu Matsumura,** Akashi (JP)

(73) Assignee: **KAWASAKI JUKOGYO**
KABUSHIKI KAISHA, Hyogo (JP)

(**) Term: **14 Years**

(21) Appl. No.: **29/474,850**

(22) Filed: **Feb. 26, 2015**

(30) **Foreign Application Priority Data**

Aug. 29, 2014 (JP) 2014-019127

(51) **LOC (10) Cl.** **12-11**

(52) **U.S. Cl.**
USPC **D12/114**

(58) **Field of Classification Search**
USPC D12/114, 107, 174, 178
CPC ... B62K 11/14; B62K 23/02; H01H 2009/068
See application file for complete search history.

(56) **References Cited**

U.S. PATENT DOCUMENTS

D265,816 S *	8/1982	Matre	D12/114
4,641,723 A *	2/1987	Takanashi	B62K 11/14 180/219
D534,843 S *	1/2007	Higashi	D12/174
D556,645 S *	12/2007	Madden	D12/126
D575,203 S *	8/2008	Madden	D12/126
D591,652 S *	5/2009	Reed	D12/174
D599,262 S *	9/2009	Reed	D12/174
D619,944 S *	7/2010	Shimizugami	D12/179
D729,710 S *	5/2015	Iwata	D12/174

2007/0051552 A1 *	3/2007	Reed	B62K 11/14 180/333
2011/0108397 A1 *	5/2011	Kodaira	B62K 11/14 200/61.54
2013/0140154 A1 *	6/2013	Tozuka	H01H 9/06 200/61.54
2014/0284187 A1 *	9/2014	Kikuchi	B62K 11/14 200/61.85

* cited by examiner

Primary Examiner — George D. Kirschbaum
Assistant Examiner — Clese Moore, Jr.

(57) **CLAIM**

The ornamental design for a handle switch for motorcycles, as shown and described.

DESCRIPTION

FIG. 1 is a front elevational view of a handle switch for motorcycles showing my new design; FIG. 2 is a rear elevational view thereof; FIG. 3 is a left side elevational view thereof; FIG. 4 is a right side elevational view thereof; FIG. 5 is a top plan view thereof; FIG. 6 is a bottom plan view thereof; FIG. 7 is a front right perspective view thereof; and, FIG. 8 is a rear left perspective view thereof. The dark and light grayed surfaces shown on the surface of the design drawings do not represent a color nor a design pattern and only represent shading features on the surface of the ornamental design. The broken lines in the design drawings depict unclaimed subject matter. The unshaded surfaces bounded by broken lines form no part of the claimed design.

1 Claim, 8 Drawing Sheets

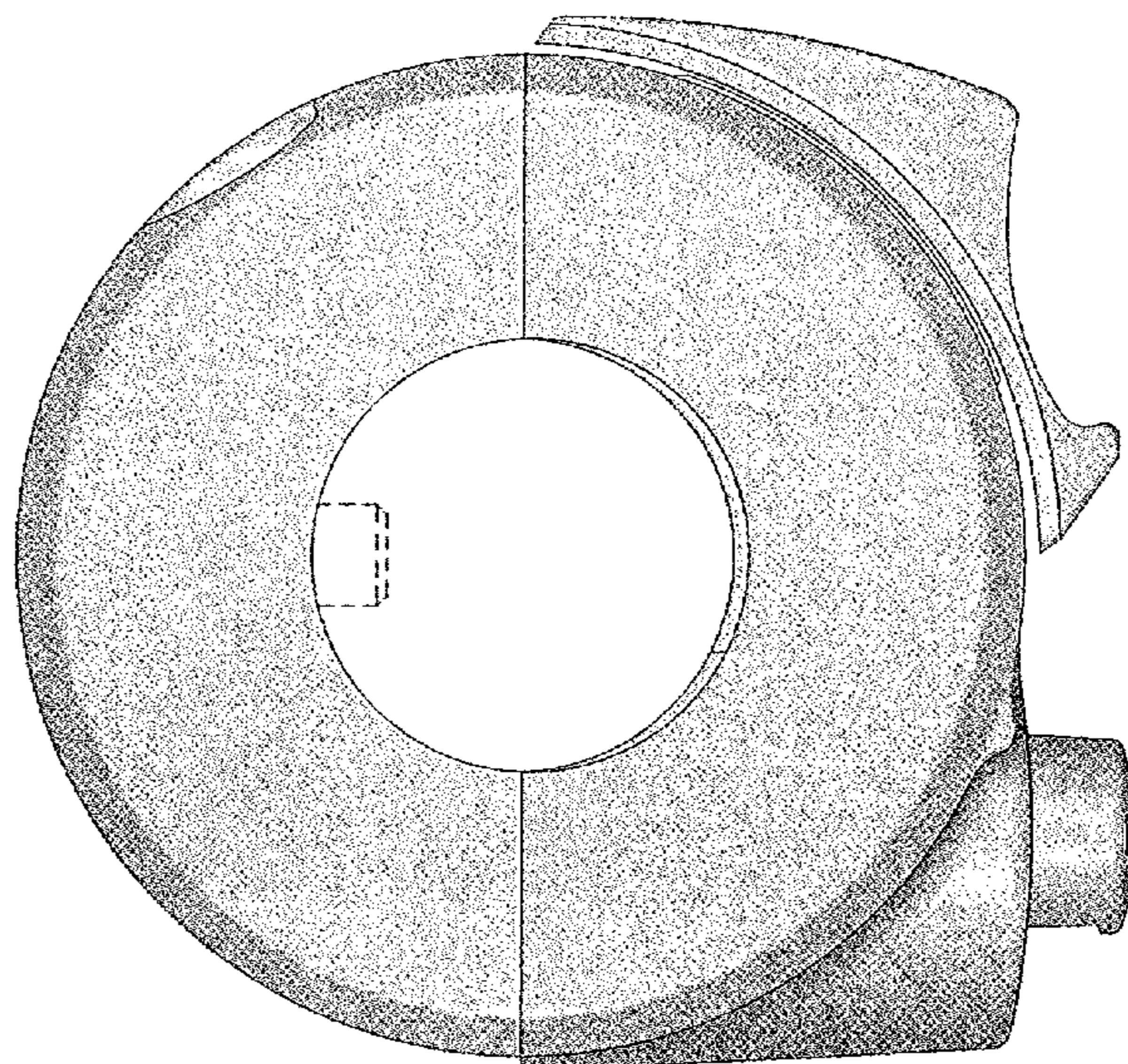

Fig. 1

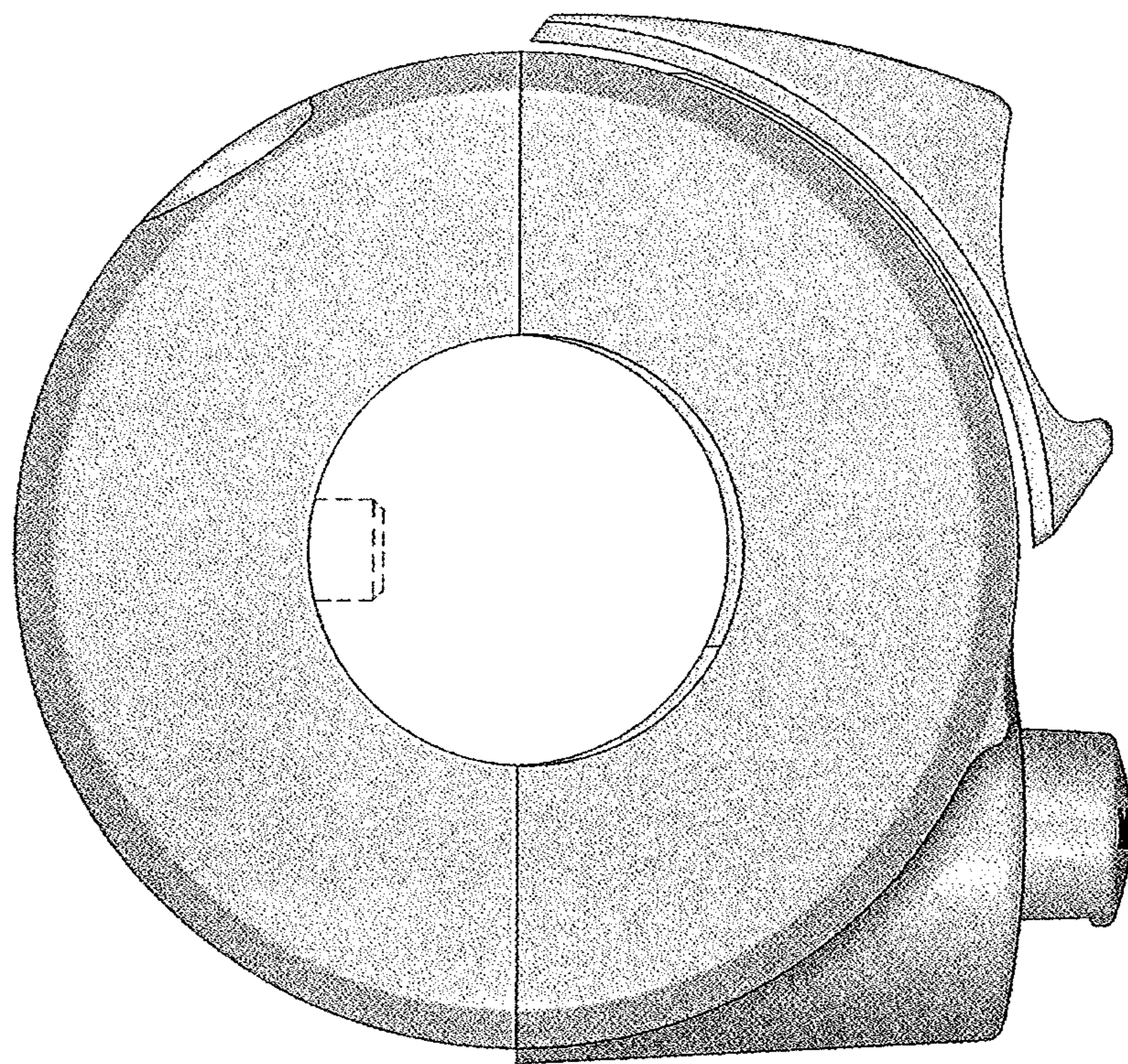

Fig. 2

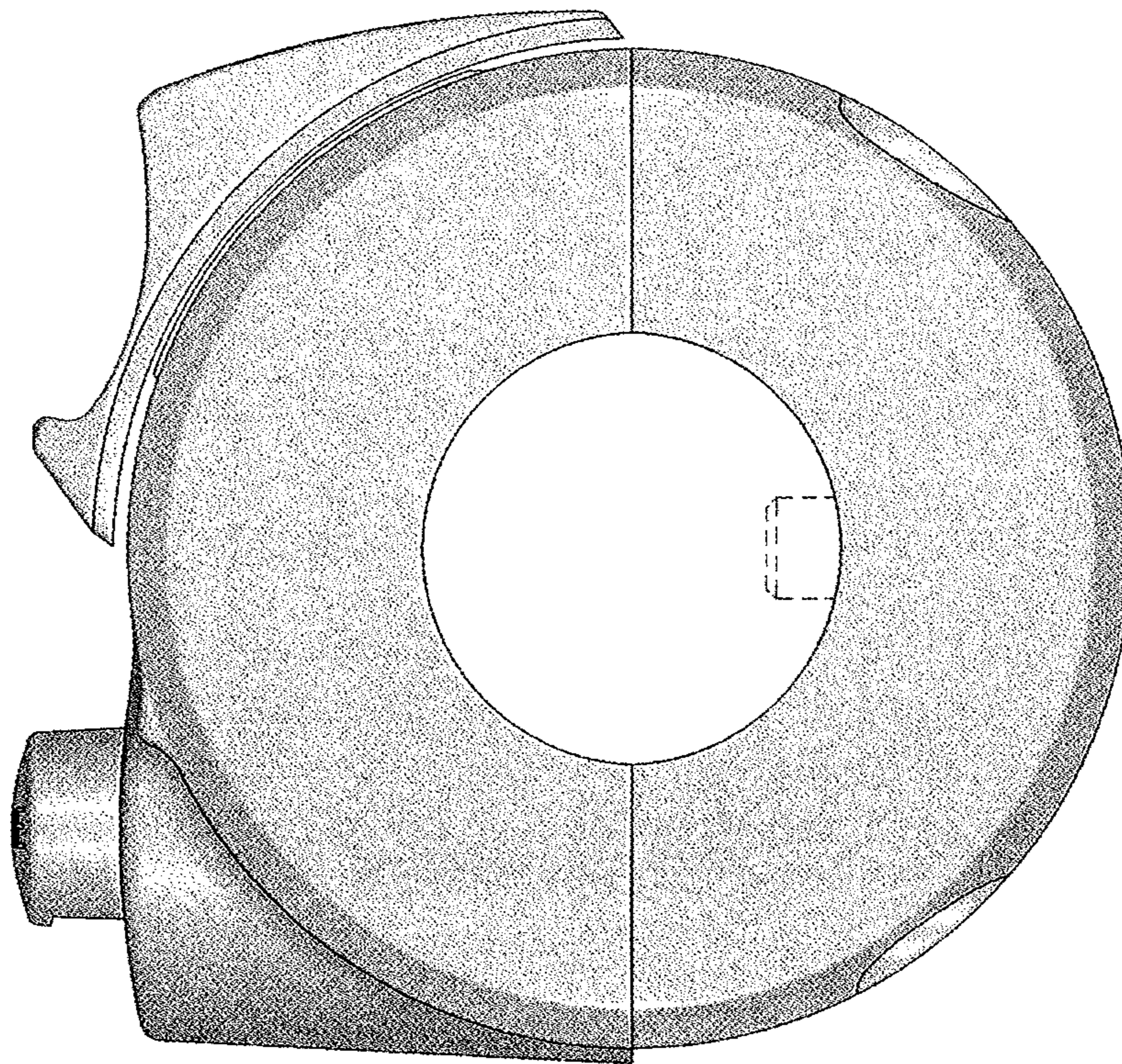

Fig. 3

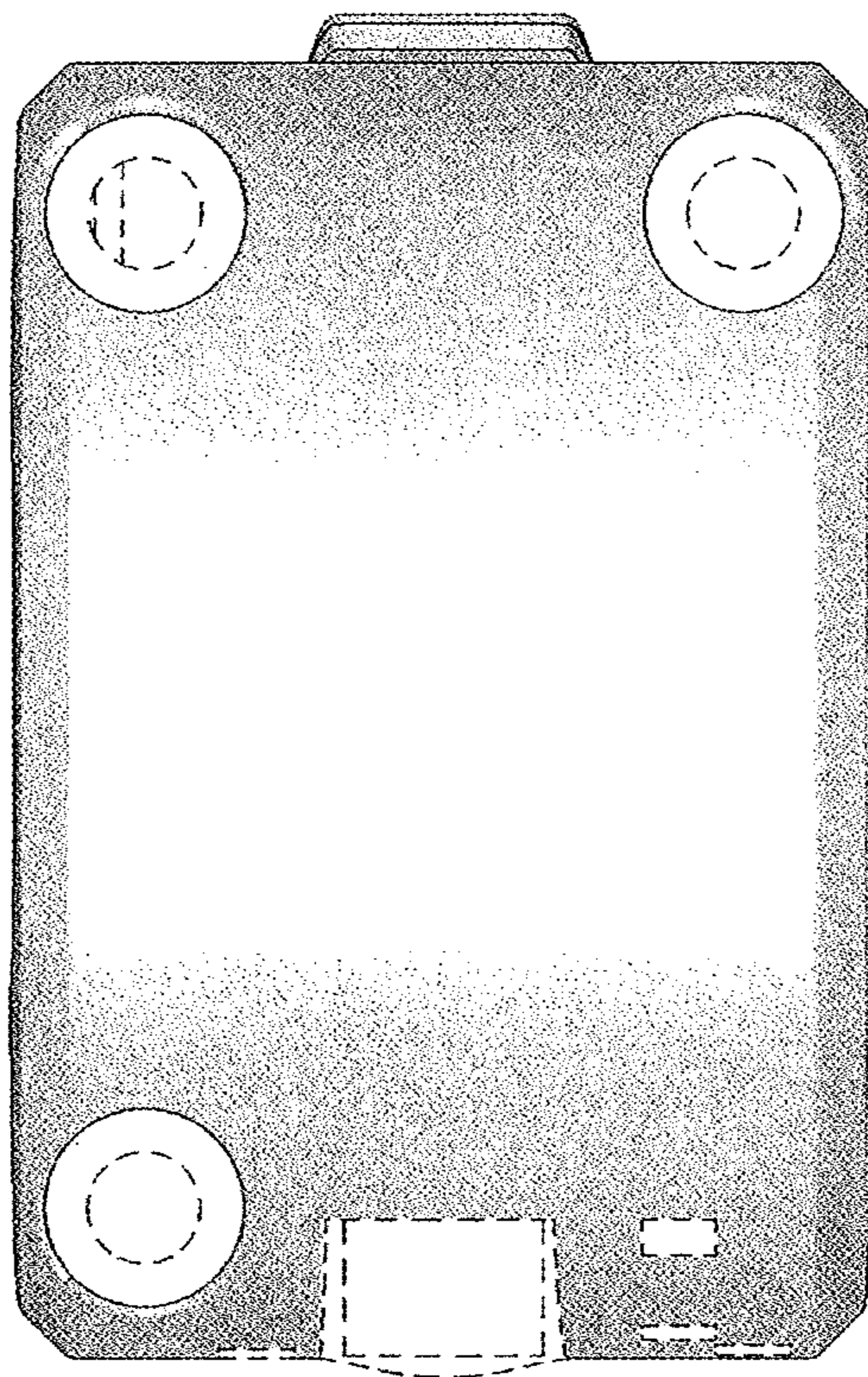

Fig. 4

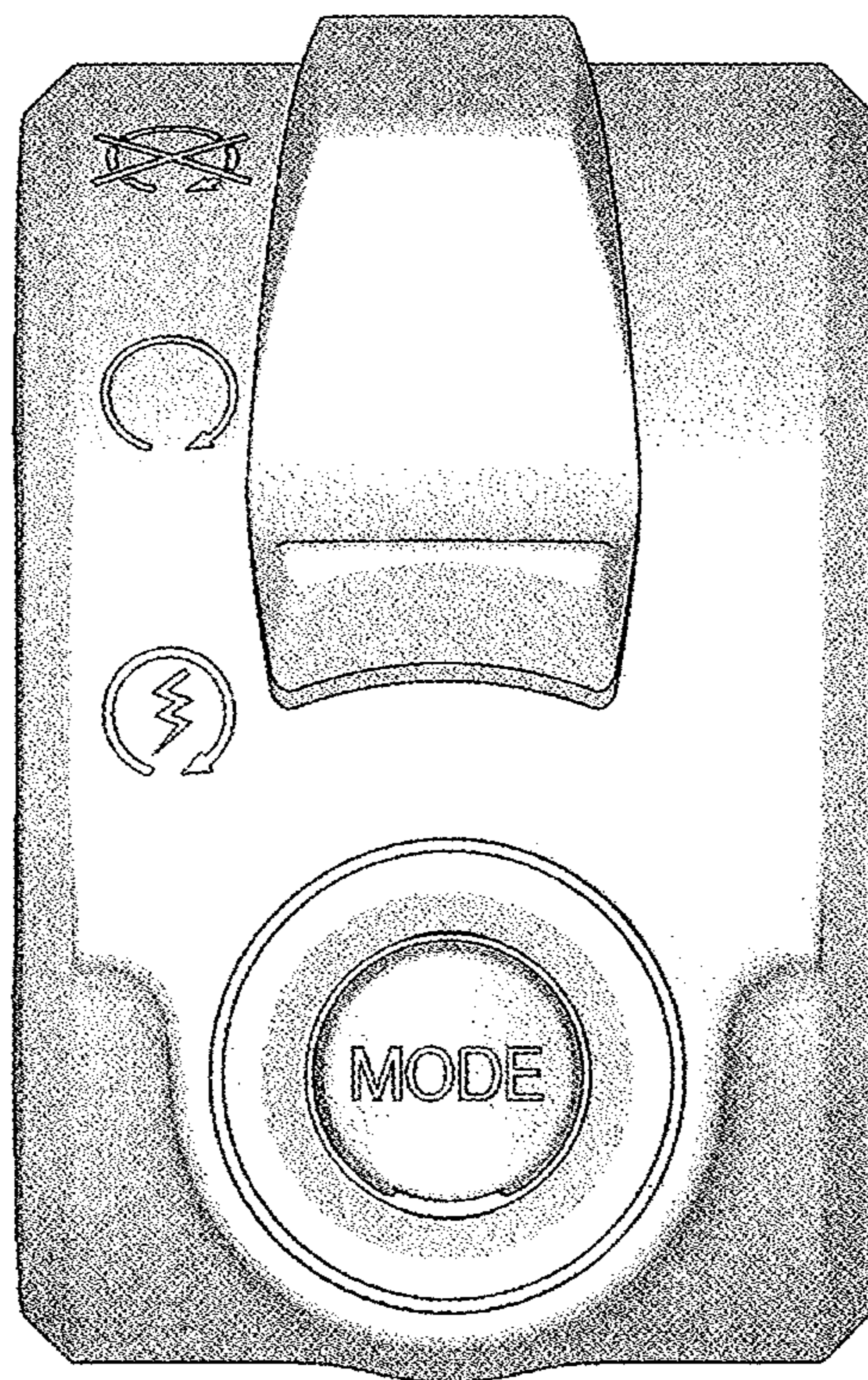

Fig. 5

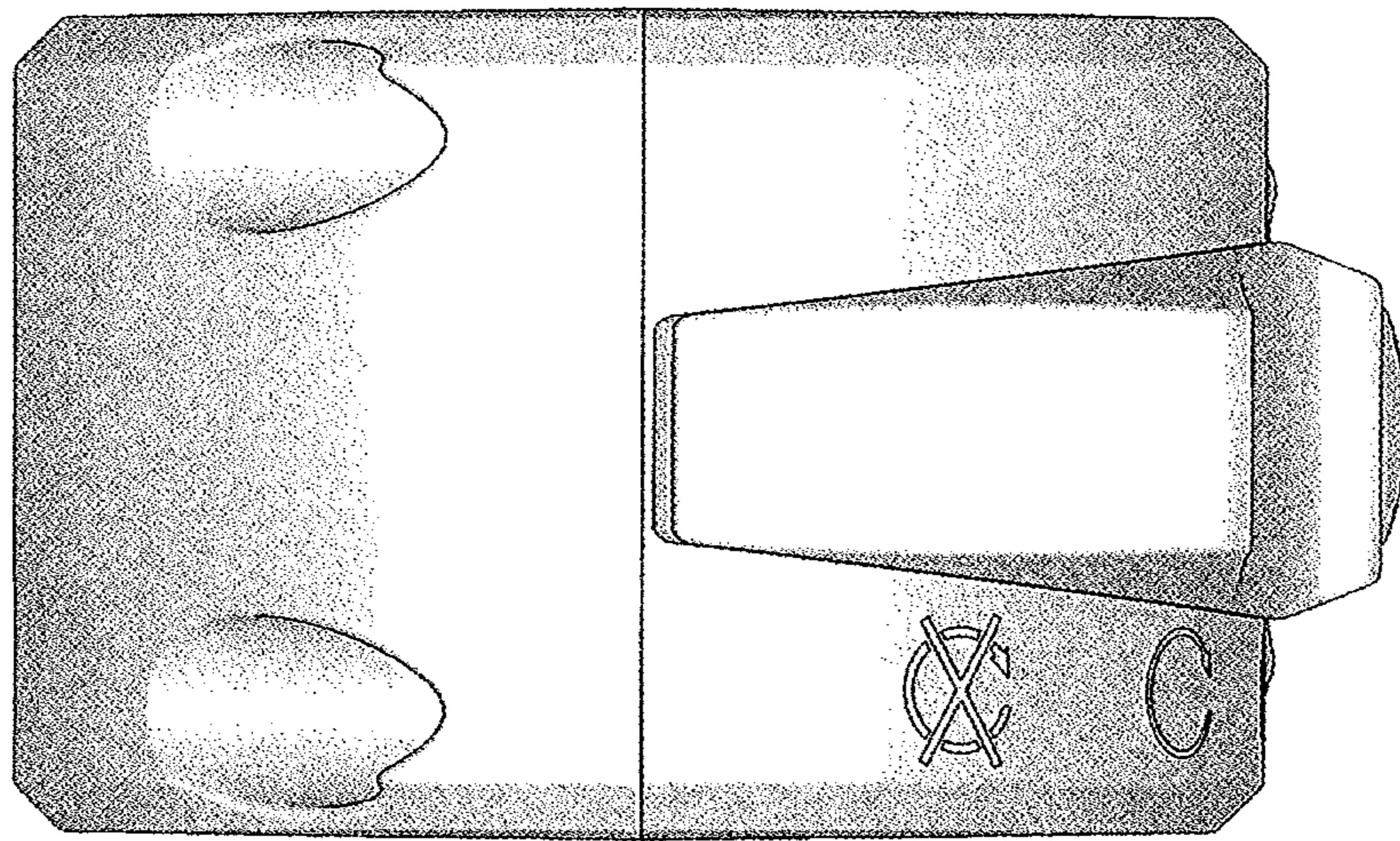

Fig. 6

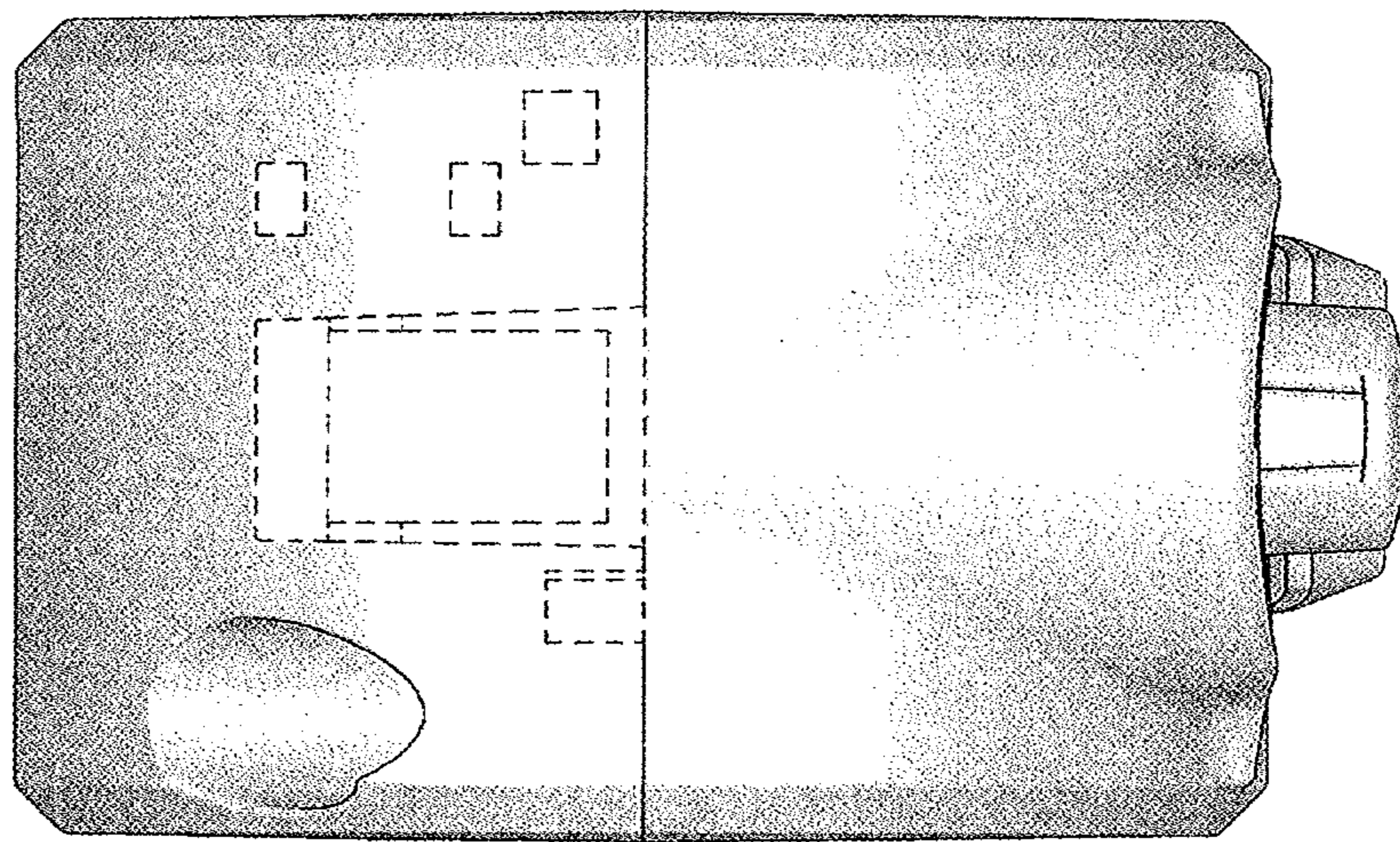

Fig. 7

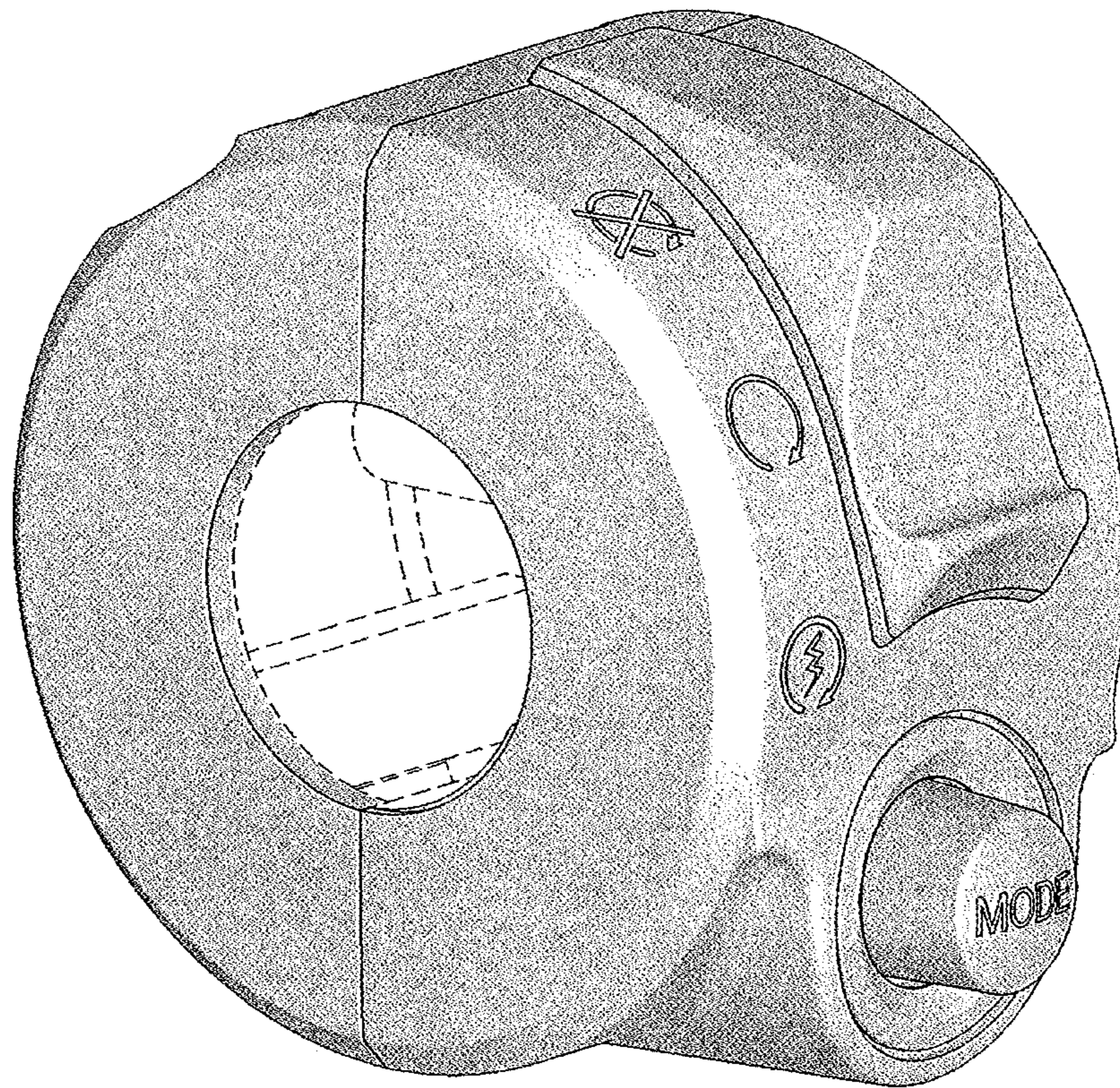

Fig. 8

