



US00D784652S

(12) **United States Design Patent**  
**Green**

(10) **Patent No.:** **US D784,652 S**

(45) **Date of Patent:** **\*\* Apr. 25, 2017**

(54) **MOUNTABLE BOOT JACK**

7,048,159 B1 \* 5/2006 Bowers ..... A47G 25/80  
223/115

(71) Applicant: **Parish Orville Green**, Bakersfield, CA  
(US)

\* cited by examiner

*Primary Examiner* — Celia Murphy

*Assistant Examiner* — Clare Ann Gannon

(72) Inventor: **Parish Orville Green**, Bakersfield, CA  
(US)

(74) *Attorney, Agent, or Firm* — Richard A. Ryan

(\*\*) Term: **15 Years**

(57) **CLAIM**

The ornamental design for a mountable boot jack, as shown and described.

(21) Appl. No.: **29/535,920**

**DESCRIPTION**

(22) Filed: **Aug. 11, 2015**

(51) **LOC (10) Cl.** ..... **07-99**

(52) **U.S. Cl.**  
USPC ..... **D2/642**

(58) **Field of Classification Search**

USPC ..... D2/641–643; D6/686; D20/33; D32/59;  
D12/119; D11/221

CPC ..... A44B 99/005; A47G 25/80; A47G 25/82;  
A47G 25/84; A47G 25/845; A47G 25/86;  
A47G 25/904; A47G 25/907; A47G  
25/92; A47F 8/00; A61G 7/1019; A61G  
2200/36; A61G 2200/52

See application file for complete search history.

FIG. 1 is a left front perspective view of the design for a mountable boot jack;

FIG. 2 is a top view of the mountable boot jack;

FIG. 3 is a bottom view of the mountable boot jack;

FIG. 4 is a front view of the mountable boot jack;

FIG. 5 is a back view of the mountable boot jack;

FIG. 6 is a right side view of the mountable boot jack, the left side view being a mirror image thereof;

FIG. 7 is a left front perspective view of the mountable boot jack of FIG. 1 shown attached to a wall with a boot received therein, with the mountable boot jack shown in a smaller size to better illustrate the use thereof;

FIG. 8 is a left front perspective view of an alternative embodiment of the mountable boot jack of the present invention;

FIG. 9 is a right side view of the mountable boot jack of FIG. 8, the left side view being a mirror image thereof and the front and back view being the same as FIG. 4 and FIG. 5, respectively;

FIG. 10 is a top view of the mountable boot jack of FIG. 8; and,

FIG. 11 is a bottom view of the mountable boot jack of FIG. 8.

The broken lines in FIG. 7 depict environmental subject matter only and form no part of the claimed design.

(56) **References Cited**

**U.S. PATENT DOCUMENTS**

- 1,849,282 A \* 3/1932 Churchill ..... A47G 25/80  
223/115
- 3,734,364 A \* 5/1973 Mayer ..... A47G 25/80  
223/116
- D277,997 S \* 3/1985 Horner ..... D2/642
- D287,542 S \* 1/1987 Wilkinson ..... D2/642
- D320,691 S \* 10/1991 Rose ..... 223/115
- D350,011 S \* 8/1994 Edwards ..... D2/642

**1 Claim, 9 Drawing Sheets**

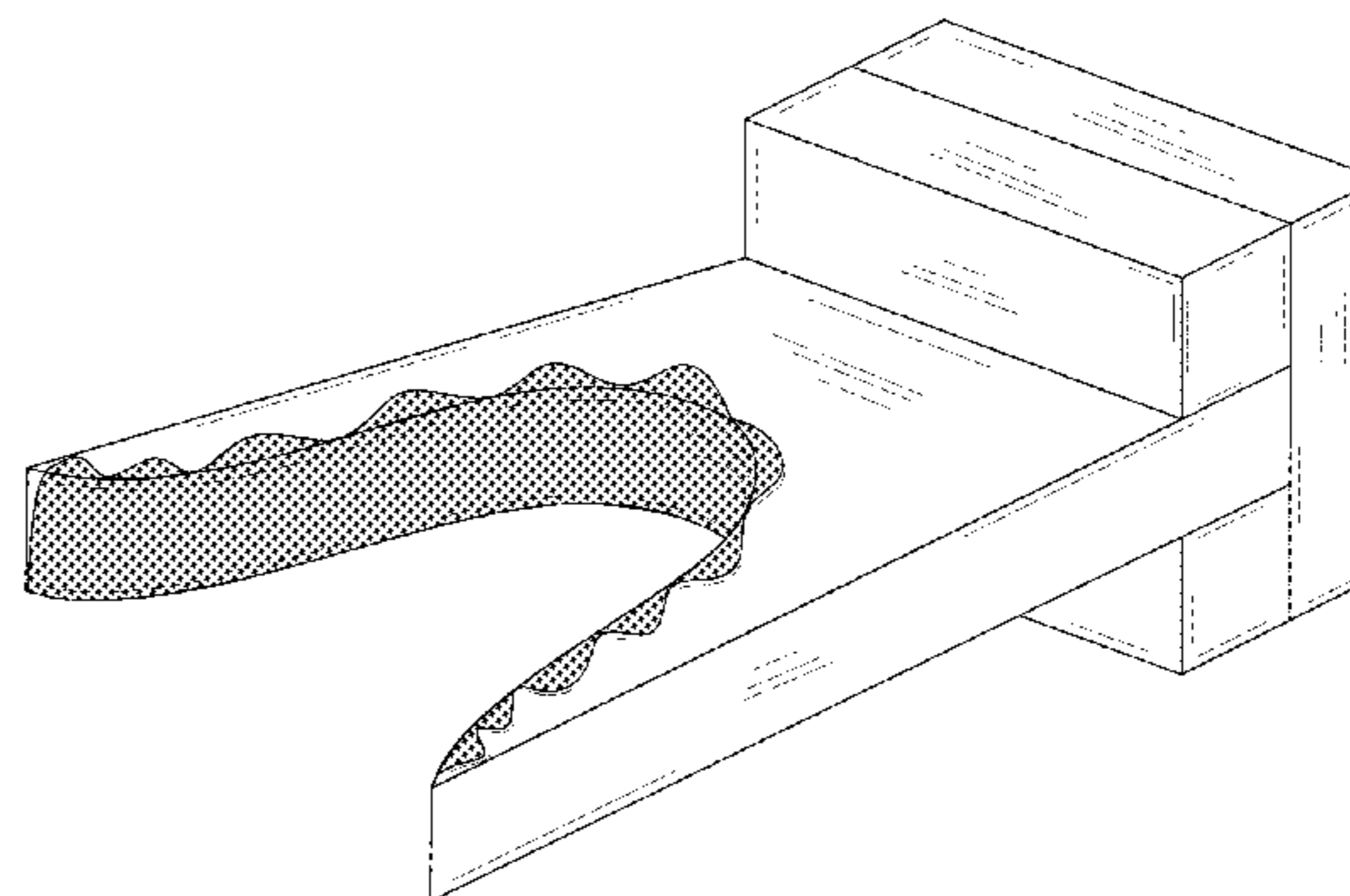
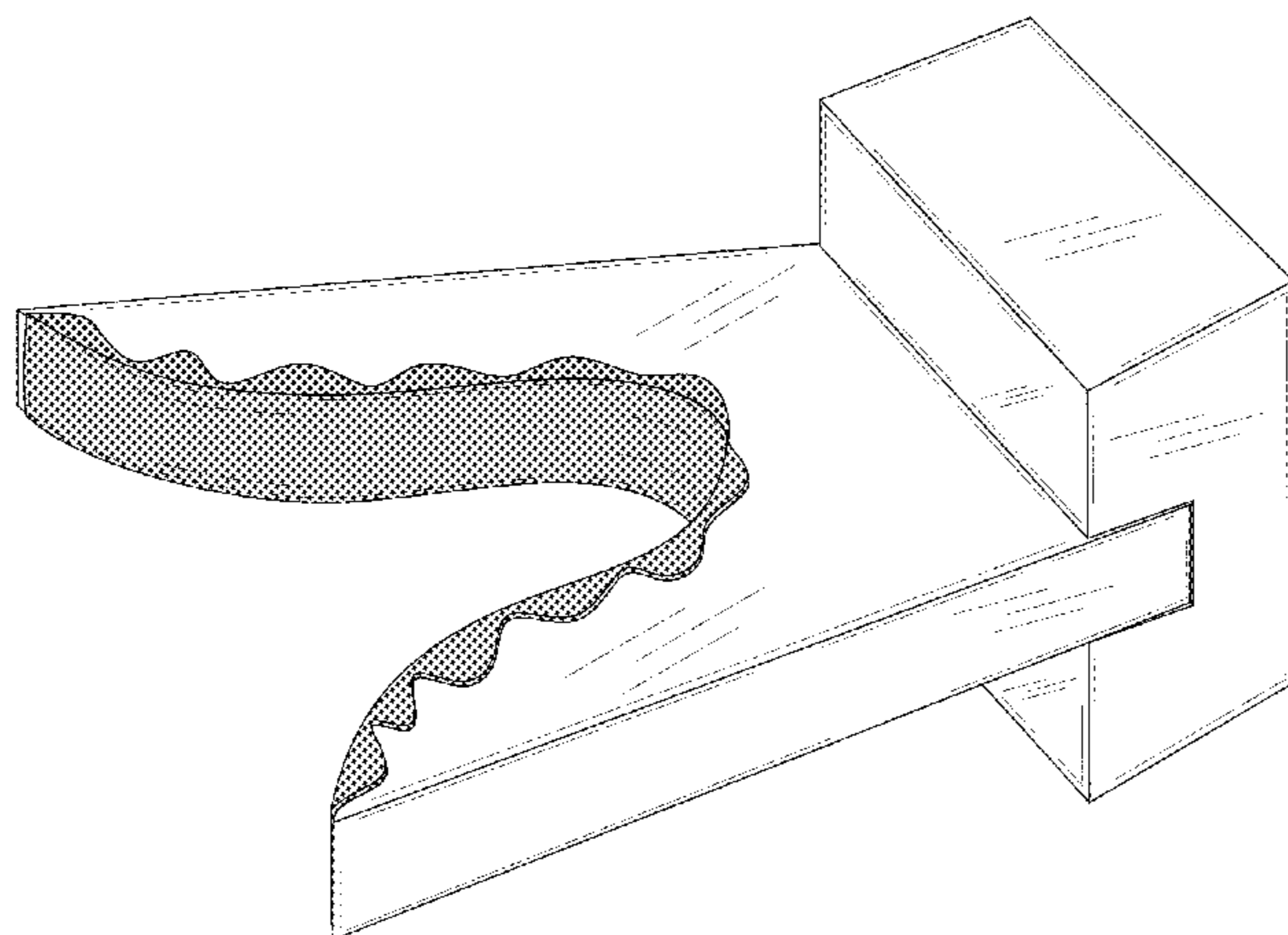

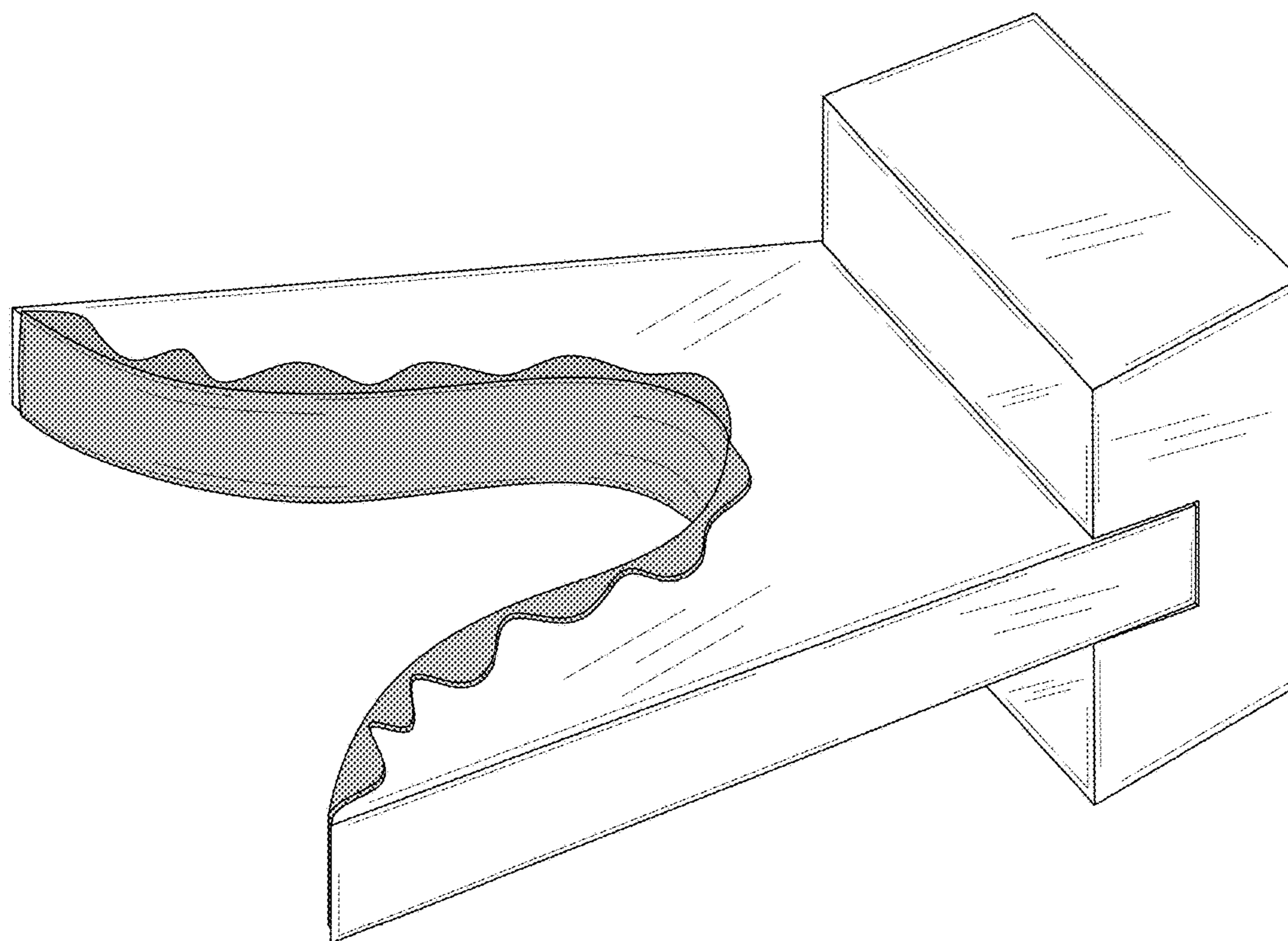
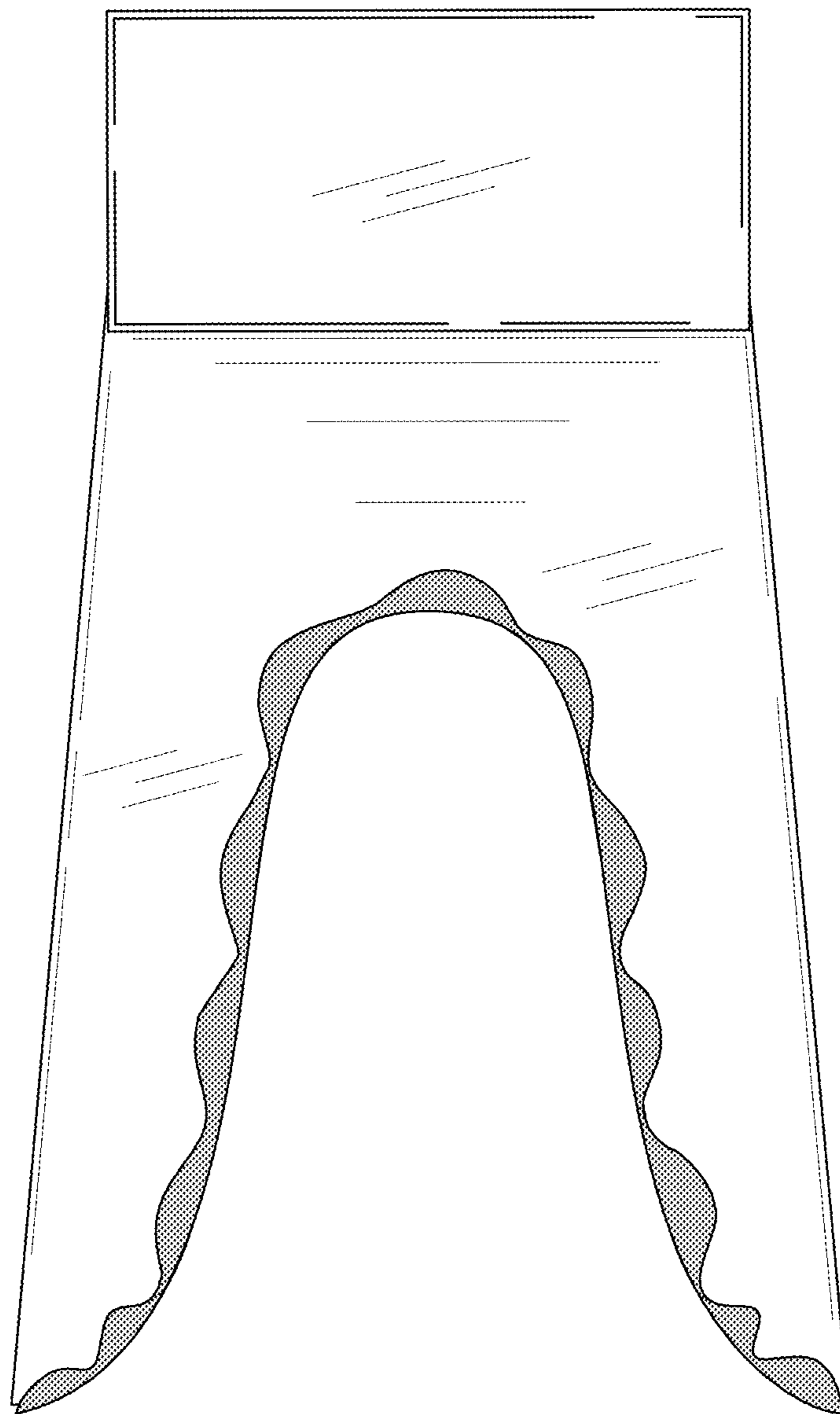
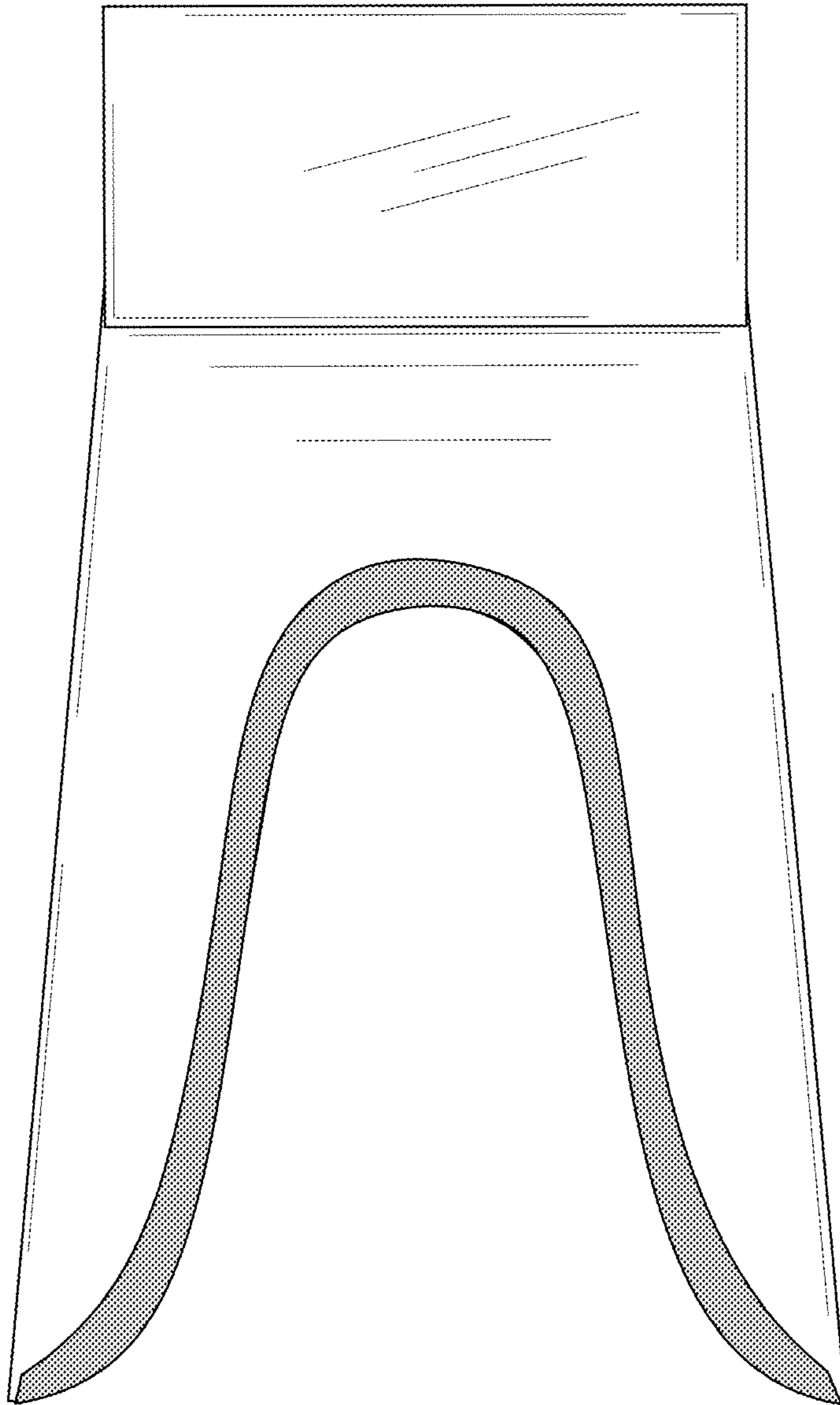

FIG. 1



**FIG. 2**



**FIG. 3**

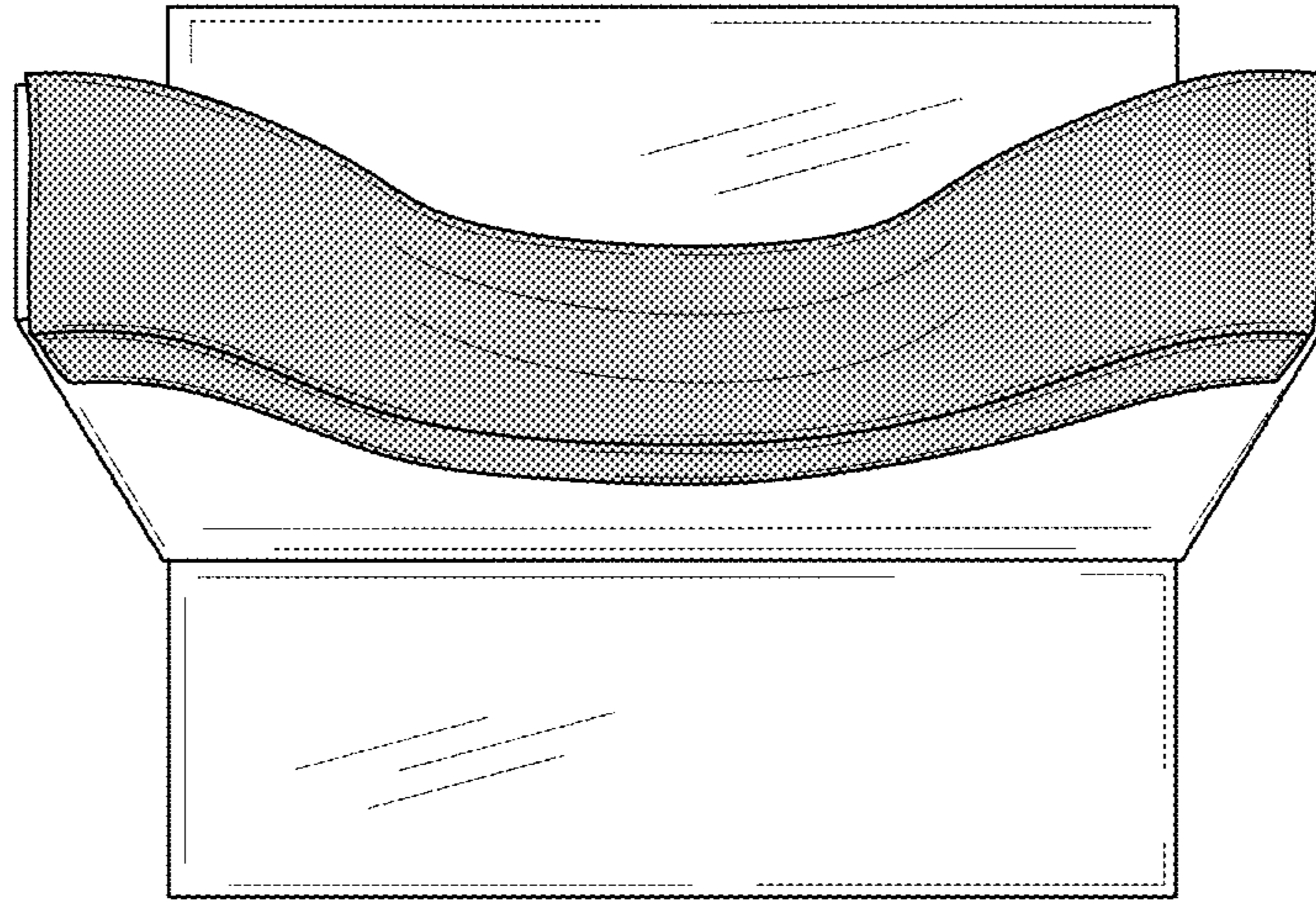

**FIG. 4**

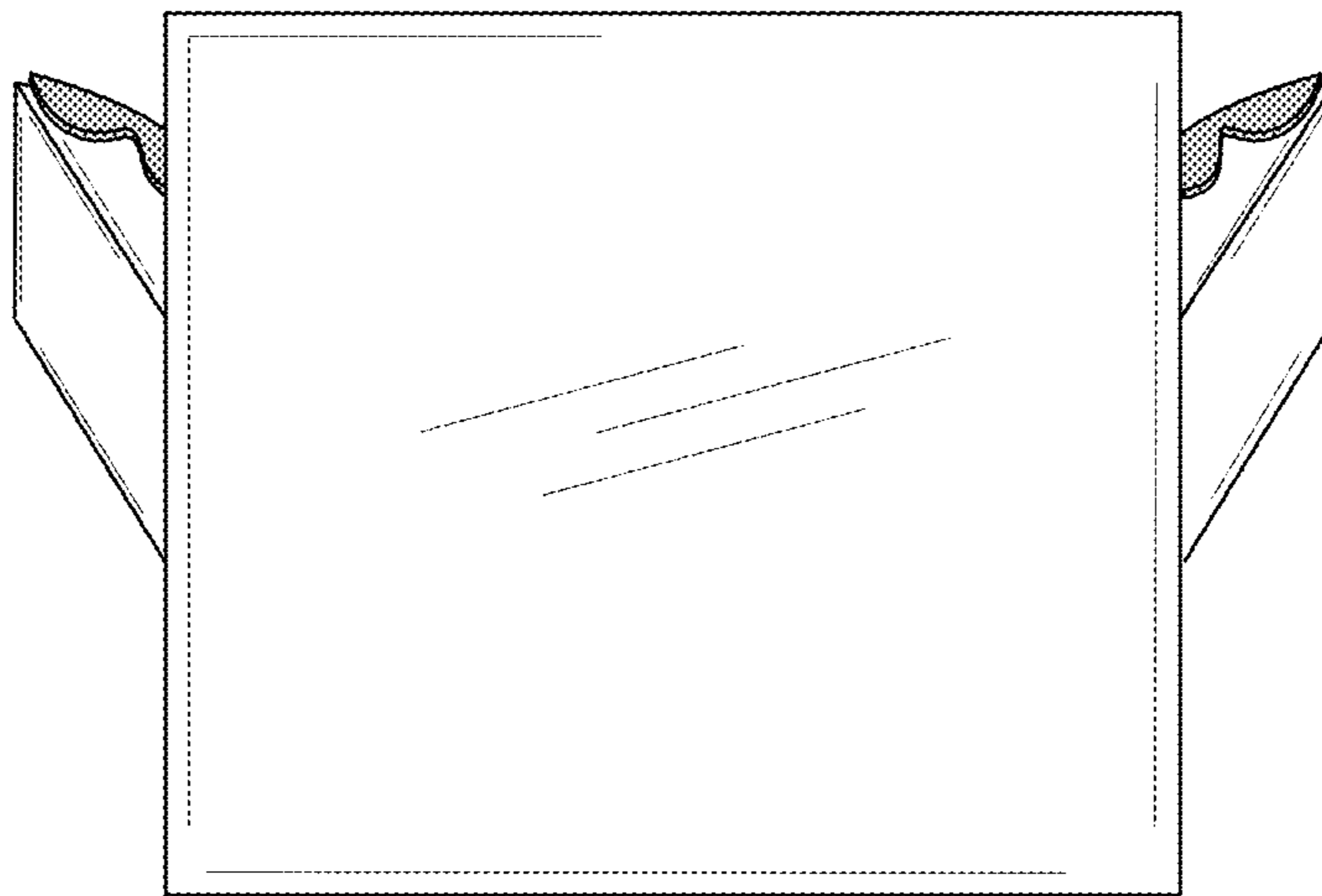

**FIG. 5**

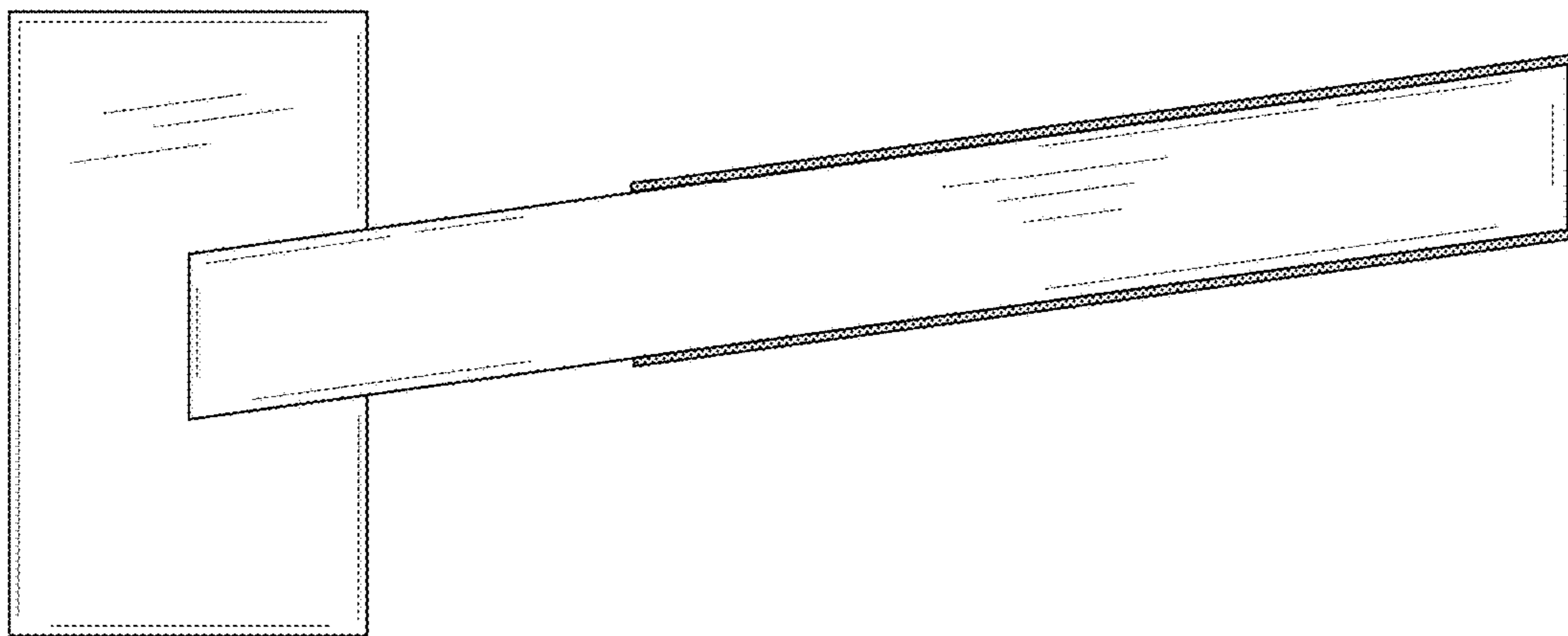

**FIG. 6**

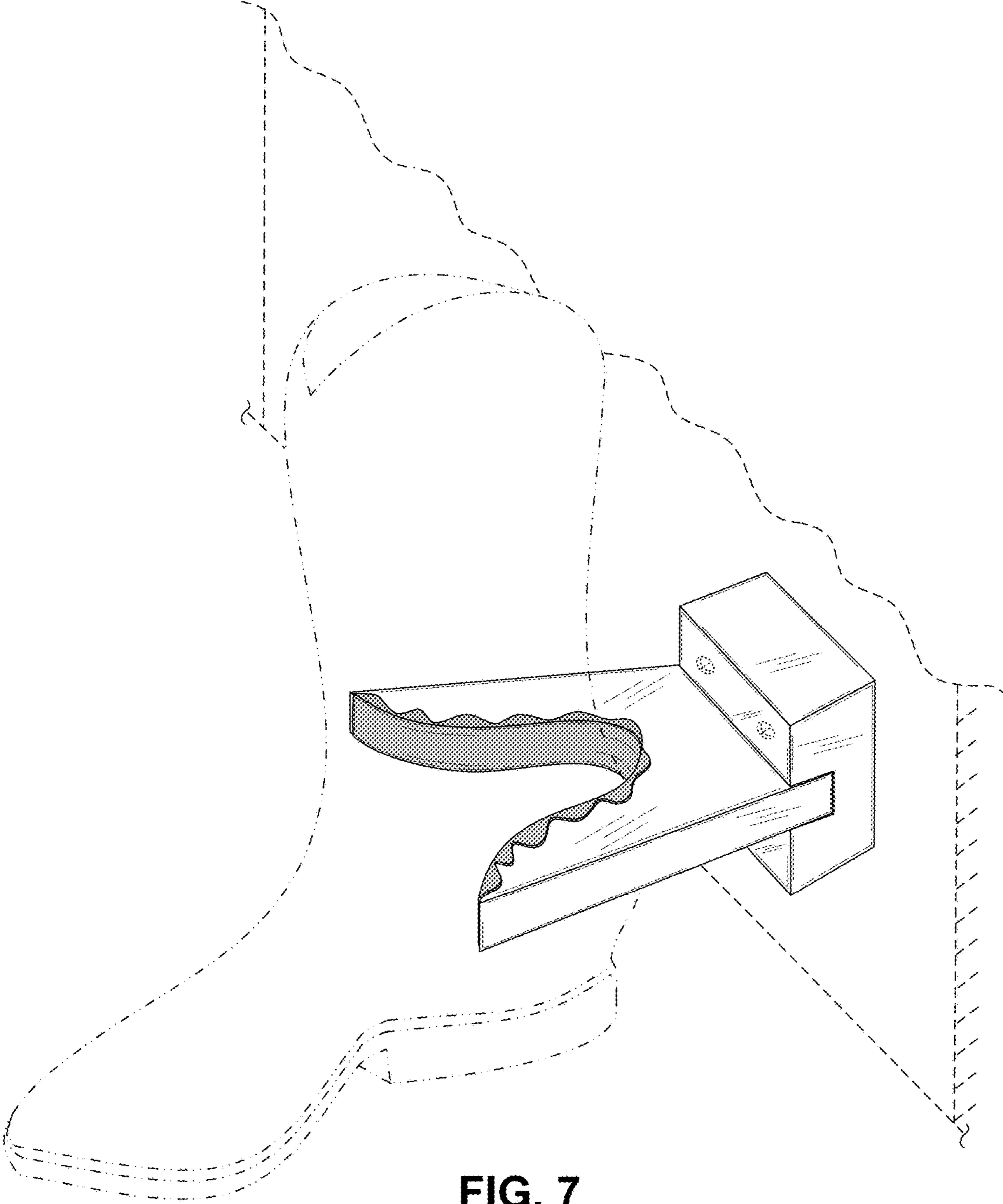
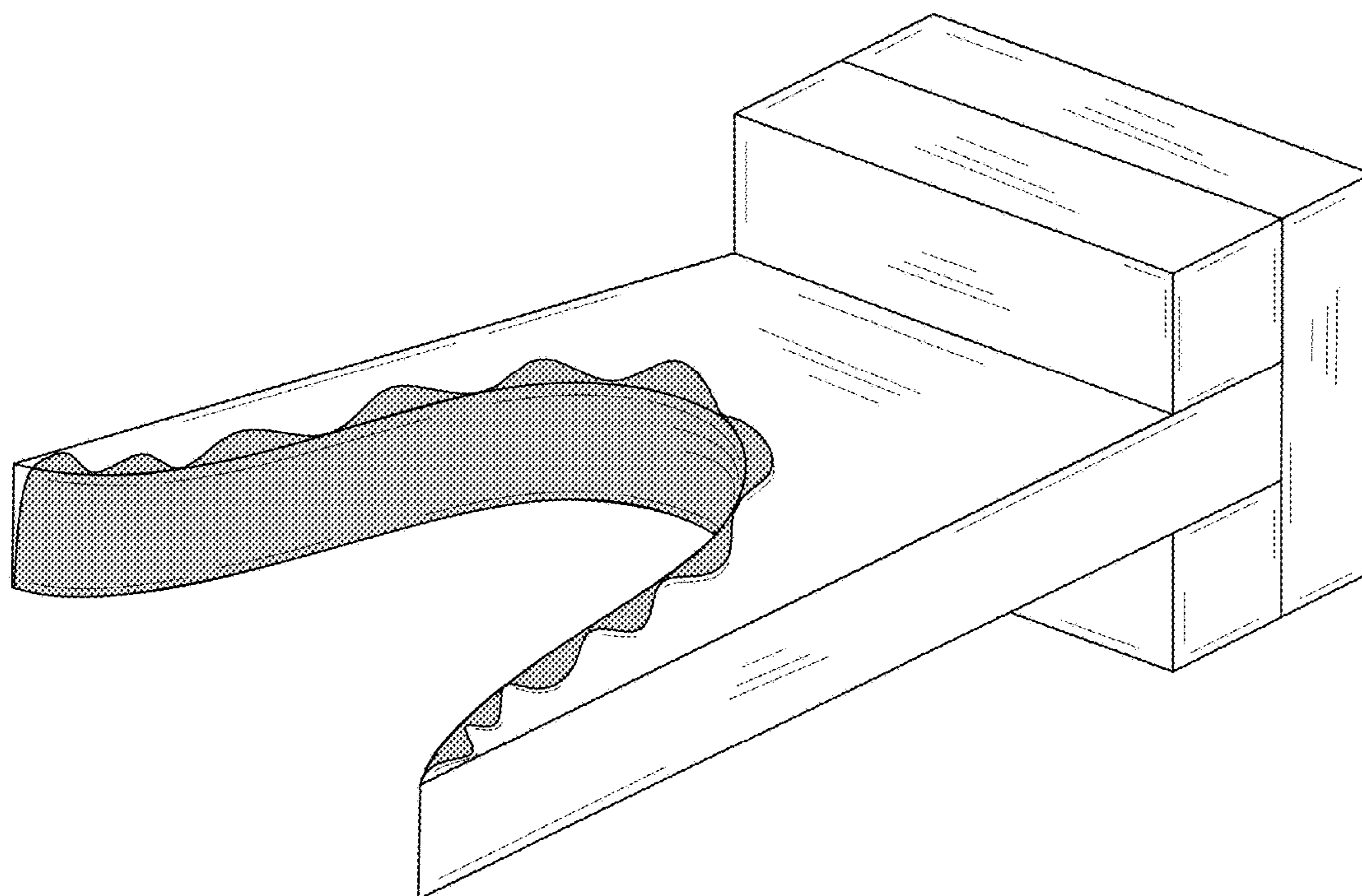
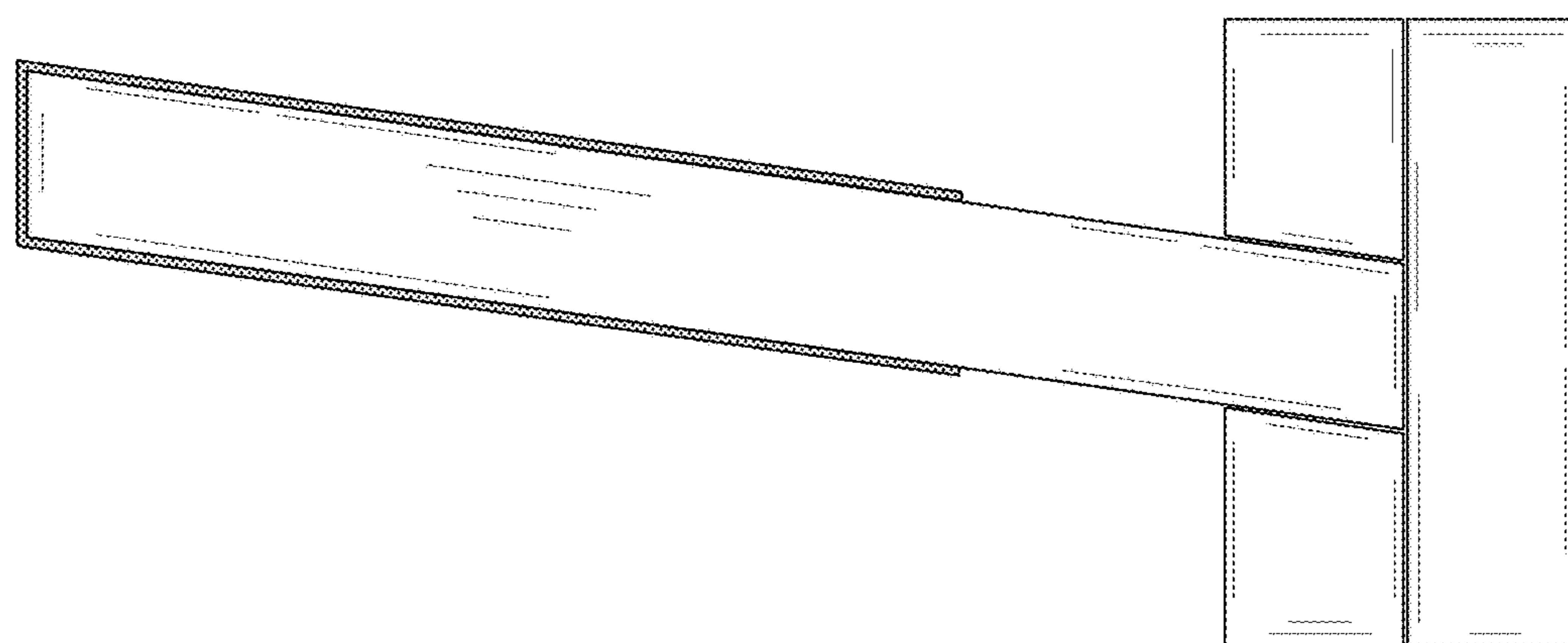

FIG. 7

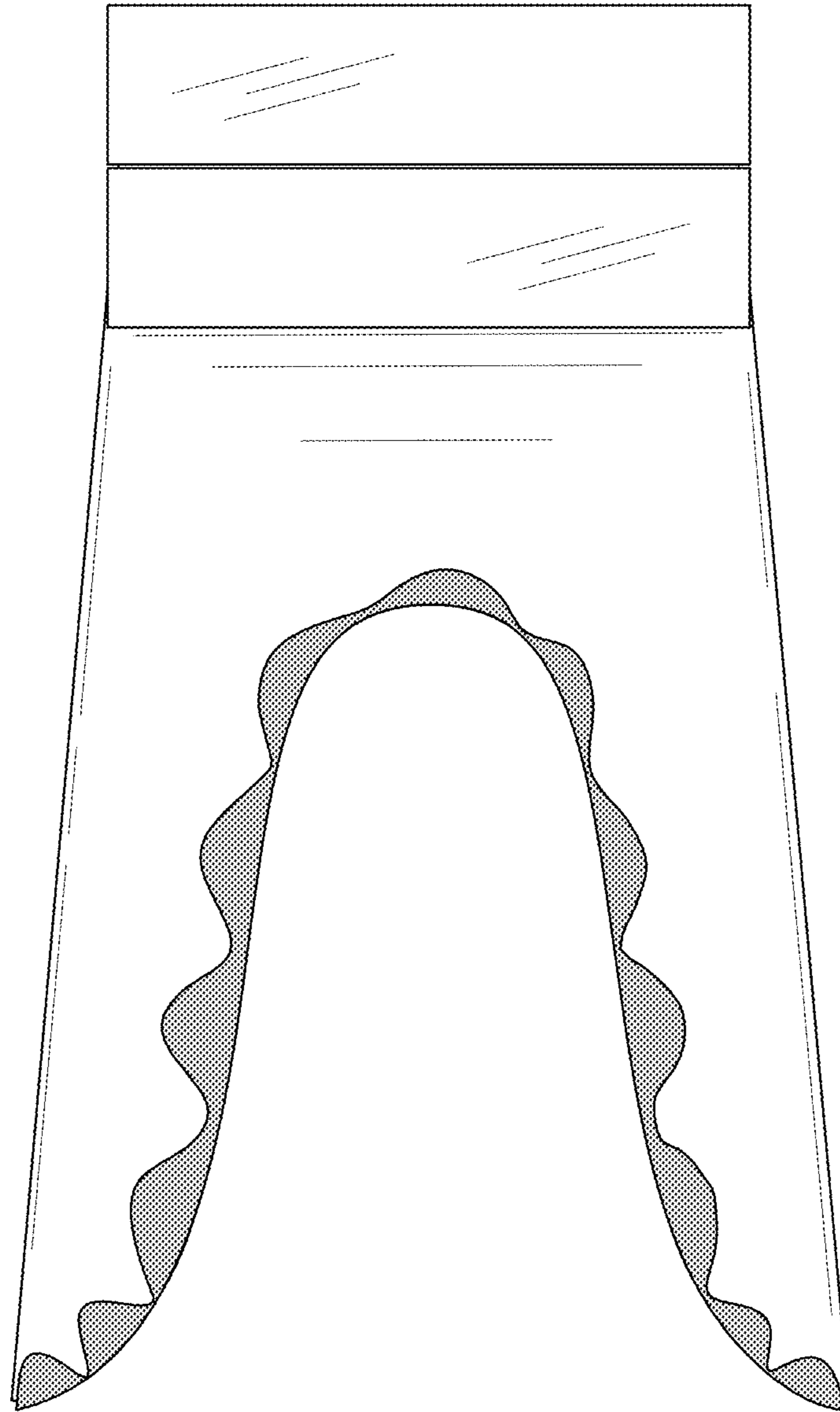

**FIG. 8**

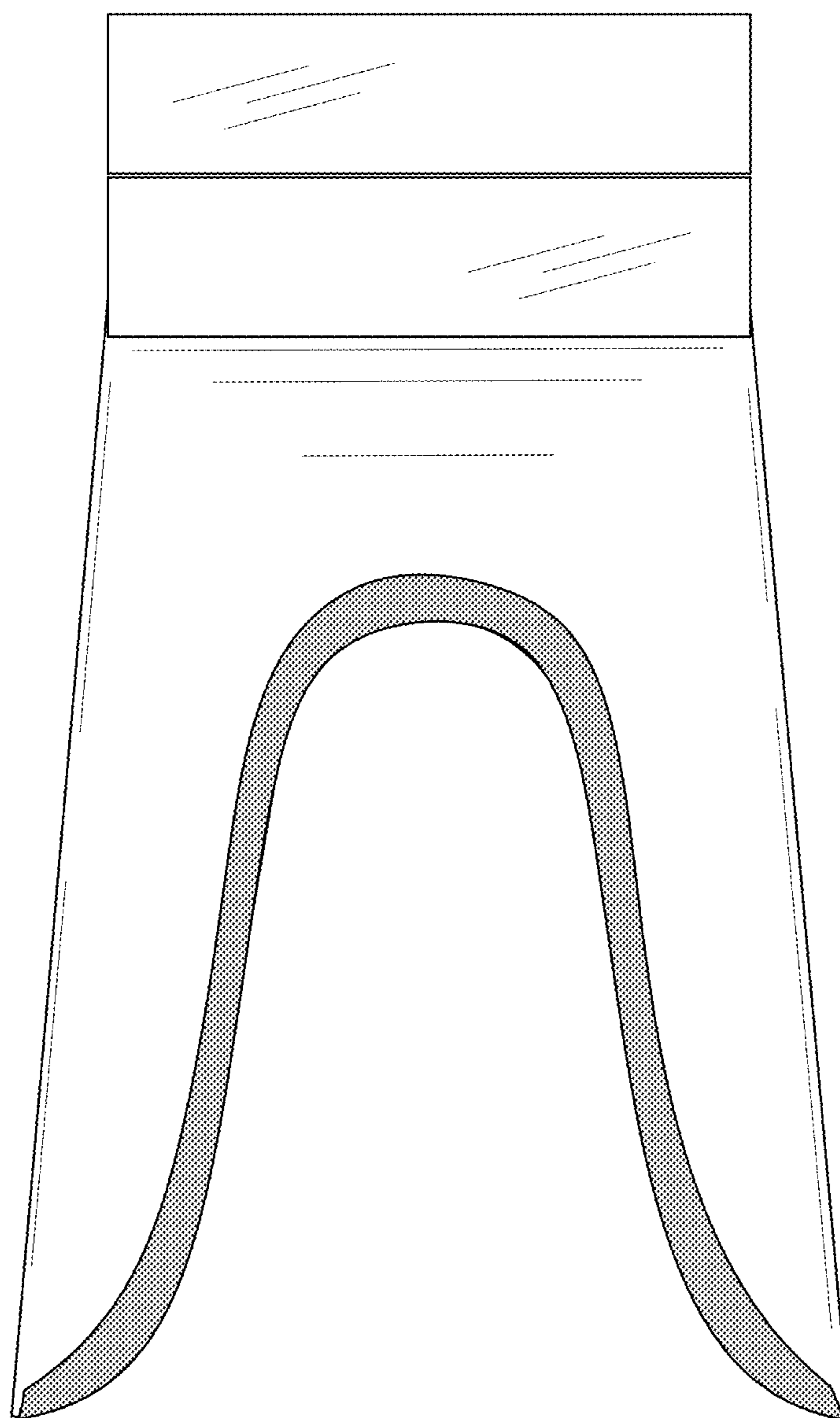

**FIG. 9**





**FIG. 10**



**FIG. 11**