



US00D784014S

(12) **United States Design Patent**  
**Scranton**

(10) **Patent No.:** **US D784,014 S**

(45) **Date of Patent:** **\*\* Apr. 18, 2017**

- (54) **HANDGUN CASE**
- (71) Applicant: **Joshua Scranton**, Broomfield, CO (US)
- (72) Inventor: **Joshua Scranton**, Broomfield, CO (US)
- (73) Assignee: **The Allen Company, Inc.**, Broomfield, CO (US)
- (\*\*) Term: **15 Years**
- (21) Appl. No.: **29/546,505**
- (22) Filed: **Nov. 23, 2015**
- (51) **LOC (10) Cl.** ..... **03-01**
- (52) **U.S. Cl.**  
USPC ..... **D3/262; D3/222**
- (58) **Field of Classification Search**  
USPC ..... D3/201, 222, 232, 245, 246, 262, 269,  
D3/273, 276, 289, 301  
CPC ..... F41C 33/02-33/08  
See application file for complete search history.

6,547,070	B1 *	4/2003	Kolpin .....	F41C 33/06 190/102
6,634,530	B1	10/2003	Black	
D486,637	S	2/2004	Sauvey et al.	
6,722,496	B2	4/2004	Gantert	
D520,235	S	5/2006	Blaschke	
7,063,737	B2 *	6/2006	Tilby .....	F41C 33/06 190/125
D528,790	S	9/2006	Sides	
D528,791	S	9/2006	Sides	
7,434,683	B1	10/2008	Harper et al.	
7,546,920	B1	6/2009	Horn et al.	
7,905,350	B2	3/2011	Wood et al.	
D725,382	S *	3/2015	Gazso .....	D3/222
D728,232	S *	5/2015	Stevens, IV .....	D3/262
2016/0123700	A1 *	5/2016	Manglos .....	F42B 39/02 150/112

\* cited by examiner

*Primary Examiner* — Mitchell Siegel

(74) *Attorney, Agent, or Firm* — Boyd D. Cox

(57) **CLAIM**

The ornamental design for a handgun case, as shown.

**DESCRIPTION**

FIG. 1 is a front elevation of the handgun case of the present invention;  
 FIG. 2 is a rear elevation of the handgun case of FIG. 1;  
 FIG. 3 is a right side elevation of the handgun case of FIG. 1, the left side elevation being the mirror image of the right side elevation;  
 FIG. 4 is a top plan view of the handgun case of FIG. 1; and,  
 FIG. 5 is a bottom plan view of the handgun case of FIG. 1.

**1 Claim, 5 Drawing Sheets**

(56) **References Cited**

U.S. PATENT DOCUMENTS

4,190,183	A *	2/1980	Yates .....	F41C 33/0218 224/235
D270,929	S *	10/1983	Shasteen .....	D3/222
D347,322	S	5/1994	Fiore	
D358,255	S	5/1995	Sharp et al.	
5,669,495	A	9/1997	West	
D448,164	S *	9/2001	Kolpin .....	D3/262
D448,560	S	10/2001	Kolpin	
D448,561	S	10/2001	Kolpin	
D448,562	S	10/2001	Kolpin	

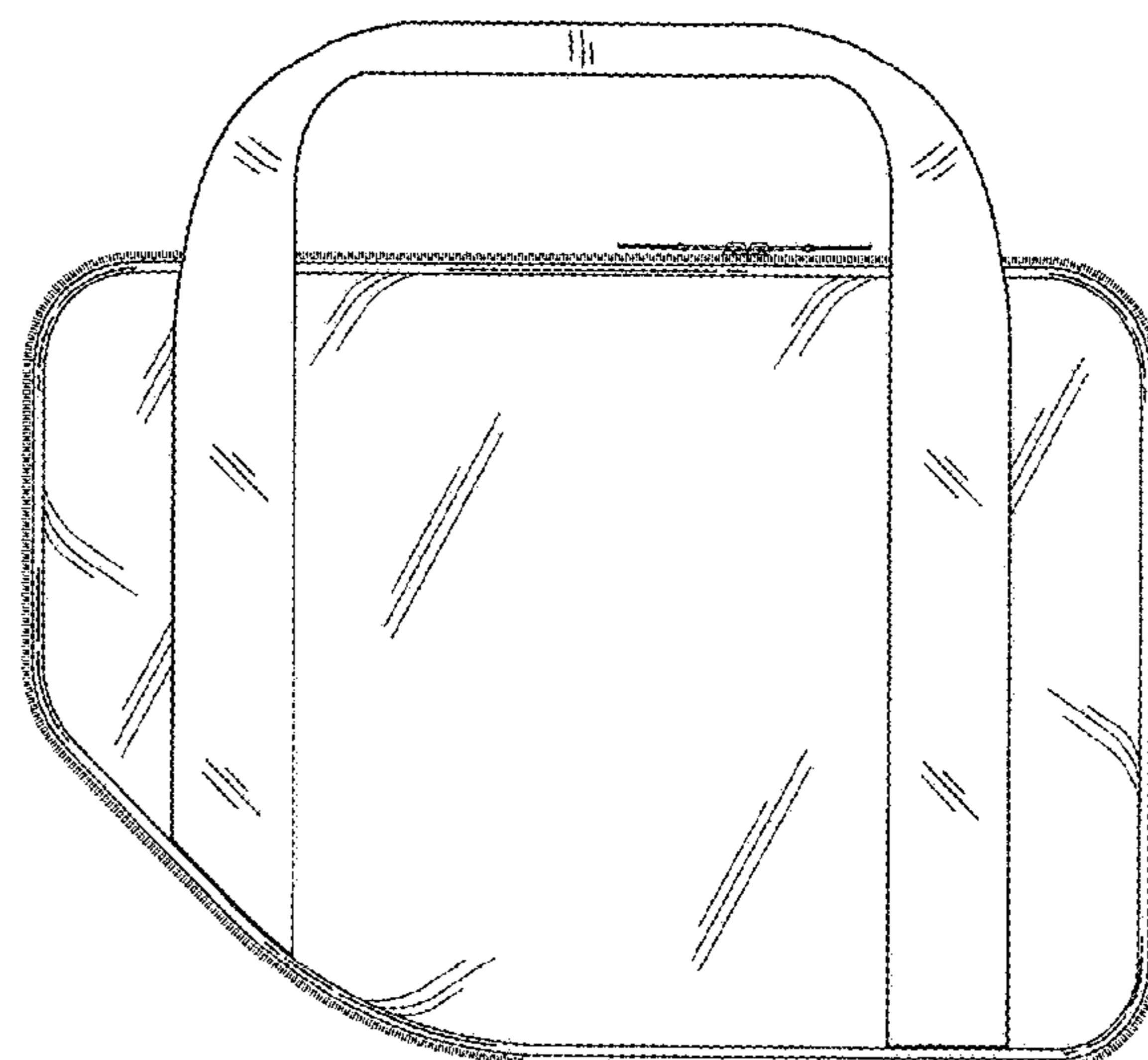
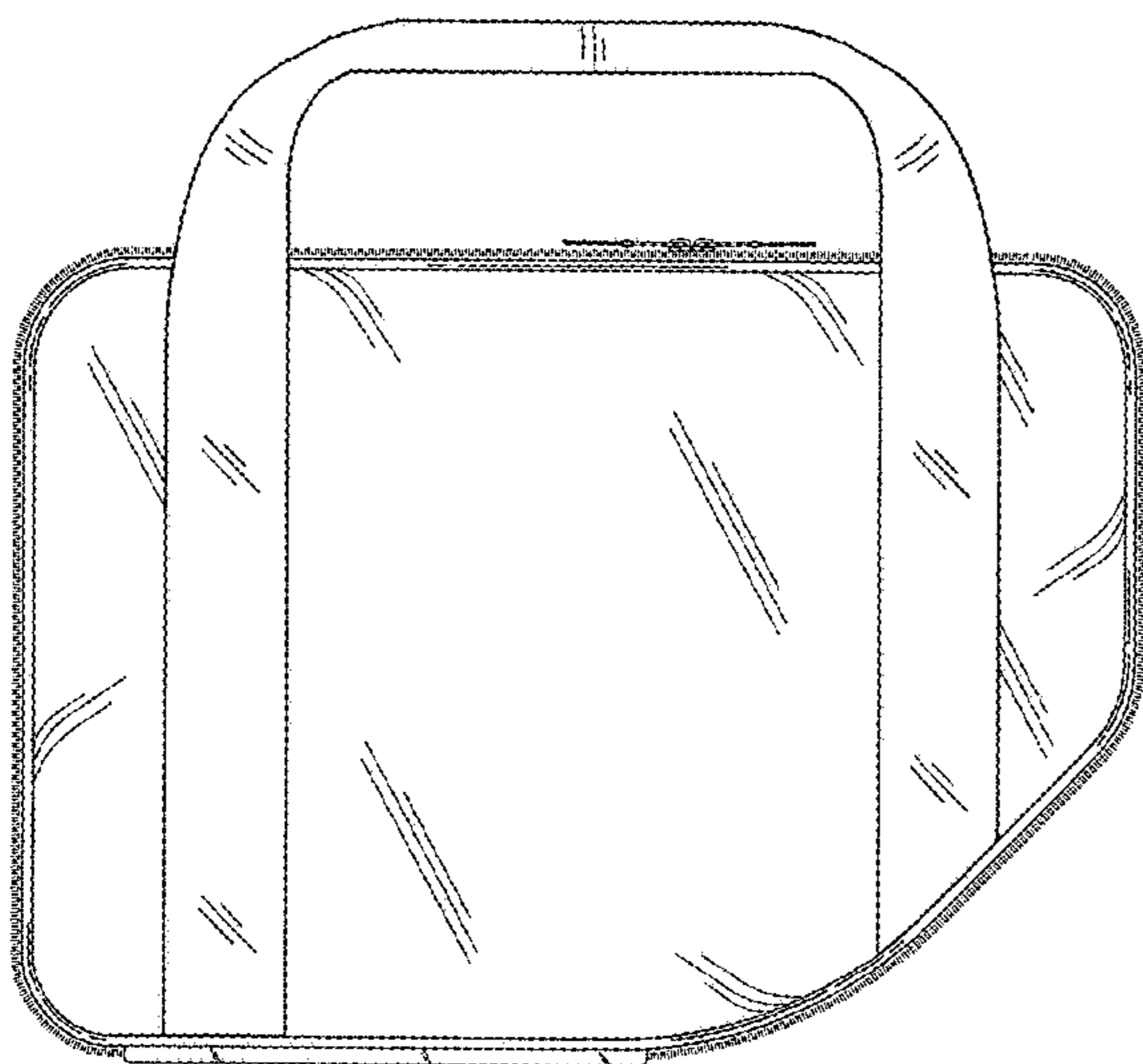

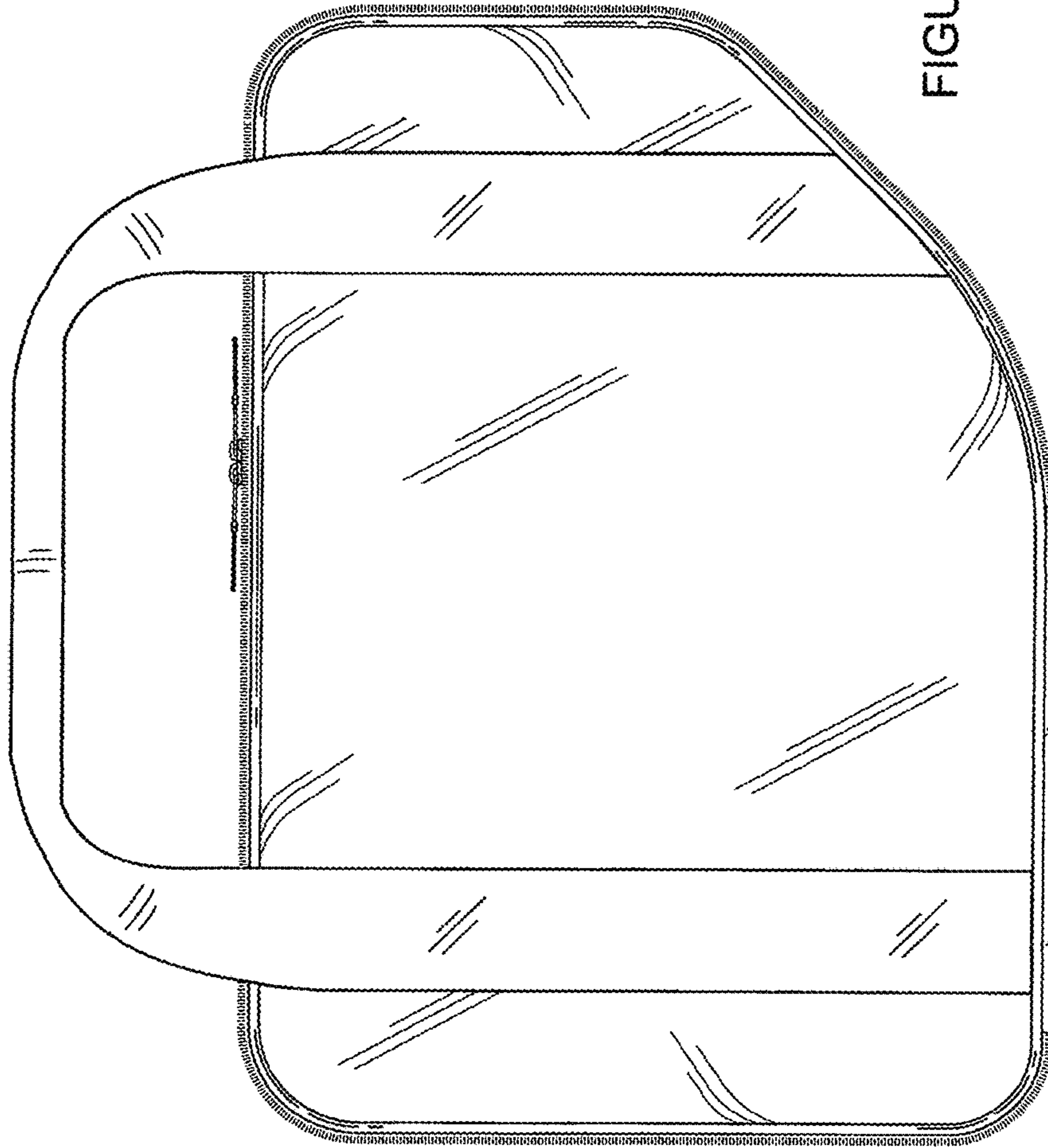

FIGURE 1

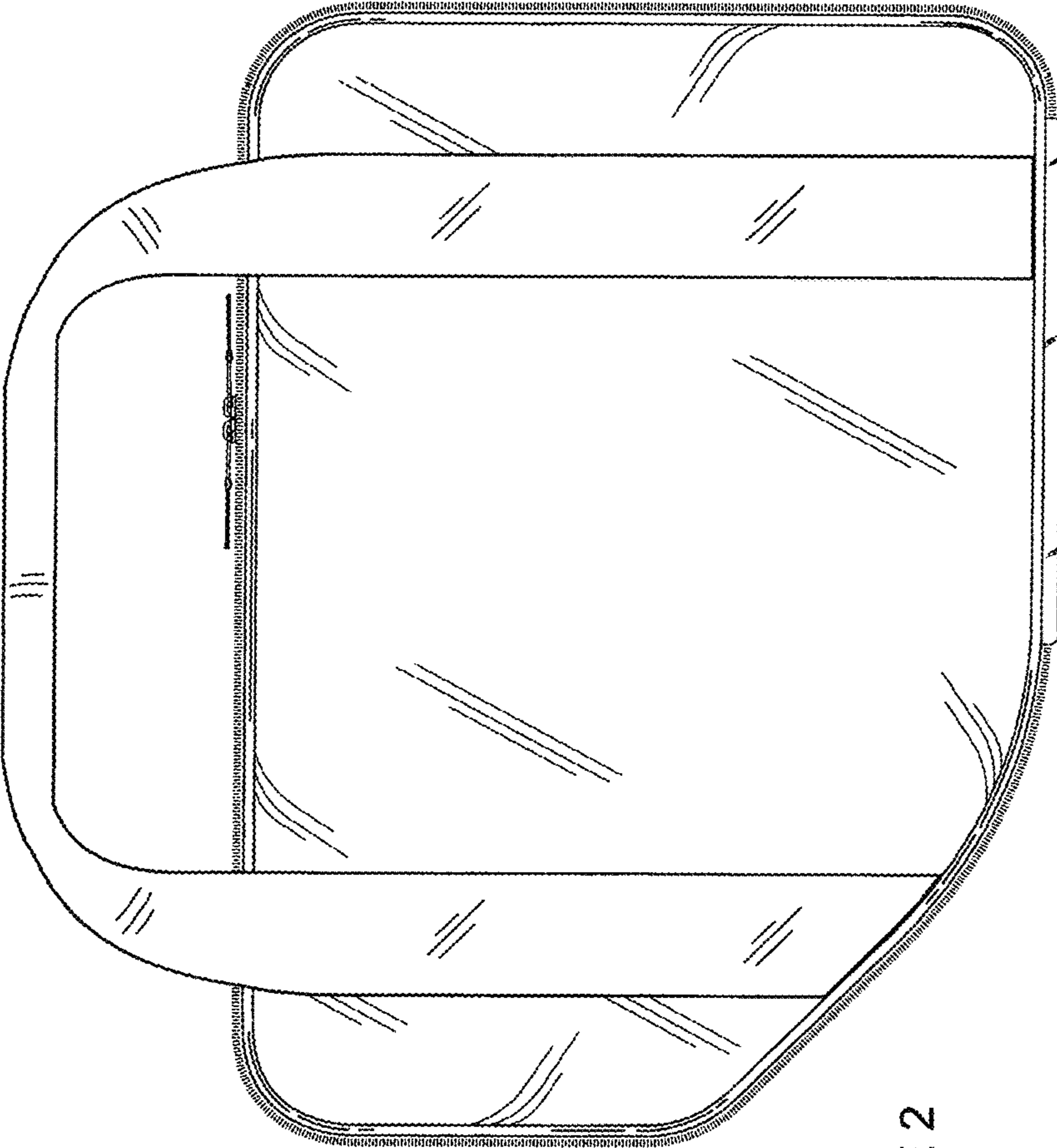

FIGURE 2

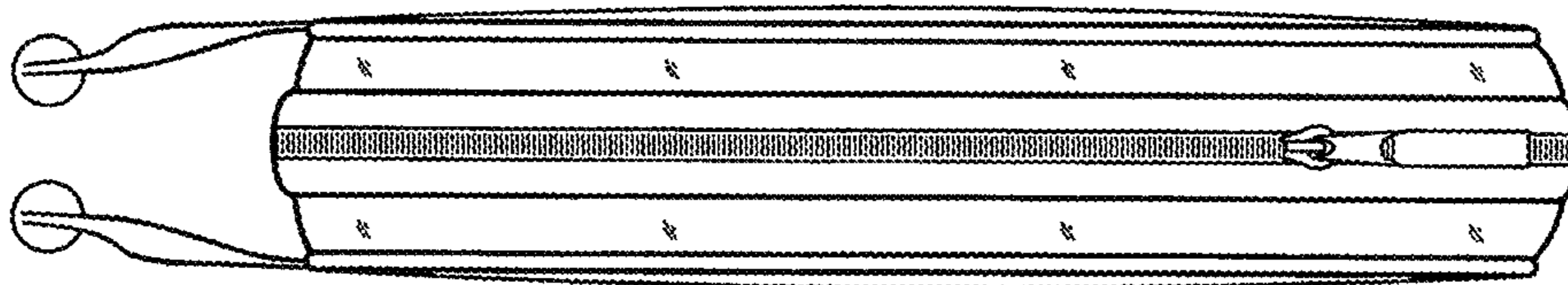

FIGURE 3

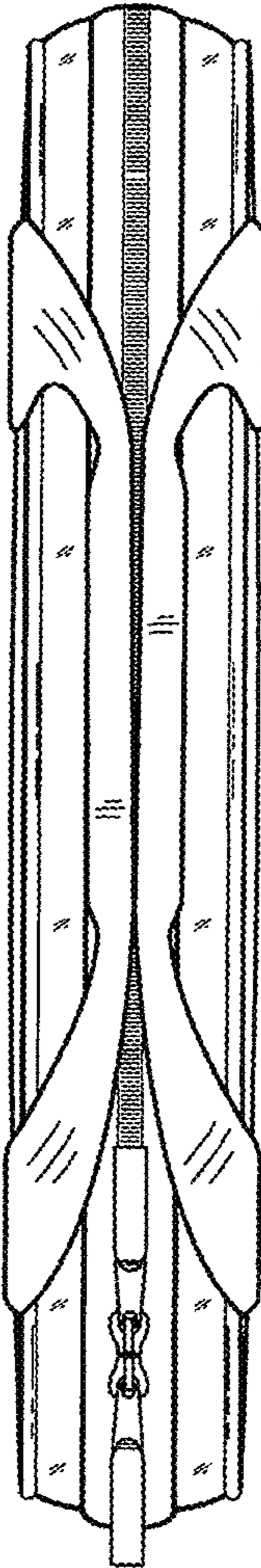

FIGURE 4

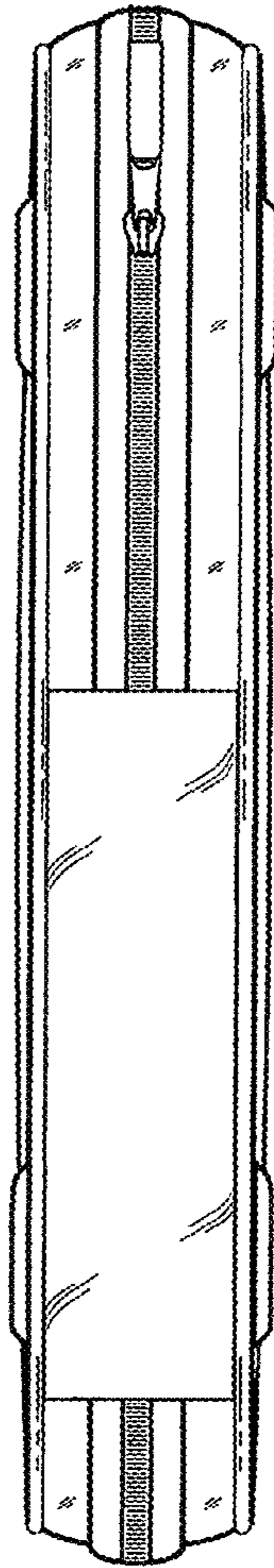

FIGURE 5