



US00D783869S

(12) **United States Design Patent**
Shiu

(10) **Patent No.:** **US D783,869 S**

(45) **Date of Patent:** **** Apr. 11, 2017**

(54) **HEADLIGHT/REAR-LIGHT ASSEMBLY**

(71) Applicant: **Gold Coral International Limited,**
Kowloon (HK)

(72) Inventor: **Stephanie Wai Man Shiu,** Kowloon
(HK)

(73) Assignee: **GOLD CORAL INTERNATIONAL LIMITED,** Kowloon (HK)

(**) Term: **15 Years**

(21) Appl. No.: **29/540,532**

(22) Filed: **Sep. 25, 2015**

(51) **LOC (10) Cl.** **26-07**

(52) **U.S. Cl.**
USPC **D26/28**

(58) **Field of Classification Search**
USPC D26/28-36; 362/459-468, 475-478,
362/485-487
CPC F21S 48/00; F21S 48/10; F21S 48/115;
F21S 48/225; F21S 48/1233; F21S
48/1266; F21S 48/1388; F21S 48/2268;
F21V 21/04
See application file for complete search history.

(56) **References Cited**

U.S. PATENT DOCUMENTS

D471,656 S *	3/2003	Poon	D26/28
D483,505 S *	12/2003	Schwerdtmann	D26/28
D492,047 S *	6/2004	Dohogne	D26/28
D514,239 S *	1/2006	Okuda	D26/28
D568,502 S *	5/2008	Kudo	D26/28
D592,779 S *	5/2009	Svensson	D26/28
D630,353 S *	1/2011	Reinbach	D26/28
D640,181 S *	6/2011	Calvin	D12/345

D736,434 S *	8/2015	Kuei-Lai	D26/28
D738,552 S *	9/2015	Heiner	D26/31
D739,584 S *	9/2015	Heiner	D26/31
D752,252 S *	3/2016	Ruthling	D26/28
D761,984 S *	7/2016	Kobayashi	D26/28

* cited by examiner

Primary Examiner — Angela J Lee

(74) *Attorney, Agent, or Firm* — Joseph G. Swan, P.C.

(57) **CLAIM**

The ornamental design for a headlight/rear-light assembly, as shown and described.

DESCRIPTION

FIG. 1 is a front perspective view of a headlight/rear-light assembly according to the present invention.

FIG. 2 is a left side perspective view of the headlight/rear-light assembly.

FIG. 3 is a front elevational view of the headlight/rear-light assembly.

FIG. 4 is a rear elevational view of the headlight/rear-light assembly.

FIG. 5 is a left side elevational view of the headlight/rear-light assembly.

FIG. 6 is a right side elevational view of the headlight/rear-light assembly.

FIG. 7 is a top plan view of the headlight/rear-light assembly; and,

FIG. 8 is a bottom plan view of the headlight/rear-light assembly.

The portions shown in broken lines are solely for the purpose of illustrating context, environment or other unclaimed areas and form no part of the claimed design.

1 Claim, 6 Drawing Sheets

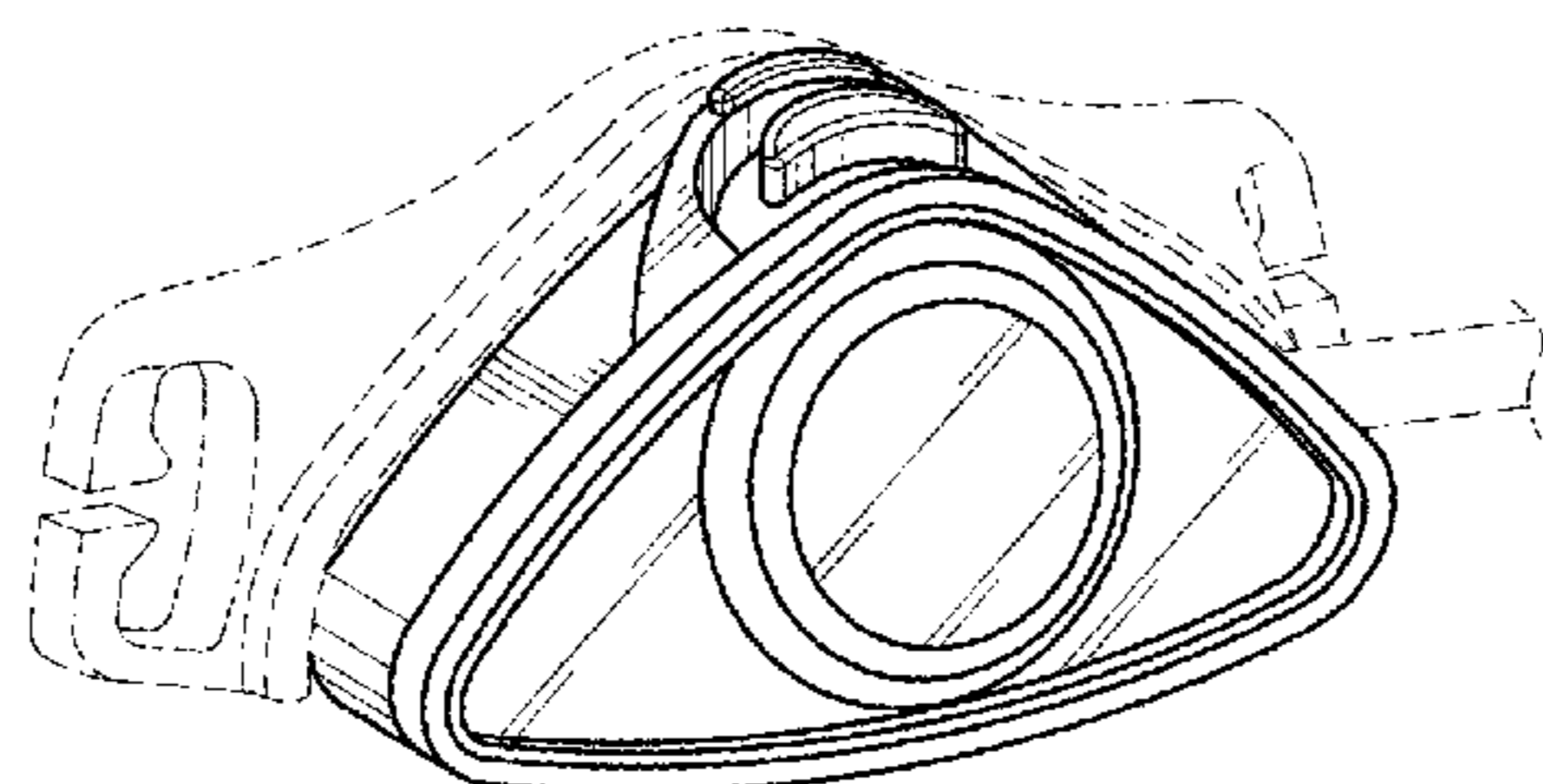
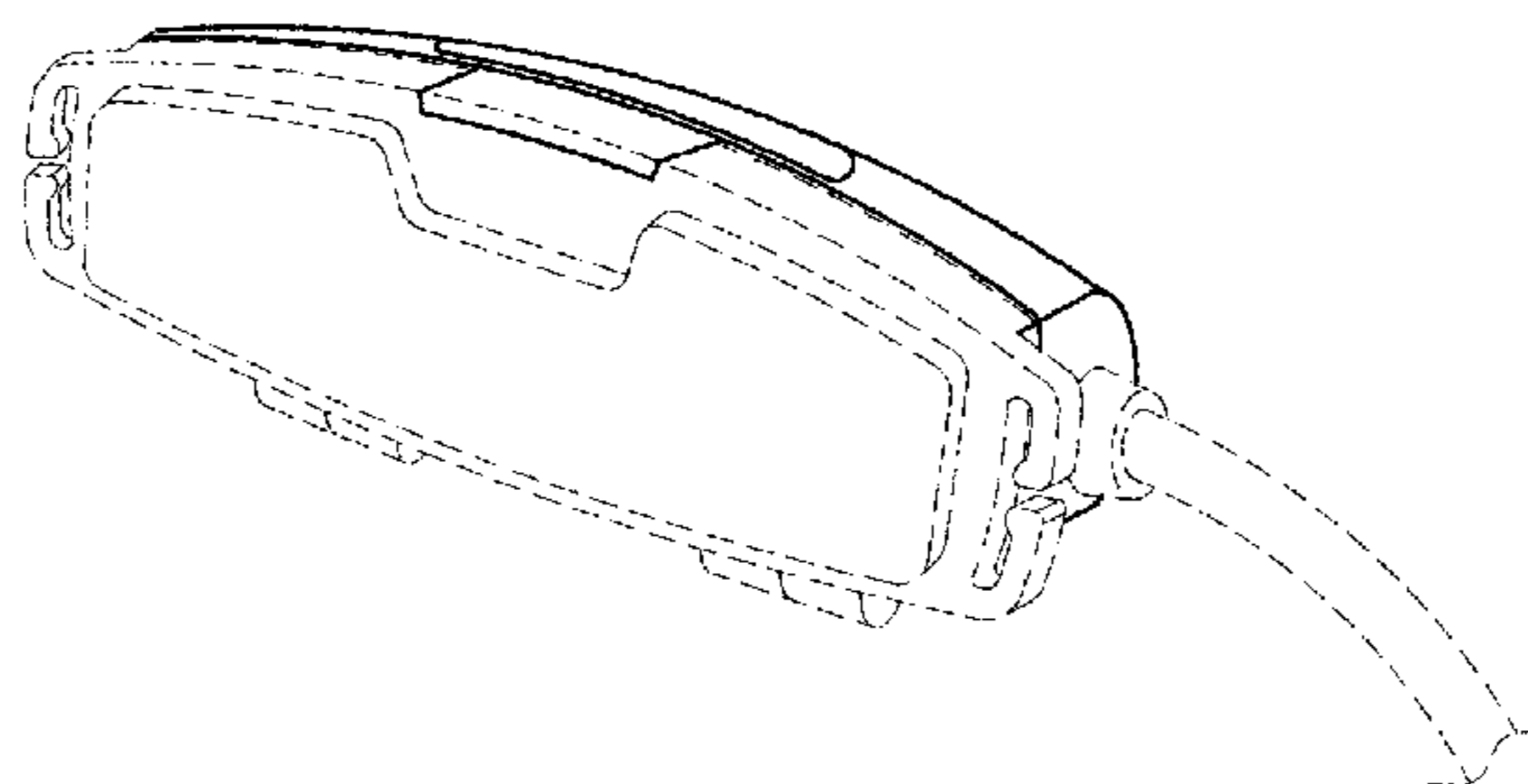

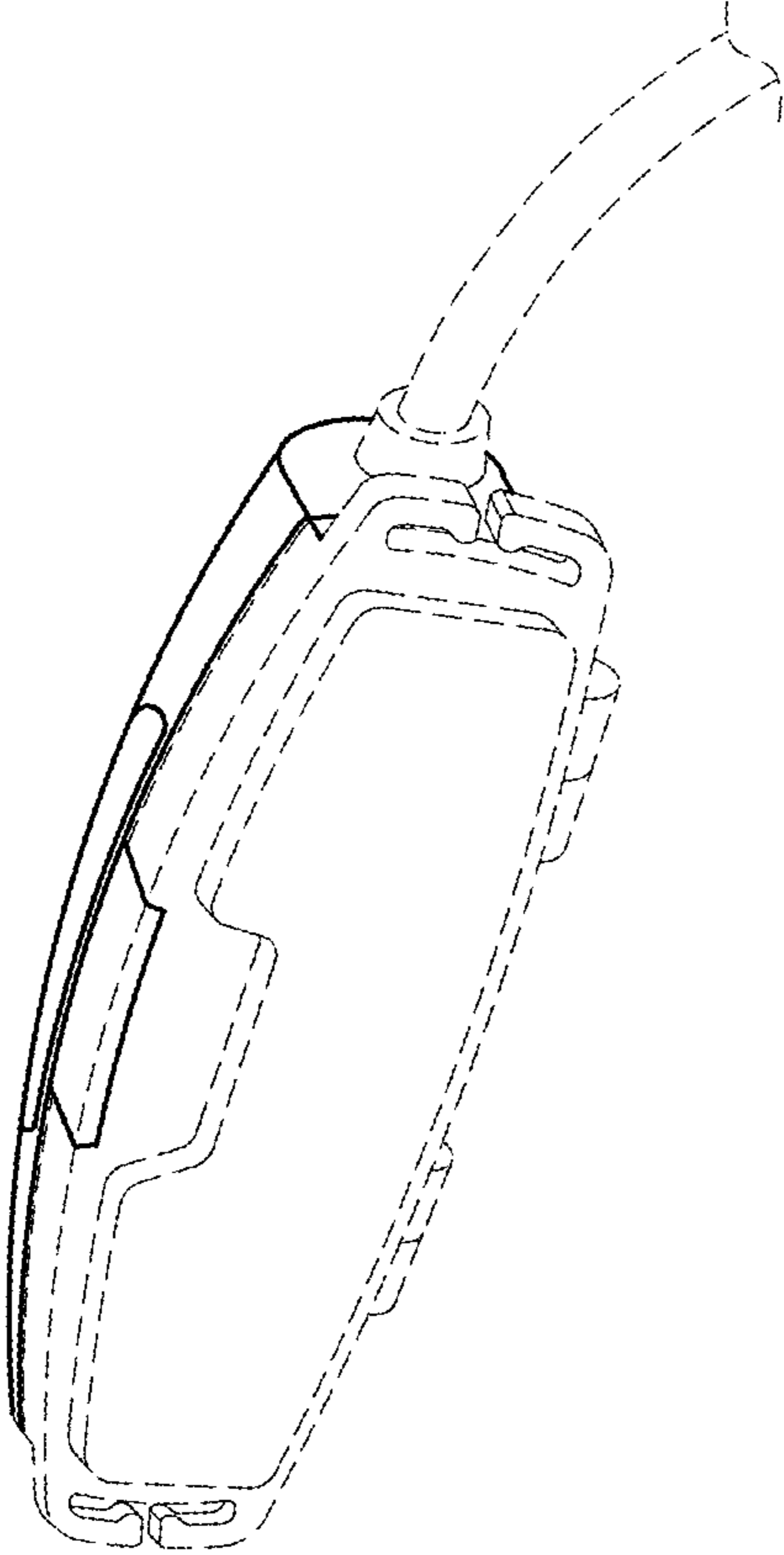
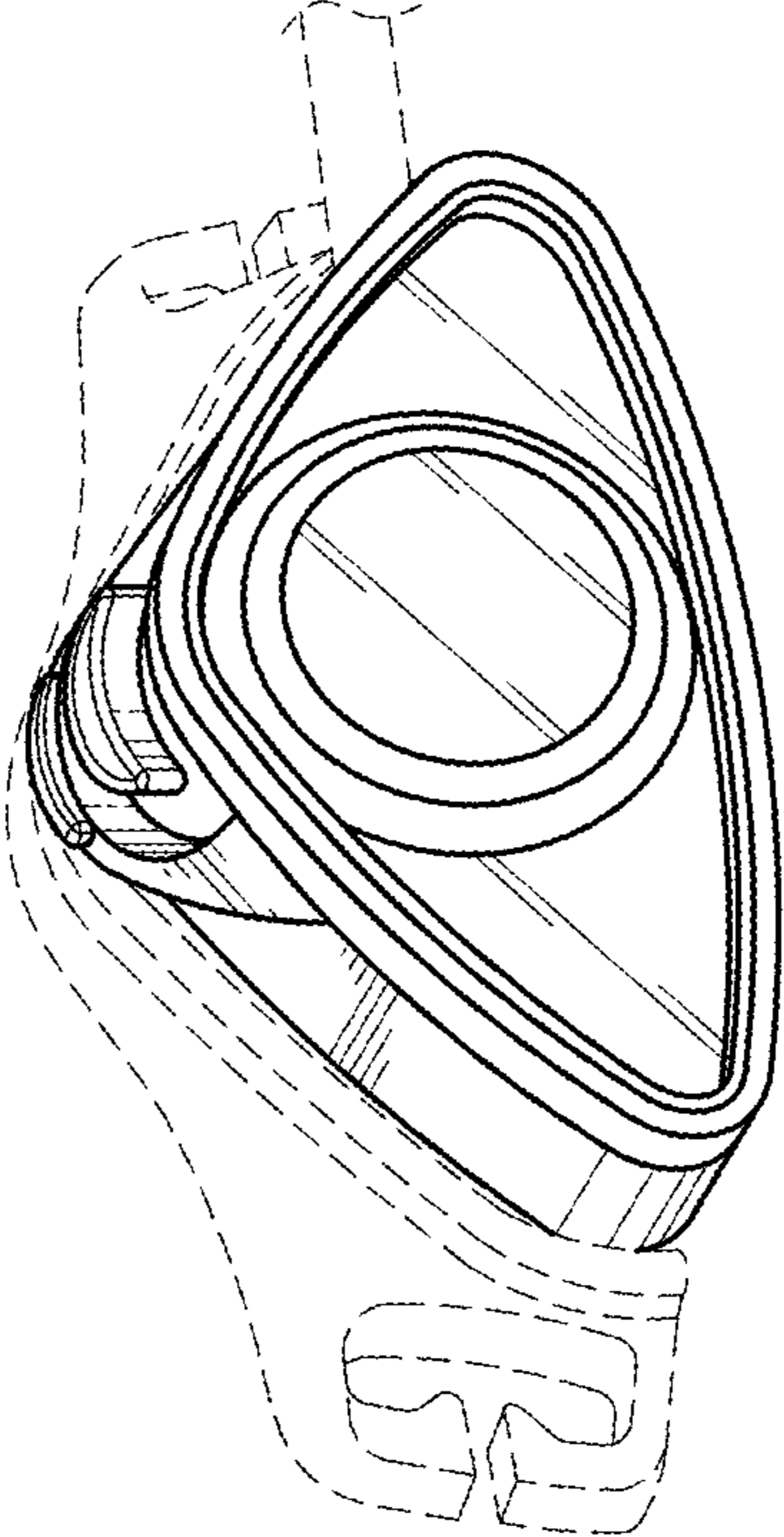

FIG. 1



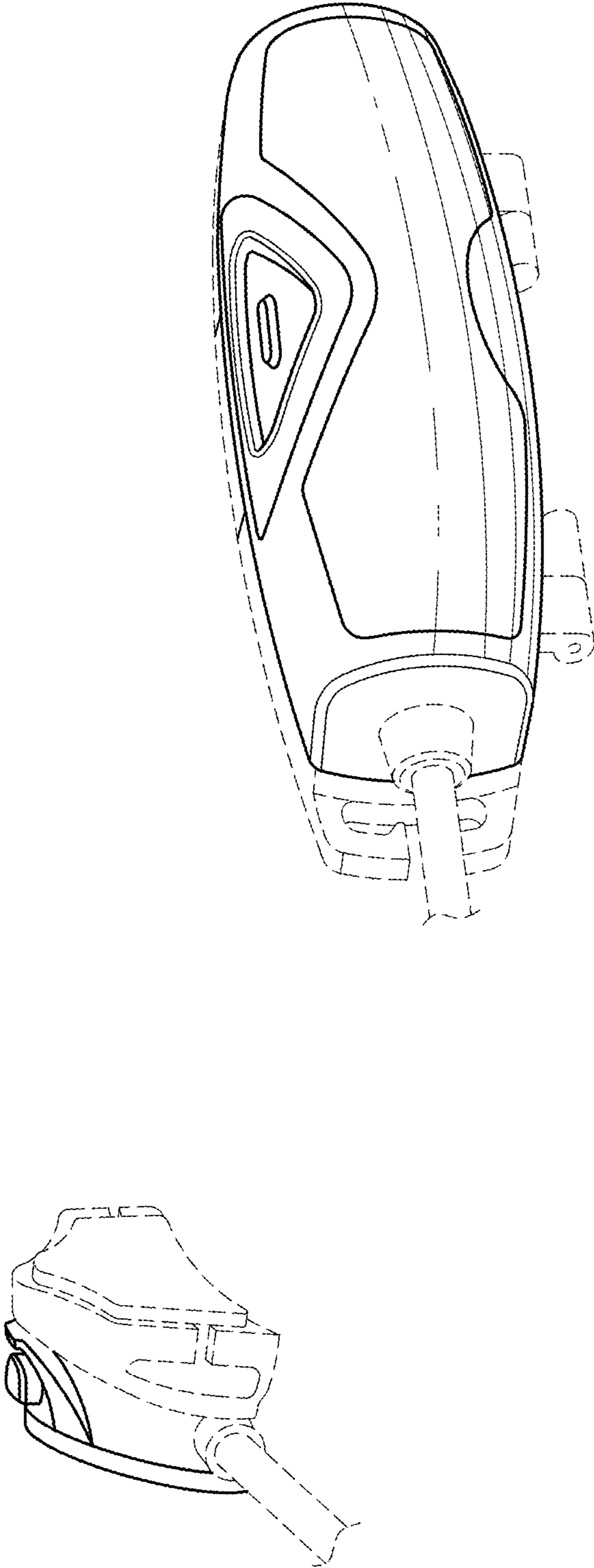

FIG. 2

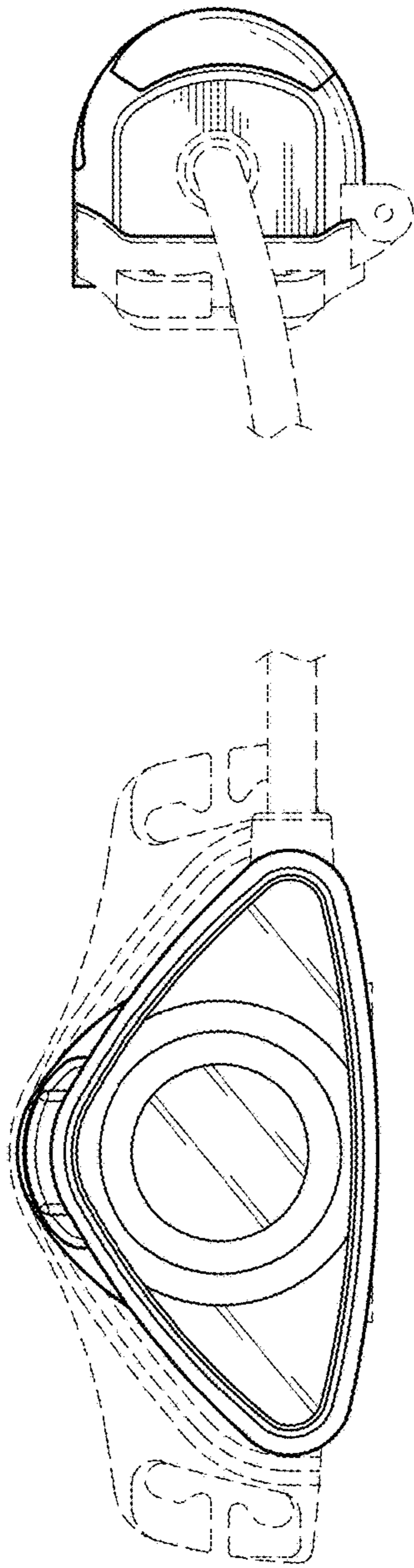

FIG. 3

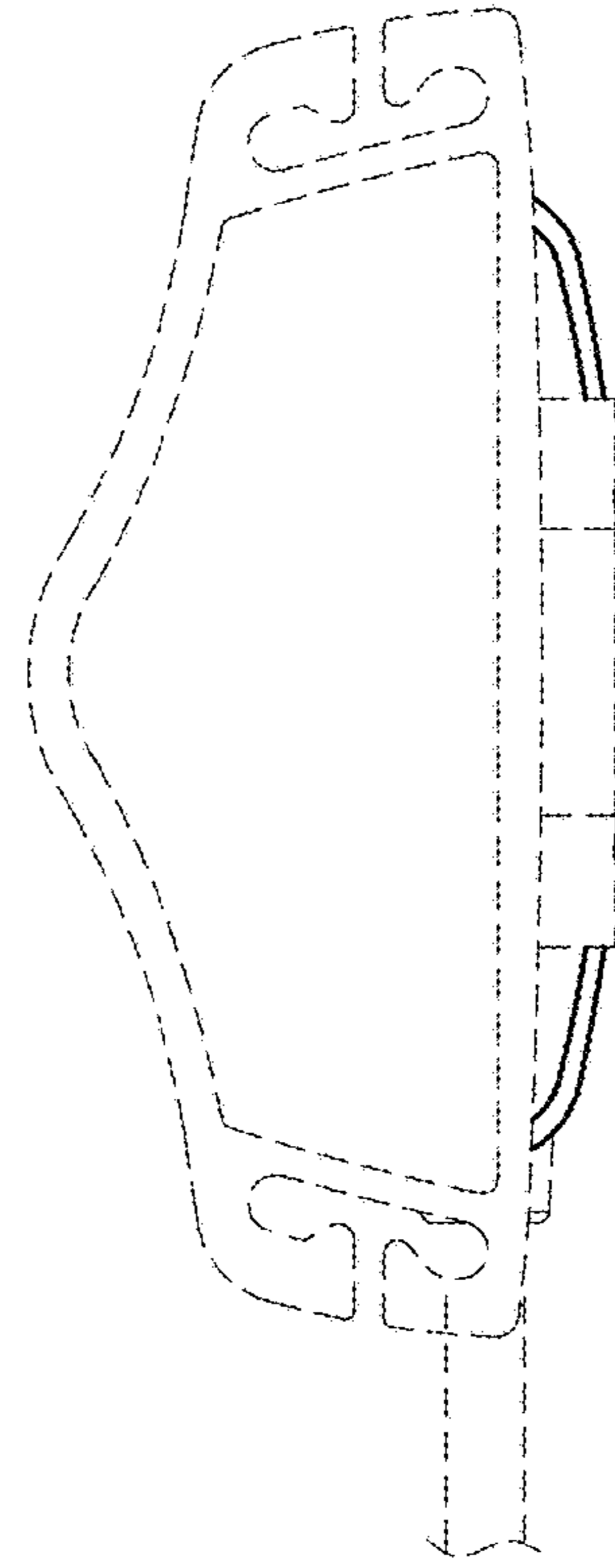
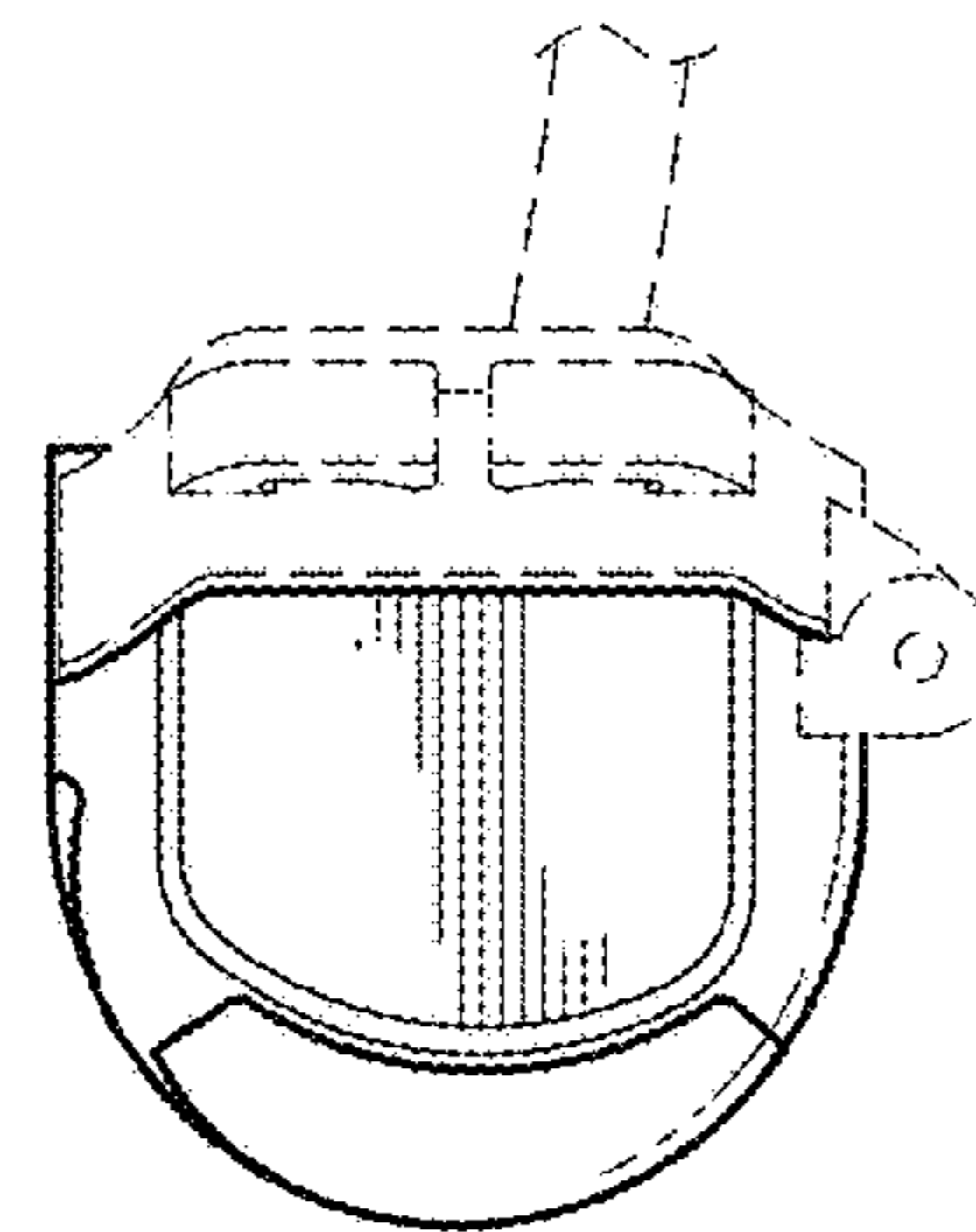

FIG. 4



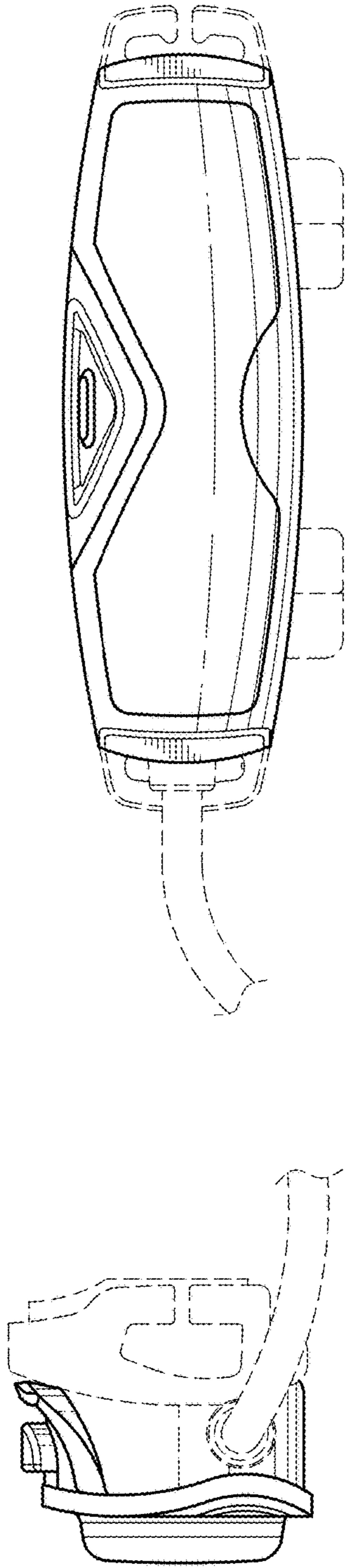

FIG. 5

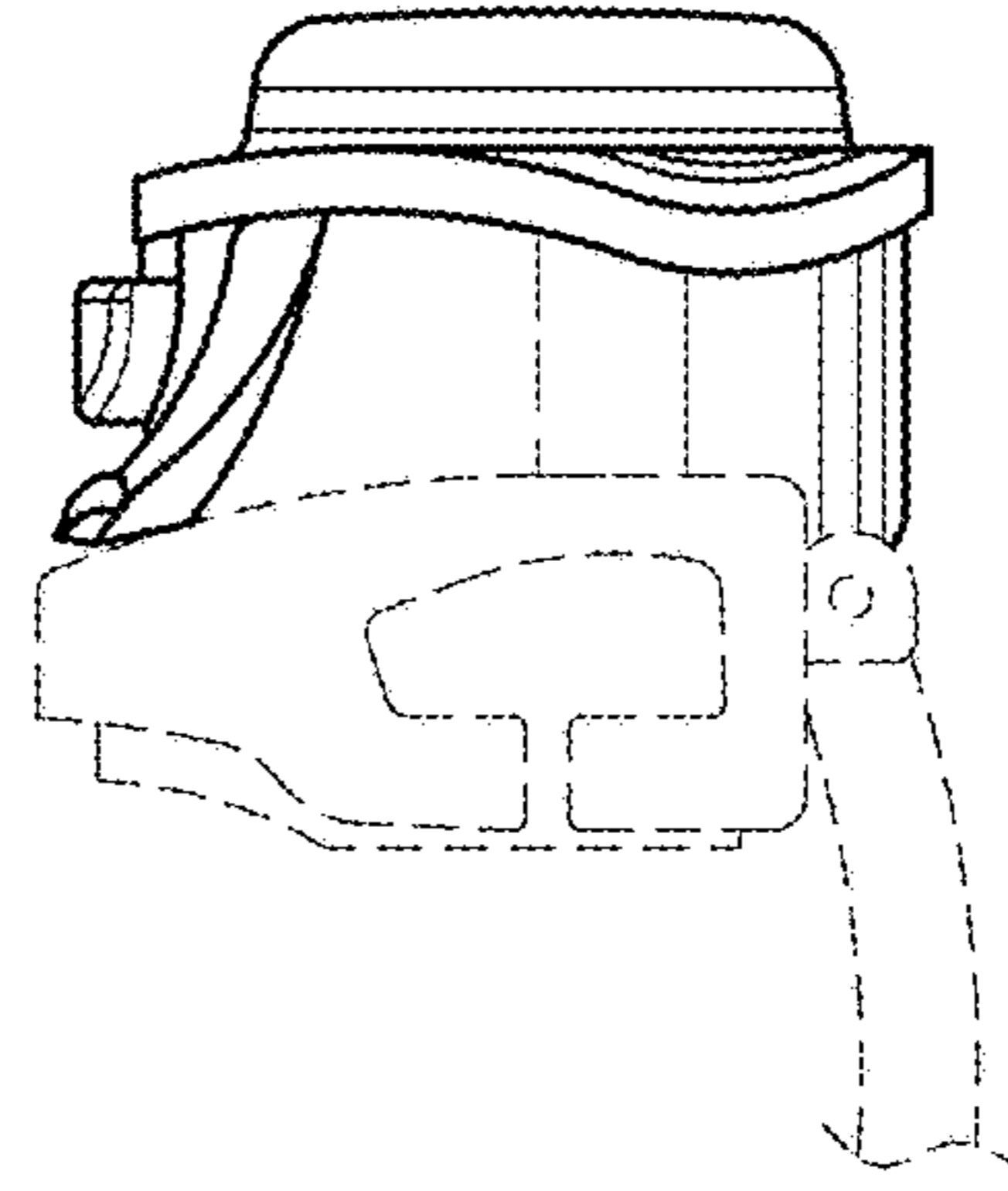

FIG. 6

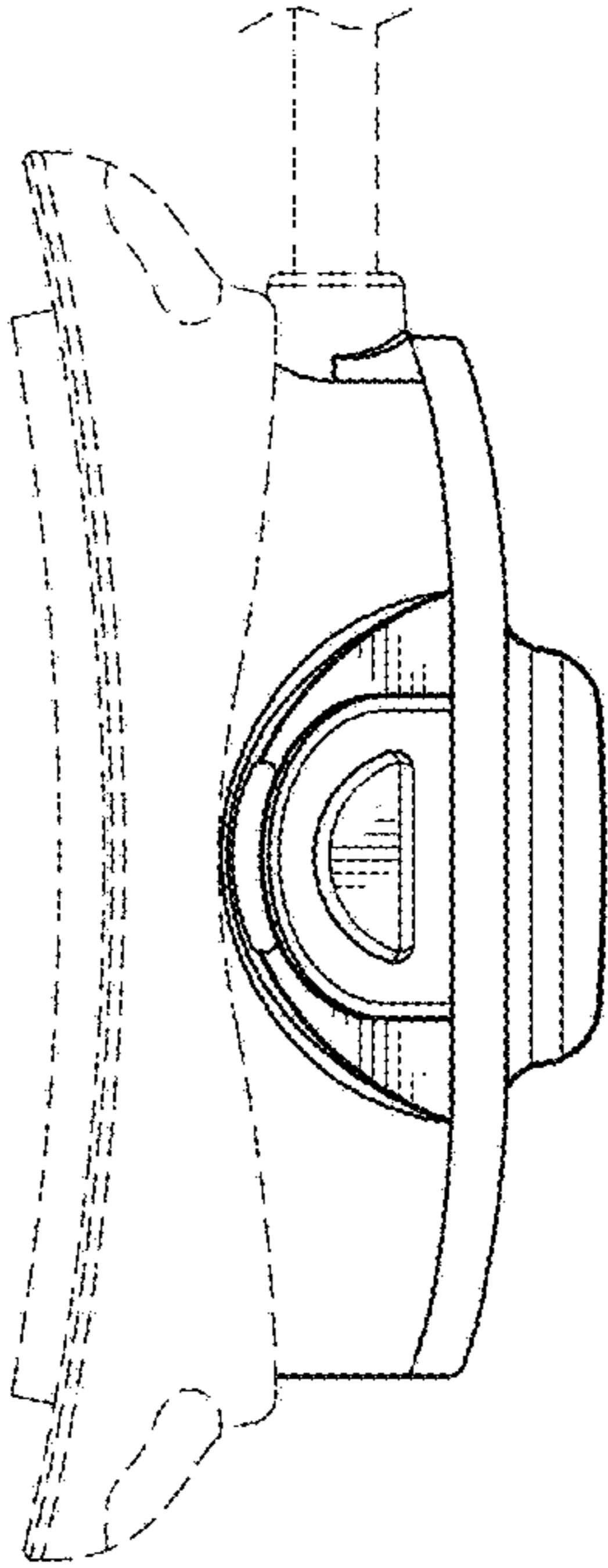
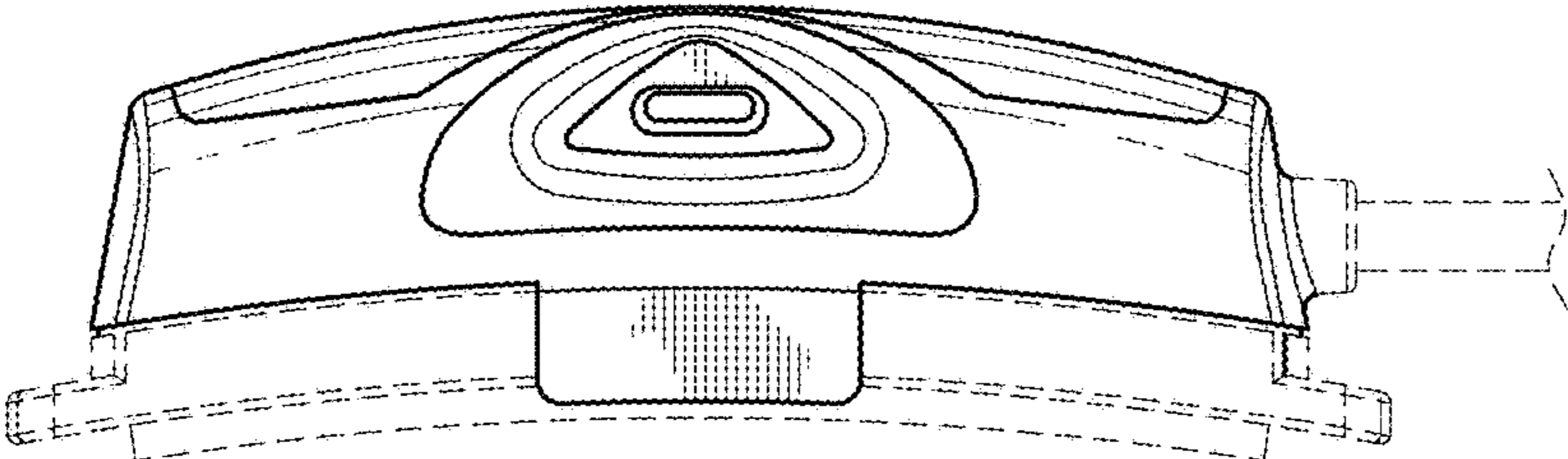

FIG. 7

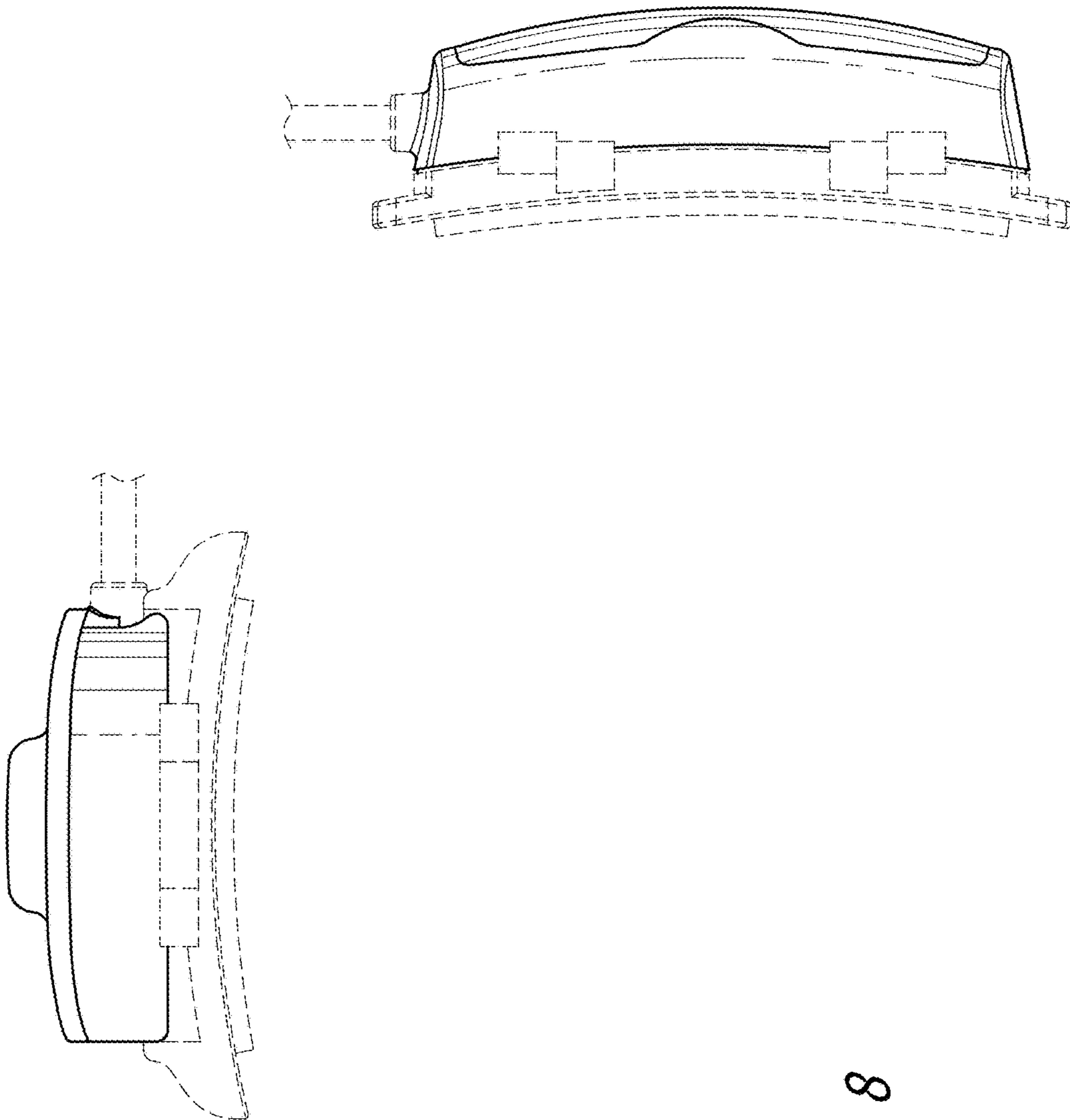

FIG. 8