



US00D783726S

(12) **United States Design Patent** (10) **Patent No.:** **US D783,726 S**
Williams et al. (45) **Date of Patent:** **** Apr. 11, 2017**

(54) **VEHICLE FRAME**

(56) **References Cited**

(71) Applicants: **Calvin John Llewelyn Williams,**
Swansea (GB); **Paul Howard Davies,**
Ammanford (GB)

U.S. PATENT DOCUMENTS

(72) Inventors: **Calvin John Llewelyn Williams,**
Swansea (GB); **Paul Howard Davies,**
Ammanford (GB)

D251,185 S	2/1979	Cummings	
5,042,607 A	8/1991	Falkenson et al.	
D467,203 S	12/2002	Potter et al.	
D500,707 S *	1/2005	Lu	D12/87
D503,658 S *	4/2005	Lu	D12/87
D549,133 S *	8/2007	LePage	D12/87
D563,274 S *	3/2008	Ramos	D12/87
D564,410 S *	3/2008	Lepage	D12/87
D574,297 S *	8/2008	Carl	D12/87
D575,675 S *	8/2008	Williams	D12/87
D586,261 S *	2/2009	Burns	D12/87
D586,695 S *	2/2009	Burns	D12/87
D586,696 S *	2/2009	Burns	D12/87
7,823,674 B2	11/2010	Bowles et al.	
D651,133 S *	12/2011	Liebl	D12/86
8,146,689 B2	4/2012	Hertema	

(**) Term: **15 Years**

(21) Appl. No.: **29/505,683**

(22) Filed: **Dec. 31, 2015**

Related U.S. Application Data

(62) Division of application No. 29/474,660, filed on Dec. 18, 2014, now Pat. No. Des. 775,282.

* cited by examiner

Primary Examiner — Darlington Ly

(74) *Attorney, Agent, or Firm* — T D Paulius

(30) **Foreign Application Priority Data**

Jun. 20, 2014 (EM) 002487322
Dec. 9, 2014 (EM) 002593723

(57) **CLAIM**

The ornamental design for a vehicle frame, as shown and described.

(51) **LOC (10) Cl.** **21-01**

DESCRIPTION

(52) **U.S. Cl.**
USPC **D21/426; D12/87**

FIG. 1 is a front, top and left perspective view of a vehicle frame showing our new design;
FIG. 2 is a rear, bottom and right perspective view thereof;
FIG. 3 is a front elevation view thereof;
FIG. 4 is a rear elevation view thereof;
FIG. 5 is a right side elevation view thereof;
FIG. 6 is a left side elevation view thereof;
FIG. 7 is a top plan view thereof; and,
FIG. 8 is a bottom plan view thereof.

(58) **Field of Classification Search**
USPC D21/412, 414, 431-435; D12/1, 87, 107,
D12/110-114, 129, 130, 133; 280/87.01,
280/87.021, 87.05, 87.051, 47.17, 47.25,
280/47.34, 47.38, 47.4, 827, 828, 29, 200,
280/263, 266, 267, 270, 282, 288.4, 291,
280/293; 297/5; 482/68
CPC A63G 25/00; B62D 21/183; B62D 39/00;
B60K 7/0007

See application file for complete search history.

1 Claim, 8 Drawing Sheets

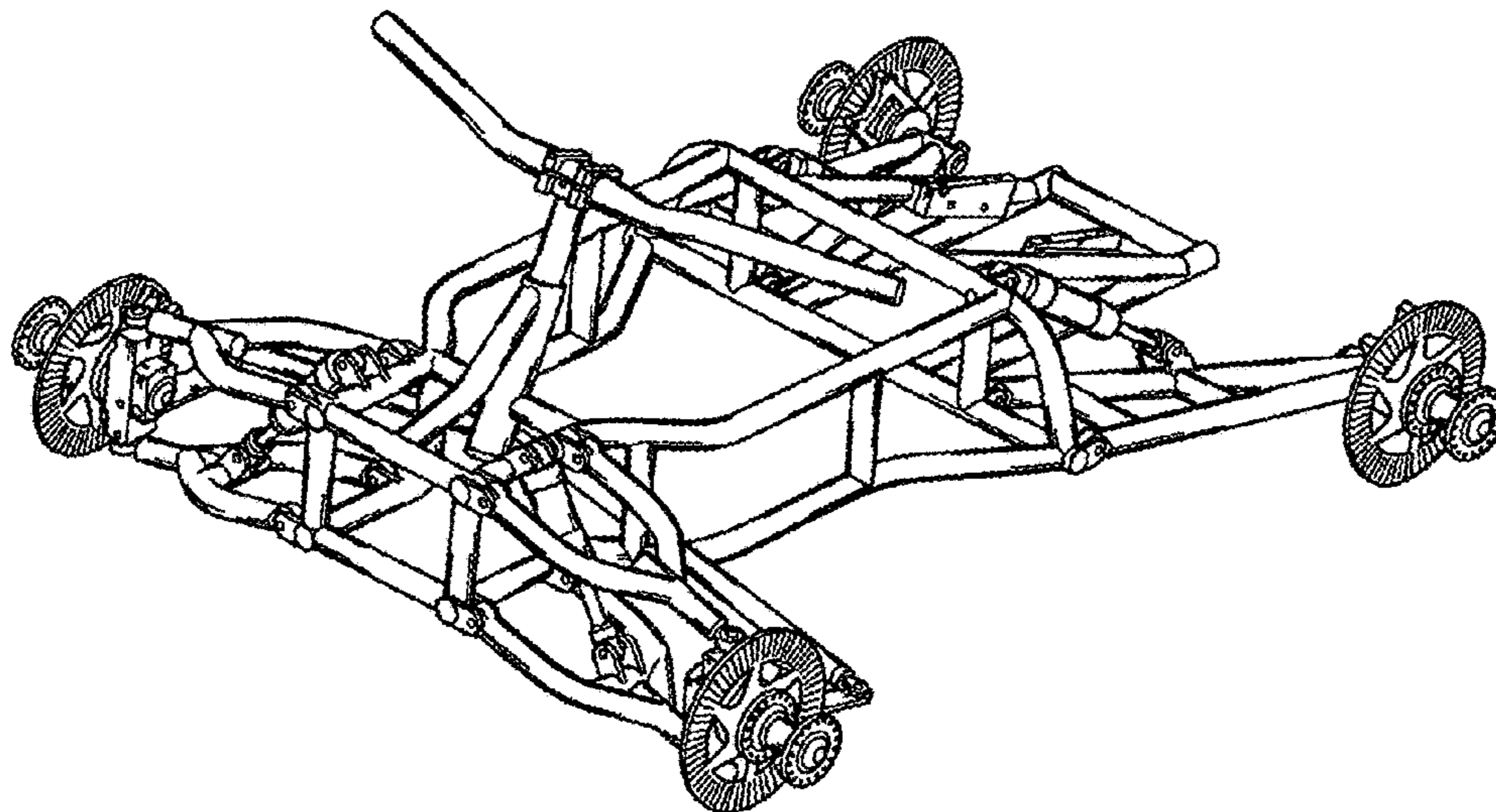

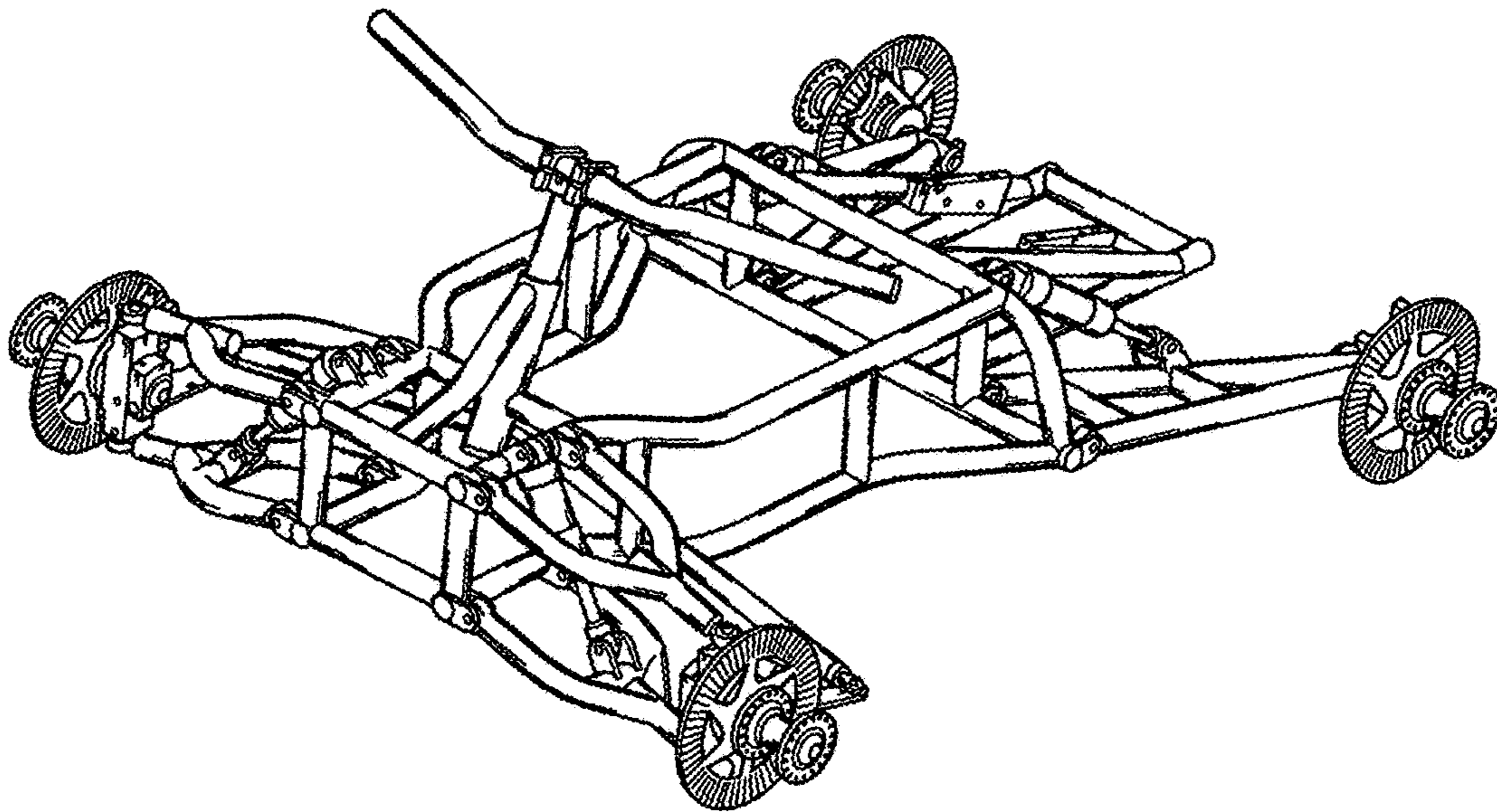

FIG. 1

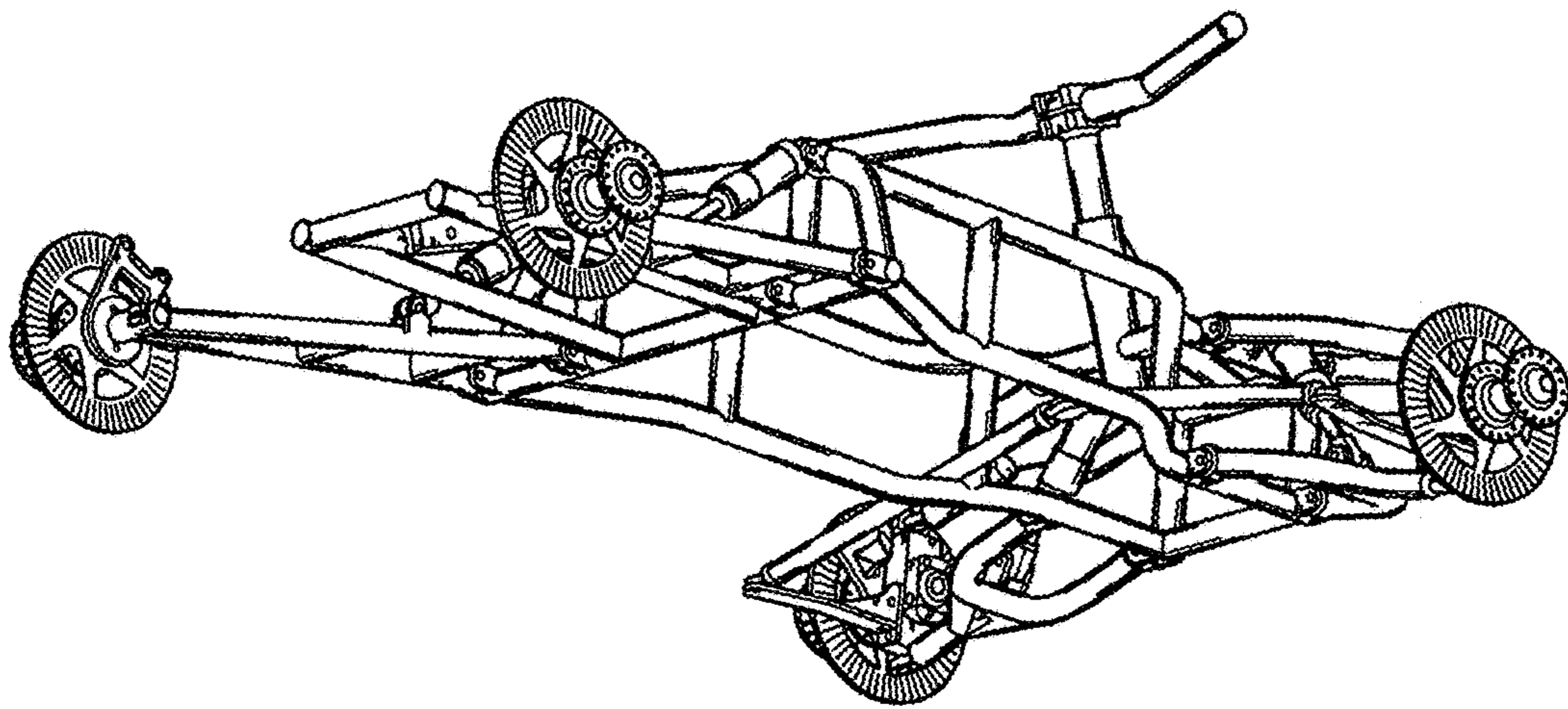

FIG. 2

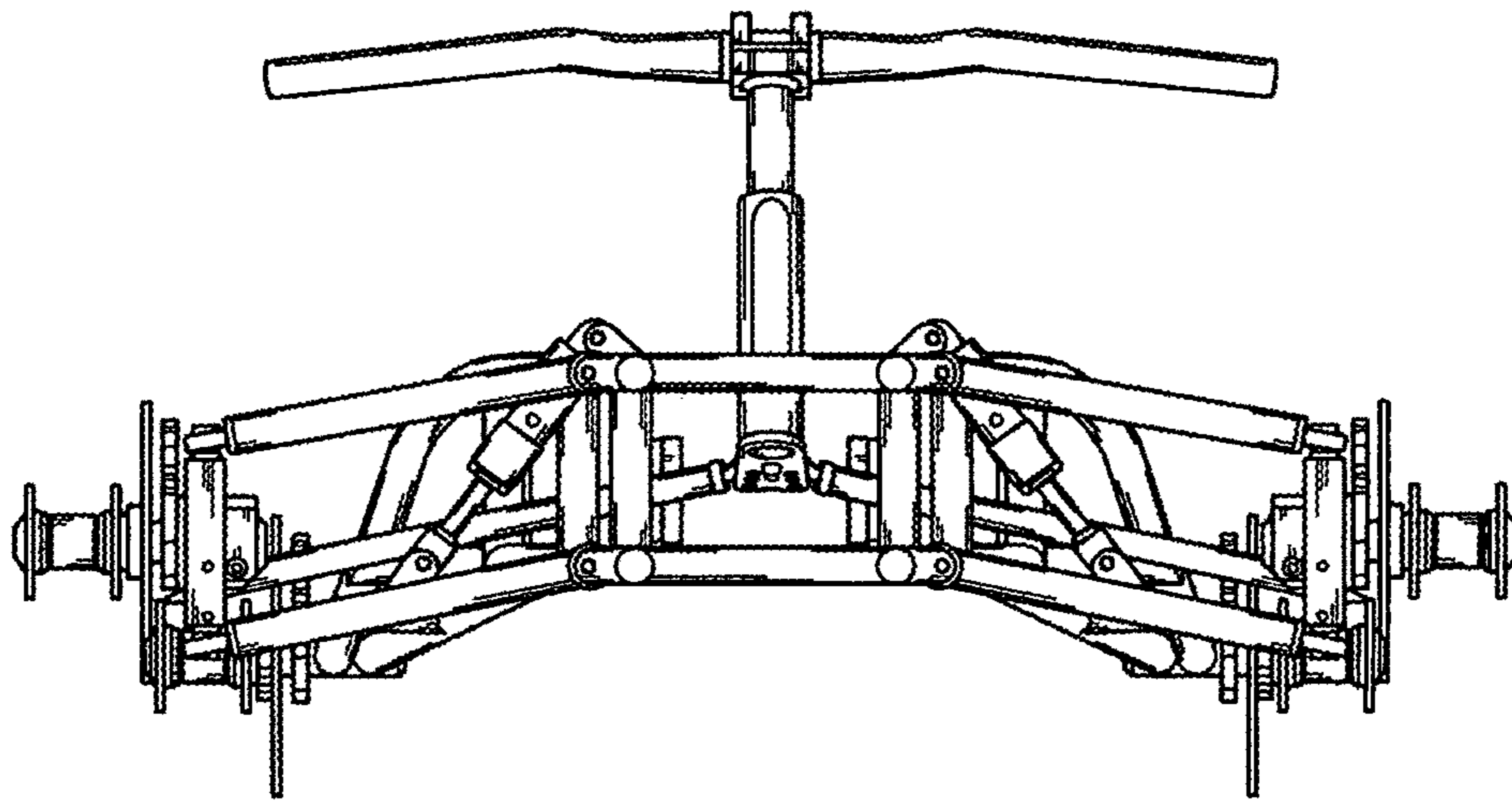

FIG. 3

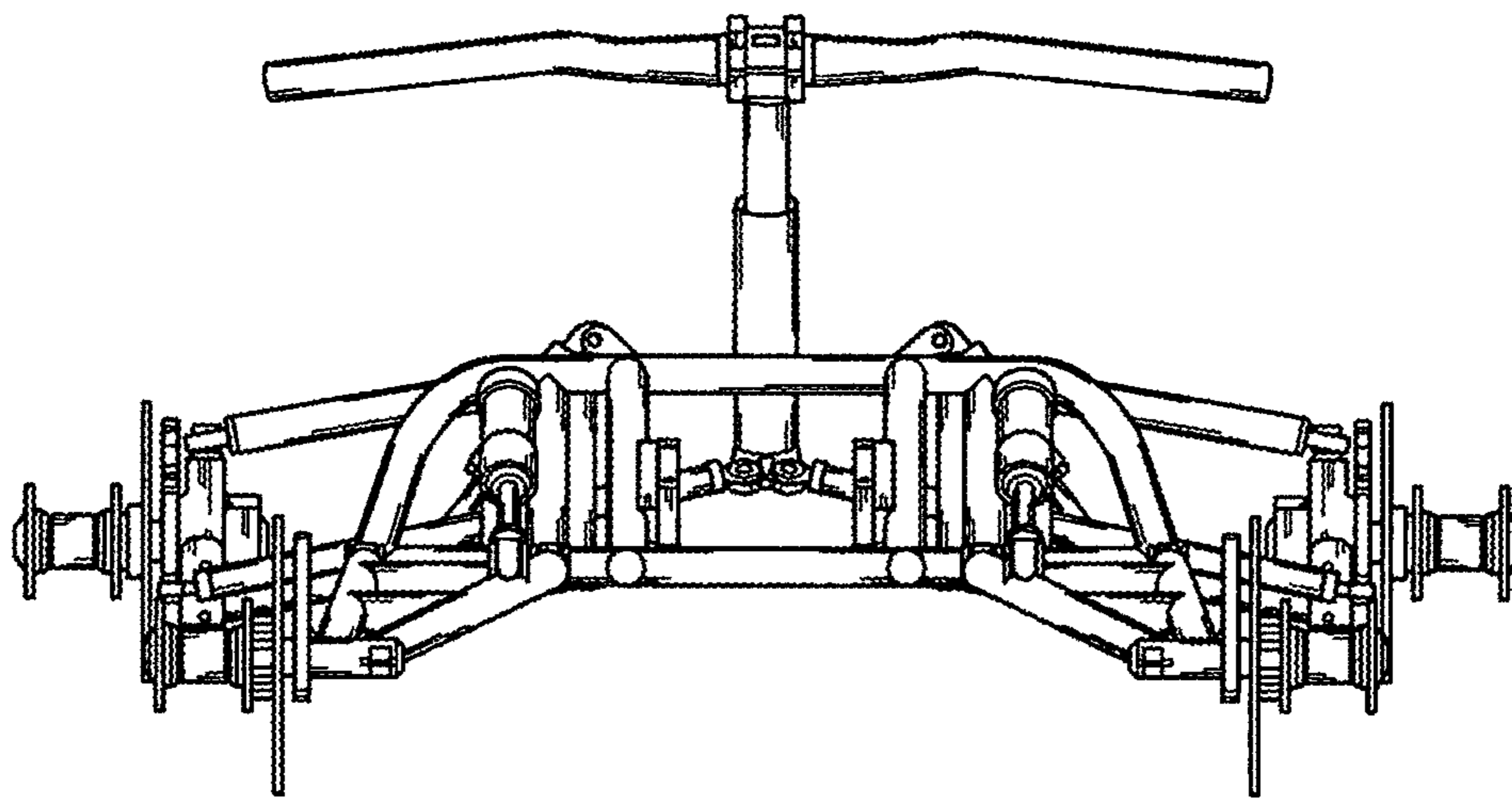

FIG. 4

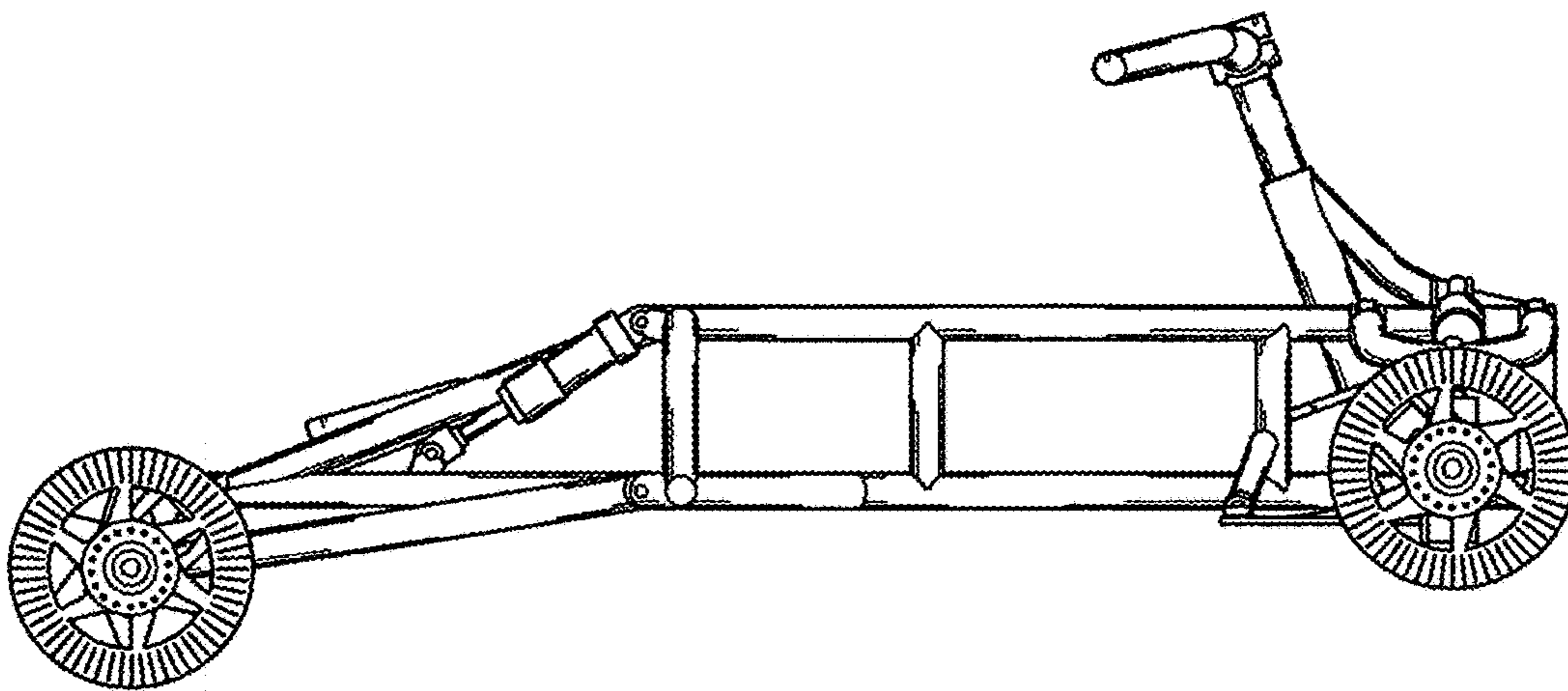

FIG. 5

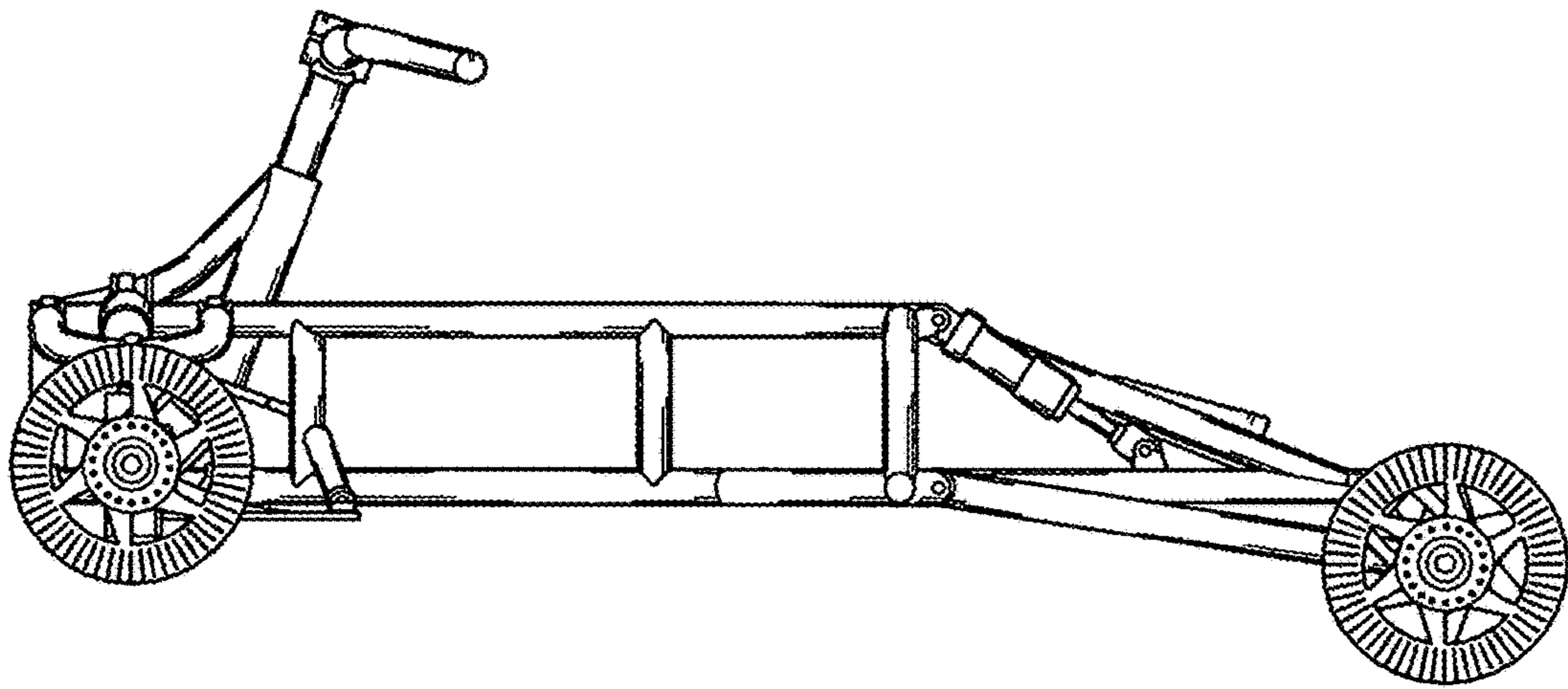

FIG. 6

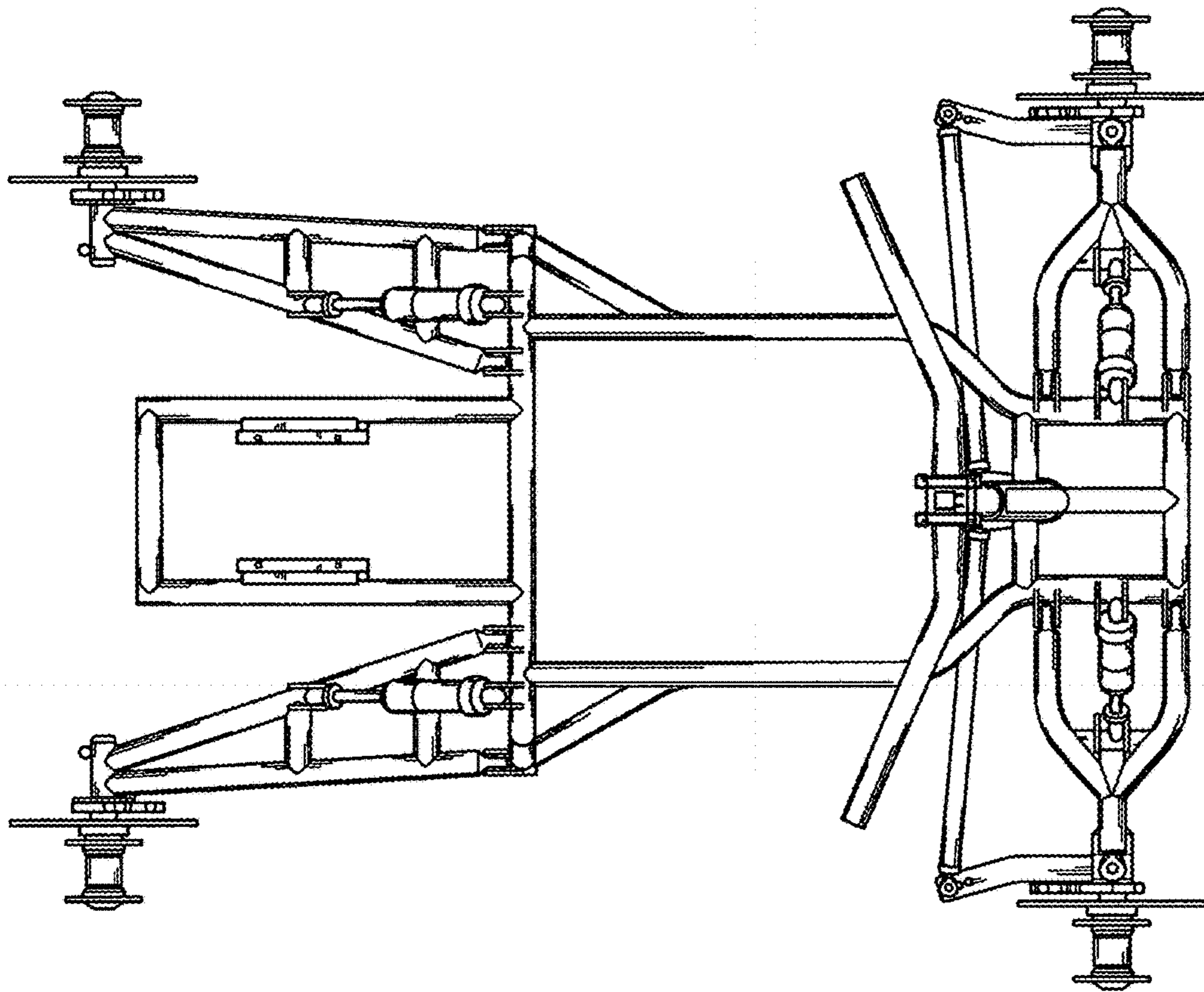

FIG. 7

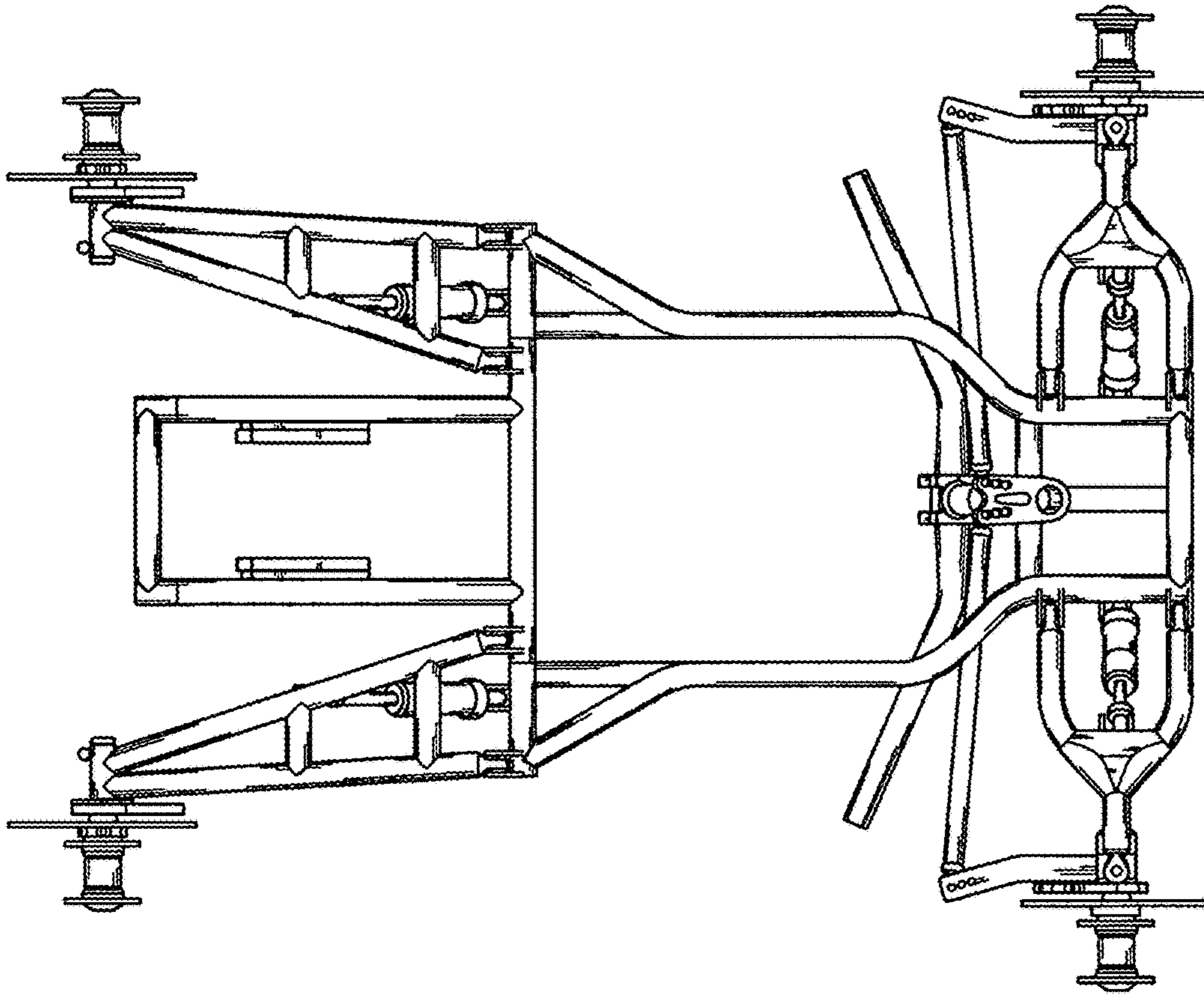

FIG. 8