



US00D783543S

(12) **United States Design Patent**
Sims et al.

(10) **Patent No.:** **US D783,543 S**

(45) **Date of Patent:** **** Apr. 11, 2017**

(54) **ACTUATOR MODULE FOR AN ELECTRIC STRIKE ASSEMBLY**

(71) Applicant: **Hanchett Entry Systems, Inc.**,
Phoenix, AZ (US)

(72) Inventors: **Ryan Matthew Sims**, Mesa, AZ (US);
Baruch Spence, Phoenix, AZ (US);
Michael Allen Webb, Cave Creek, AZ (US)

(73) Assignee: **Hanchett Entry Systems, Inc.**,
Phoenix, AZ (US)

(**) Term: **14 Years**

(21) Appl. No.: **29/523,858**

(22) Filed: **Apr. 14, 2015**

(51) **LOC (10) Cl.** **13-03**

(52) **U.S. Cl.**
USPC **D13/158**

(58) **Field of Classification Search**
USPC D13/158, 160, 170, 174
CPC E05B 15/02; E05B 15/0205; E05B 15/024;
H01H 23/163; H01H 15/04; H01H 15/06
See application file for complete search history.

(56) **References Cited**

U.S. PATENT DOCUMENTS

3,786,206	A *	1/1974	Kurimsky	H01H 13/702
					200/16 D
3,857,000	A *	12/1974	Boulanger	H01H 15/24
					200/16 D
4,016,378	A *	4/1977	Arthur	H01H 15/06
					200/16 D
D255,030	S *	5/1980	Holce	D13/158
D286,769	S *	11/1986	Gepner	D13/158

D325,376	S *	4/1992	Krasser	D13/158
5,875,884	A *	3/1999	Tomotoshi	H01H 15/06
					200/16 R
6,333,479	B1 *	12/2001	Tai	H01H 15/005
					200/16 D
6,774,329	B2 *	8/2004	Shimizu	H01H 23/164
					200/329
6,864,454	B2 *	3/2005	Shimizu	H01H 15/102
					200/563
D520,958	S *	5/2006	Yoneyama	D13/158
D534,500	S *	1/2007	Yamada	D13/158
D548,701	S *	8/2007	Hashimoto	D13/160
D626,921	S *	11/2010	Pang	D13/158
8,466,384	B2 *	6/2013	Villain	H01H 15/005
					200/550
8,748,765	B2 *	6/2014	Kokubu	H01H 1/44
					200/178

(Continued)

Primary Examiner — Selina Sikder

(74) *Attorney, Agent, or Firm* — Woods Oviatt Gilman, LLP; Ronald J. Kisicki, Esq.

(57) **CLAIM**

The ornamental design for the actuator module for an electric strike assembly, as shown and described.

DESCRIPTION

FIG. 1 is a front right perspective view of an actuator module for an electric strike assembly of our new design; FIG. 2 is a front view thereof; FIG. 3 is a top view thereof; FIG. 4 is a back view thereof; FIG. 5 is a bottom view thereof; and, FIG. 6 is a left side view thereof with the right side view being a mirror image thereof. The portions of the drawings shown in broken lines form no part of the claimed design.

1 Claim, 2 Drawing Sheets

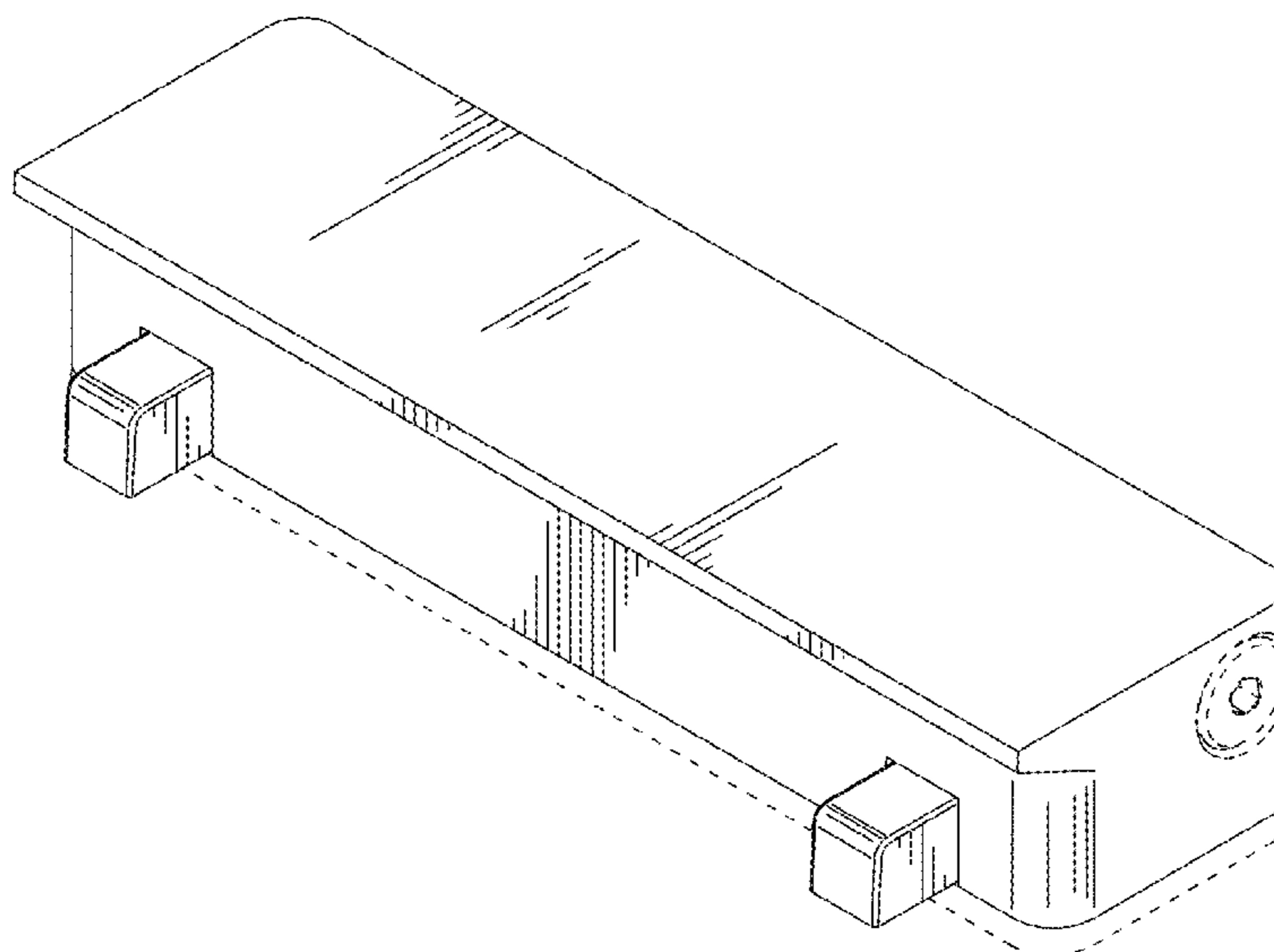

(56)

References Cited

U.S. PATENT DOCUMENTS

2005/0034964 A1* 2/2005 Zhou H01H 23/164
200/252
2016/0305157 A1* 10/2016 Sims E05B 15/024

* cited by examiner

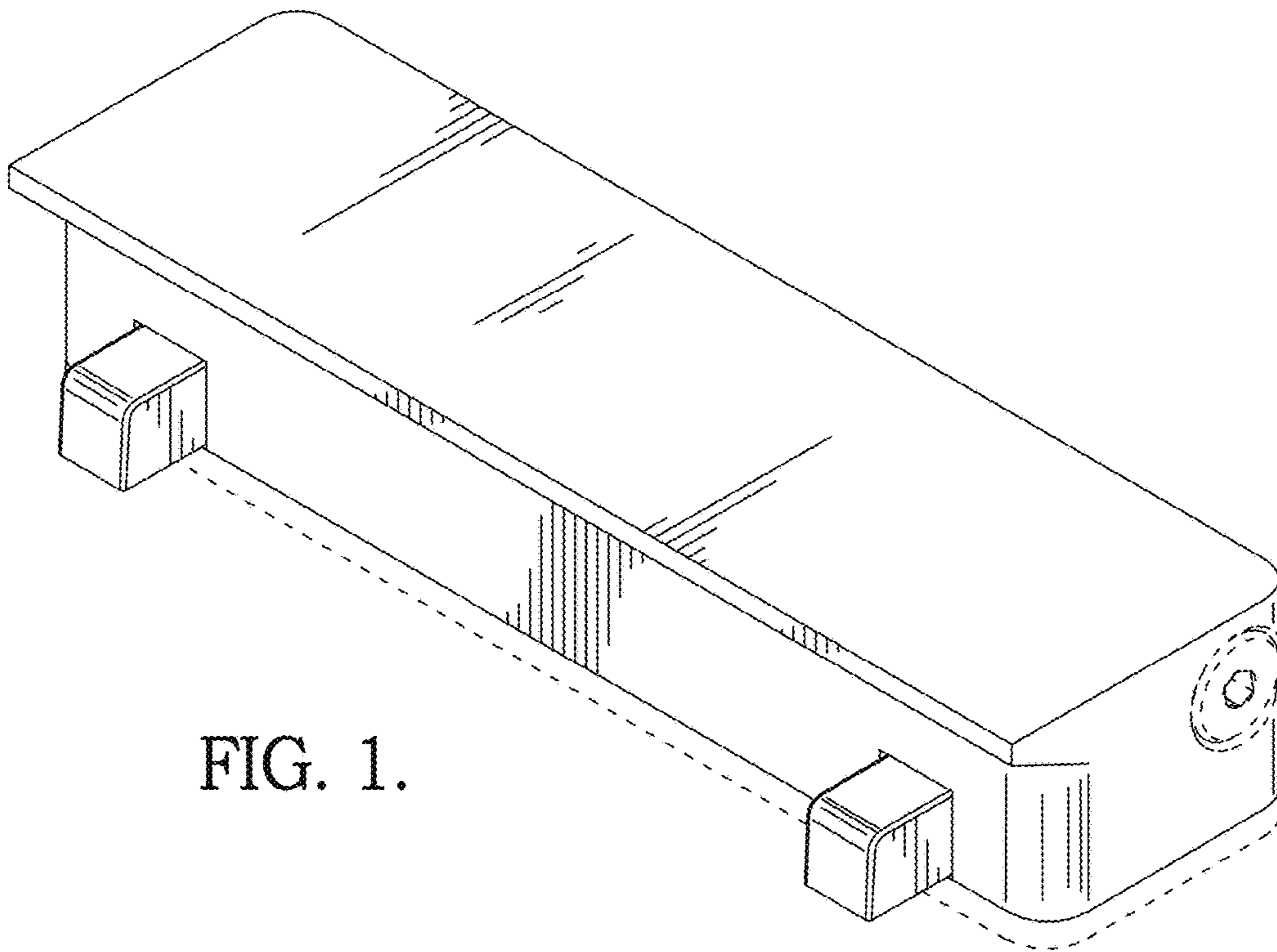

FIG. 1.

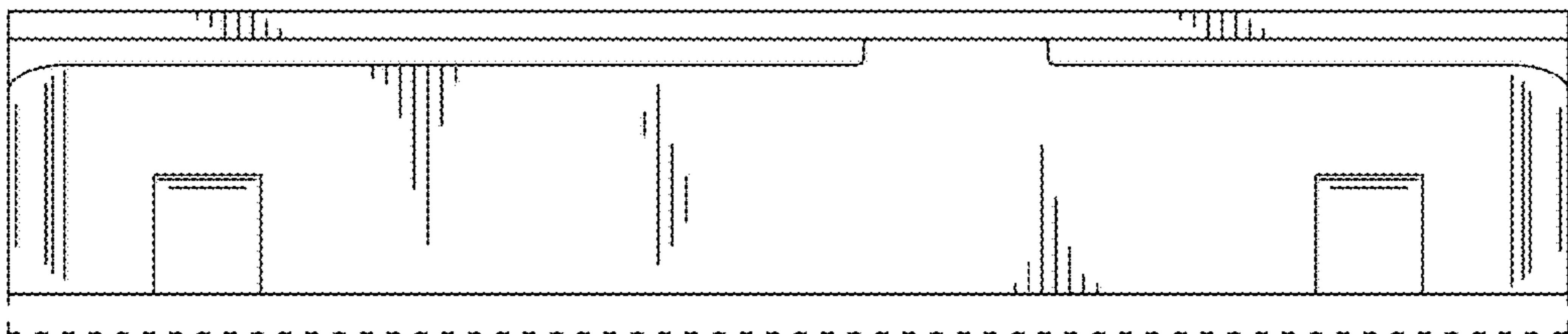

FIG. 2.

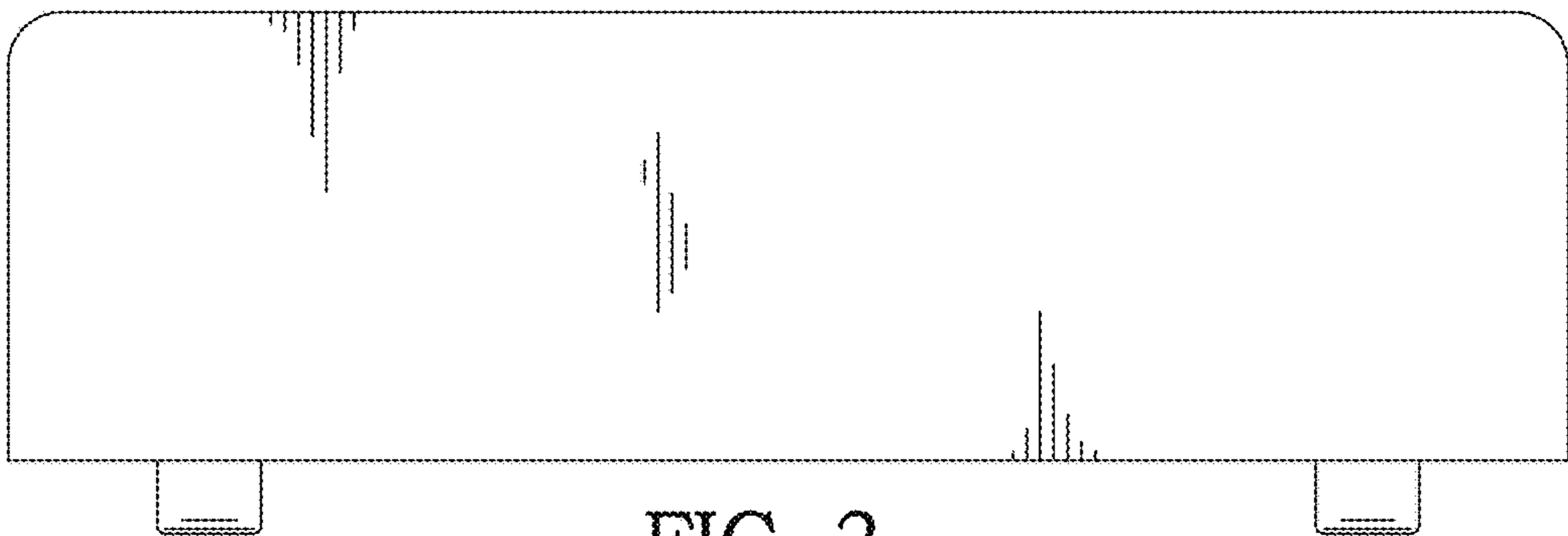

FIG. 3.

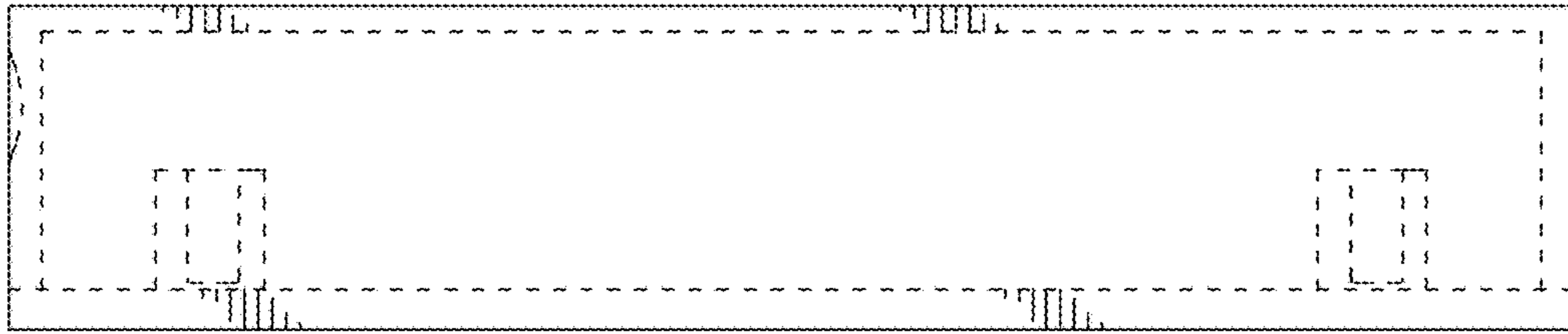

FIG. 4.

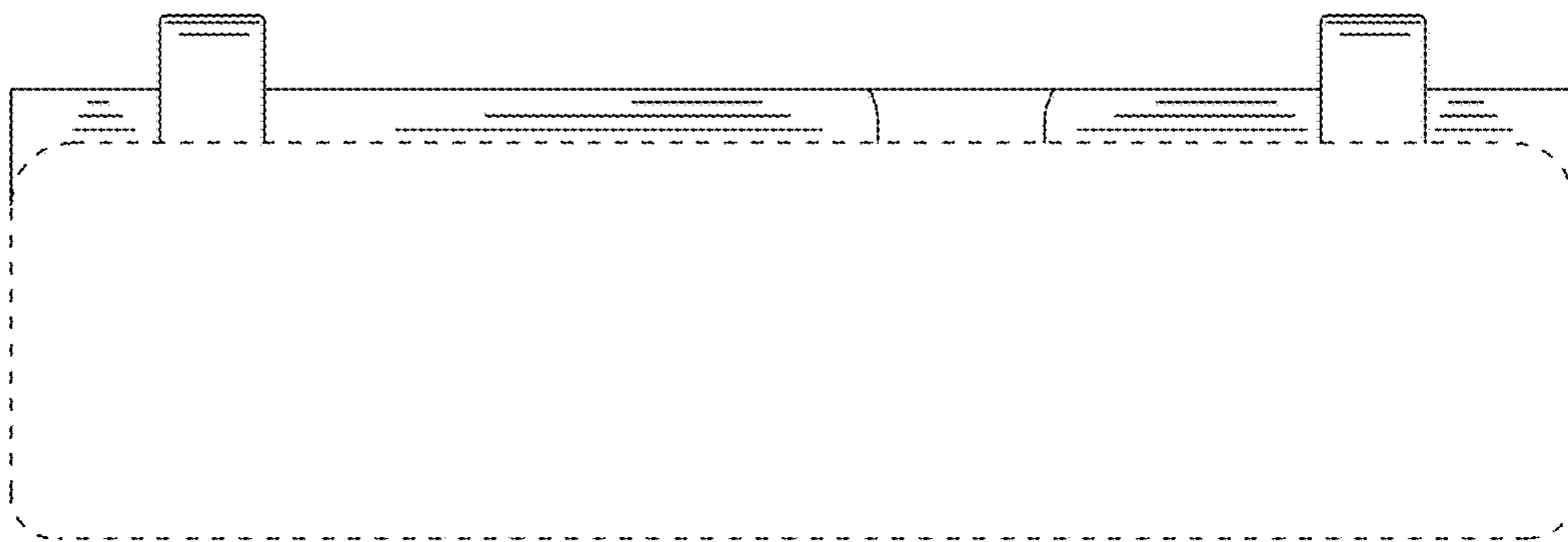

FIG. 5.

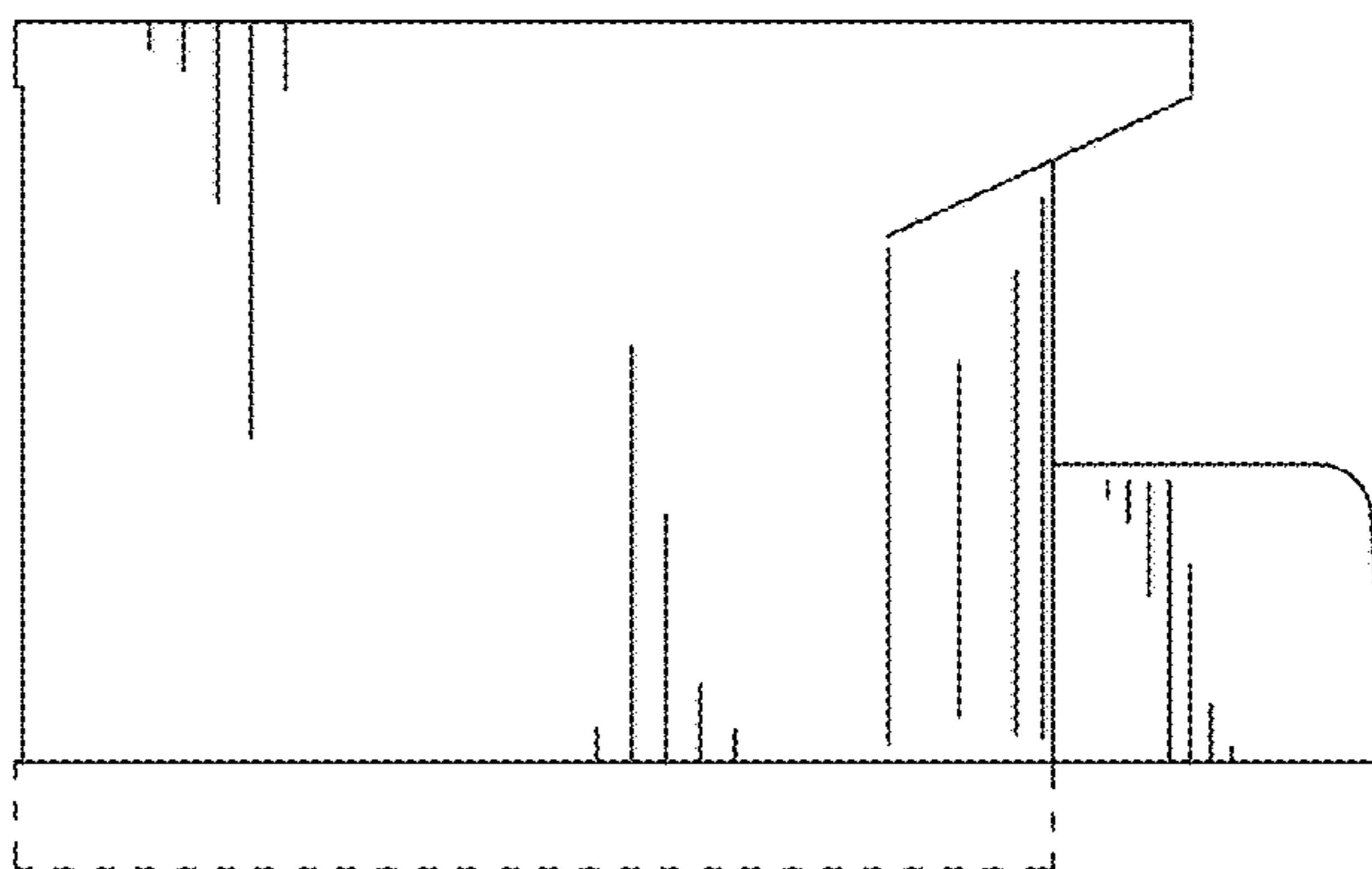

FIG. 6.