



US00D783188S

(12) **United States Design Patent** (10) **Patent No.:** **US D783,188 S**  
**Espejo** (45) **Date of Patent:** **\*\* Apr. 4, 2017**

(54) **BICYCLE HEADLIGHT**

(71) Applicant: **EarthSpirits Net Inc.**, Rockaway, NJ  
(US)

(72) Inventor: **Michael Espejo**, Morris Plains, NJ  
(US)

(73) Assignee: **EarthSpirits Net Inc.**, Rockaway, NJ  
(US)

(\*\*) Term: **15 Years**

(21) Appl. No.: **29/533,275**

(22) Filed: **Jul. 15, 2015**

(51) **LOC (10) Cl.** ..... **26-07**

(52) **U.S. Cl.**  
USPC ..... **D26/28**

(58) **Field of Classification Search**  
USPC ..... D26/28-36; 362/459-468, 475-478,  
362/485-487  
CPC ..... F21S 48/00; F21S 48/10; F21S 48/115;  
F21S 48/225; F21S 48/1233; F21S  
48/1266; F21S 48/1388; F21S 48/2268;  
F21V 21/04  
See application file for complete search history.

(56) **References Cited**

U.S. PATENT DOCUMENTS

- D597,237 S \* 7/2009 Kumthampinij ..... D26/28
- D629,539 S \* 12/2010 Rettenbacher ..... D26/28
- D663,453 S \* 7/2012 Nagano ..... D26/28
- D678,562 S \* 3/2013 Chan ..... D26/28
- D706,468 S \* 6/2014 Nagano ..... D26/28

- D709,222 S \* 7/2014 Poon ..... D26/28
- D715,980 S \* 10/2014 Ueda ..... D26/28
- D717,979 S \* 11/2014 Ueda ..... D26/28
- D735,381 S \* 7/2015 Lee ..... D26/28
- D751,739 S \* 3/2016 Hamasaki ..... D26/28
- D759,859 S \* 6/2016 Ng ..... D26/28
- 2012/0218771 A1\* 8/2012 Yen ..... B62J 11/00  
362/473
- 2013/0301285 A1\* 11/2013 McCaslin ..... B62J 6/003  
362/473

\* cited by examiner

Primary Examiner — Angela J Lee

(74) Attorney, Agent, or Firm — Baker and Rannells, PA

(57) **CLAIM**

The ornamental design for a bicycle headlight, as shown and described.

**DESCRIPTION**

FIG. 1 is an isometric view of a light in accordance with the new design;  
FIG. 2 is front elevational view thereof;  
FIG. 3 is a rear elevational view thereof;  
FIG. 4 is left side elevational view thereof;  
FIG. 5 is a right side elevational view thereof;  
FIG. 6 is a top plan elevational view thereof;  
FIG. 7 is a bottom plan elevational view thereof; and,  
FIG. 8 is a rear elevational view as shown in FIG. 3, showing an opened access port, which is shown closed in FIG. 3.  
Broken lines in figures are for illustrative purposes only and form no part of the design.

**1 Claim, 6 Drawing Sheets**

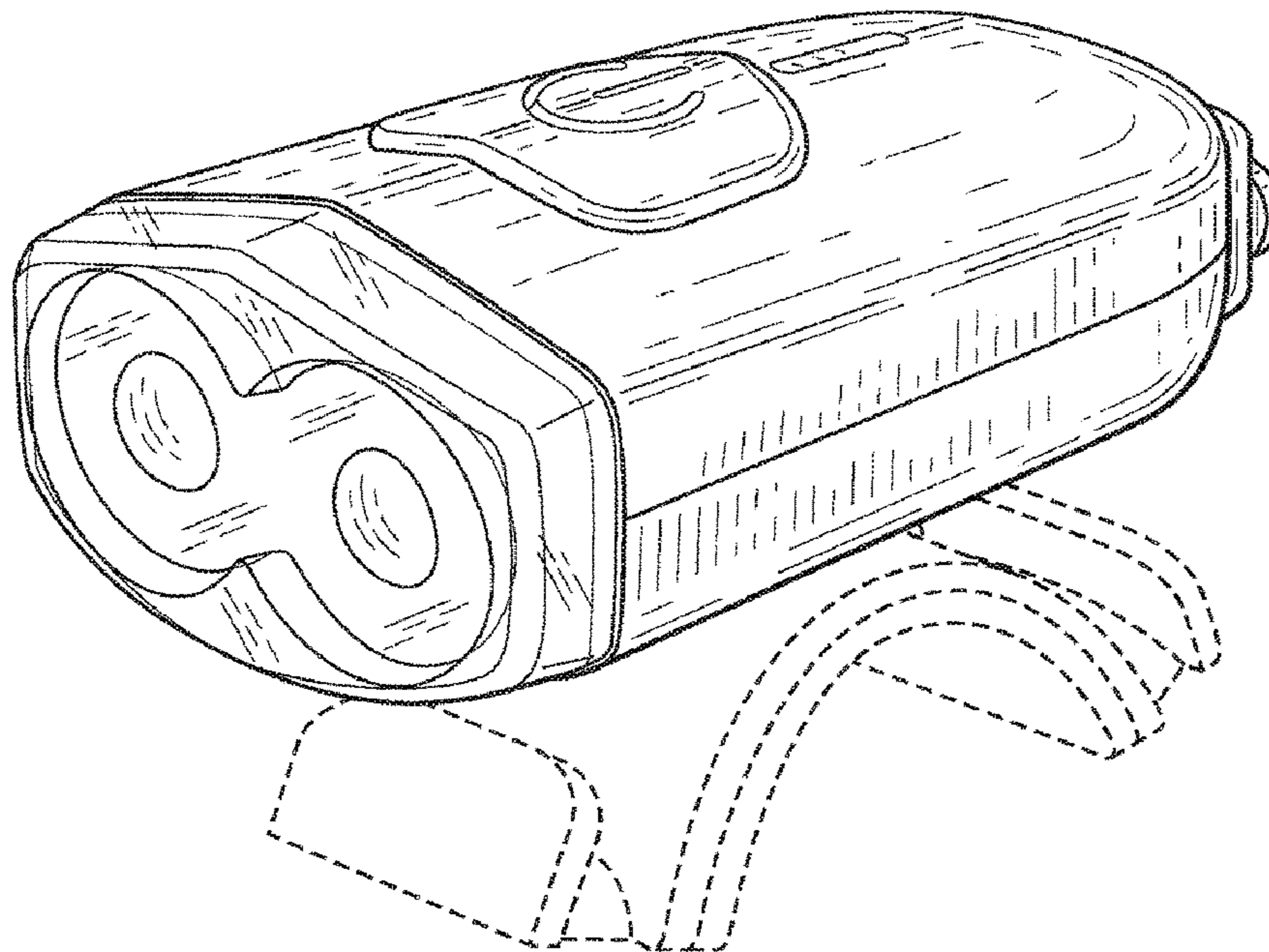

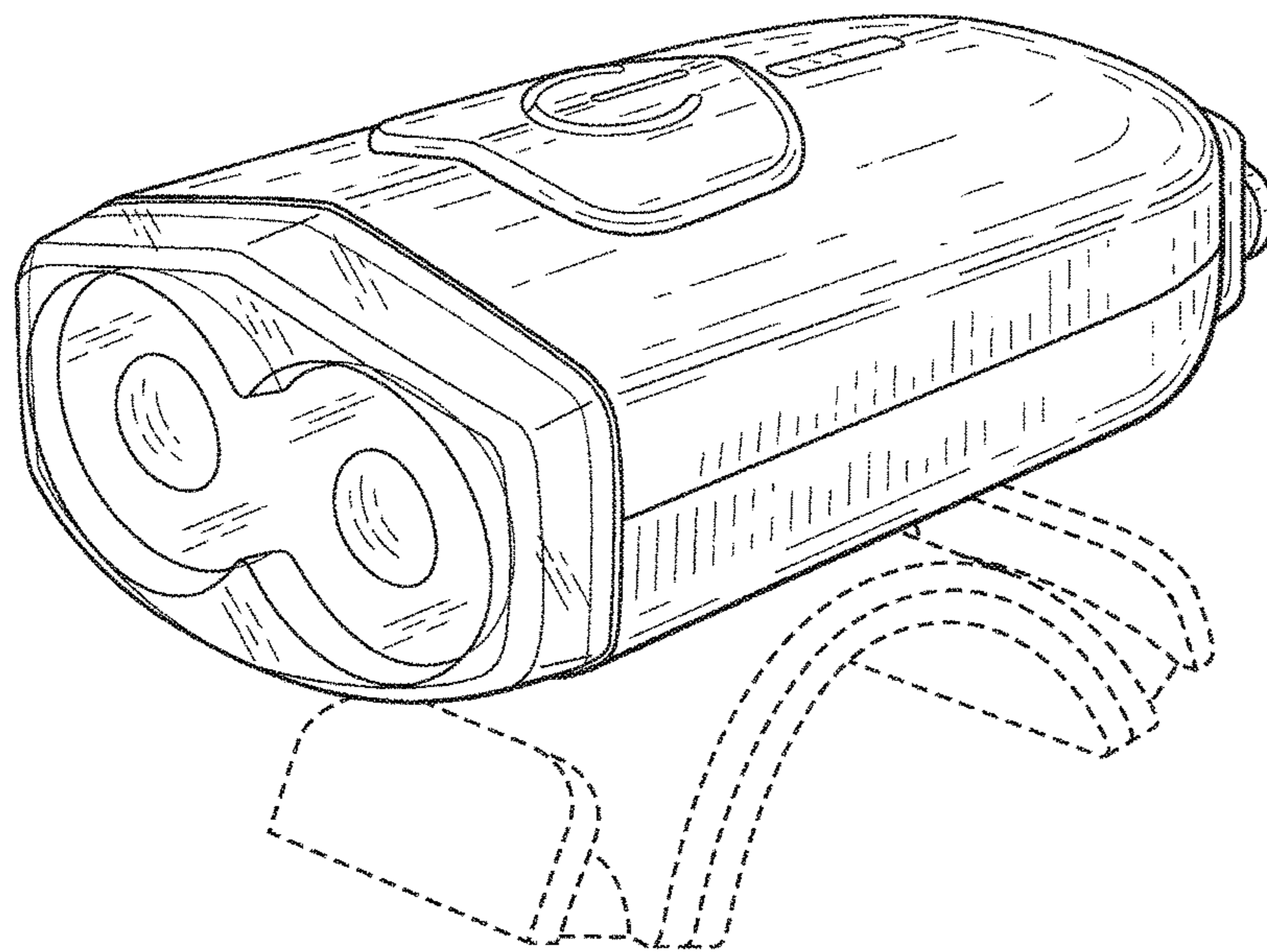

FIG. 1

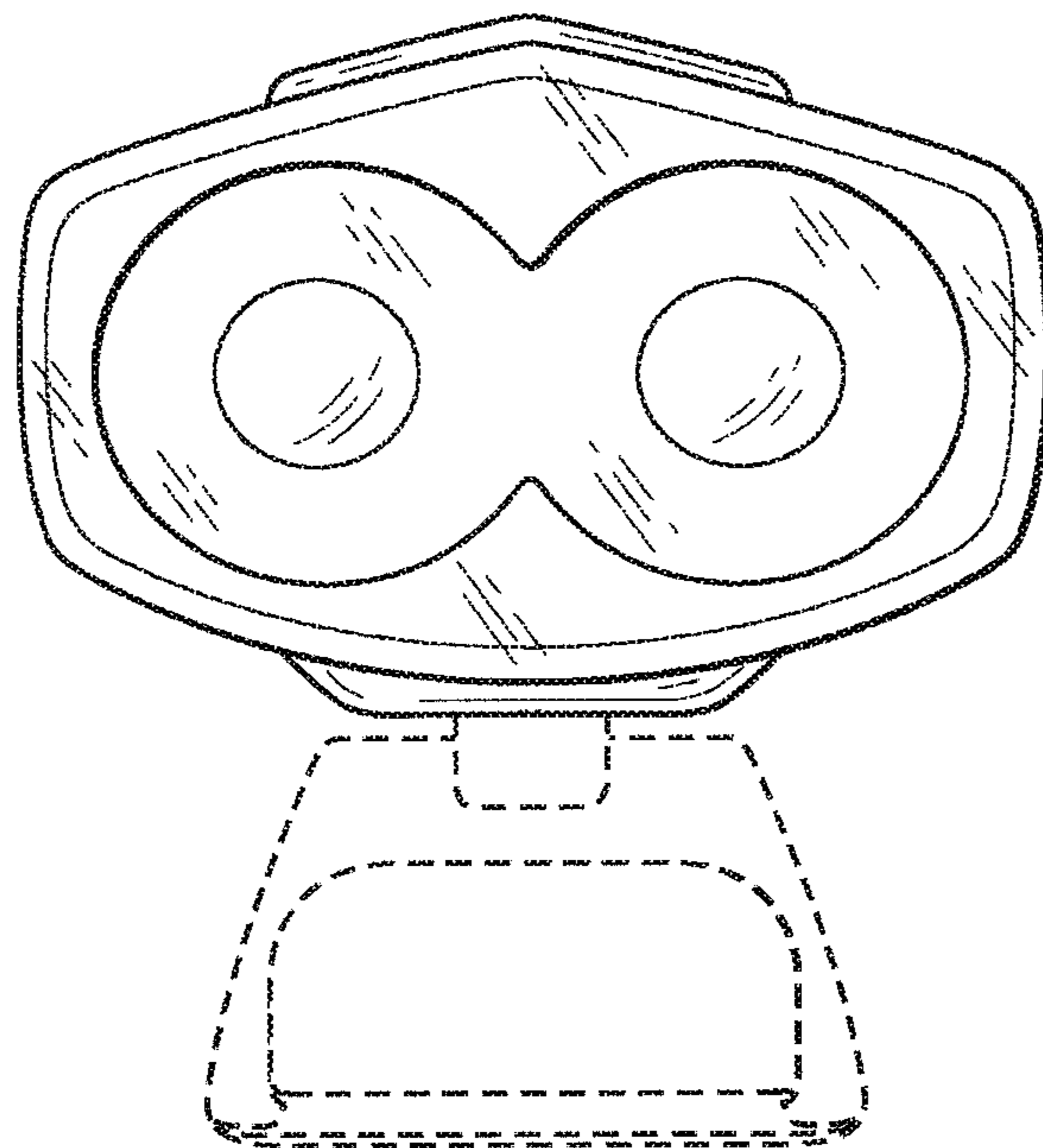

FIG. 2

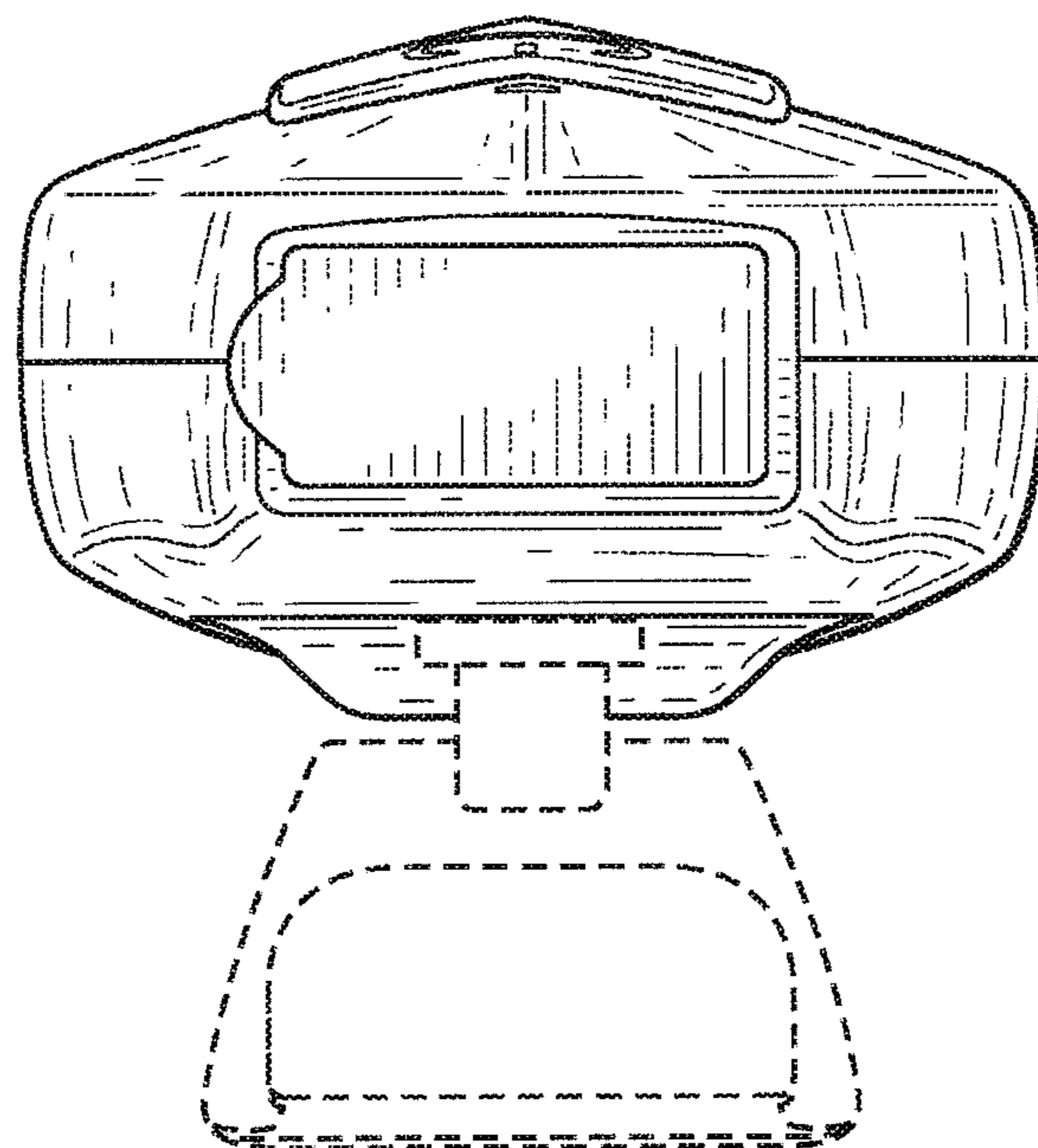

FIG. 3

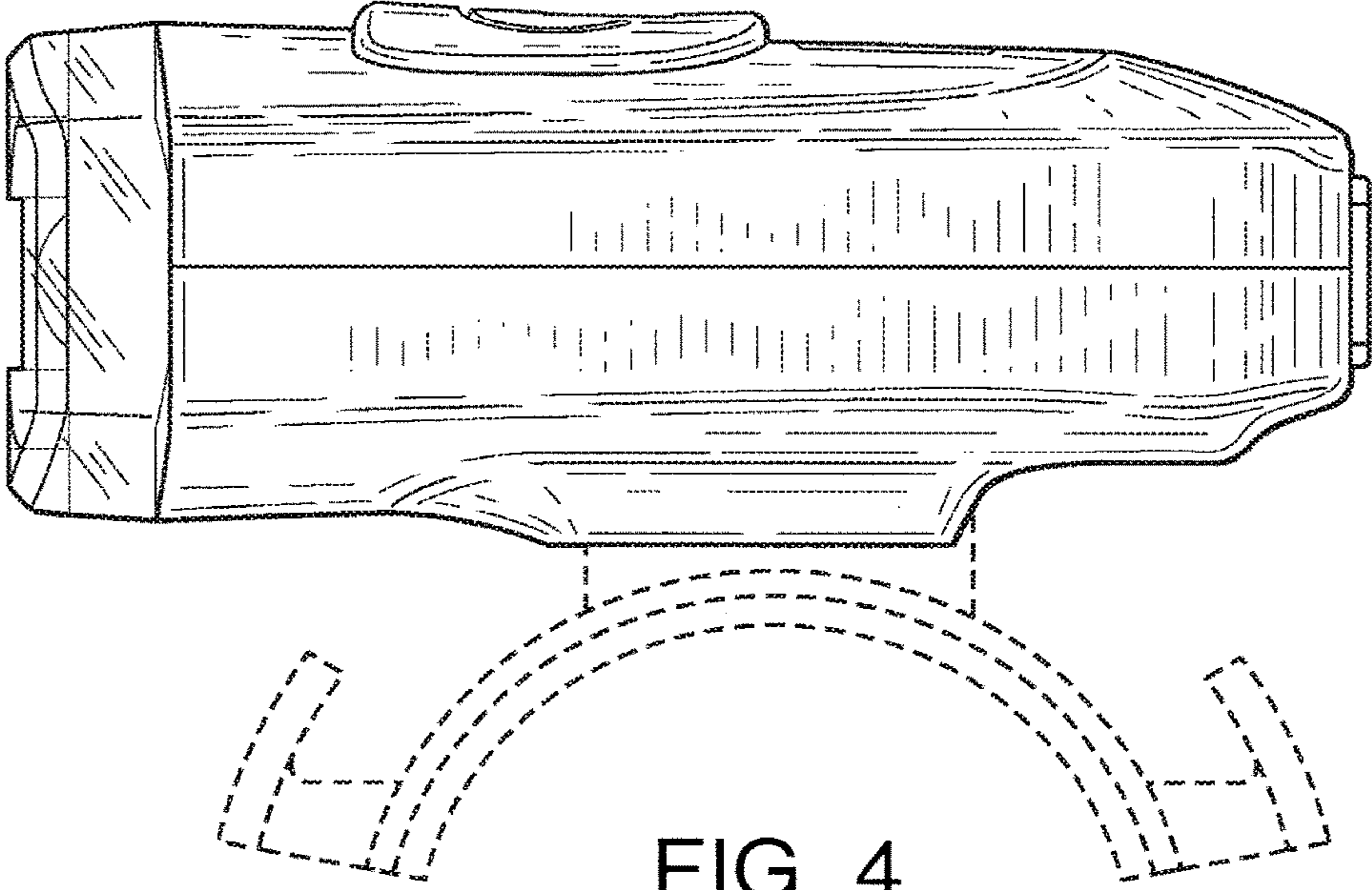

FIG. 4

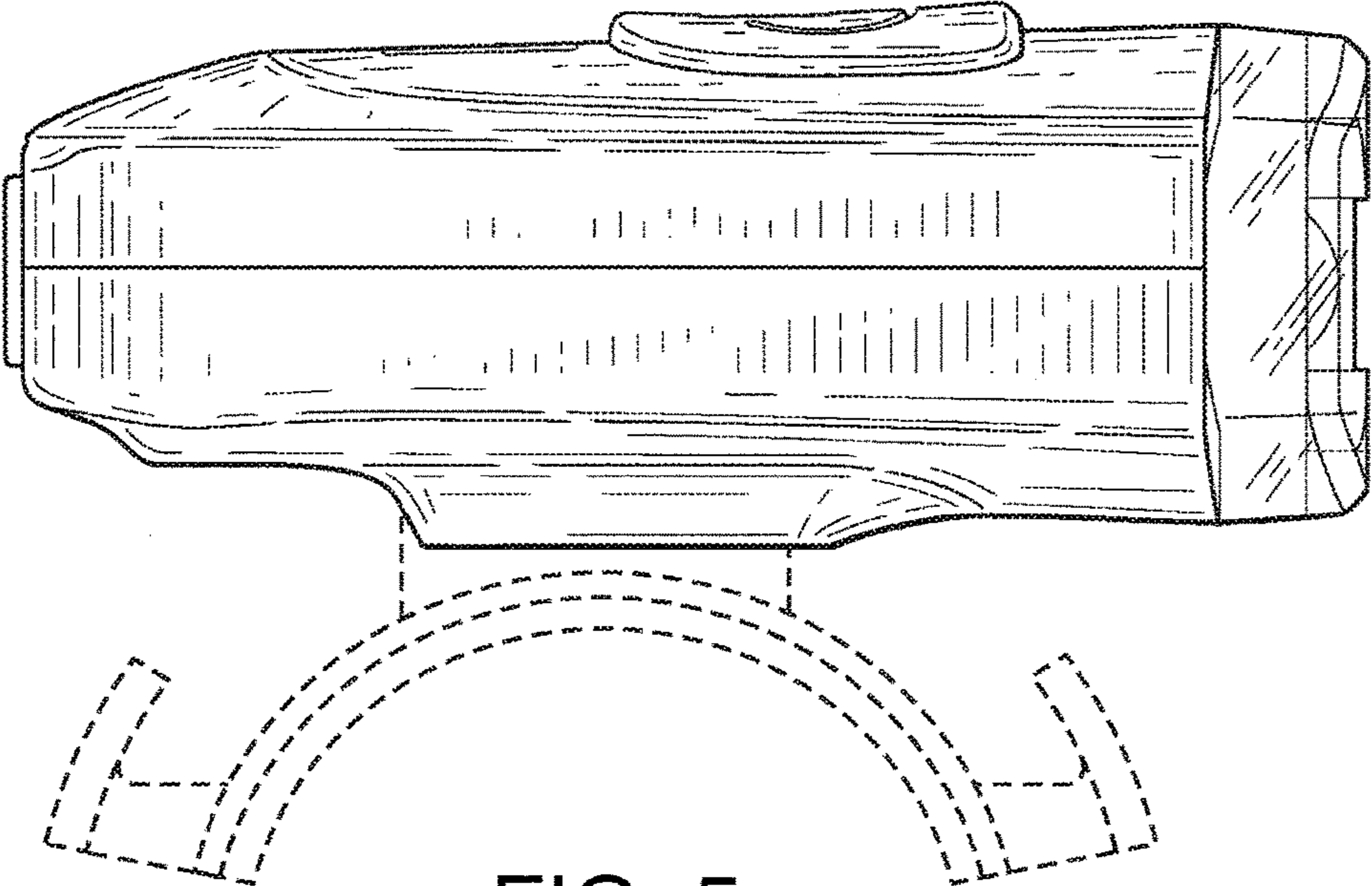

FIG. 5

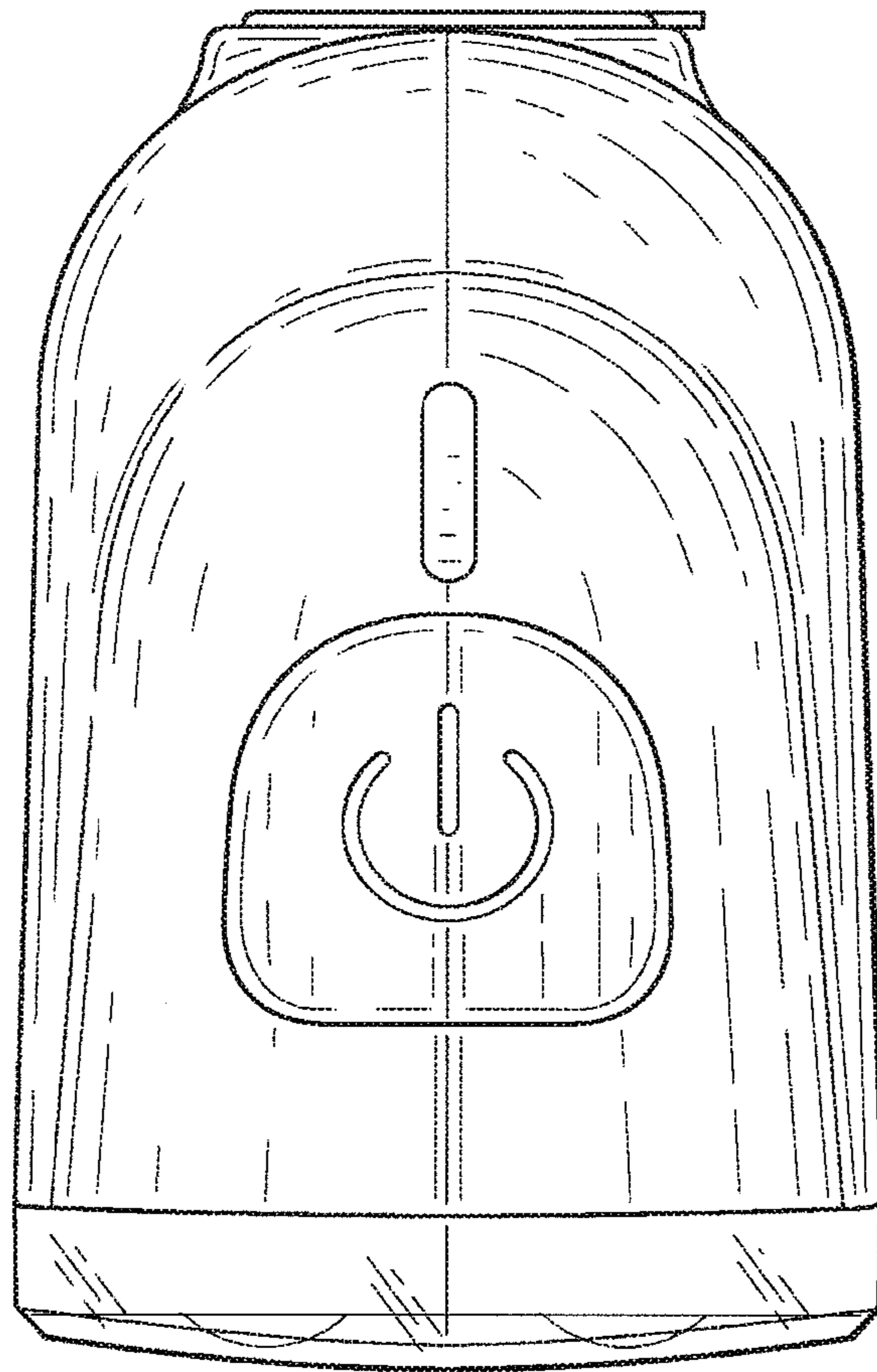

FIG. 6

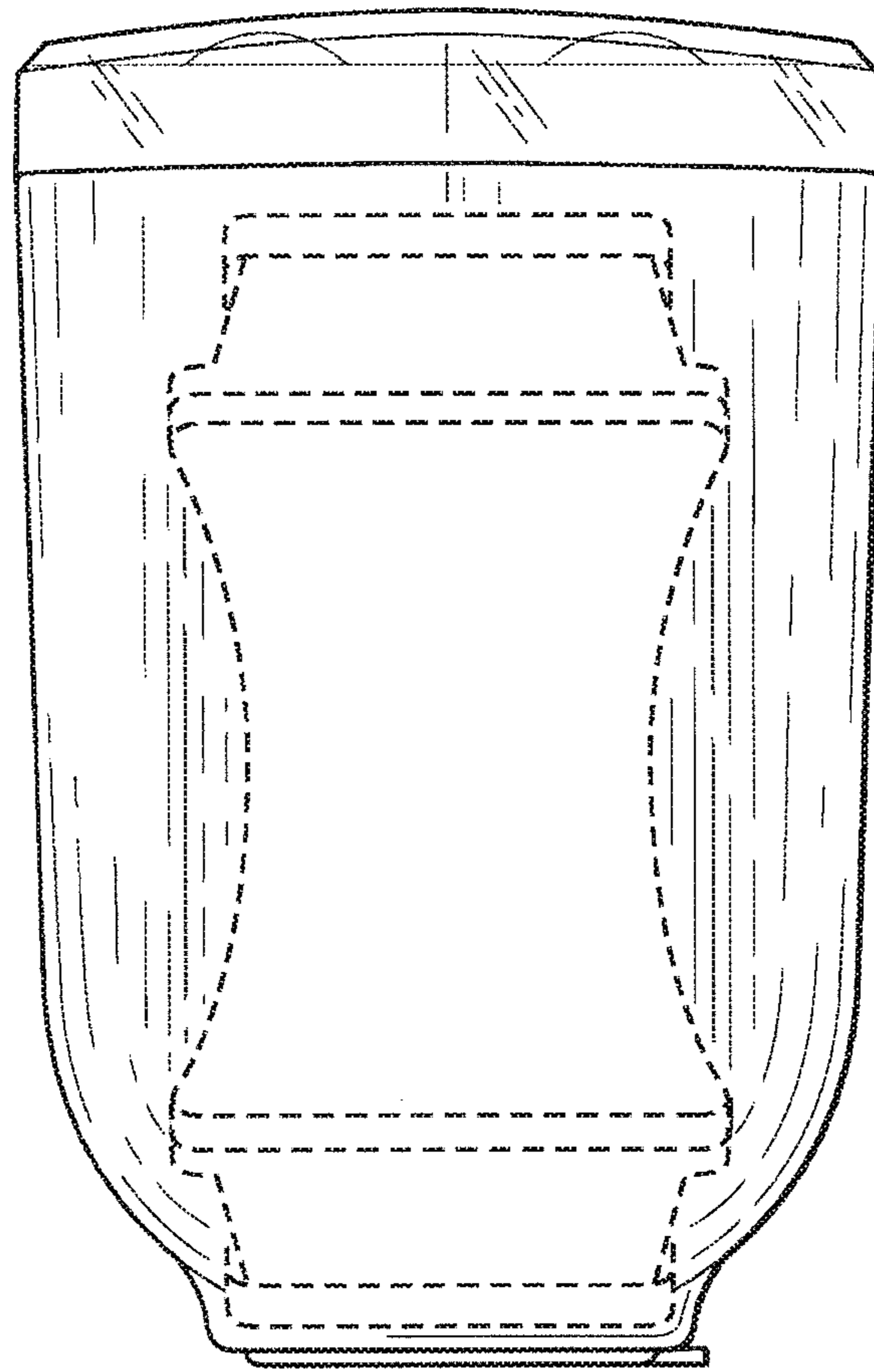

FIG. 7

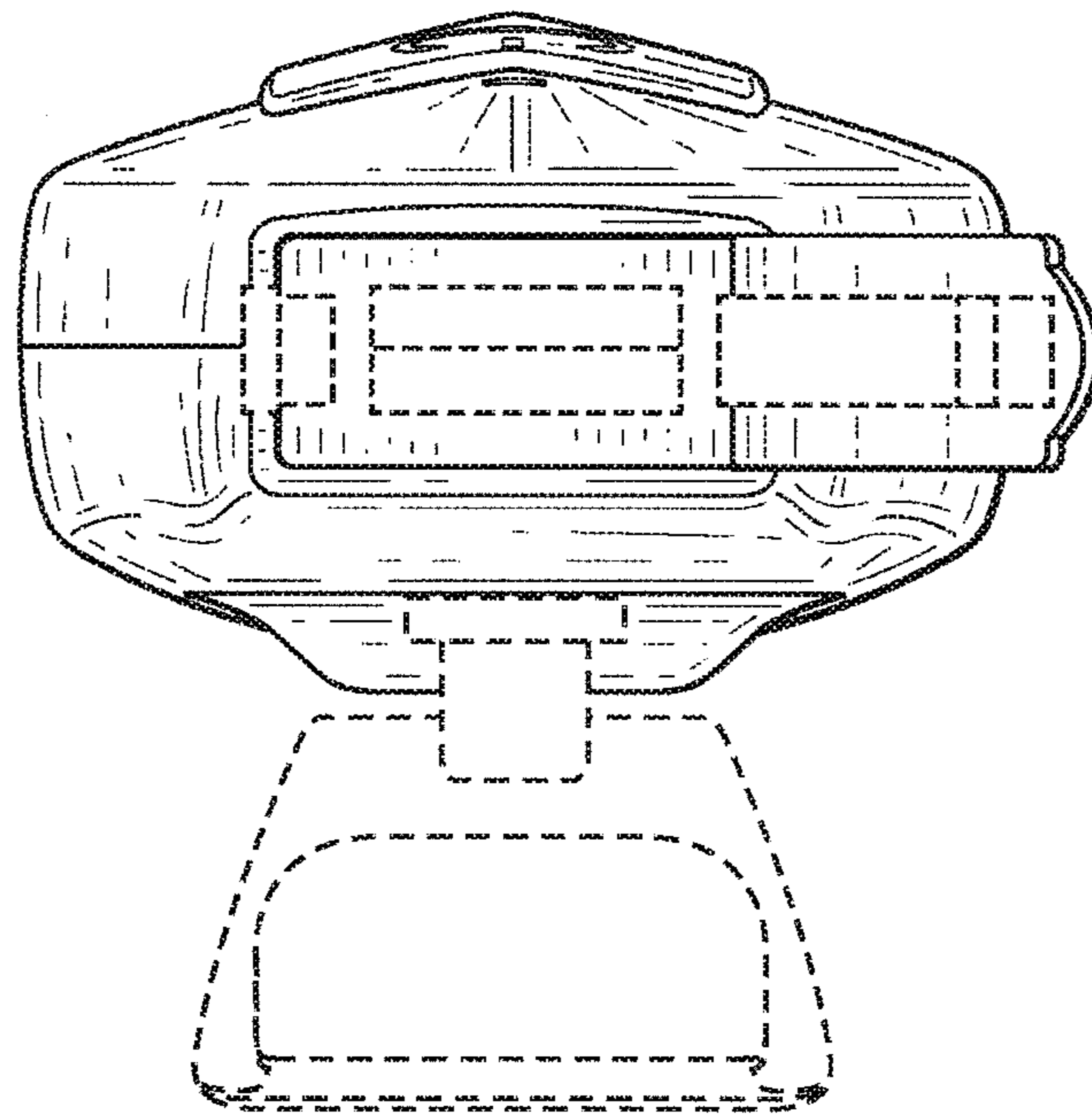

FIG. 8