



US00D782860S

(12) **United States Design Patent** (10) **Patent No.:** **US D782,860 S**  
**Toh** (45) **Date of Patent:** **\*\* \*Apr. 4, 2017**

(54) **SEAT ARM**  
(71) Applicant: **HTL International Holdings Ltd.,**  
Singapore (SG)  
(72) Inventor: **Chye Seng Toh,** Singapore (SG)  
(73) Assignee: **HTL International Holdings Ltd.,**  
Singapore (SG)  
(\* ) Notice: This patent is subject to a terminal disclaimer.  
(\*\* ) Term: **14 Years**  
(21) Appl. No.: **29/524,350**  
(22) Filed: **Apr. 20, 2015**  
(51) **LOC (10) Cl.** ..... **06-01**  
(52) **U.S. Cl.**  
USPC ..... **D6/717**  
(58) **Field of Classification Search**  
USPC ..... D6/334, 381, 708, 716.1, 716.2, 716.4,  
D6/717; 297/232, 233, 445.1, 446.1,  
297/448.1; 5/12.1, 12.2  
CPC ..... A47C 1/12; A47C 11/00; A47C 17/00;  
A47C 17/02  
See application file for complete search history.

D521,766 S \* 5/2006 Natuzzi ..... D6/381  
D527,198 S \* 8/2006 Nicoletti ..... D6/381  
D539,560 S \* 4/2007 Natuzzi ..... D6/381

(Continued)

*Primary Examiner* — Sandra Snapp  
(74) *Attorney, Agent, or Firm* — Maier & Maier, PLLC

(57) **CLAIM**

The ornamental design for a seat arm, as shown and described.

**DESCRIPTION**

FIG. 1 is a front perspective view of a seat arm with environment;  
FIG. 2 is a front elevation view thereof;  
FIG. 3 is a left side view thereof;  
FIG. 4 is a right side view thereof;  
FIG. 5 is a rear elevation view thereof;  
FIG. 6 is a top plan view thereof;  
FIG. 7 is a front perspective view of a seat arm with alternative environment;  
FIG. 8 is a front elevation view thereof;  
FIG. 9 is a left side view thereof;  
FIG. 10 is a right side view thereof;  
FIG. 11 is a rear elevation view thereof;  
FIG. 12 is a top plan view thereof;  
FIG. 13 is a front perspective view of a seat arm with a second alternative environment;  
FIG. 14 is a front elevation view thereof;  
FIG. 15 is a left side view thereof;  
FIG. 16 is a right side view thereof;  
FIG. 17 is a rear elevation view thereof; and,  
FIG. 18 is a top plan view thereof.  
The dashed broken lines showing of the seat in the Figures are for illustrative purposes only and form no part of the claimed design. The smaller, dotted broken lines are understood to represent stitching.

(56) **References Cited**  
U.S. PATENT DOCUMENTS  
D362,129 S \* 9/1995 Natuzzi ..... D6/334  
D382,722 S \* 8/1997 Natuzzi ..... D6/334  
D390,032 S \* 2/1998 Natuzzi ..... D6/334  
D419,328 S \* 1/2000 Natuzzi ..... D6/334  
D431,925 S \* 10/2000 Natuzzi ..... D6/334  
D473,394 S \* 4/2003 Natuzzi ..... D6/381  
D487,996 S \* 4/2004 Natuzzi ..... D6/381  
D489,914 S \* 5/2004 Ricci ..... D6/334  
D497,056 S \* 10/2004 Ricci ..... D6/334  
D510,819 S \* 10/2005 Ricci ..... D6/381  
D521,268 S \* 5/2006 Natuzzi ..... D6/381

**1 Claim, 15 Drawing Sheets**

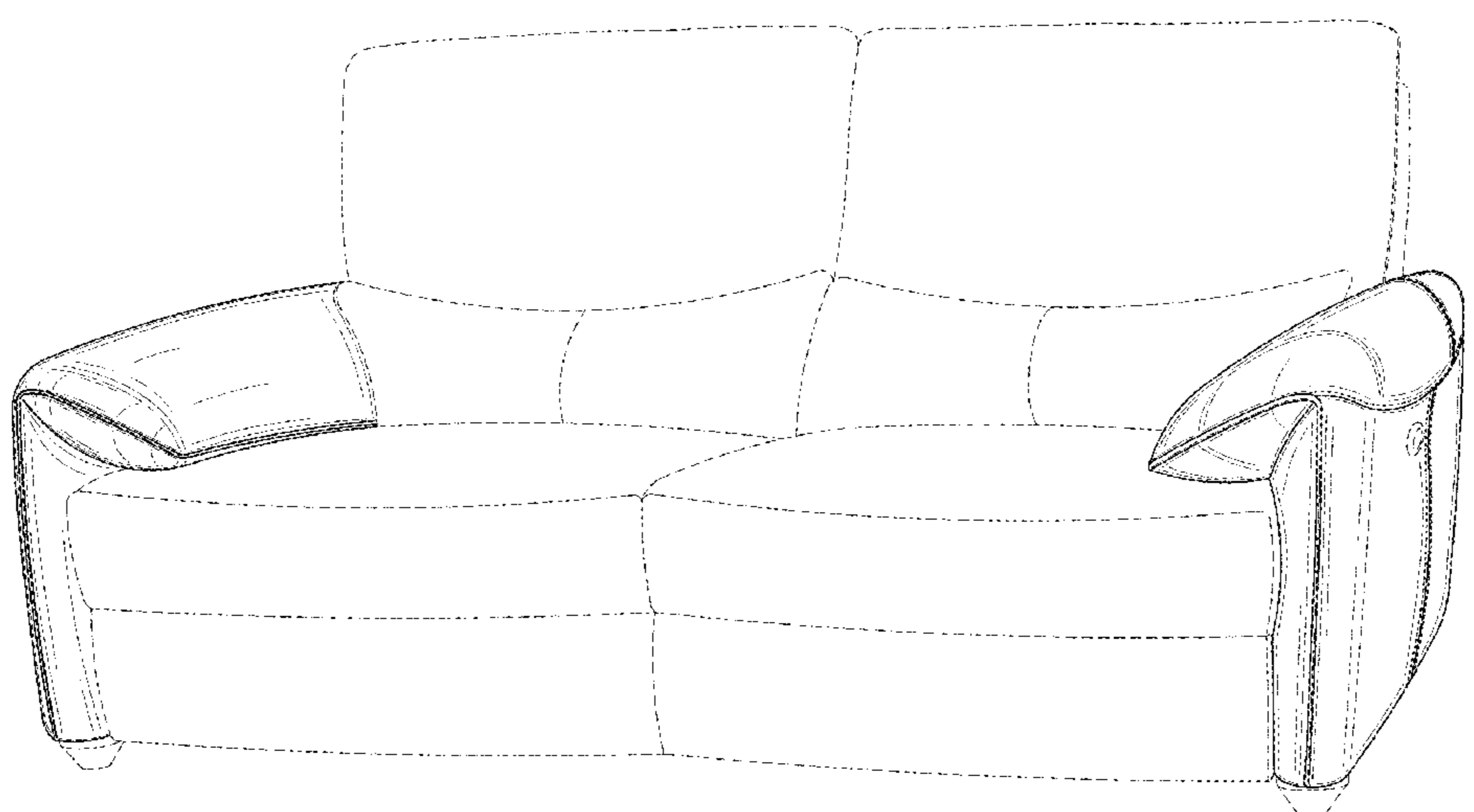

(56)

**References Cited**

U.S. PATENT DOCUMENTS

D544,238	S	*	6/2007	Ricci	.....	D6/334
D544,239	S	*	6/2007	Ricci	.....	D6/334
D544,240	S	*	6/2007	Ricci	.....	D6/334
D547,085	S	*	7/2007	Natuzzi	.....	D6/381
D547,091	S	*	7/2007	Natuzzi	.....	D6/381
D547,968	S	*	8/2007	Ricci	.....	D6/381
D549,982	S	*	9/2007	Natuzzi	.....	D6/381
D551,461	S	*	9/2007	Ricci	.....	D6/381
D552,868	S	*	10/2007	Natuzzi	.....	D6/381
D552,872	S	*	10/2007	Natuzzi	.....	D6/381
D566,981	S	*	4/2008	Natuzzi	.....	D6/381
D567,528	S	*	4/2008	Natuzzi	.....	D6/381
D590,168	S	*	4/2009	Natuzzi	.....	D6/381
D590,172	S	*	4/2009	Natuzzi	.....	D6/381
D590,174	S	*	4/2009	Natuzzi	.....	D6/381
D590,177	S	*	4/2009	Natuzzi	.....	D6/381
D618,471	S	*	6/2010	Natuzzi	.....	D6/381
D721,515	S	*	1/2015	Adair	.....	D6/381
D741,082	S	*	10/2015	Dix	.....	D6/381

\* cited by examiner

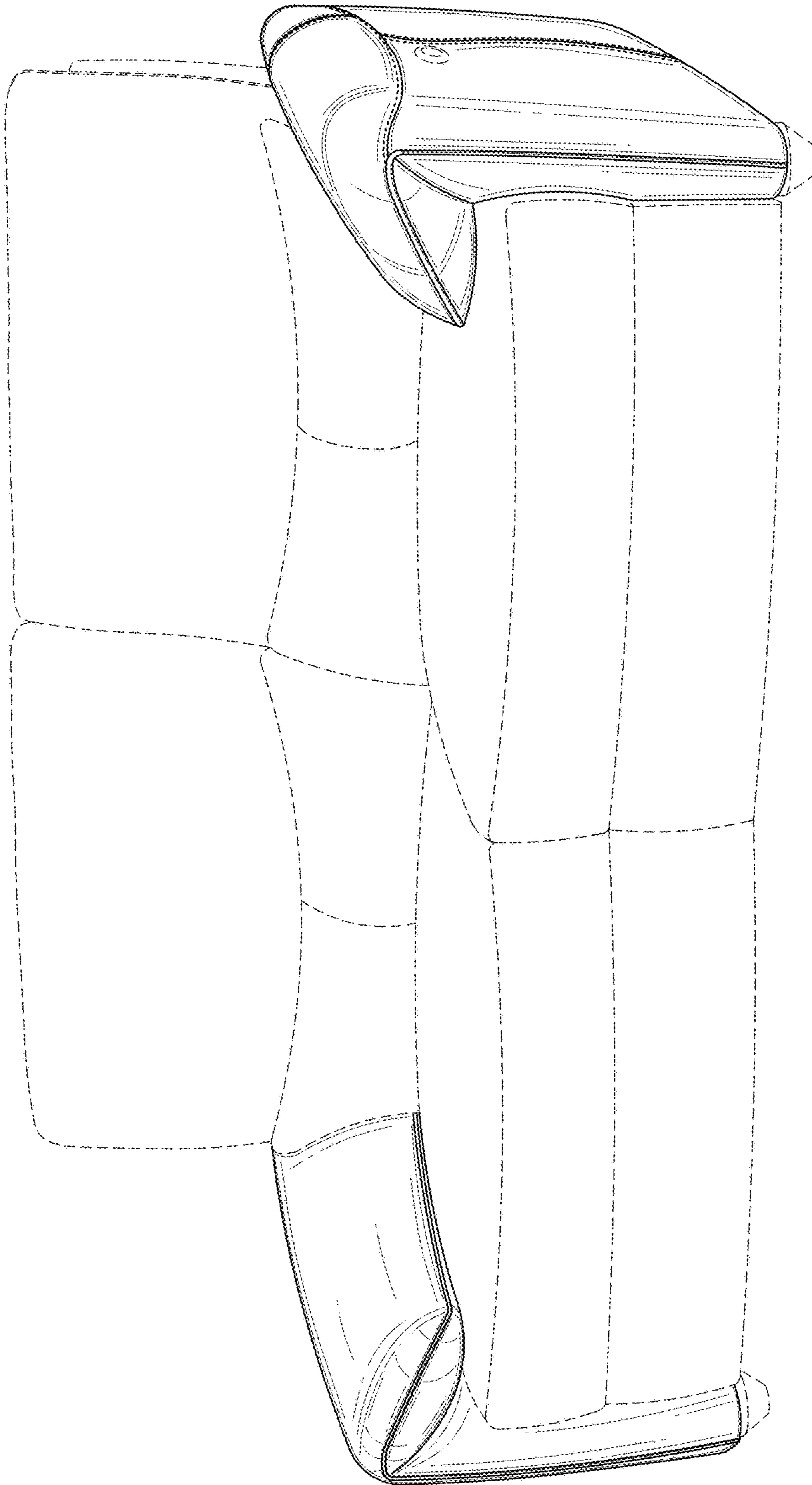

FIG. 1

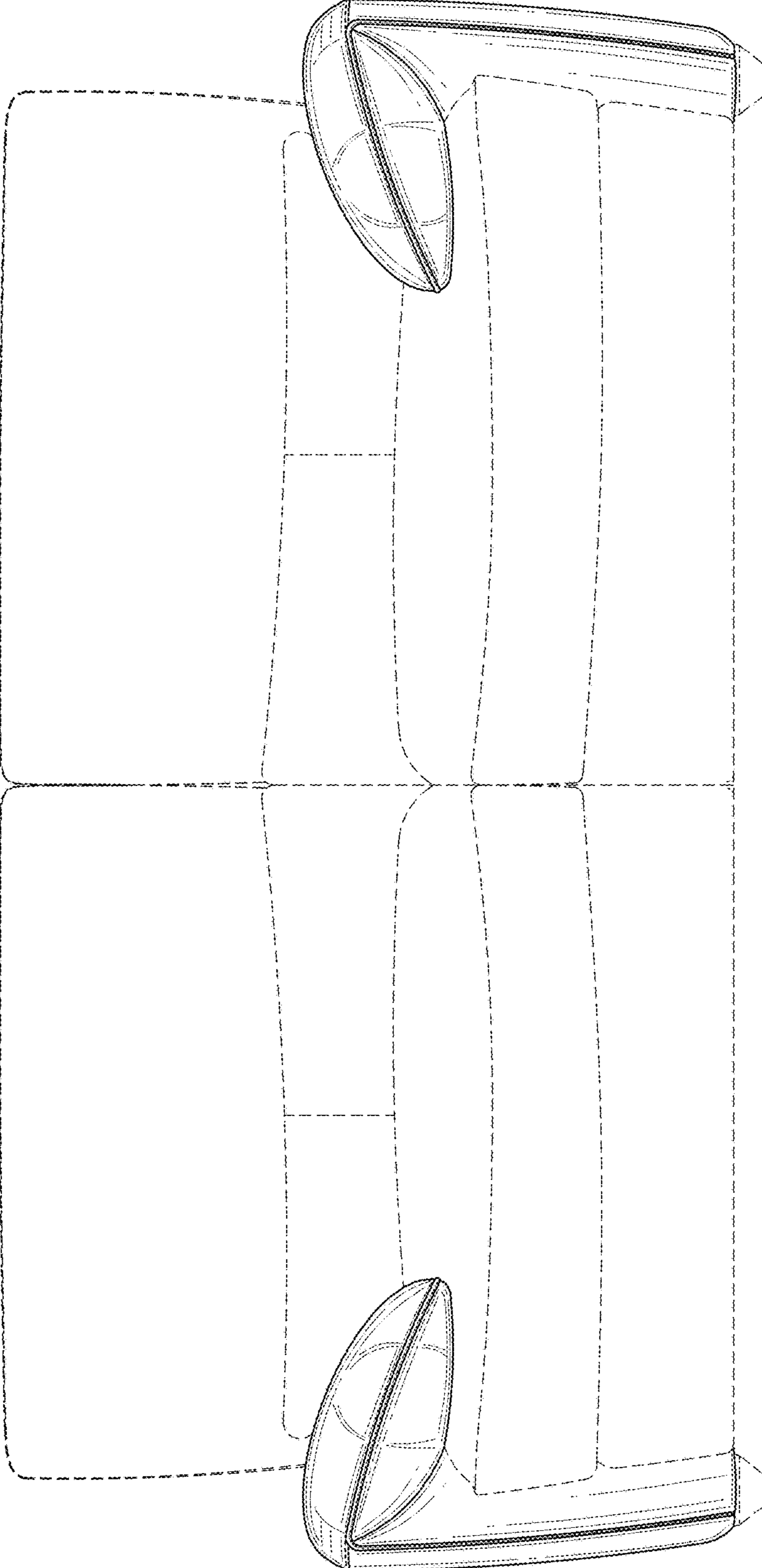

FIG. 2

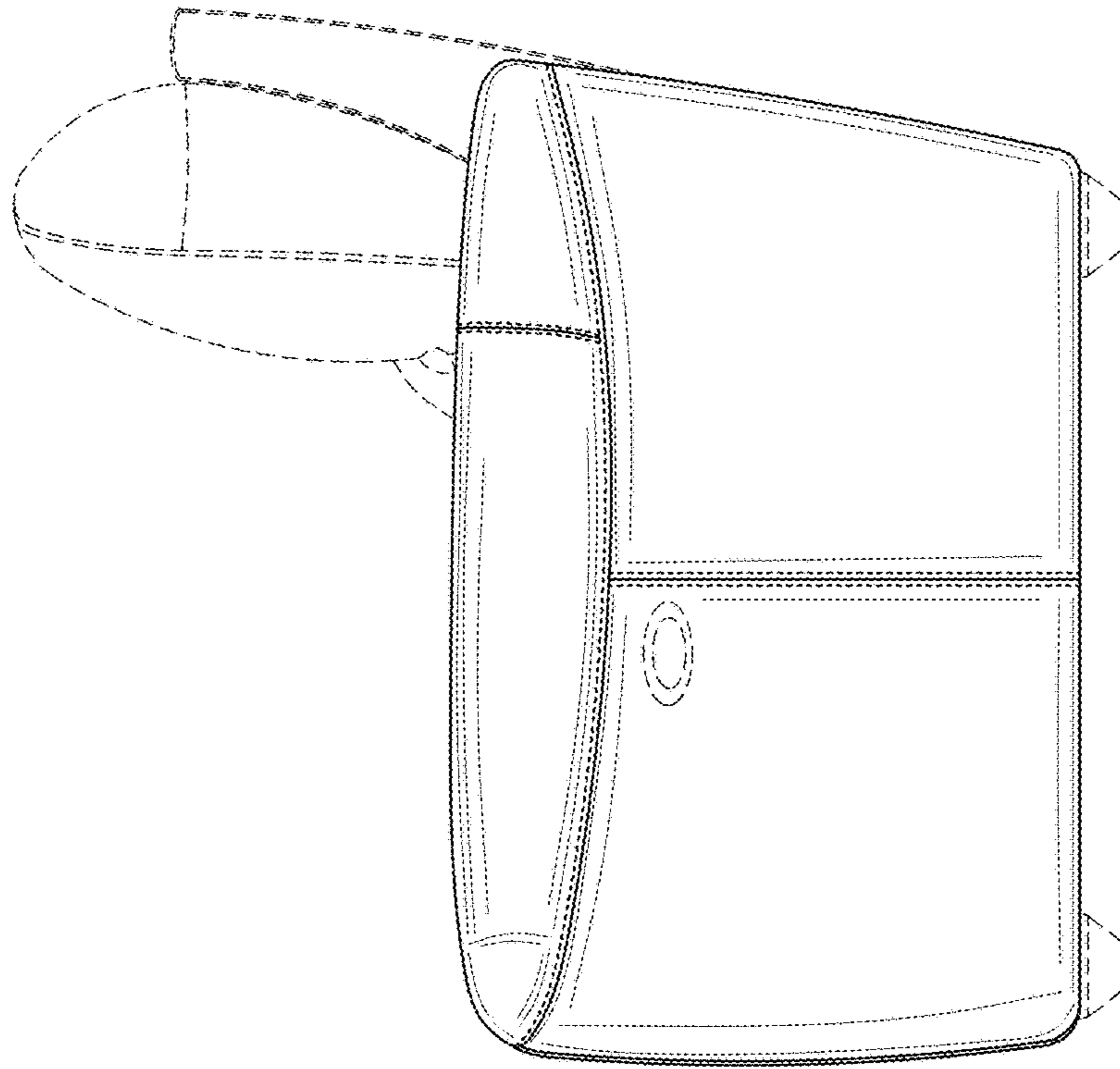

FIG. 4

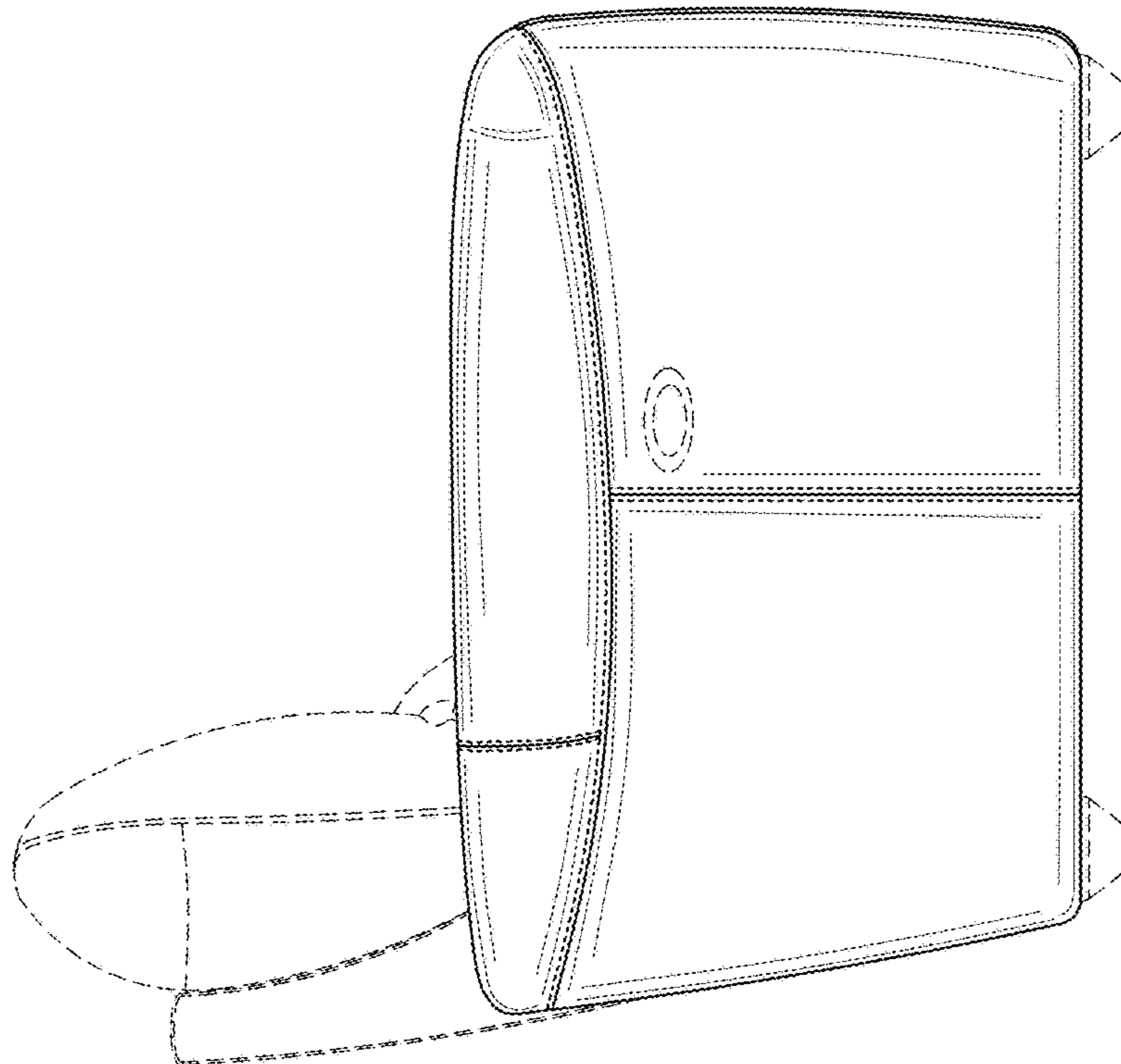

FIG. 3

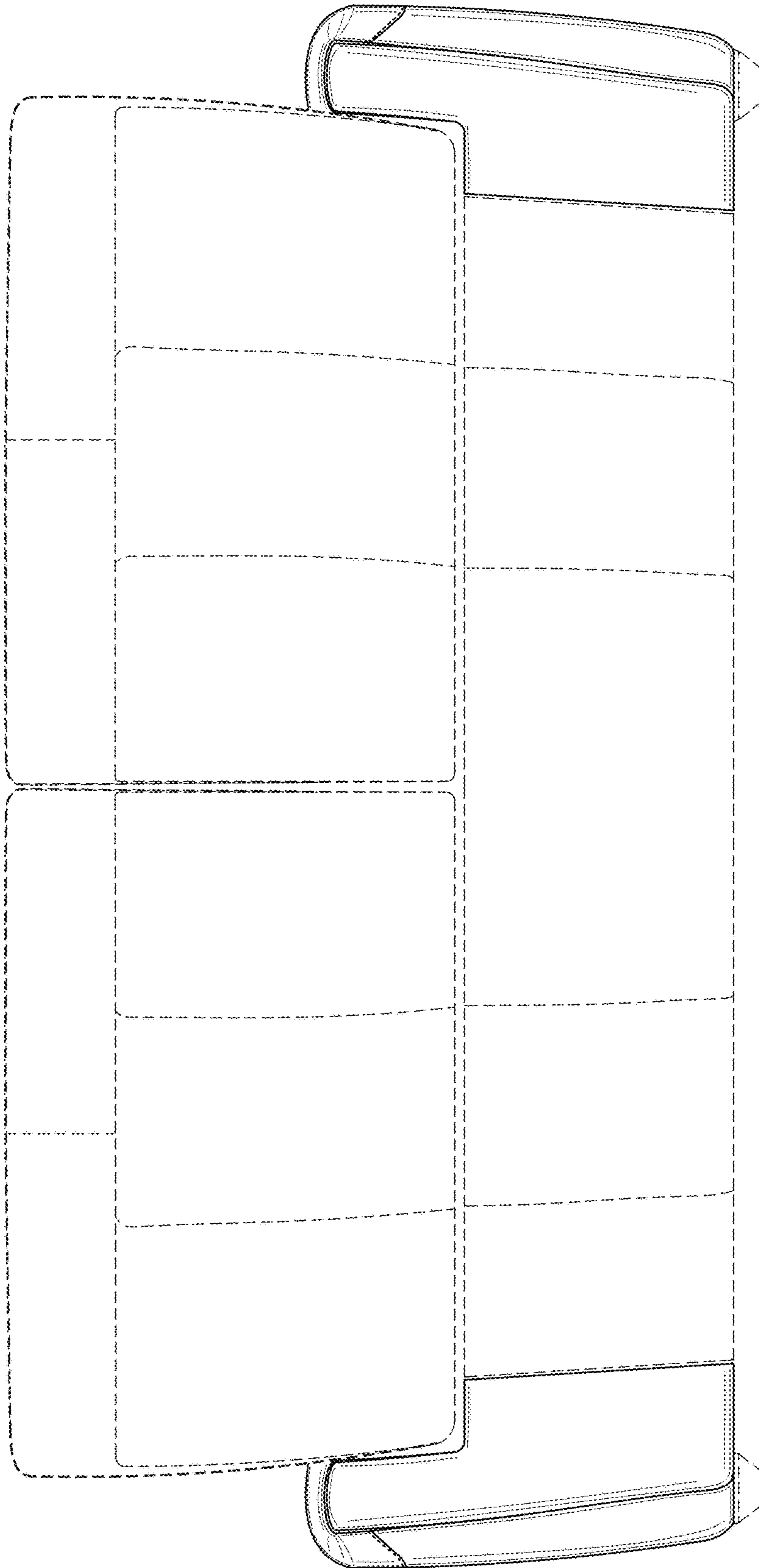

FIG. 5

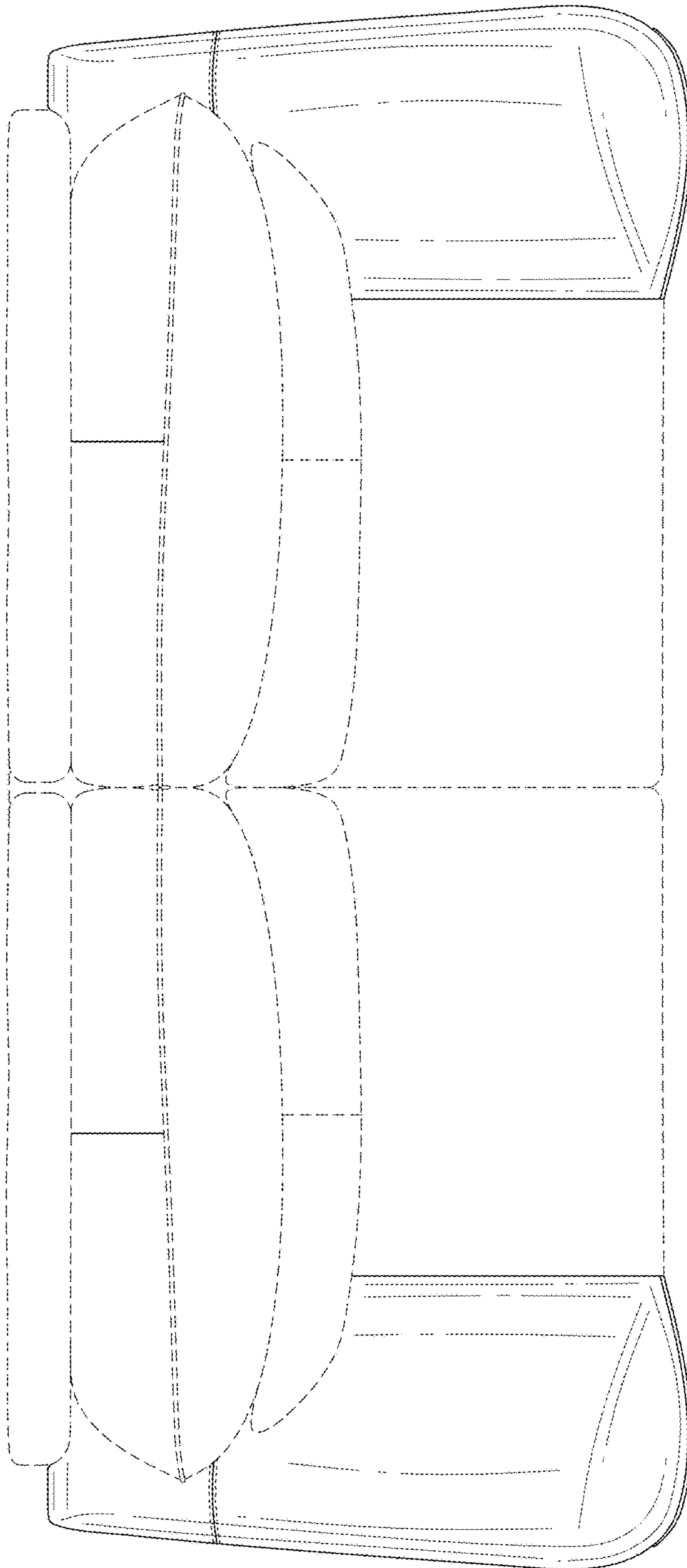

FIG. 6

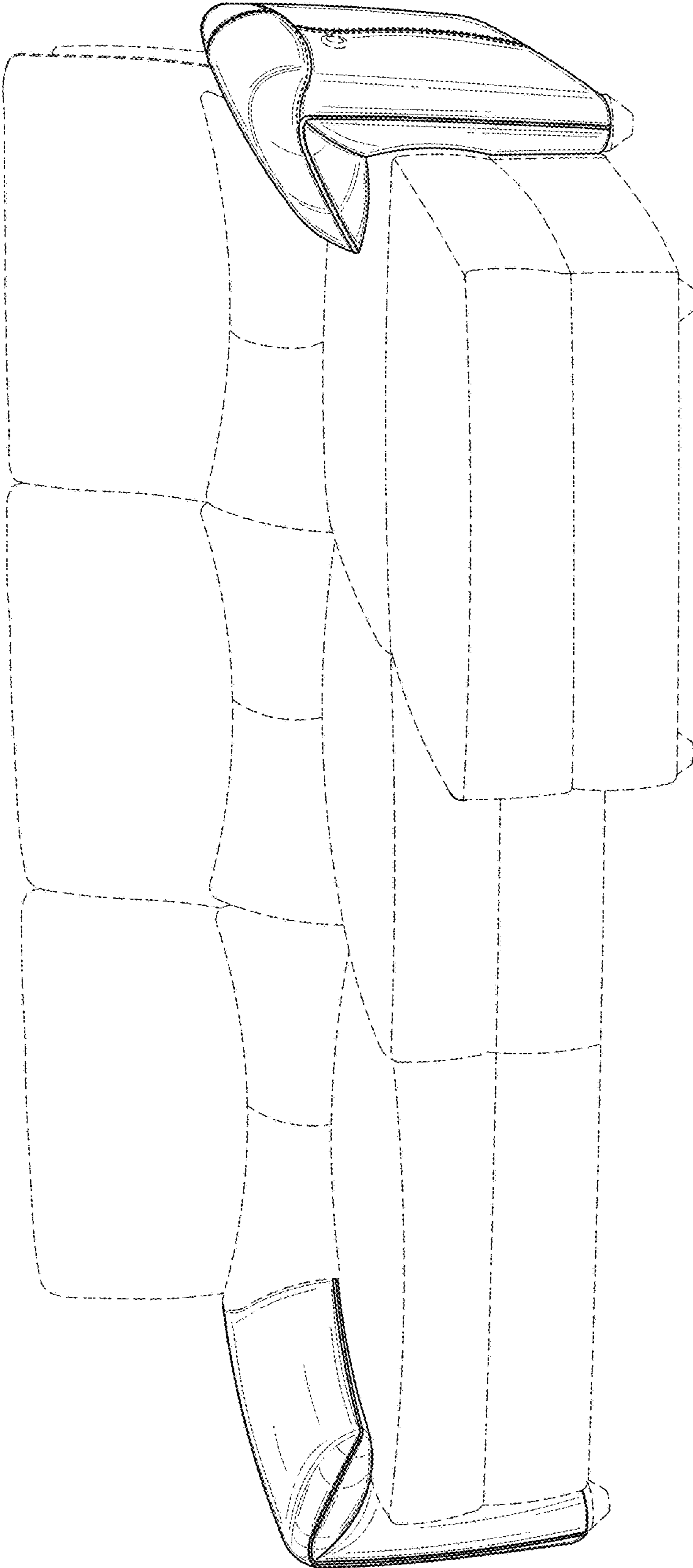

FIG. 7



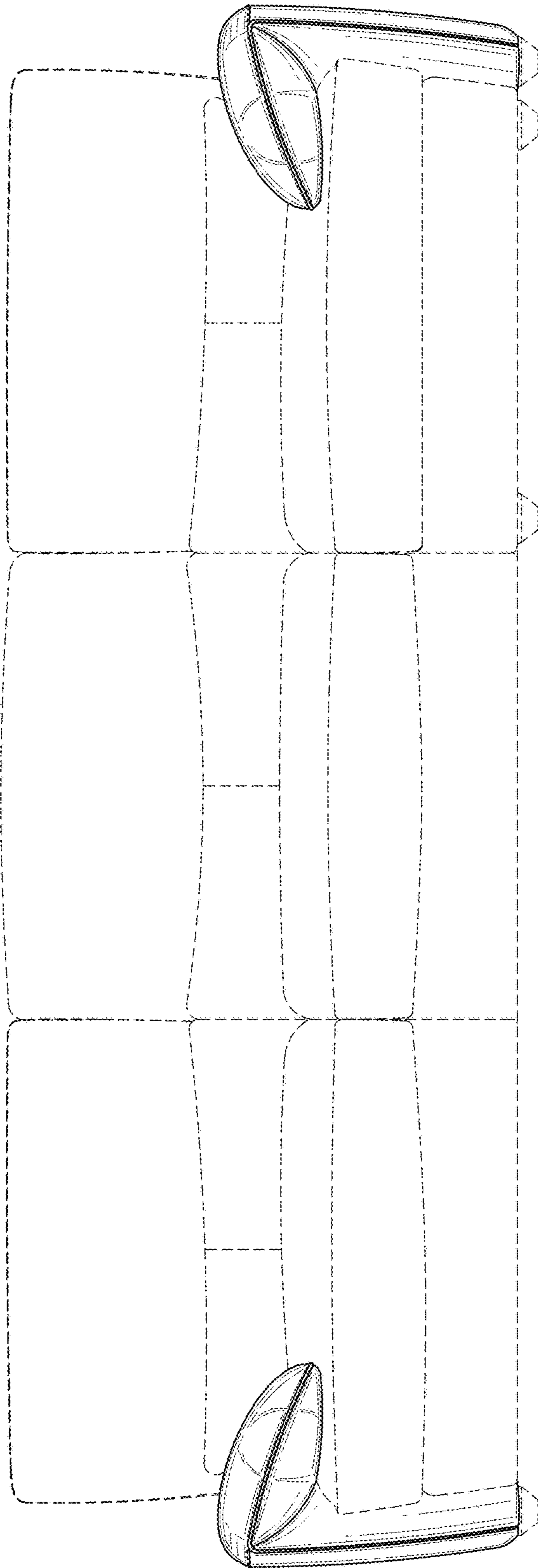

FIG. 8

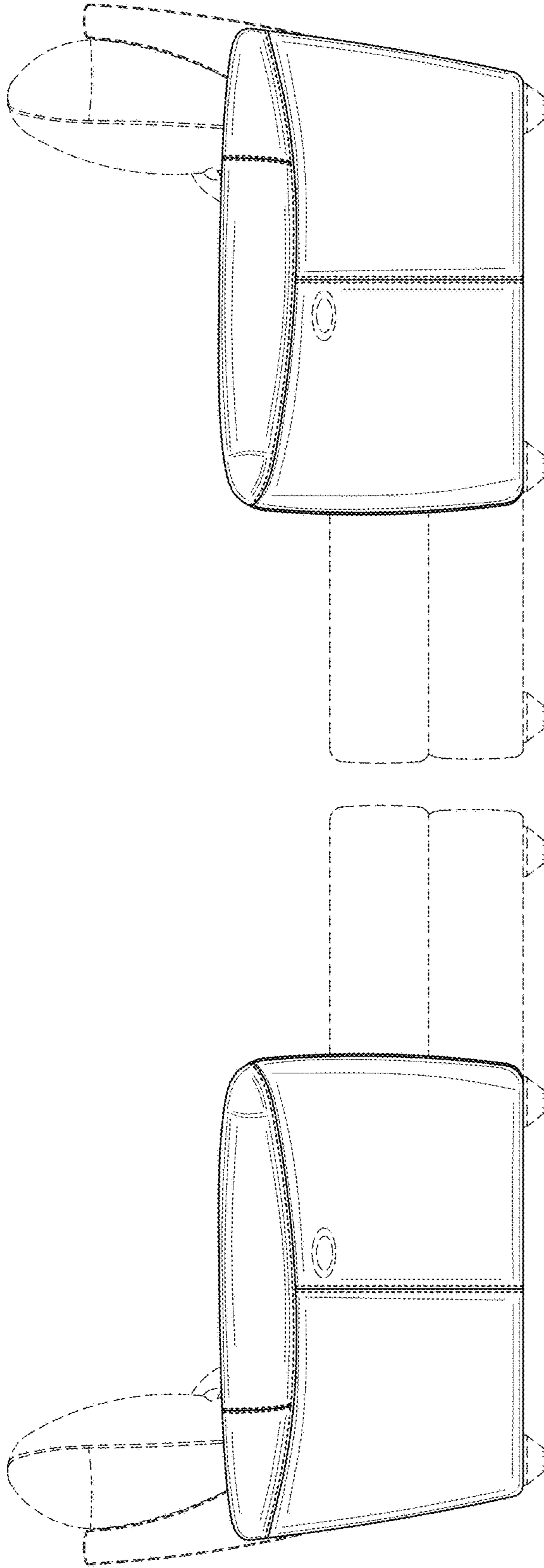

FIG. 10

FIG. 9

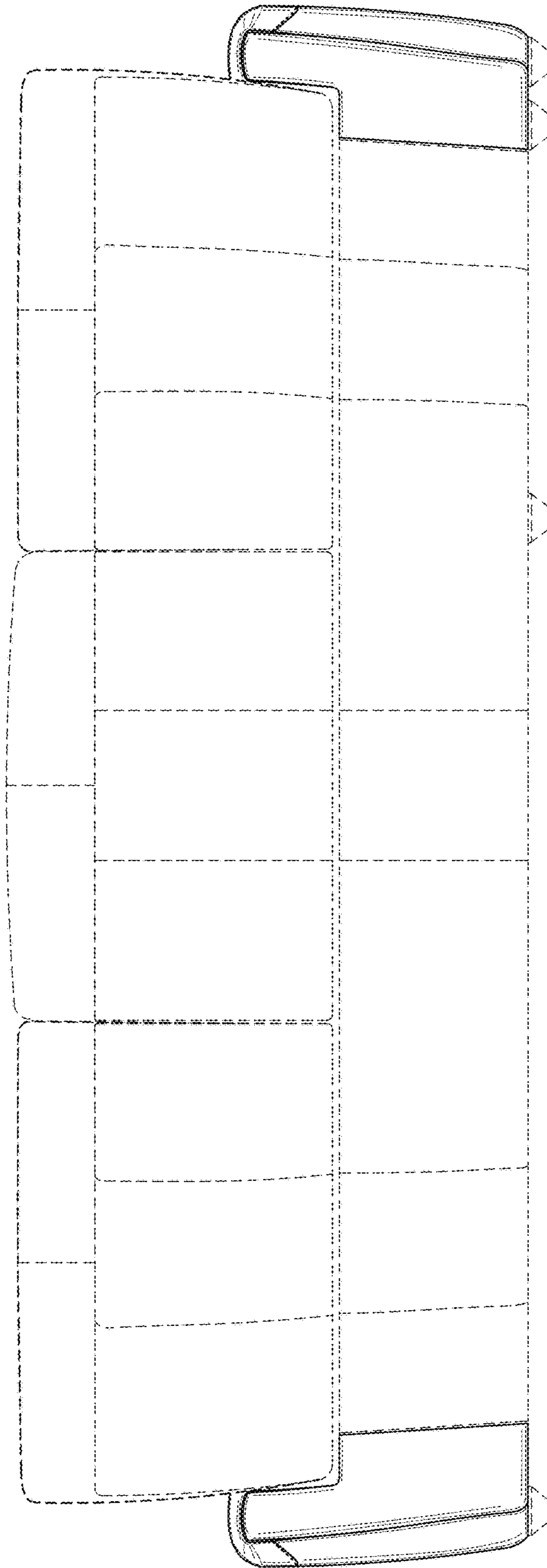

FIG. 11

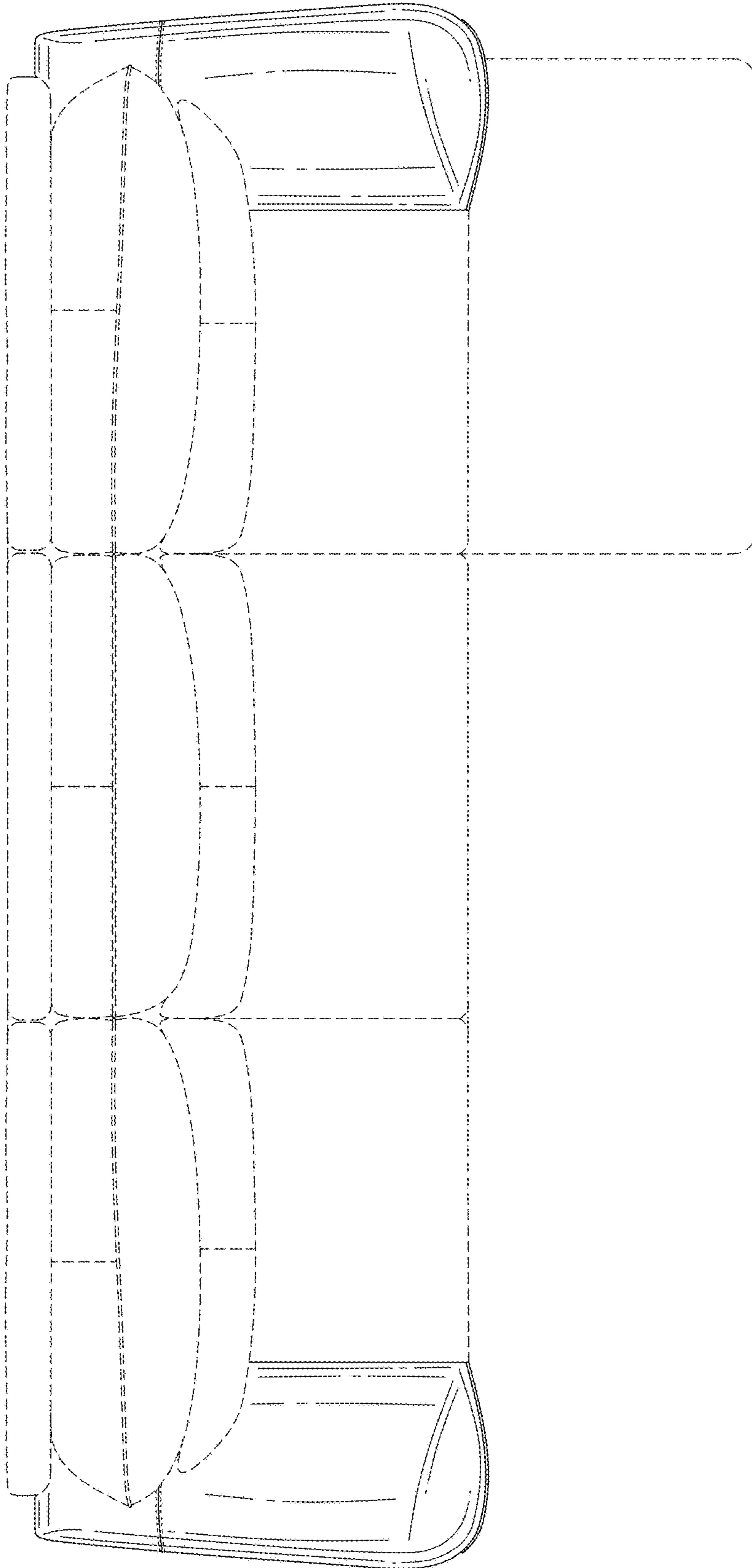

FIG. 12

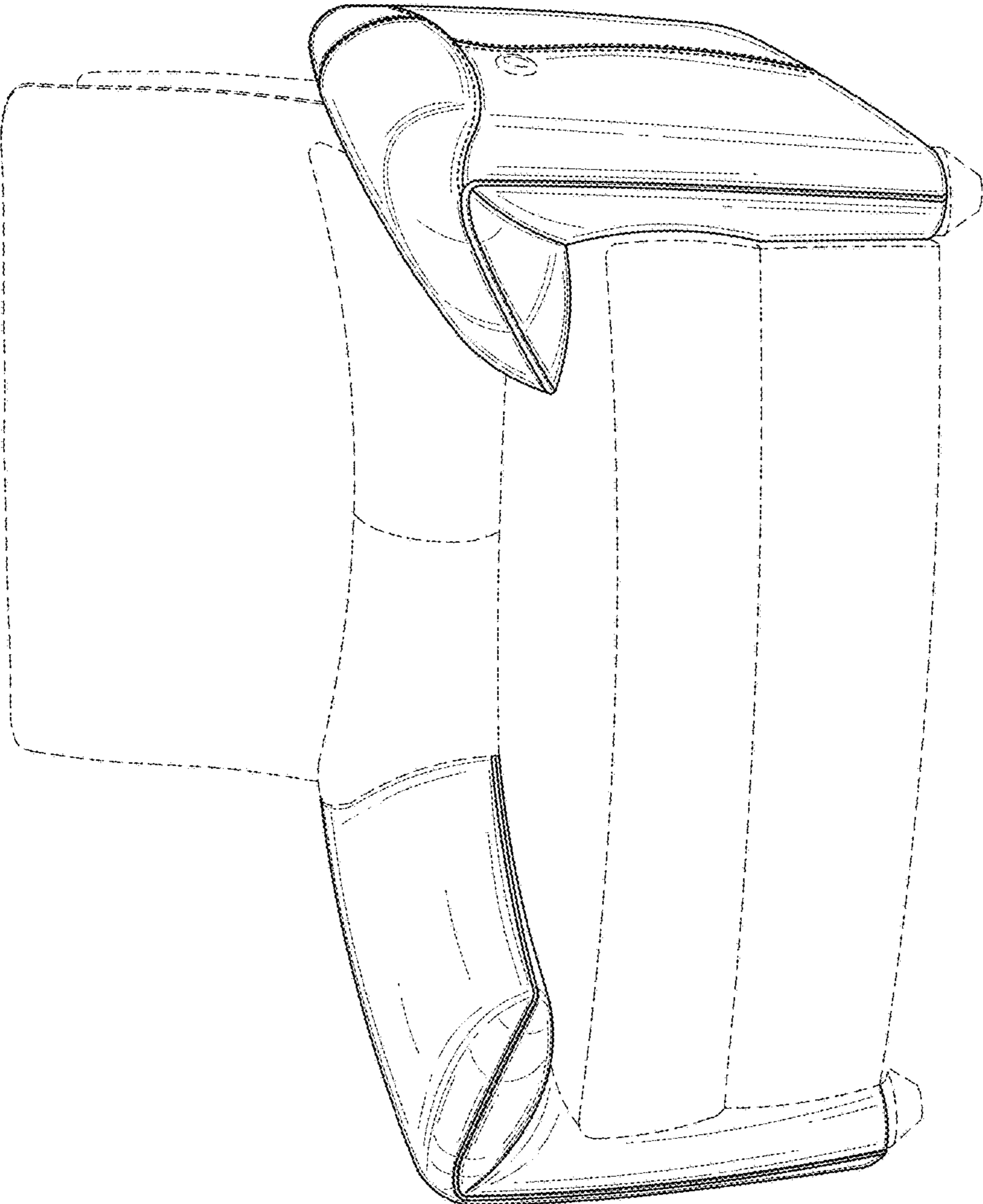

FIG. 13

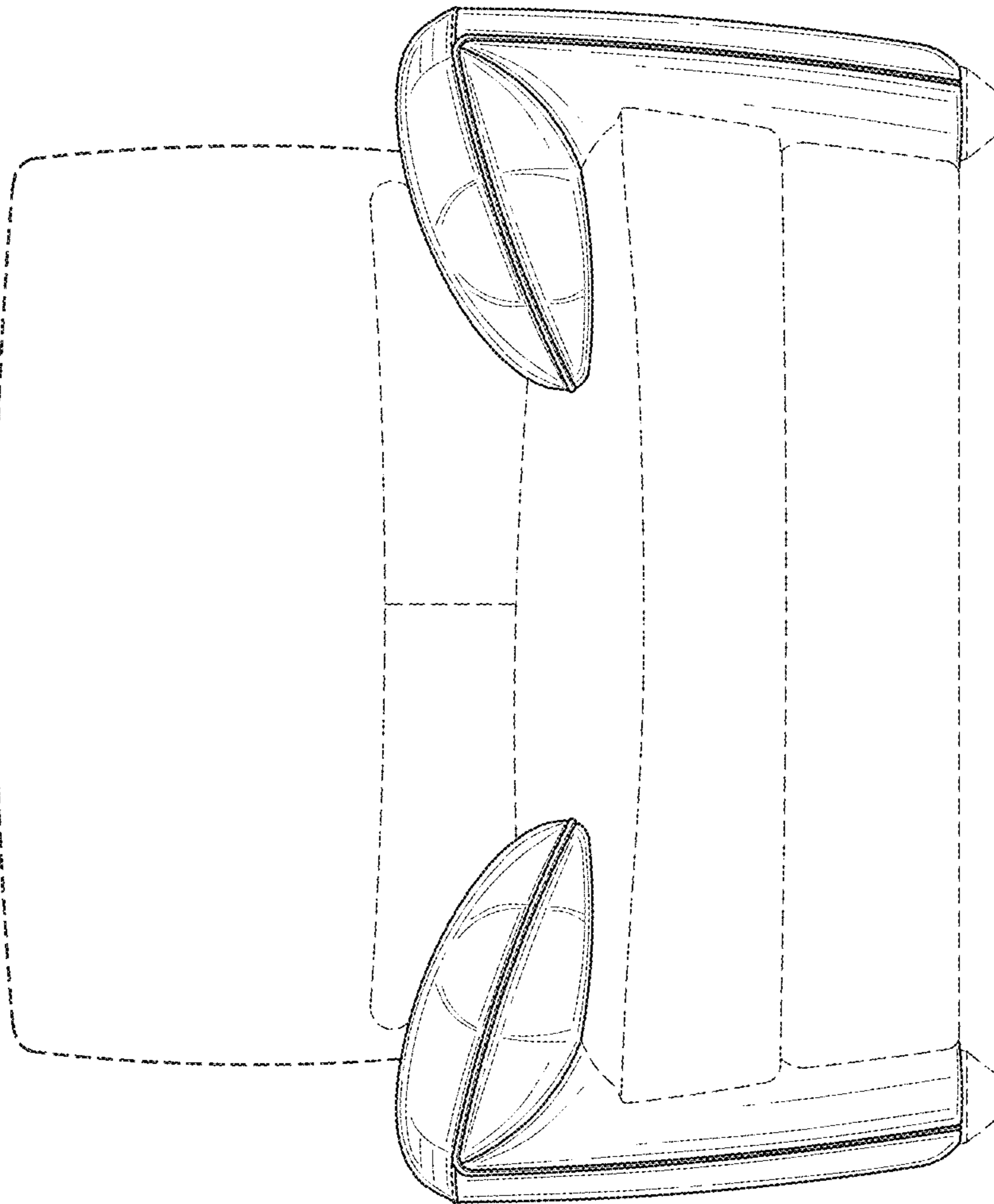

FIG. 14

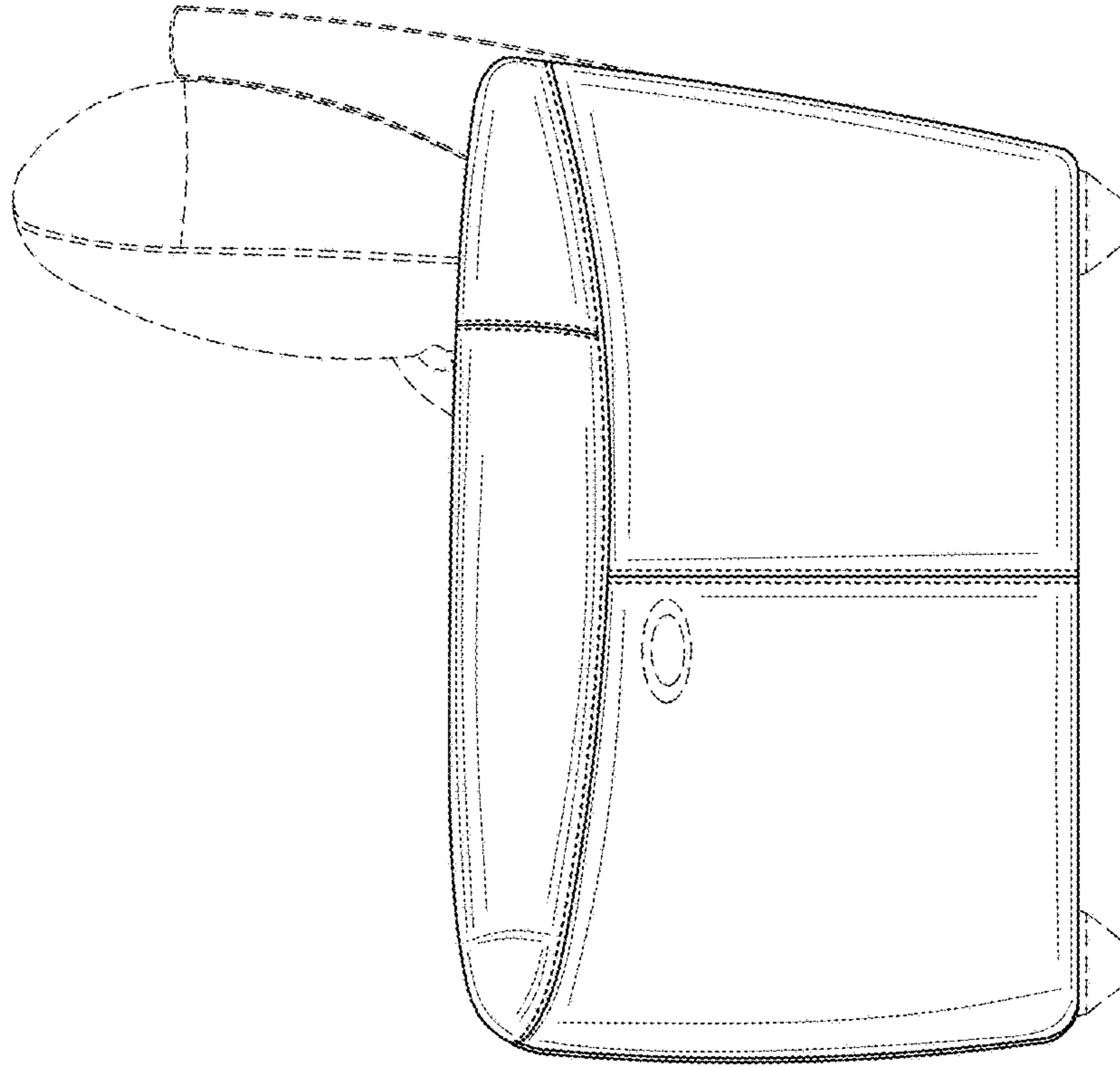

FIG. 15

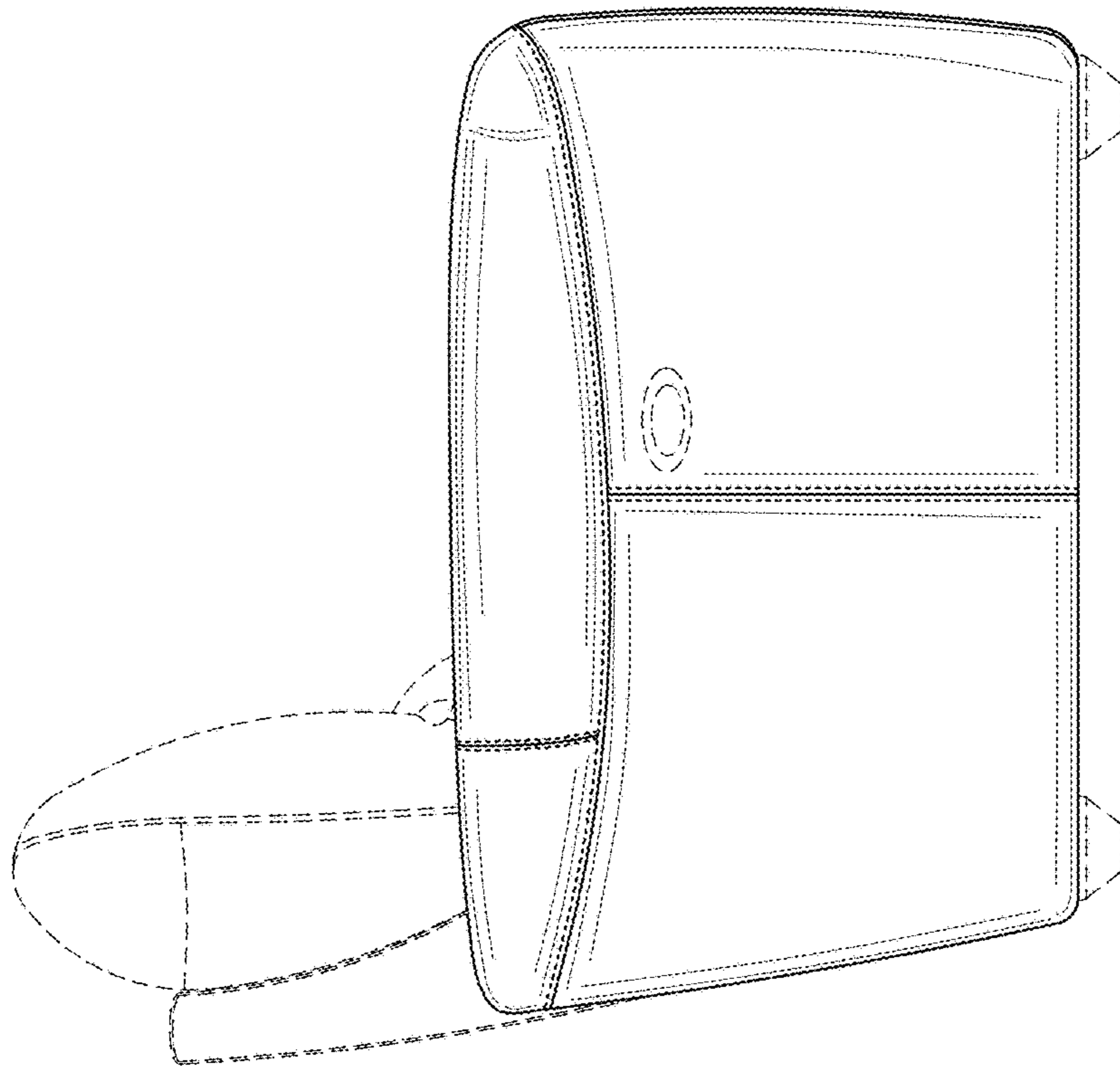

FIG. 16

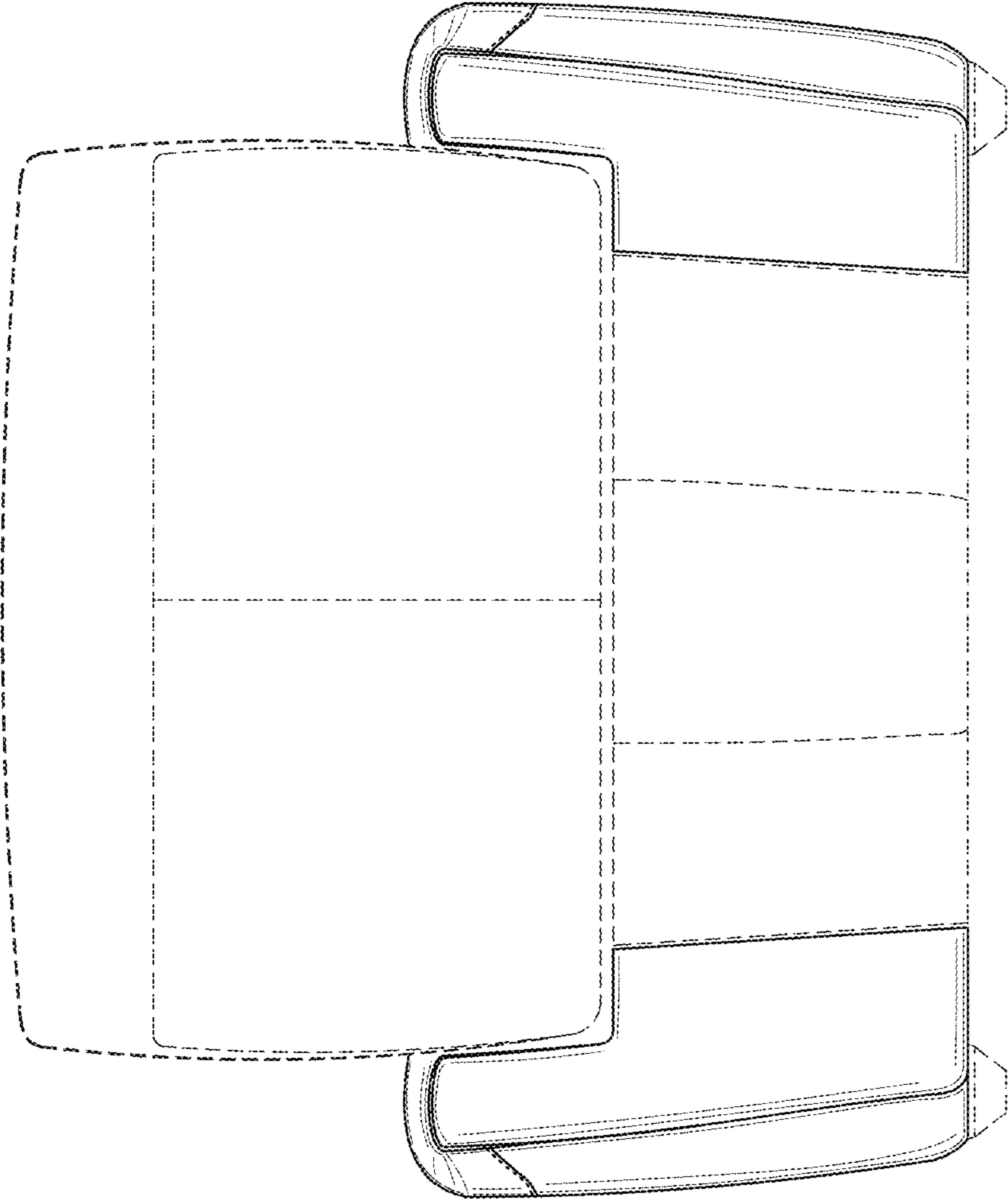

FIG. 17



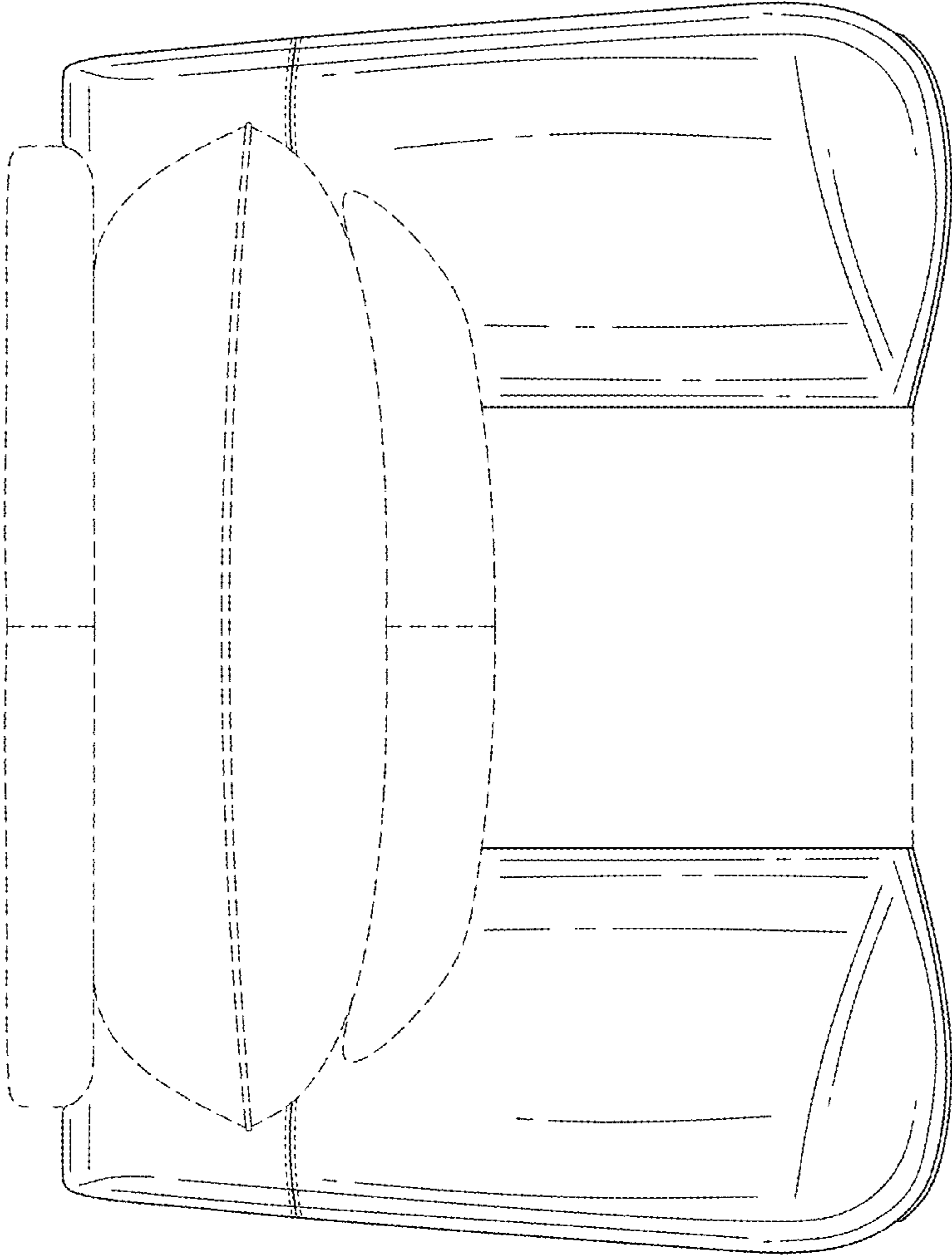

FIG. 18