



US00D782406S

(12) **United States Design Patent**
Takahashi

(10) **Patent No.:** **US D782,406 S**

(45) **Date of Patent:** **** Mar. 28, 2017**

(54) **AUTOMOBILE TIRE**

(71) Applicant: **TOYO TIRE & RUBBER CO., LTD.**,
Osaka-shi, Osaka (JP)

(72) Inventor: **Toshihiko Takahashi**, Osaka (JP)

(73) Assignee: **TOYO TIRE & RUBBER CO., LTD.**,
Osaka-shi (JP)

(**) Term: **15 Years**

(21) Appl. No.: **29/538,552**

(22) Filed: **Sep. 4, 2015**

(30) **Foreign Application Priority Data**

Mar. 26, 2015 (JP) 2015-006534

(51) **LOC (10) Cl.** **12-15**

(52) **U.S. Cl.**
USPC **D12/605**

(58) **Field of Classification Search**
USPC D12/605, 604
CPC B60C 13/00; B60C 1/00
See application file for complete search history.

(56) **References Cited**

U.S. PATENT DOCUMENTS

D570,768 S *	6/2008	Takahashi	D12/605
D596,117 S *	7/2009	Yonetsu	D12/605
D596,119 S *	7/2009	Fujita	D12/605
D597,480 S *	8/2009	Umstot	D12/605
D618,165 S *	6/2010	Sato	D12/605
D647,473 S *	10/2011	Kujime	D12/605
D647,474 S *	10/2011	Takahashi	D12/605
D674,745 S *	1/2013	Miyazaki	D12/605
D683,695 S *	6/2013	Takeshima	D12/605

D684,109 S *	6/2013	Iwabuchi	D12/605
D709,025 S *	7/2014	Takahashi	D12/605
D750,555 S *	3/2016	Iwabuchi	D12/605

FOREIGN PATENT DOCUMENTS

JP 1444646 S 5/2012

* cited by examiner

Primary Examiner — George D Kirschbaum

Assistant Examiner — Clese Moore, Jr.

(74) *Attorney, Agent, or Firm* — Westerman, Hattori,
Daniels & Adrian, LLP

(57) **CLAIM**

The ornamental design for an automobile tire, as shown and described.

DESCRIPTION

FIG. 1 is a front, elevation view of an automobile tire showing my new design;
FIG. 2 is a rear, elevation view thereof;
FIG. 3 is a left-side, elevation view thereof, the right-side, elevation view being a mirror image thereof;
FIG. 4 is a top plan view thereof, the bottom plan view being a mirror image thereof;
FIG. 5 is a perspective view thereof;
FIG. 6 is an enlarged view along the line 6'-6' and the line 6-6 in FIG. 1 thereof; and,
FIG. 7 is an enlarged cross sectional view along the line 7'-7' in FIG. 6, in the area designated 7 in FIG. 4 and 7" in FIG. 6.

In the drawings, the broken lines defining the tread area, sidewall, and inner bead depict environmental subject matter that forms no part of the claimed design.

1 Claim, 7 Drawing Sheets

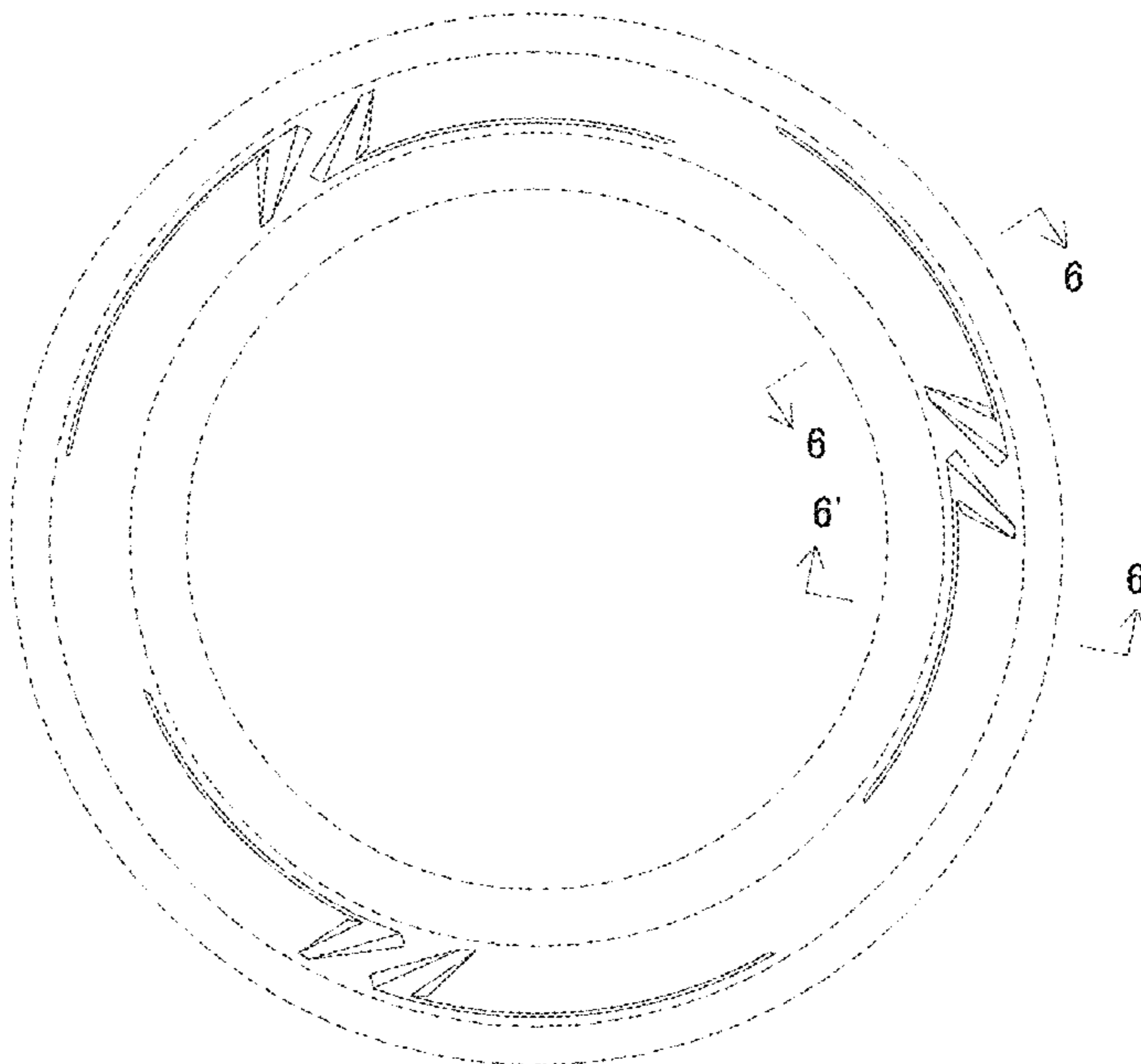

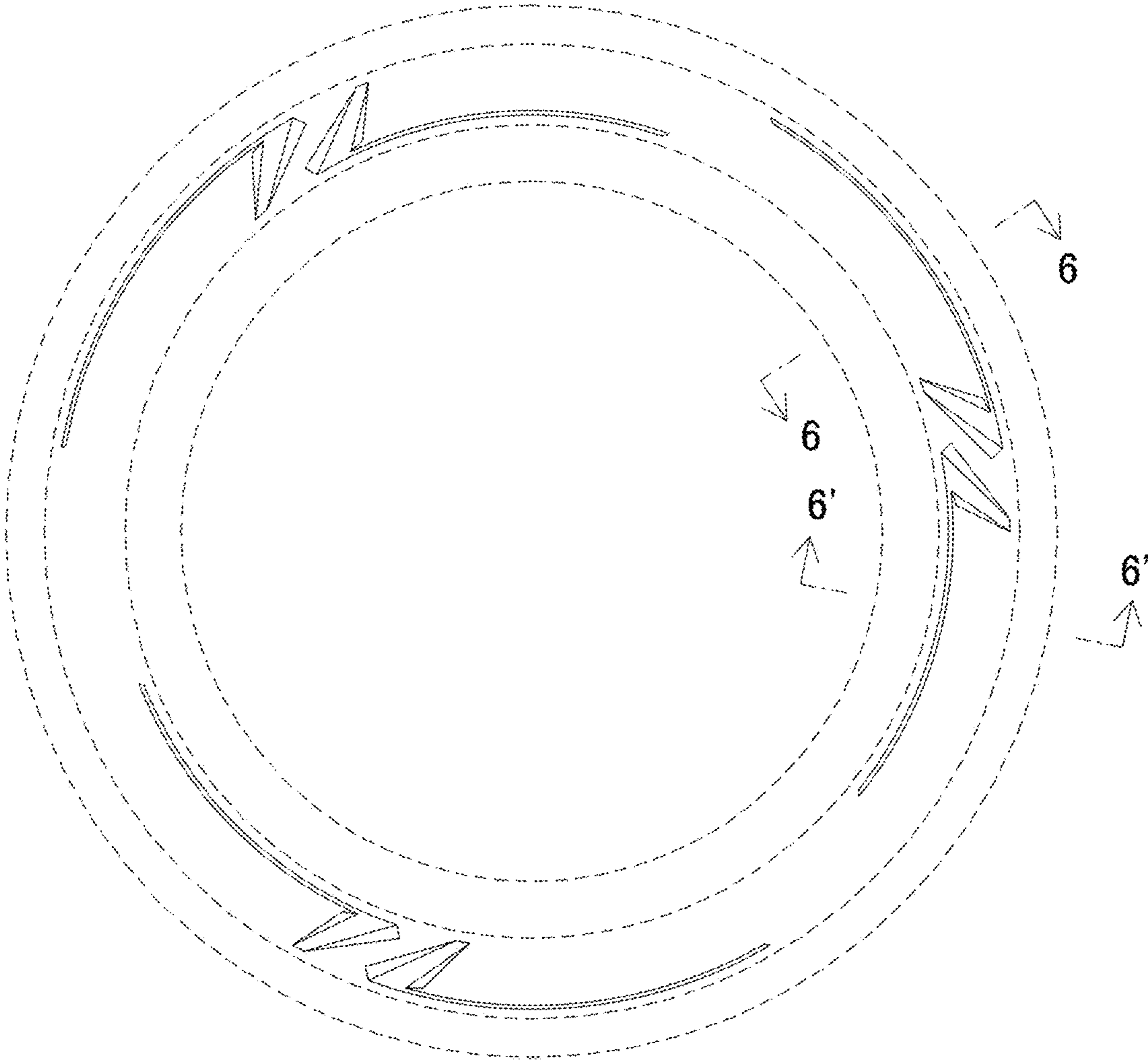

FIG.1

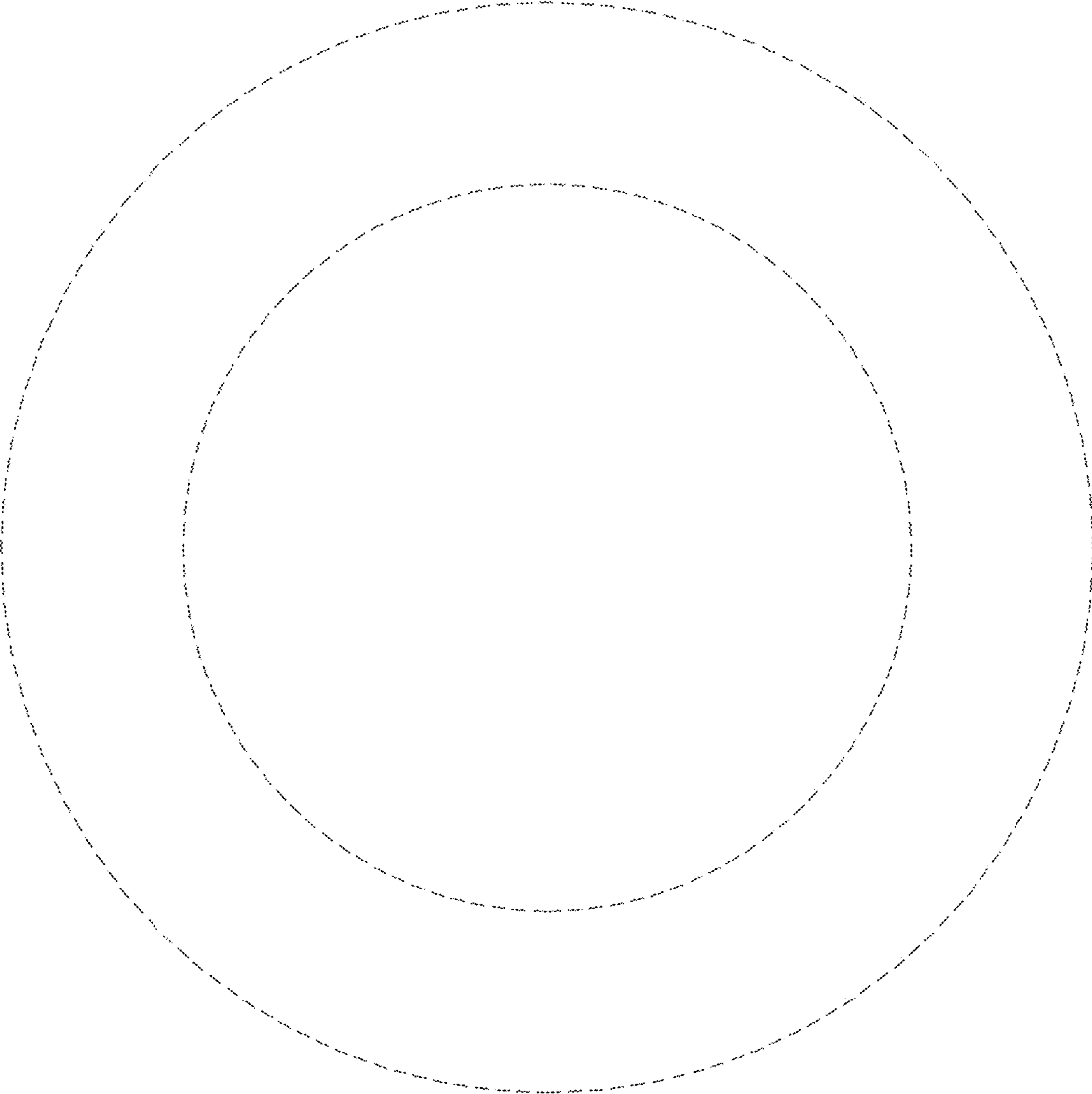

FIG.2

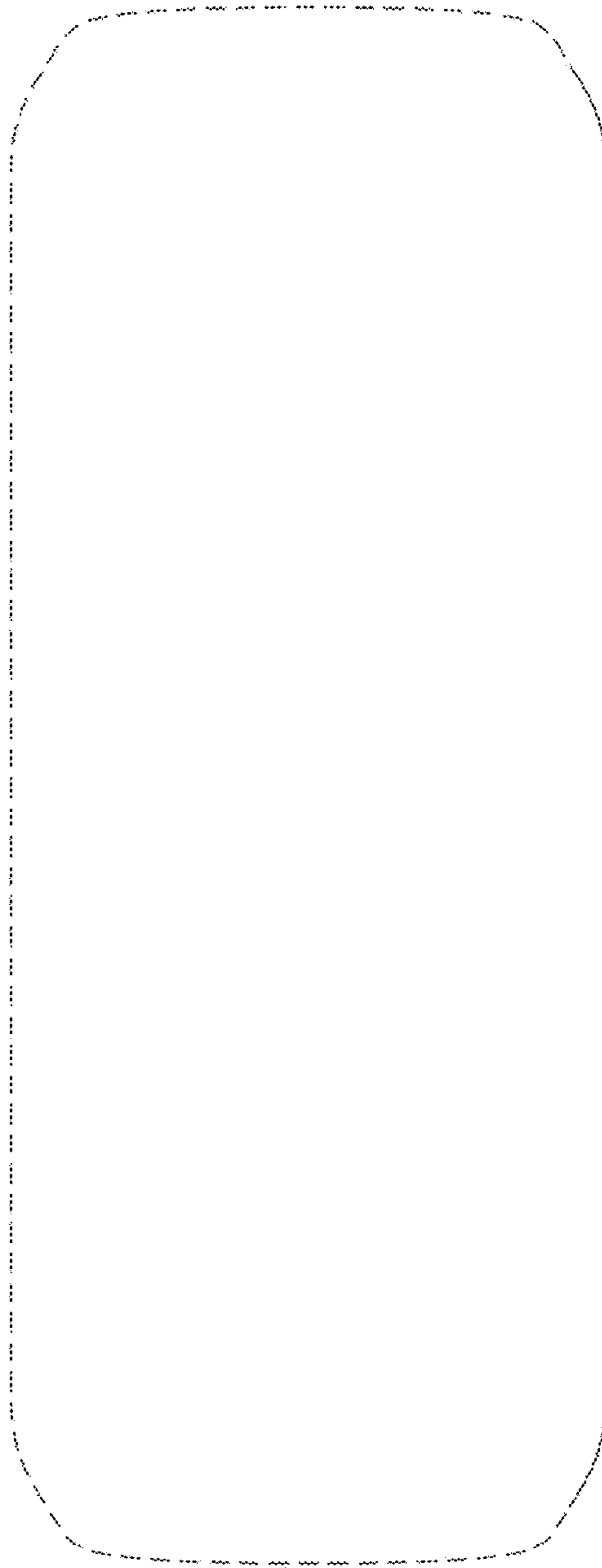

FIG.3

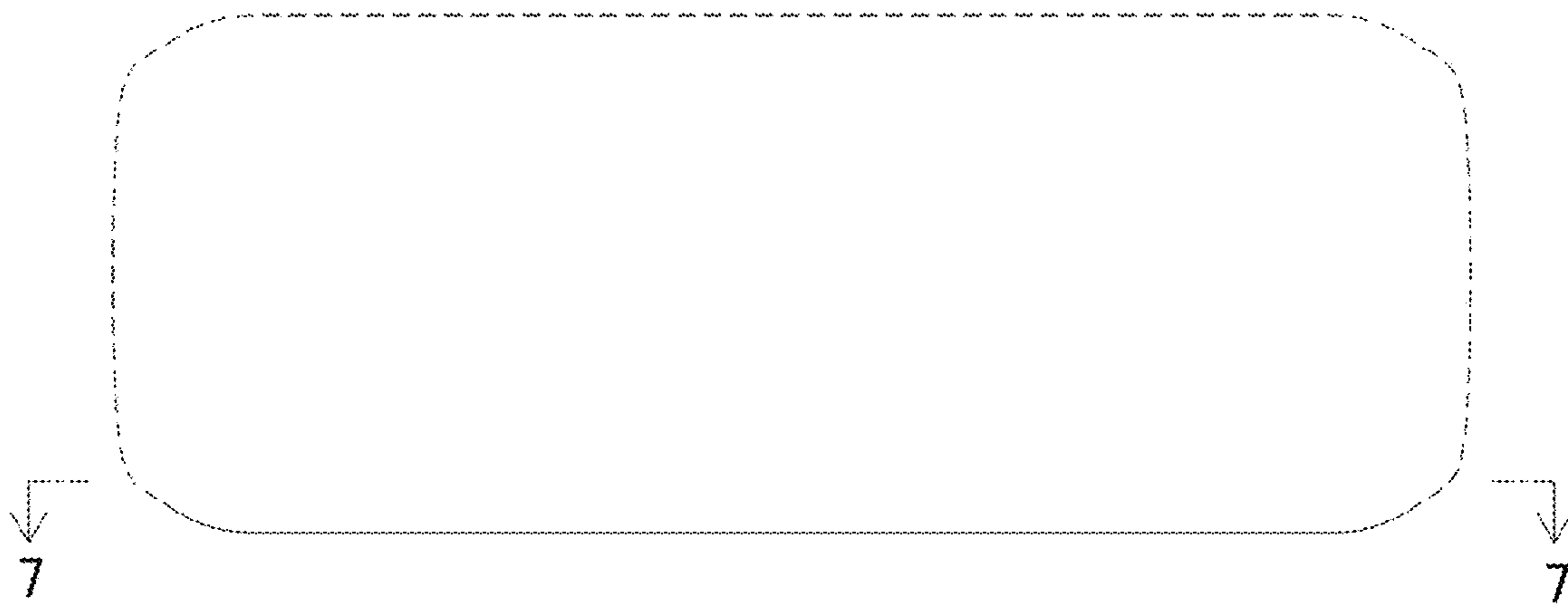

FIG.4

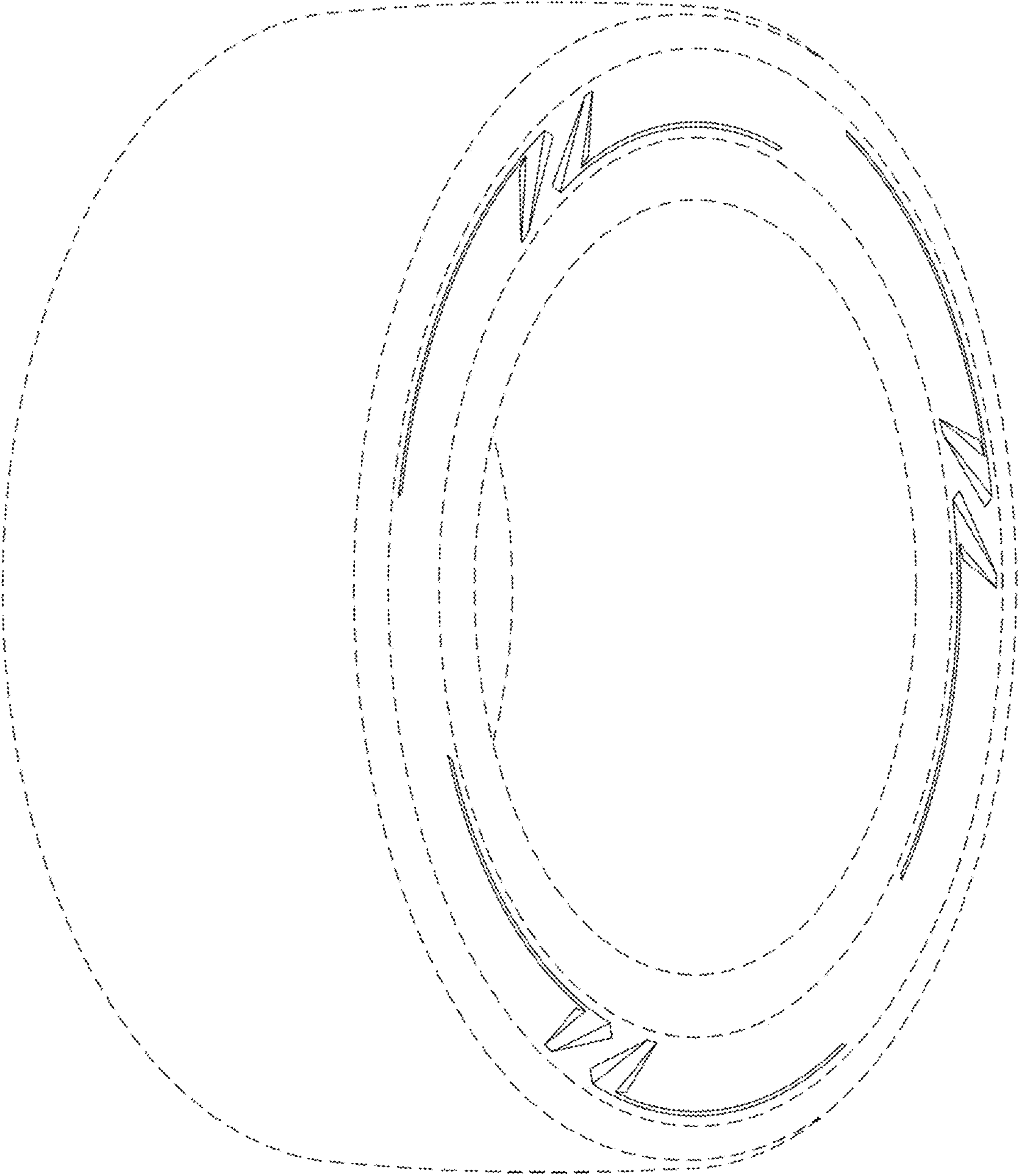

FIG.5

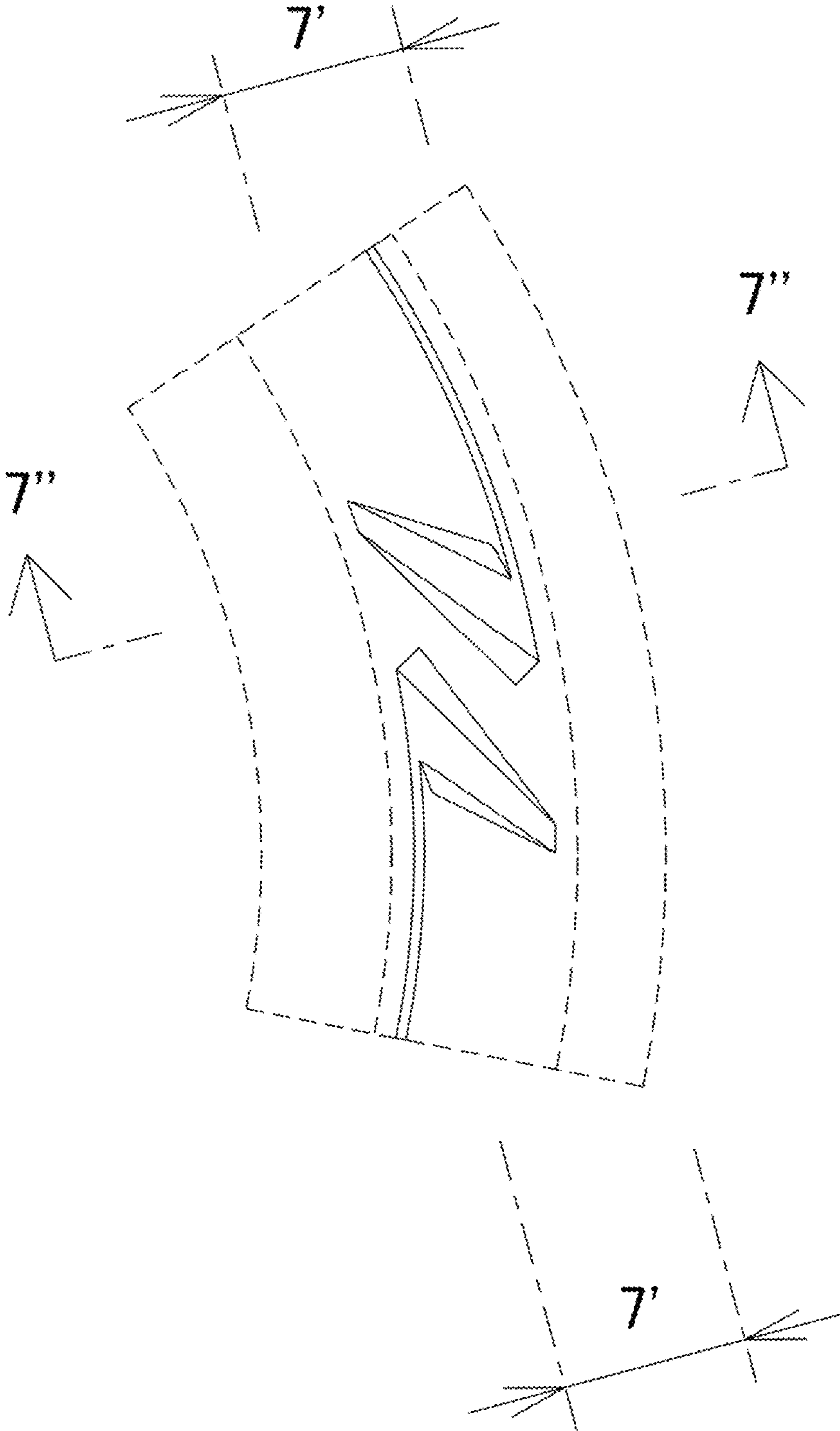

FIG.6



FIG.7