



US00D782298S

(12) **United States Design Patent**
de Baschmakoff

(10) **Patent No.:** **US D782,298 S**

(45) **Date of Patent:** **** Mar. 28, 2017**

(54) **PACKAGING FOR PERFUME BOTTLE**

(71) Applicant: **J. Choo Limited**, London (GB)

(72) Inventor: **Thierry de Baschmakoff**, Paris (FR)

(73) Assignee: **J. Choo Limited**, London (GB)

(**) Term: **15 Years**

(21) Appl. No.: **29/543,930**

(22) Filed: **Oct. 29, 2015**

(30) **Foreign Application Priority Data**

Jul. 8, 2015 (EM) 002733600-0003
Jul. 8, 2015 (EM) 002733600-0004

(51) **LOC (10) Cl.** **09-03**

(52) **U.S. Cl.**
USPC **D9/432**

(58) **Field of Classification Search**
USPC D9/430, 414, 432, 524, 516, 433, 431,
D9/756, 426, 725, 425, 242, 761, 418,
D9/416, 420, 737; D7/543, 545, 602,
D7/552.2, 538, 553.1, 553.2, 555, 541;
229/112, 120.17; D6/518
CPC B65D 1/00; B65D 5/4291; B65D 5/38;
B65D 1/225; B65D 5/002; A47F 5/11
See application file for complete search history.

(56) **References Cited**

U.S. PATENT DOCUMENTS

D167,181 S * 7/1952 Vuillemenot D9/522
D515,929 S * 2/2006 Steih D9/522
D515,930 S * 2/2006 Steih D9/522

D621,188 S * 8/2010 Brock D6/515
D655,613 S 3/2012 De Baschmakoff et al.
D655,614 S * 3/2012 De Baschmakoff D9/432
D696,957 S 1/2014 Pinabel
D710,207 S 8/2014 Pinabel
D733,557 S * 7/2015 McAdam D9/432
D735,575 S * 8/2015 Rubio D9/432
D762,123 S * 7/2016 de Baschmakoff D9/418

* cited by examiner

Primary Examiner — Cynthia Underwood

(74) *Attorney, Agent, or Firm* — Fross Zelnick Lehrman & Zissu, P.C.; Lawrence E. Apolzon, Esq.

(57) **CLAIM**

The ornamental design for packaging for perfume bottle, as shown and described.

DESCRIPTION

FIG. 1 is a front perspective view of a packaging design showing my new design;
FIG. 2 is a front view thereof;
FIG. 3 is a back view thereof;
FIG. 4 is a left side view thereof;
FIG. 5 is a right side view thereof;
FIG. 6 is a top view thereof;
FIG. 7 is a bottom view thereof; and,
FIG. 8 is a cut-away view of the portion of the packaging indicated in FIG. 1, shown with surface shading, which is understood to extend across the entire surface of the packaging in FIGS. 1-7, except for the rectangular label element as shown in FIGS. 1-2.

The broken line showing of portions of the packaging in the relevant drawings shows unclaimed subject matter for the design in those drawings.

1 Claim, 8 Drawing Sheets

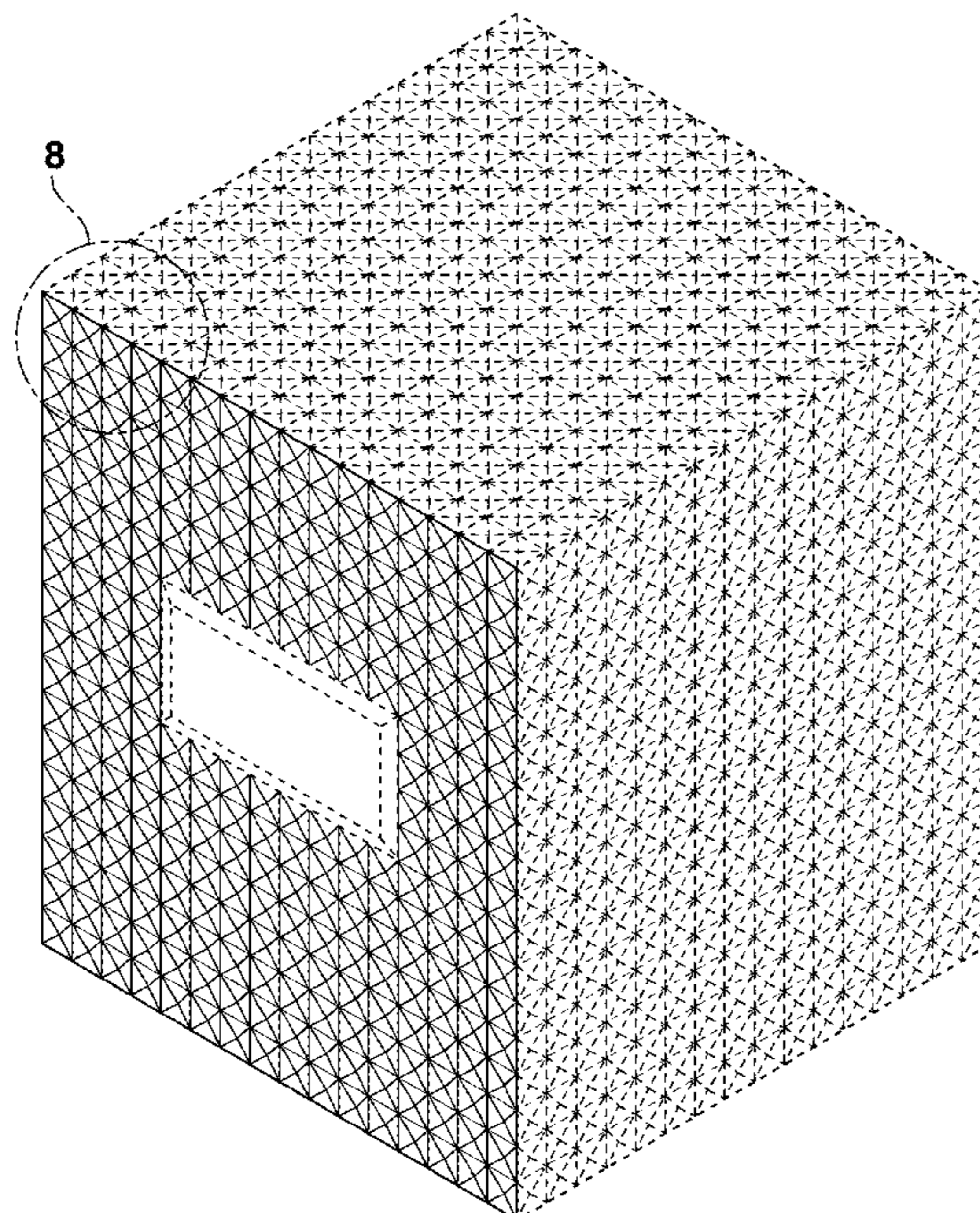

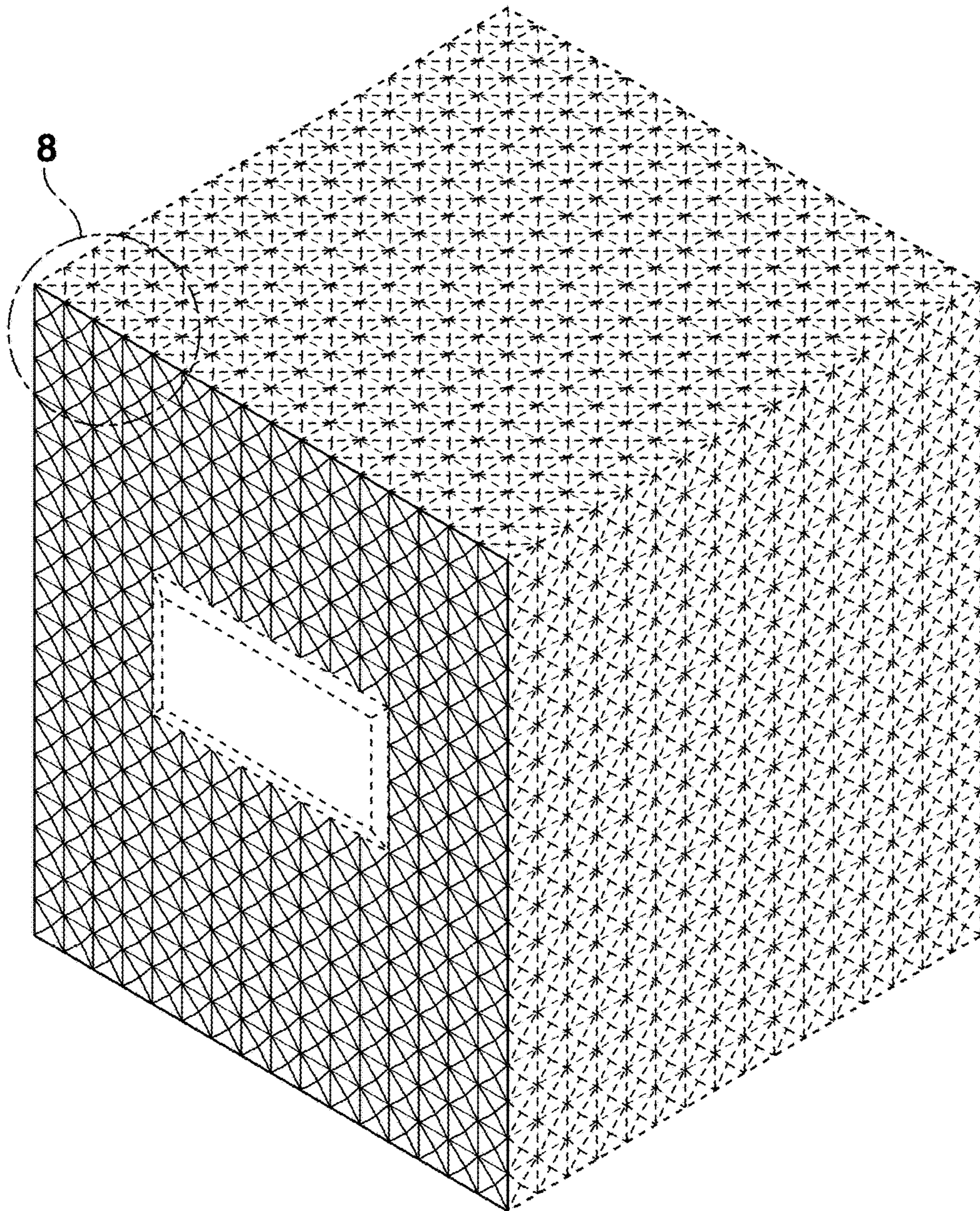

FIG. 1

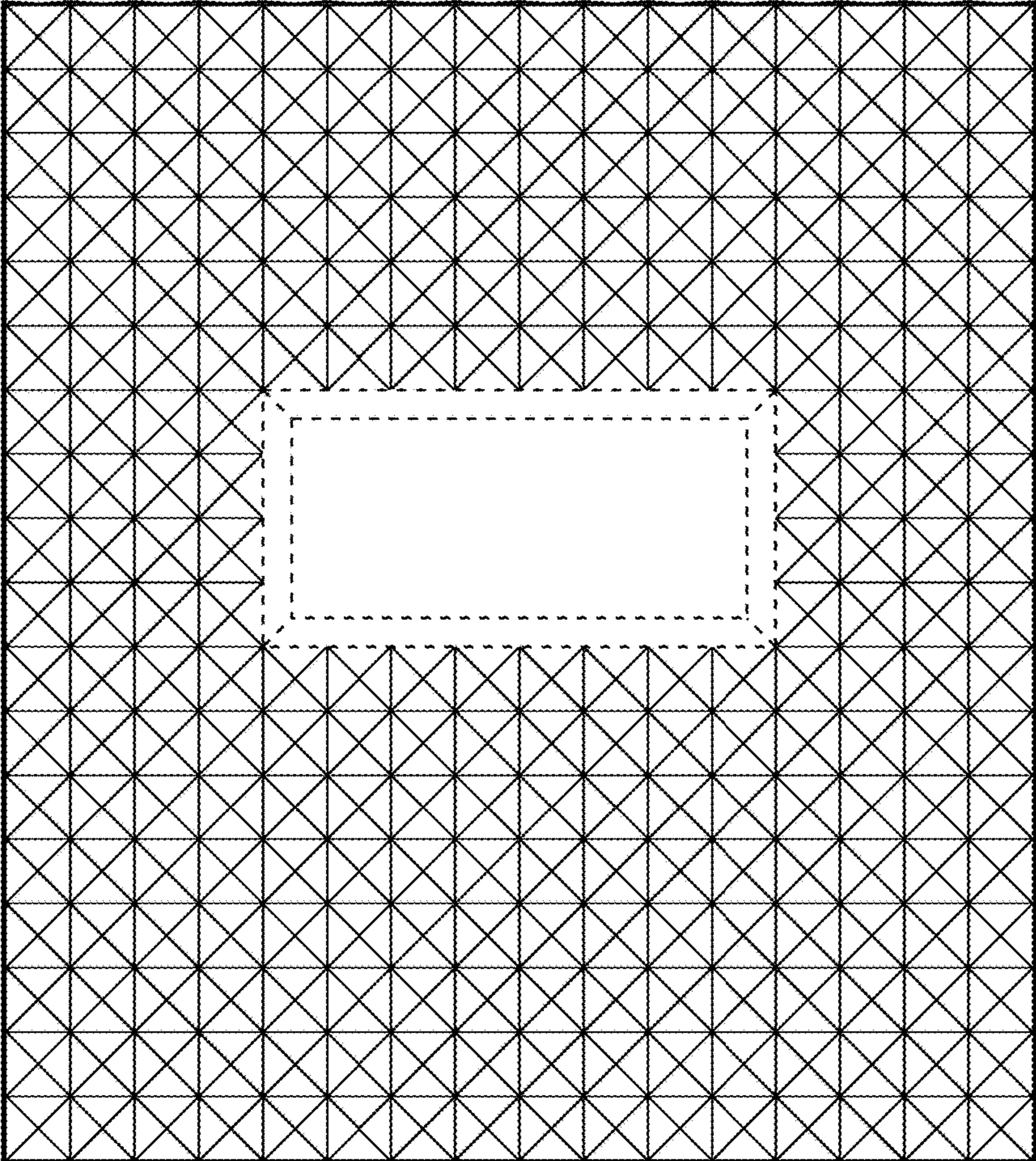

FIG. 2

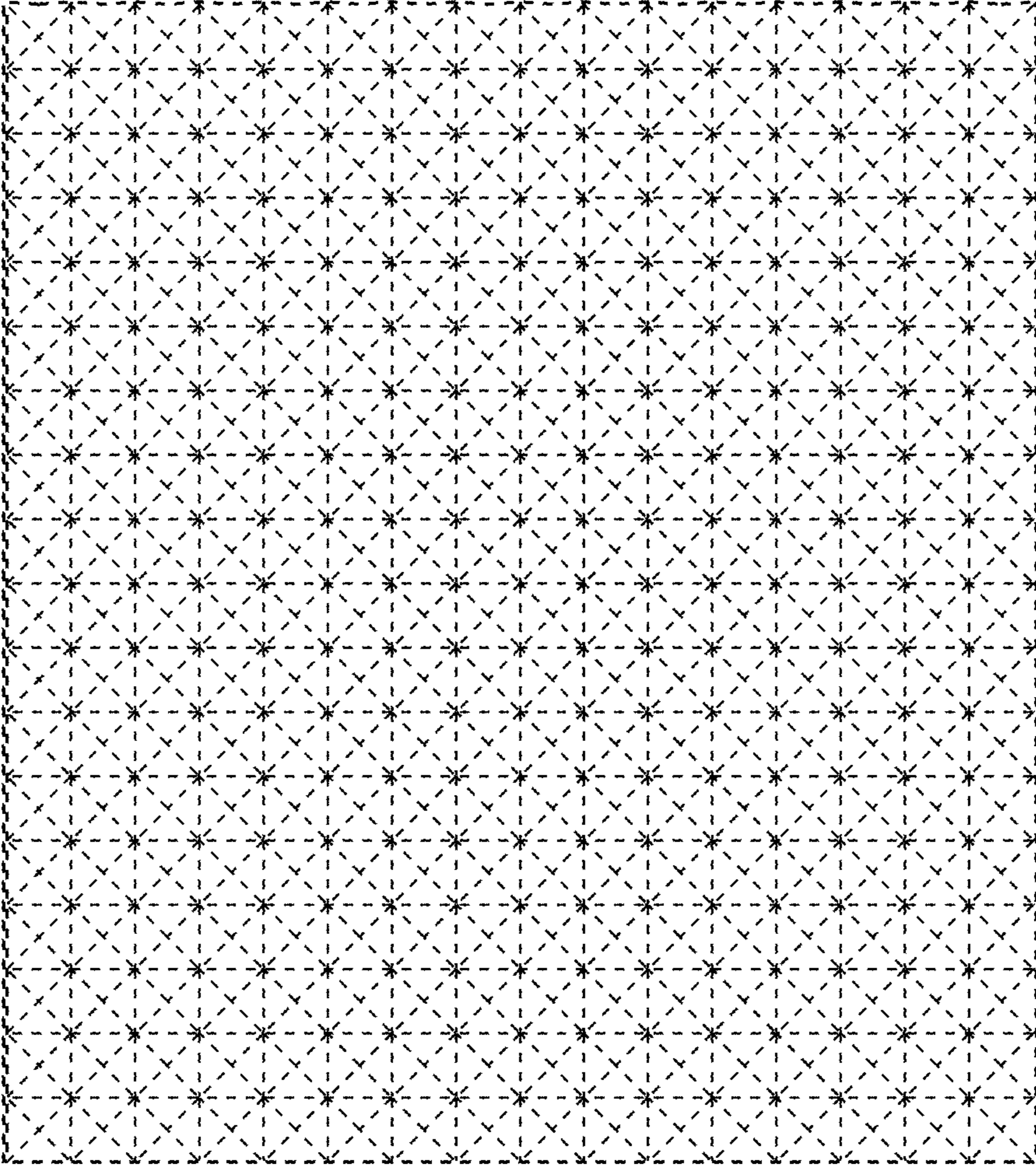

FIG. 3

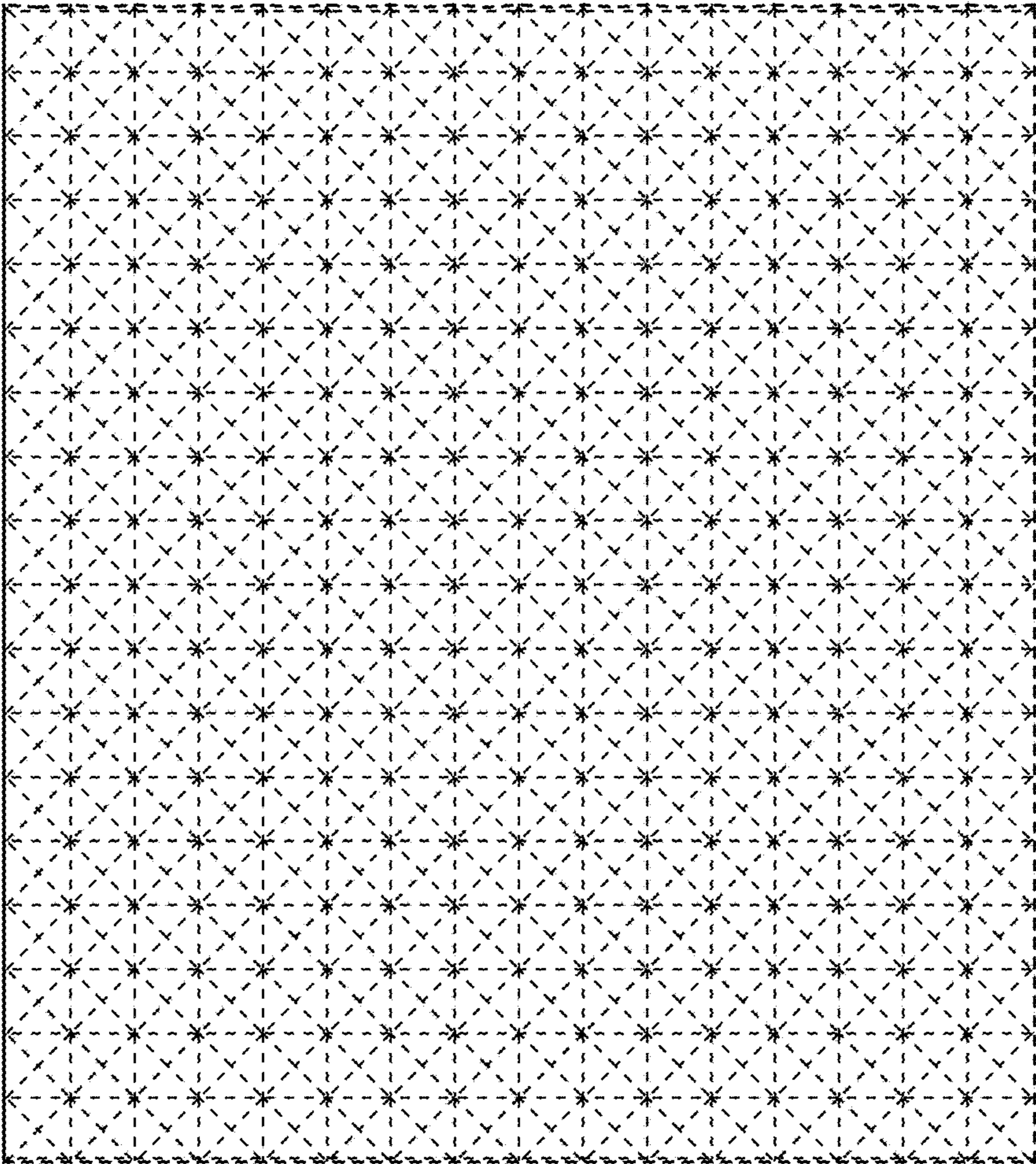

FIG. 4

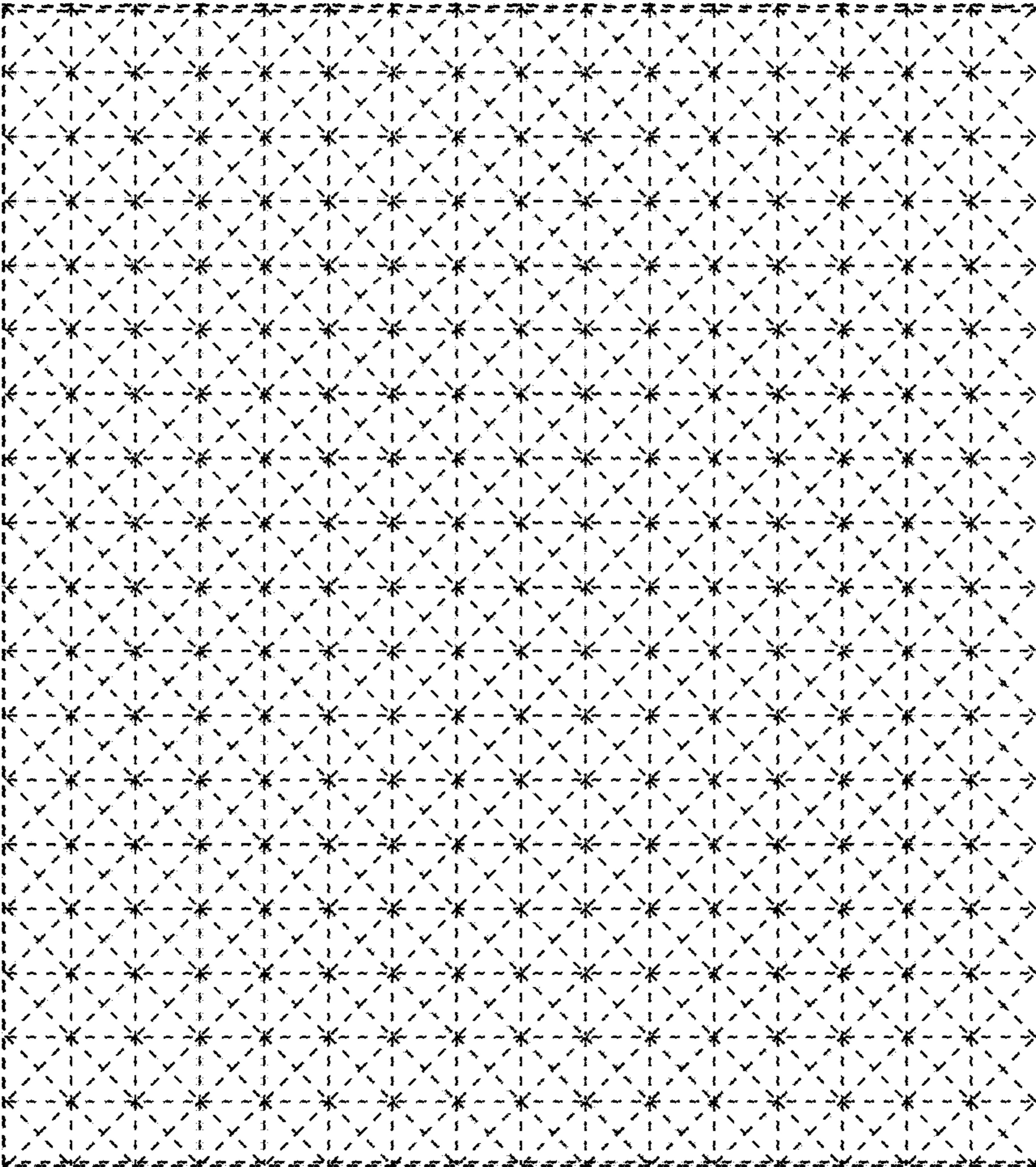

FIG. 5

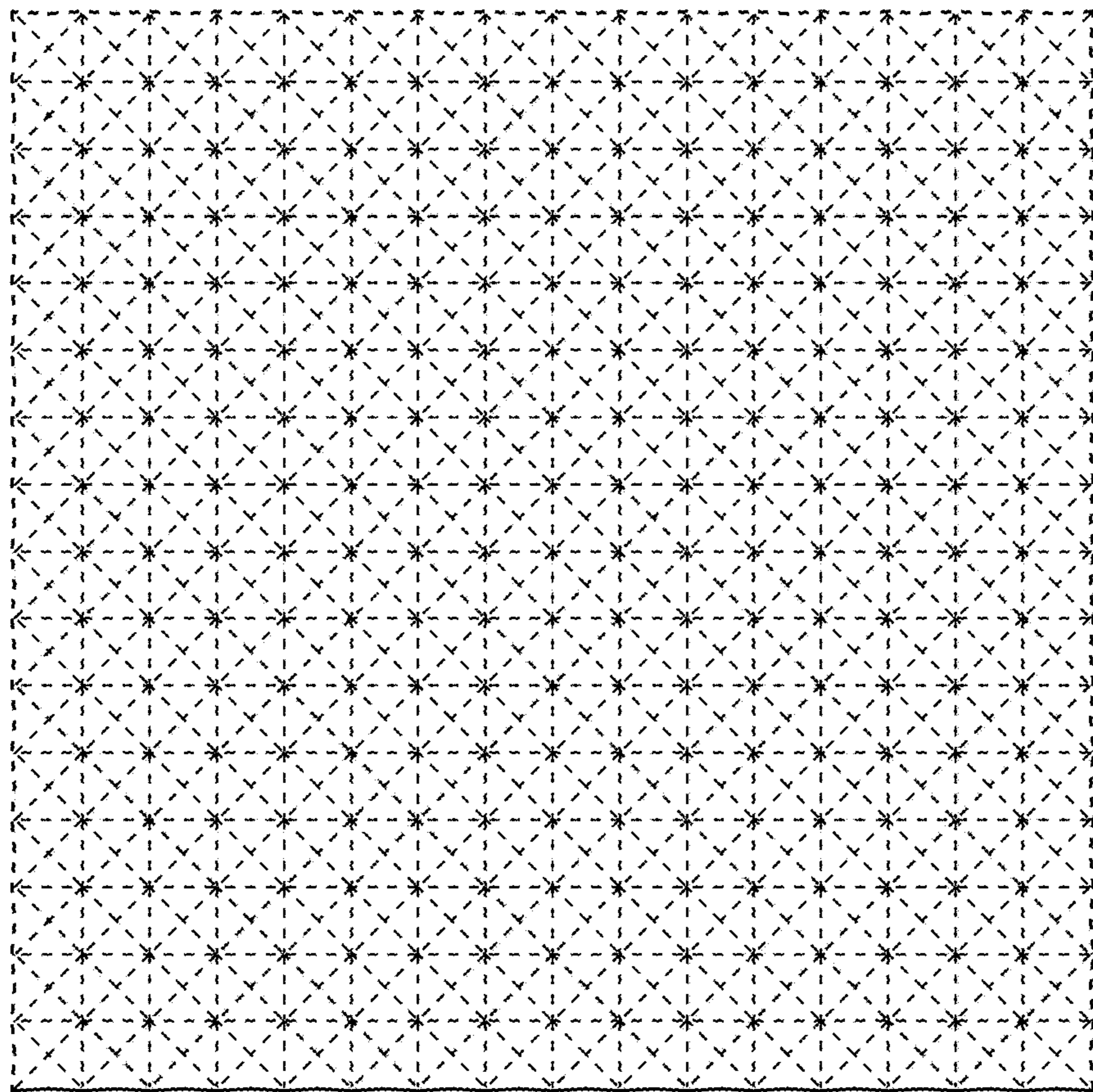

FIG. 6

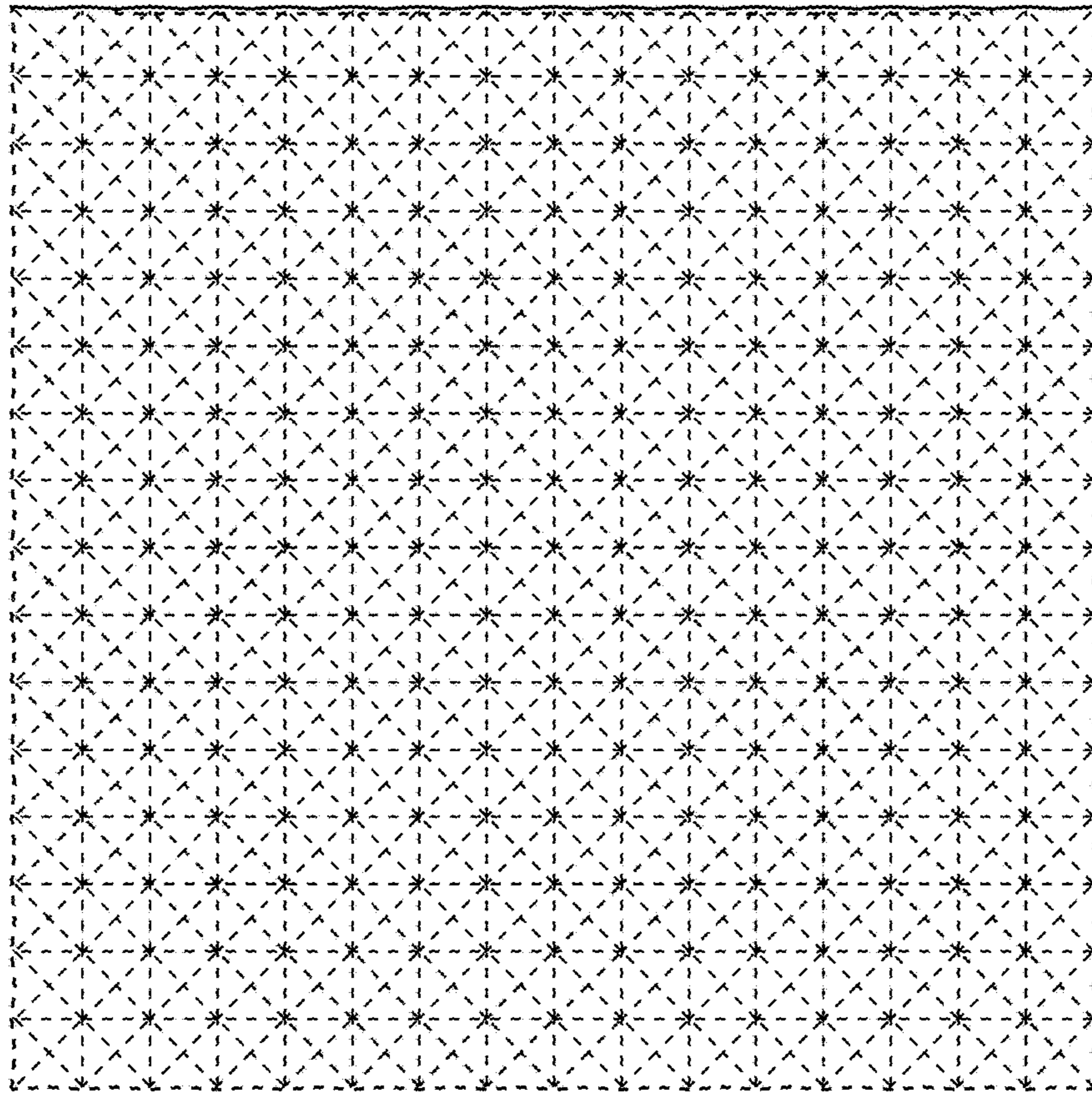

FIG. 7

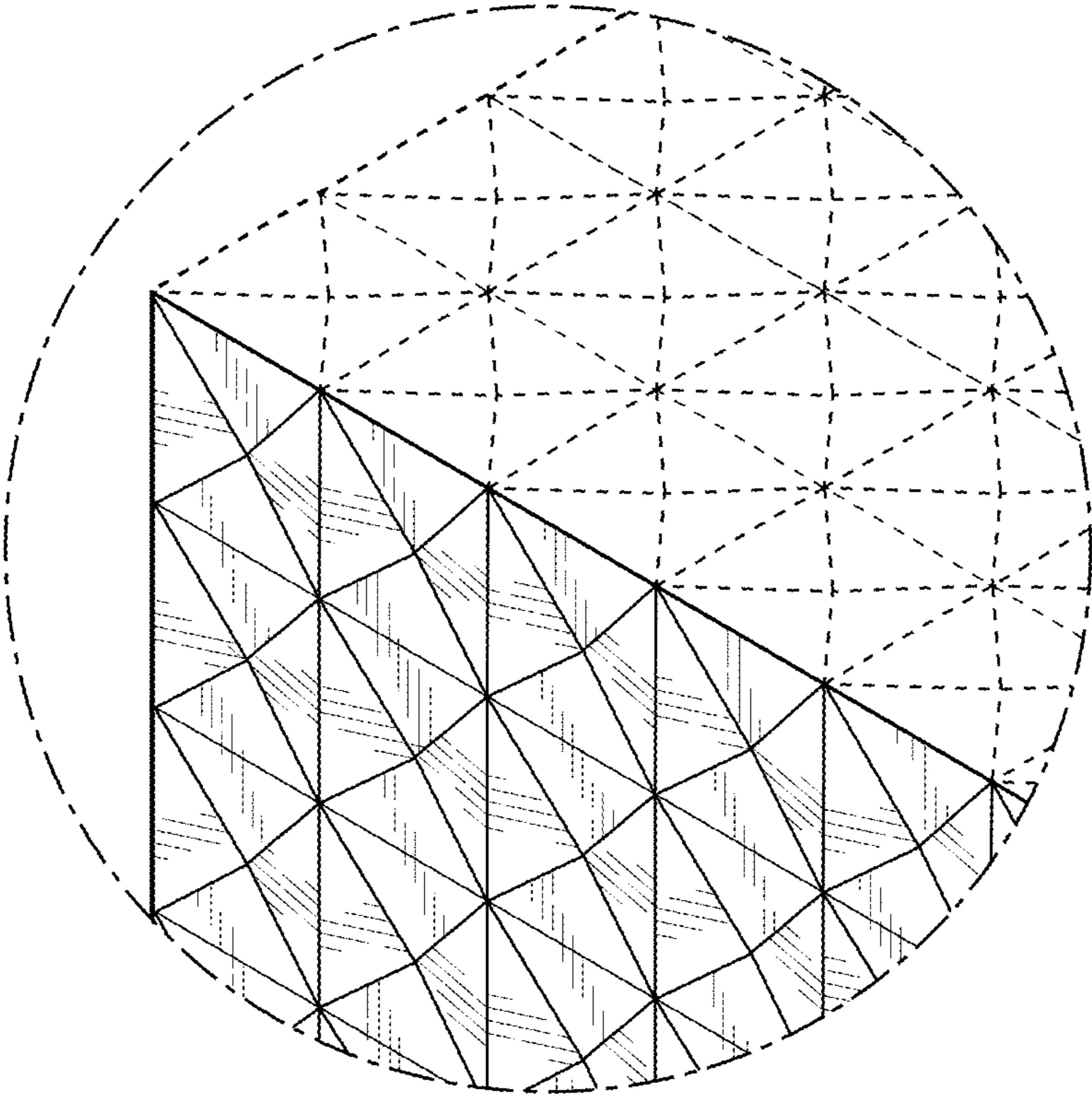

FIG. 8