



US00D782267S

(12) **United States Design Patent**
Jensen

(10) **Patent No.:** **US D782,267 S**

(45) **Date of Patent:** **** Mar. 28, 2017**

(54) **FRAME DIMPLER**

(71) Applicant: **Dale R. Jensen**, Dodge Center, MN
(US)

(72) Inventor: **Dale R. Jensen**, Dodge Center, MN
(US)

(**) Term: **15 Years**

(21) Appl. No.: **29/548,876**

(22) Filed: **Dec. 17, 2015**

(51) **LOC (10) Cl.** **08-05**

(52) **U.S. Cl.**
USPC **D8/73**

(58) **Field of Classification Search**
USPC D8/71-74, 394-399, 59; 248/63, 72,
248/74.1, 689, 124.2; 81/487, 385, 386,
81/388-390; 269/3, 4, 6, 143, 165, 240,
269/243, 246-249, 254 R, 147-149;
29/256, 257, 276; 408/103, 104-109
CPC B25B 1/00; B25B 5/00
See application file for complete search history.

(56) **References Cited**

U.S. PATENT DOCUMENTS

2,432,804	A	12/1947	Rieske	
3,261,073	A	7/1966	Klenk	
3,589,708	A *	6/1971	Cosner	B25B 5/101 269/241
3,997,152	A *	12/1976	Sass	B25B 5/101 269/249
4,707,924	A	11/1987	Burney	
D296,515	S *	7/1988	Cors	D8/59
4,903,929	A *	2/1990	Hoffman	B25B 5/003 24/335
D348,816	S *	7/1994	Degen	D8/73
5,377,415	A	1/1995	Gibson	
D358,538	S *	5/1995	Cote	D8/73
D375,239	S *	11/1996	Hall	D8/73

D398,827	S *	9/1998	Vrilakas	D8/71
D413,429	S *	9/1999	Carson	D3/10
D485,739	S *	1/2004	Carrico	D8/73
D487,689	S *	3/2004	Brass	D8/73
D489,241	S *	5/2004	Parham	D8/73
6,789,791	B2	9/2004	Genduso	
7,610,664	B2 *	11/2009	Wridt	B25B 27/062 269/143
7,743,761	B2	6/2010	Mercord et al.	

(Continued)

OTHER PUBLICATIONS

Small clamp with SS point. Opens to 3/4". Oversized clamp. Opens to 2 1/2". Product Listing [online]. Lind Equipment, 2015 [retrieved on Aug. 5, 2015]. Retrieved from the Internet: <http://www.lindequipment.net/static-bonding-&-grounding-clamps.htm#VnB7e79GRXJ>.

Primary Examiner — David Muller
(74) *Attorney, Agent, or Firm* — Robert C. Montgomery; Montgomery Patent & Design LP.

(57) **CLAIM**

The ornamental design for a frame dimpler, as shown and described.

DESCRIPTION

FIG. 1 is a left side perspective view of a frame dimpler, showing my new design;
FIG. 2 is a front elevation view thereof;
FIG. 3 is a rear elevation view thereof;
FIG. 4 is a top plan view thereof;
FIG. 5 is a bottom plan view thereof; and,
FIG. 6 is a left side elevation view with the right side elevation view being a mirror image thereof.
The broken line showing of parts of the drawings is included for the purpose of illustrating use and environment and forms no part of the claimed design.

1 Claim, 6 Drawing Sheets

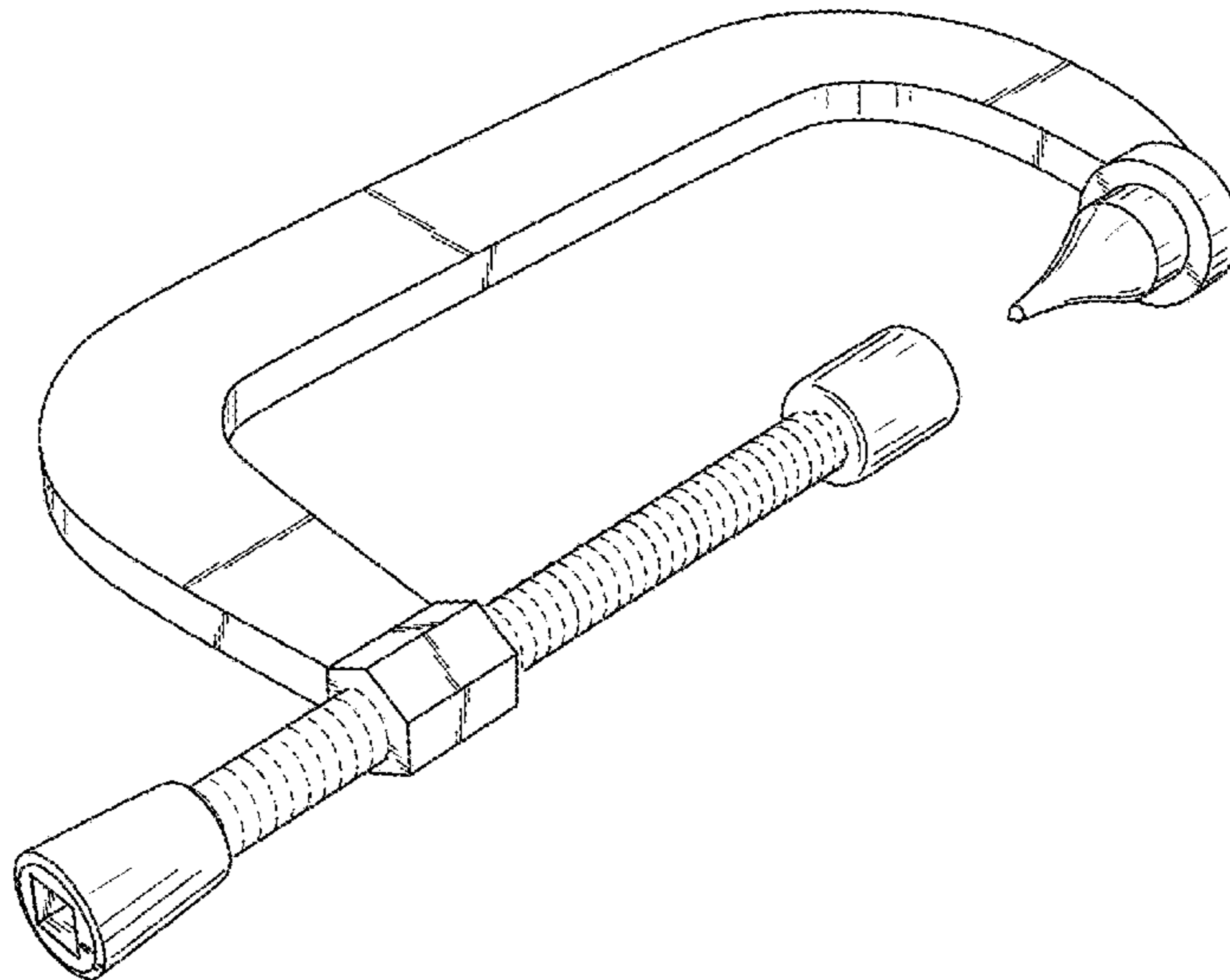

(56)

References Cited

U.S. PATENT DOCUMENTS

2012/0060847 A1 3/2012 Stratton et al.

* cited by examiner

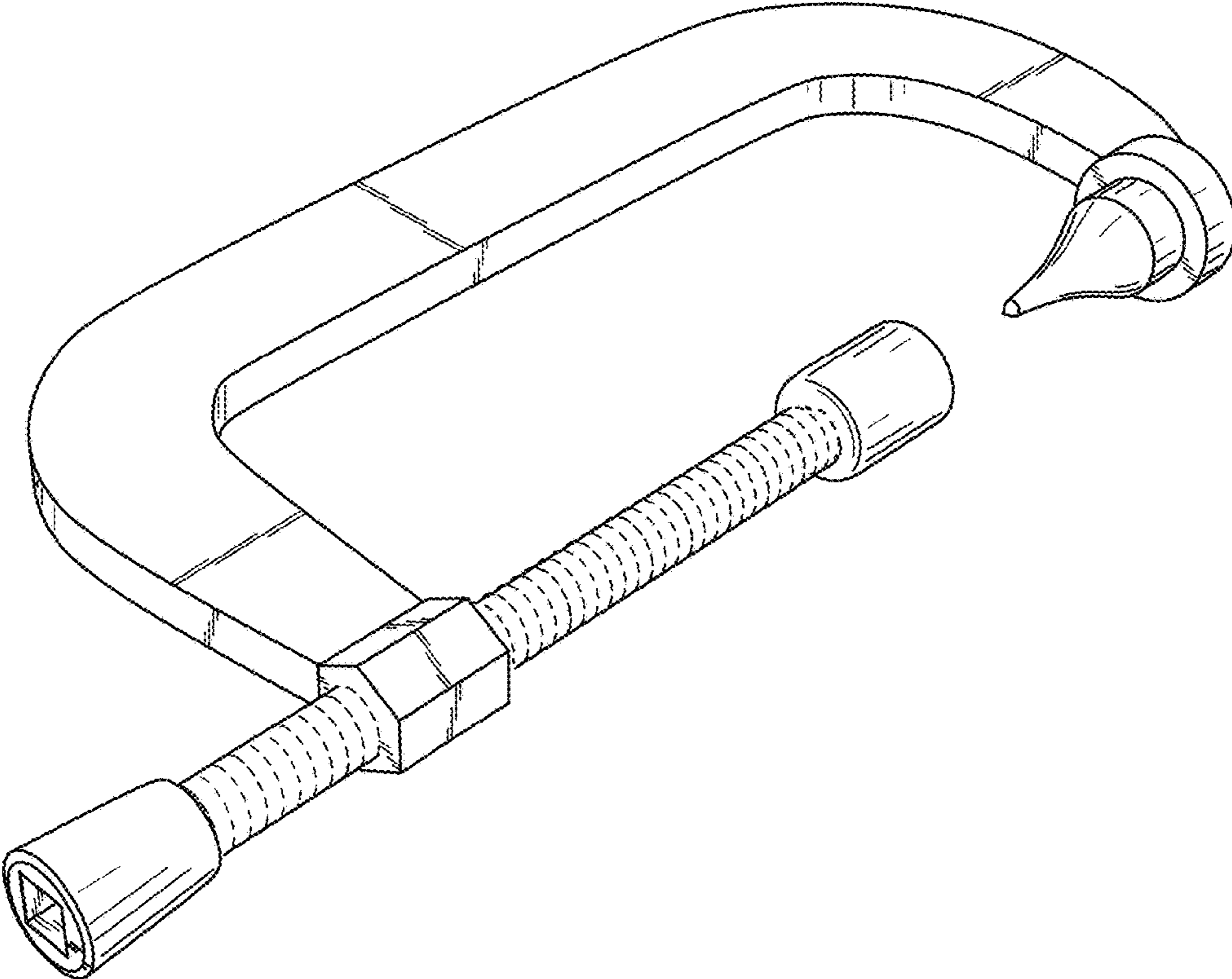

FIG. 1

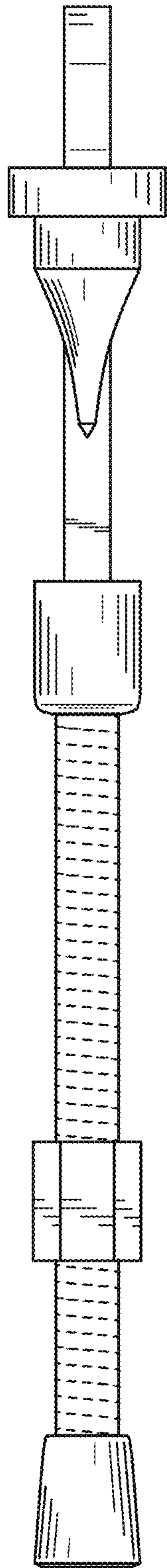

FIG. 2

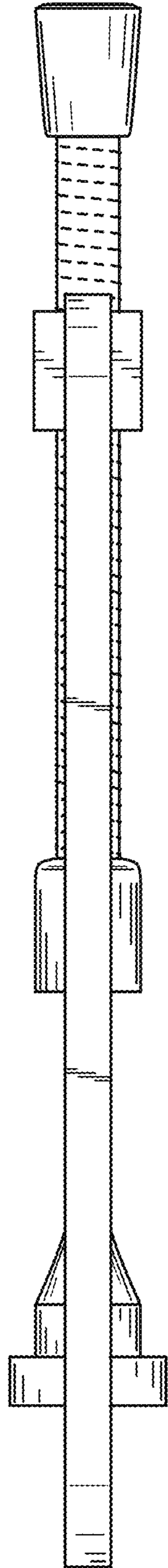

FIG. 3

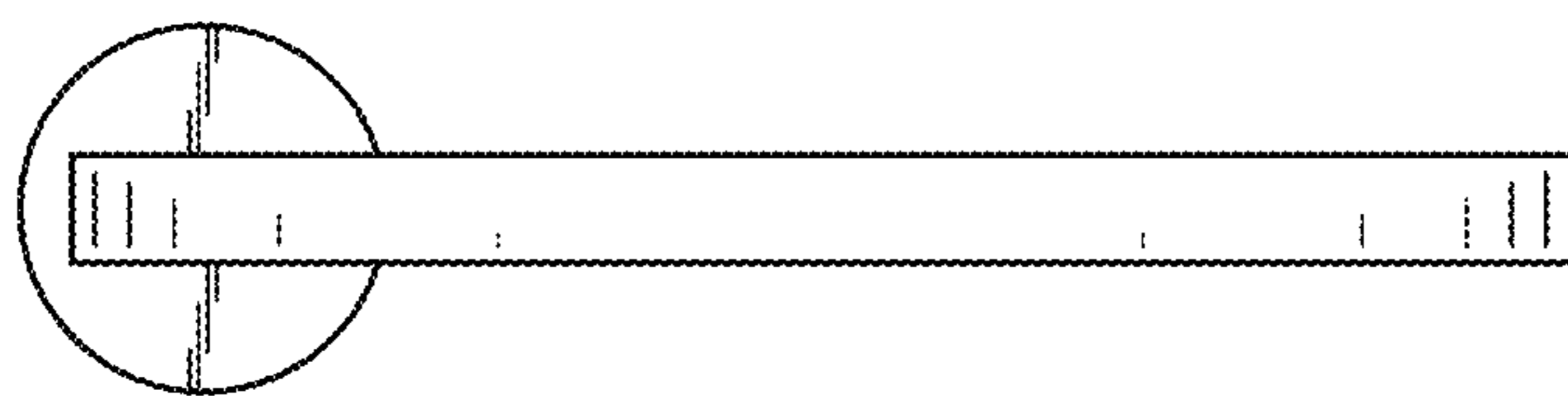

FIG. 4

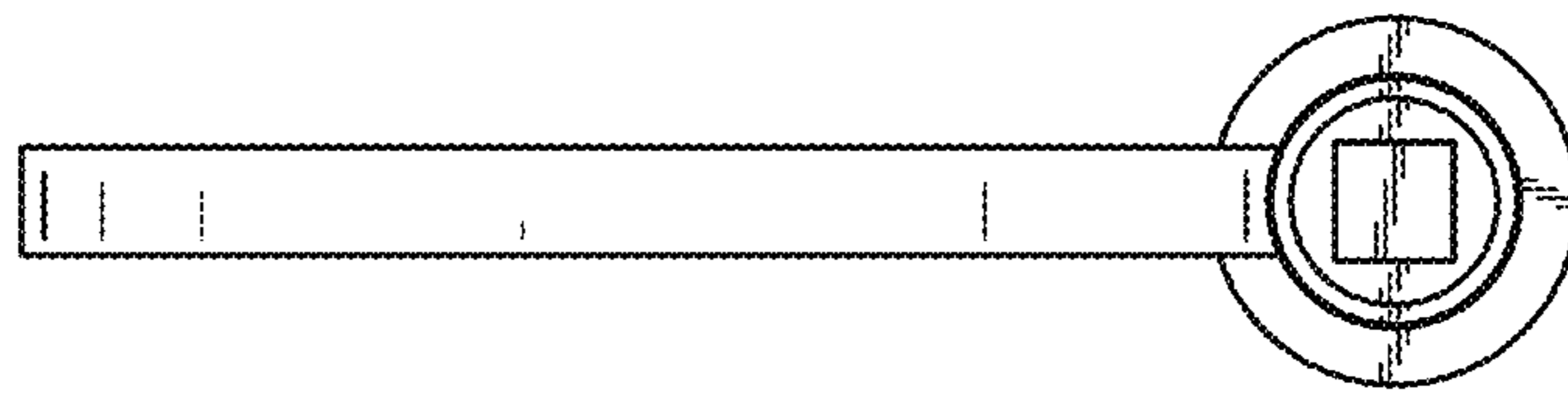

FIG. 5

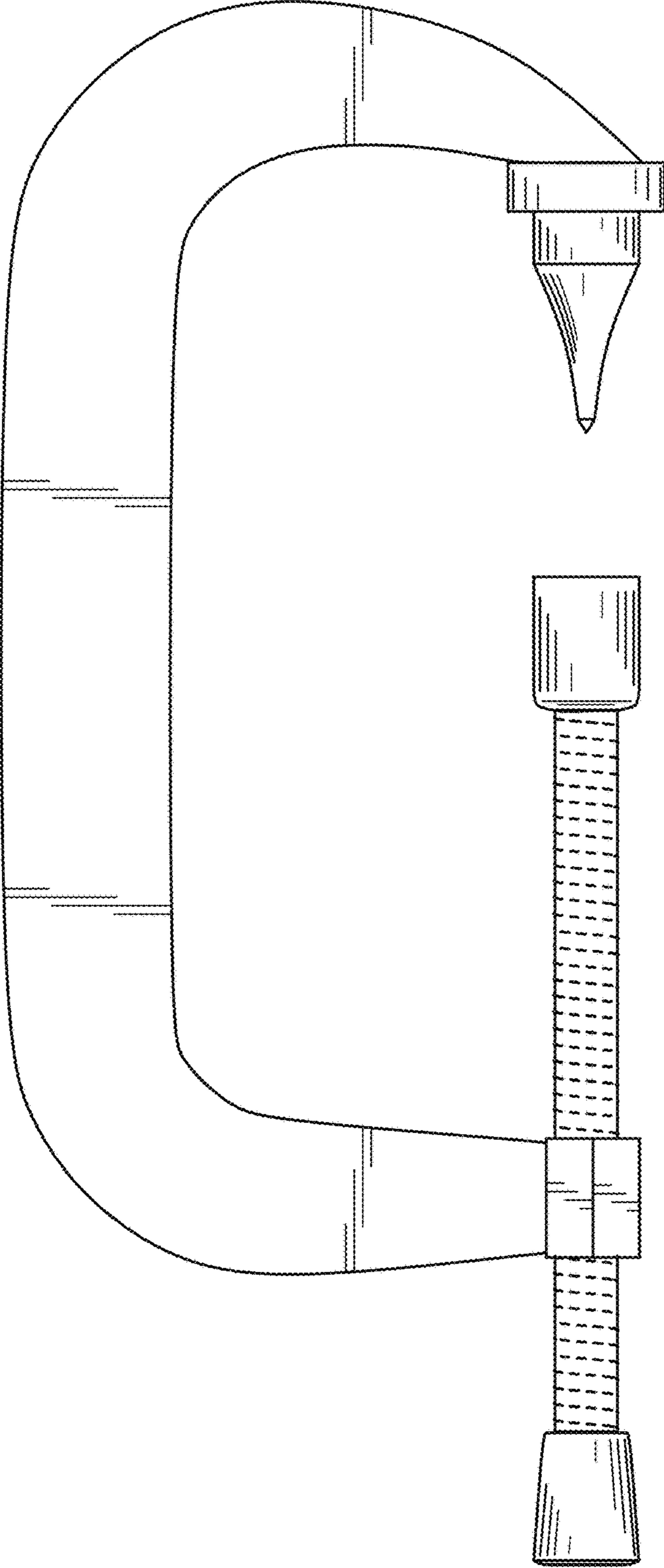

FIG. 6